

“ADDITIONS”

PHASE 2
: for accessibility
: for the structure

PHASE 3
: for a program

AN ADDITION TO GRORUD
Architectural elements of Grorud as generator for a new
wing of the Oslo Schools of Music and Performing Arts

NIKOLAI LIEBLEIN RØSÆG
DIPLOMA
Spring 2020

Institute of Architecture
The Oslo School of Architecture and Design

CONTENTS

2-6	Additions for accessibility
7-10	Additions for the structure
11-20	Additions for a program

ADDITIONS FOR ACCESSIBILITY

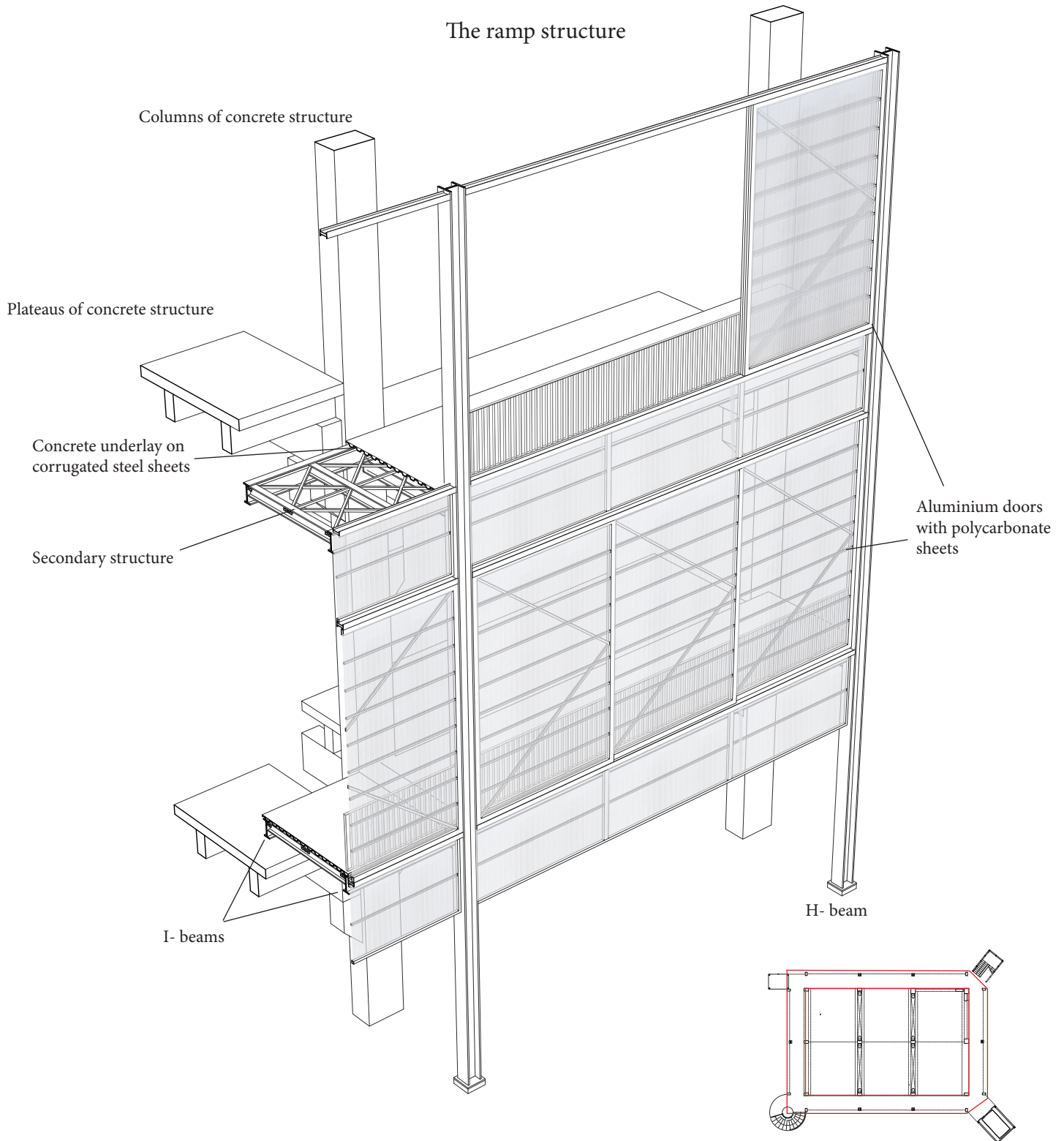

A ramp- and passage structure is added as a new layer for the concrete structure, connecting the plateaus on different levels. It is a steel structure with loadbearing H-columns that support I-beams spanning between them. The H-columns are connected and bolted to the columns of the concrete structure with an I-beam spanning between them. A second I-beam running the length of the ramp is bolted to this same beam. A secondary structure of smaller I-beams and cross-beams span between the large I-beams, supporting

an underlay of concrete fastened and casted in corrugated steel sheets. An additional structure of sliding doors in aluminium inserted with the thermoplastic polycarbonate plates, gives an insulating effect and another quality of transparency. The polycarbonate protects the concrete structure from weather and gives comfortable conditions on the ramps. The ramps have a depth of 2,4 m, making them accessible for both passing and shorter stays.

ADDITIONS FOR ACCESSIBILITY

The spiral staircase

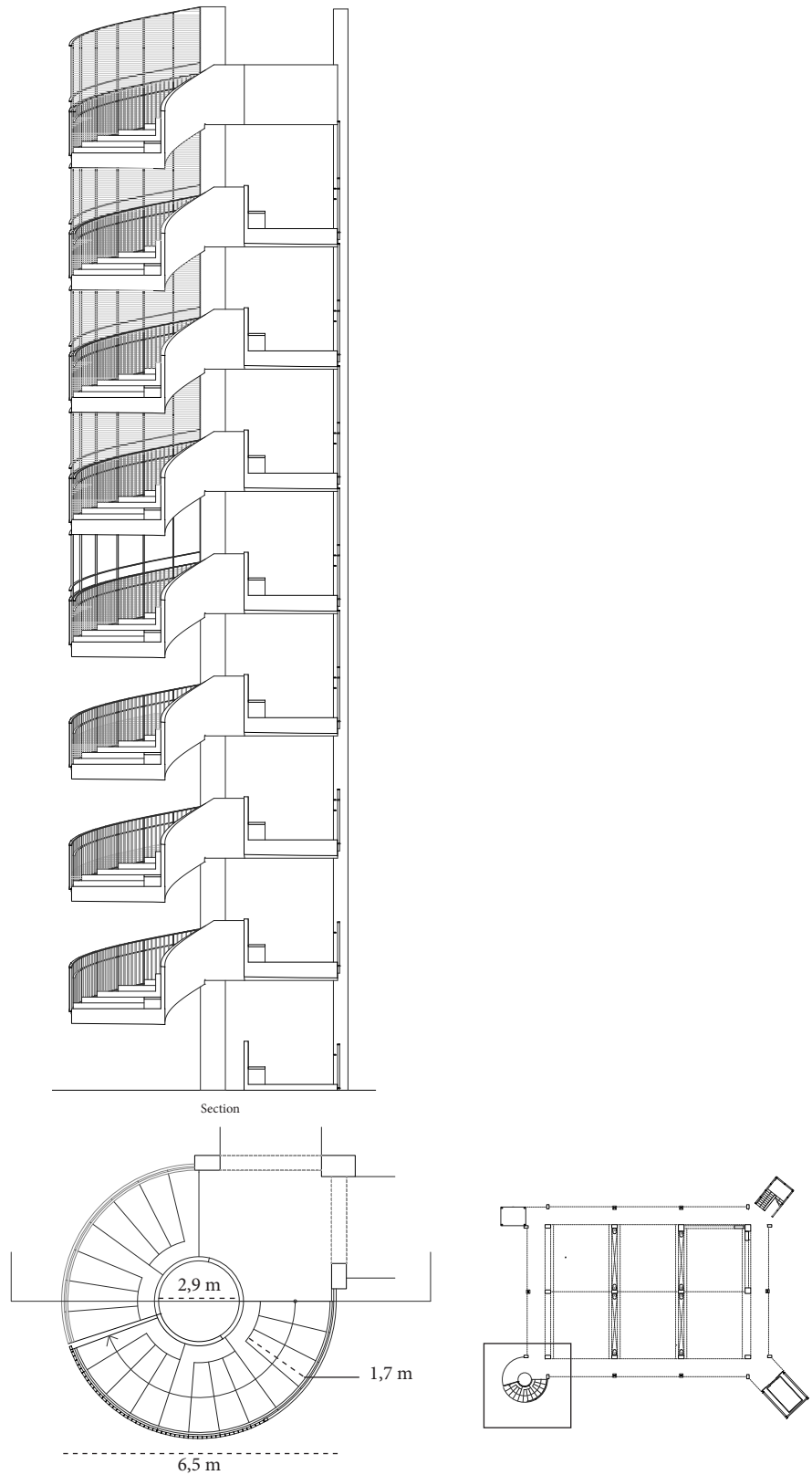

The concrete spiral staircase stands in open air in the south-west corner of the structure. The rail changes for safety as the stairs climb. As the rail becomes higher, a mesh climbs with it, distinctly making a clear framing with the mesh running the whole height of the stairway. It is a wide staircase with 1,7 m

passageway with additional 40 cm sitting plateaus along the inner solid rail. This makes the staircase a possible place for stay as well as passing. Movement, sound, and voices from the staircase can be seen and heard from the public ground below and the surroundings.

ADDITIONS FOR ACCESSIBILITY

The glass block elevator

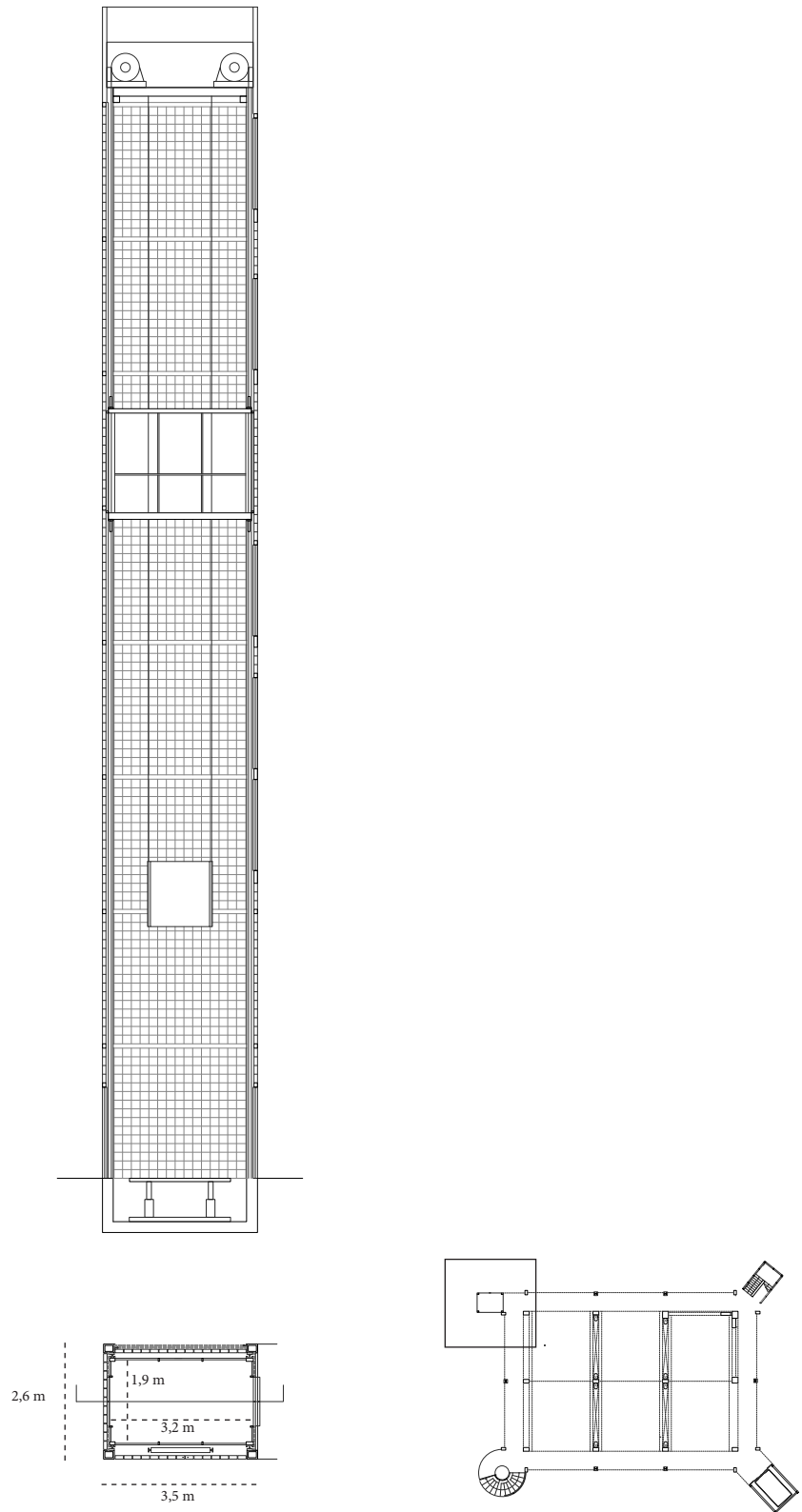

The elevator stretches as a translucent unit in the north-west corner of the concrete structure. It is constructed by hollow steel columns with inserted glass building blocks running all the height of the elevator shaft. In play with the elevator car in glass, the

outlines of people traveling between floors can be seen on the outside, while a travel in light can be experienced inside. At night the shaft is lighted from the inside, making the elevator present as a beam of light for the surroundings.

ADDITIONS FOR ACCESSIBILITY

The steel elevator

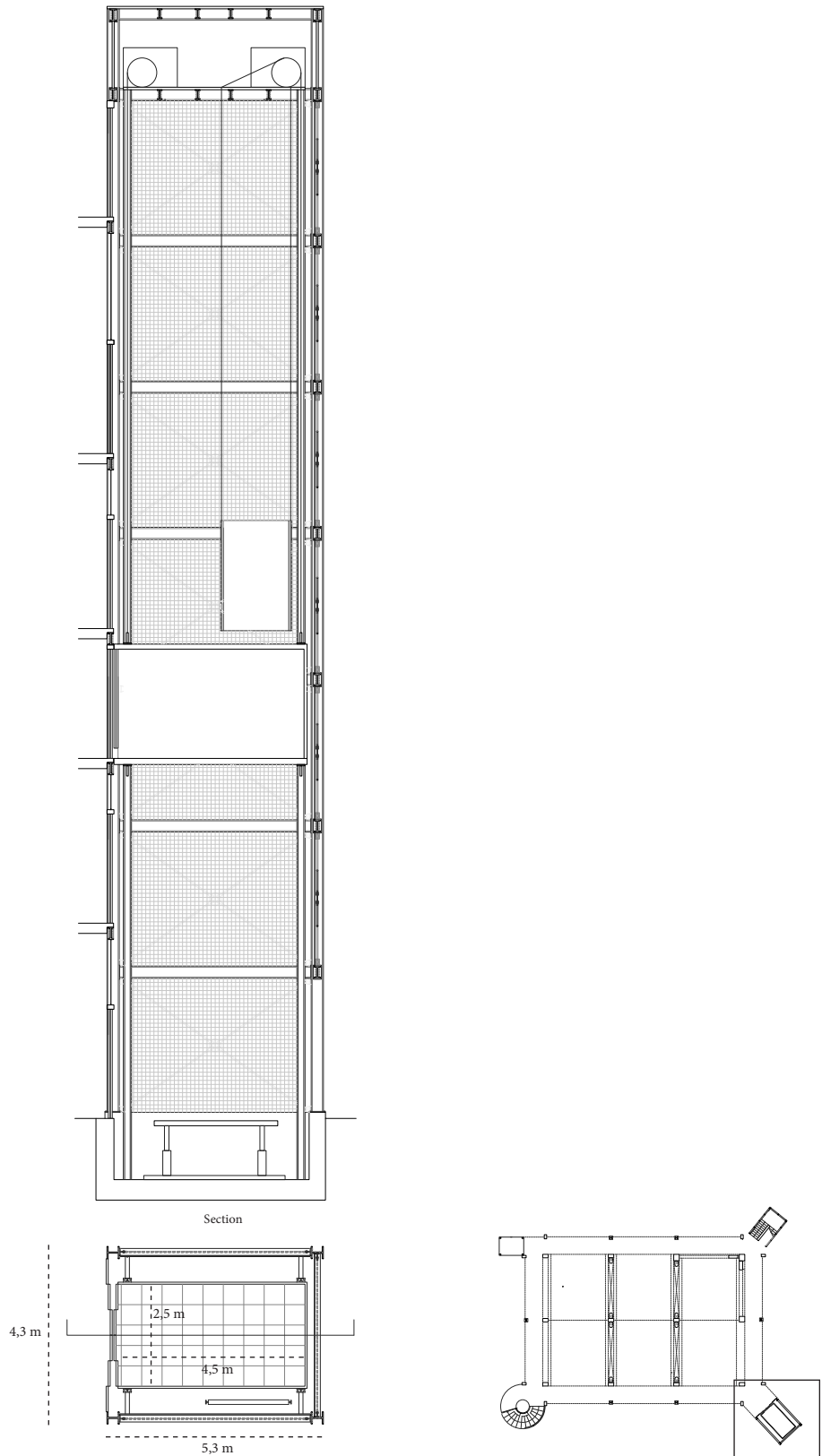

A robust steel construction supports a large elevator in the south-east corner of the building. H-columns in the four corners, connected by I-beams spanning between them, cross stiffeners in each section, and a steel grid mesh, support the high elevator shaft and the large car inside. The dimensions of the interior

space of the elevator car make it suitable for carrying goods as well as people. Its size makes it fun to travel with for the pupils. The exterior of the car is painted a clear red. This will make it a visible unit of vertical movement in play with the red buses that seep in and out of the bus station in front.

ADDITIONS FOR ACCESSIBILITY

The lamella staircase

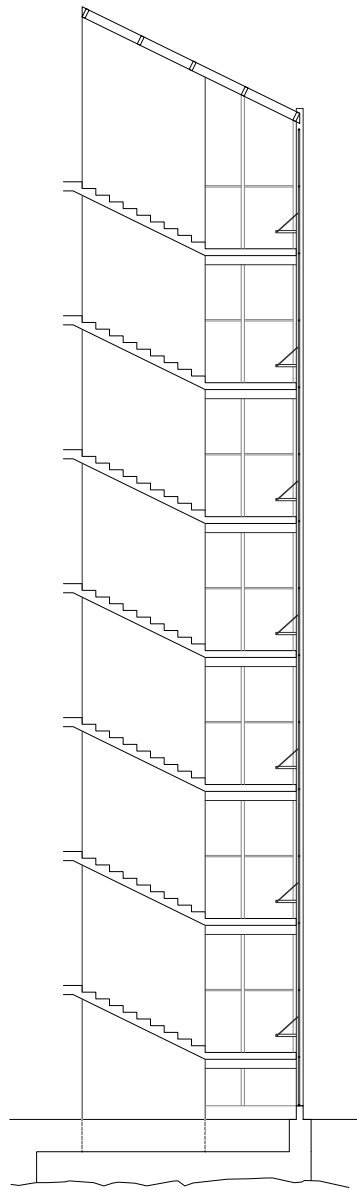

Section

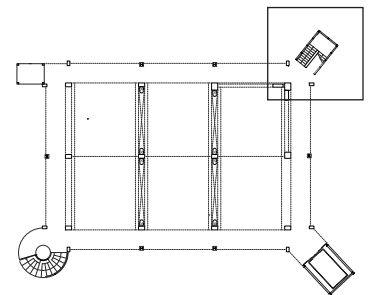
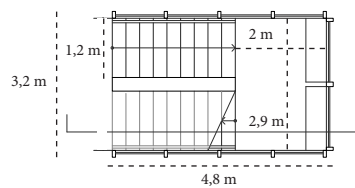

In the north-east corner of the concrete structure raises a tower of stairs supported by a distinct concrete lamella. The stairway is framed by a slender steel construction carrying translucent glass. At each half-level the glass at eye-level is transparent.

From here one can look into the treetops the further up one gets, as well as the distant surroundings. A bench for every half-level makes it possible to rest and stay in the stairway.

ADDITIONS TO THE STRUCTURE

Diagonal beams

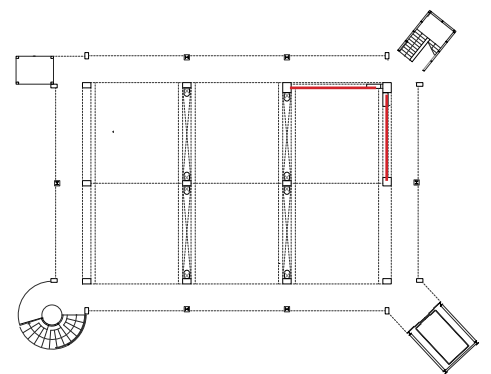
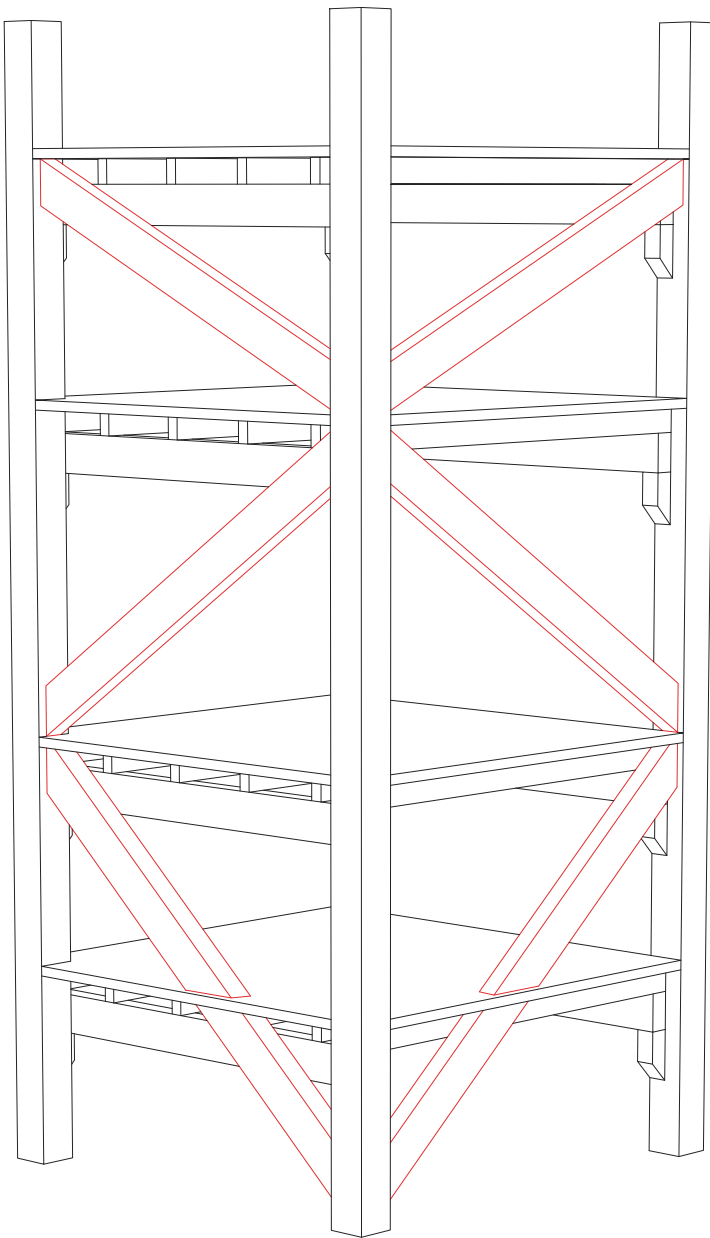

Diagonal stiffeners of concrete beams are added all along the structure's north-eastern corner to support the structure. The thickness of the three columns they are connected to are increased to cope with pressure and prevent buckling.

ADDITIONS TO THE STRUCTURE

A passage for technical installations

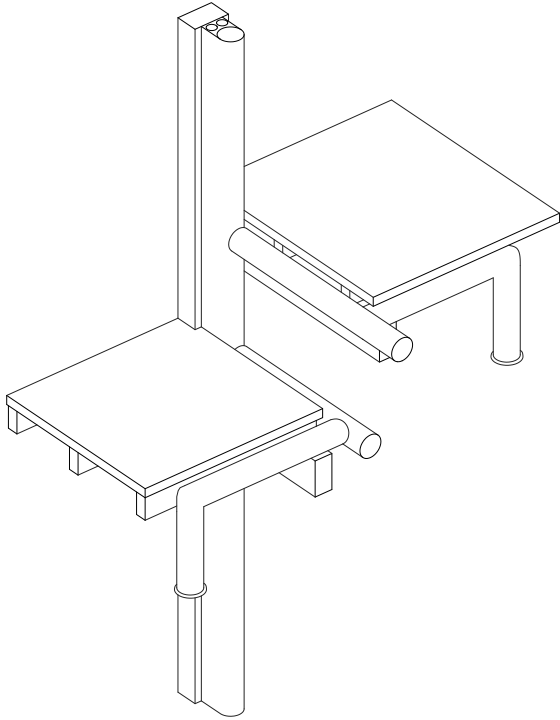

Along the columns in the structure's shafts between levels, an arrangement for leading ventilation, water and electricity is installed. The technical canal-unit is given a pronounced red colour to mark its presence.

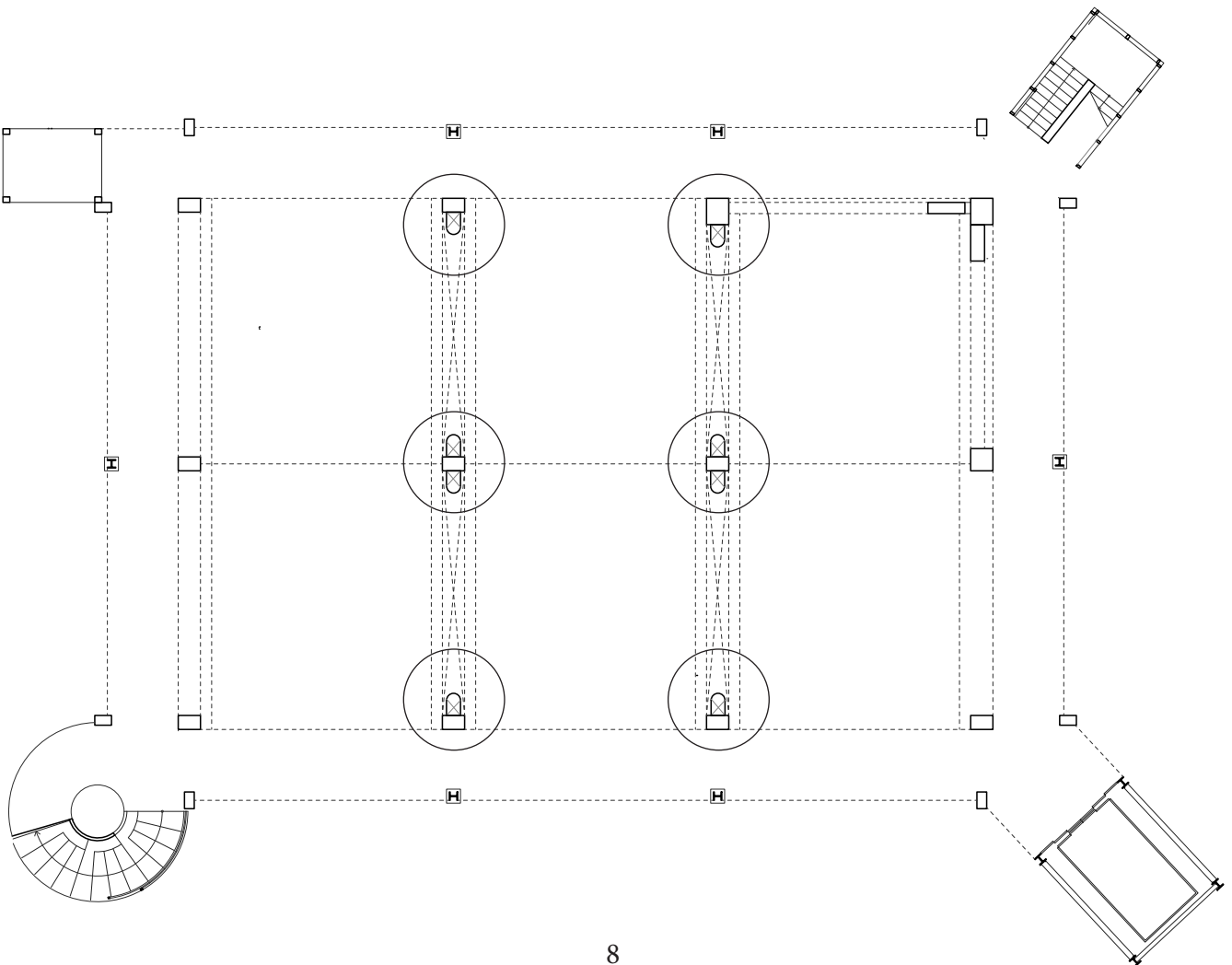

ADDITIONS TO THE STRUCTURE

The insulating windows

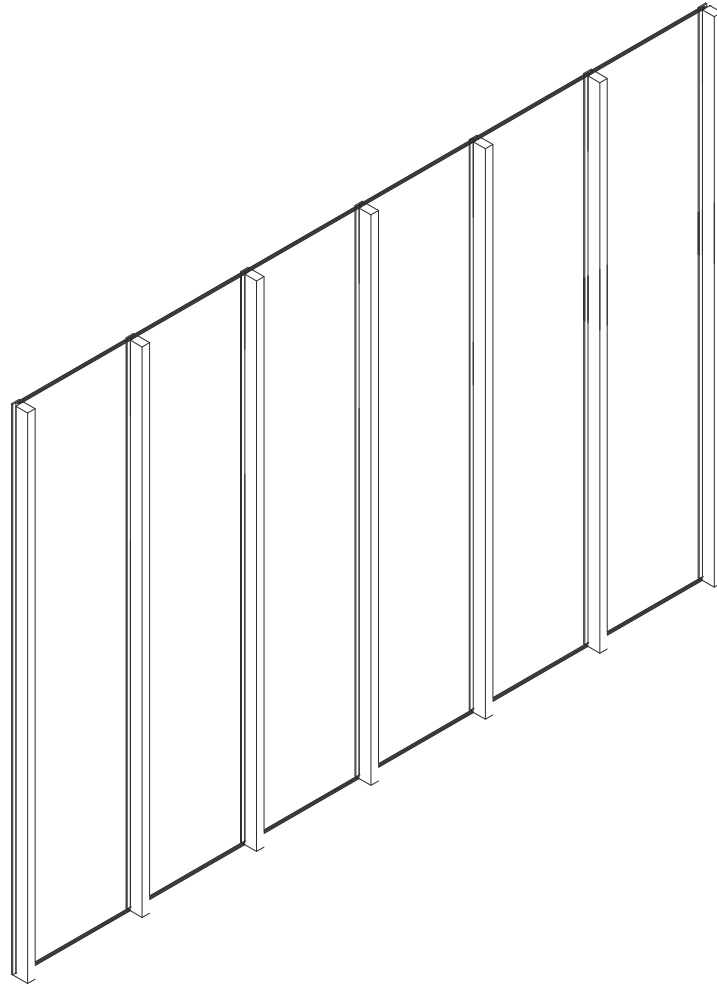

Triple pane glass with an extra insulating effect is inserted in aluminium profiles fastened to and supported by glue laminated oak studs. It makes a window wall providing the interior spaces with an amount of natural light, as well as providing for visual contact between the levels and the outside. The glue laminated oak studs turning in to the interior space distinctly subdivides the perimeter of the space and its materiality gives a warm feeling. The slabs of the concrete structure is insulated locally where it passes through the thermal envelope to counter the effect of thermal bridging into the interior.* The columns are insulated with an outer layer of 5 cm polysterene boards with a concrete cladding.

* Reference/source for insulation principle: School in Grono, Rafael Zuber

ADDITIONS TO THE STRUCTURE

The lattice beam roof structure

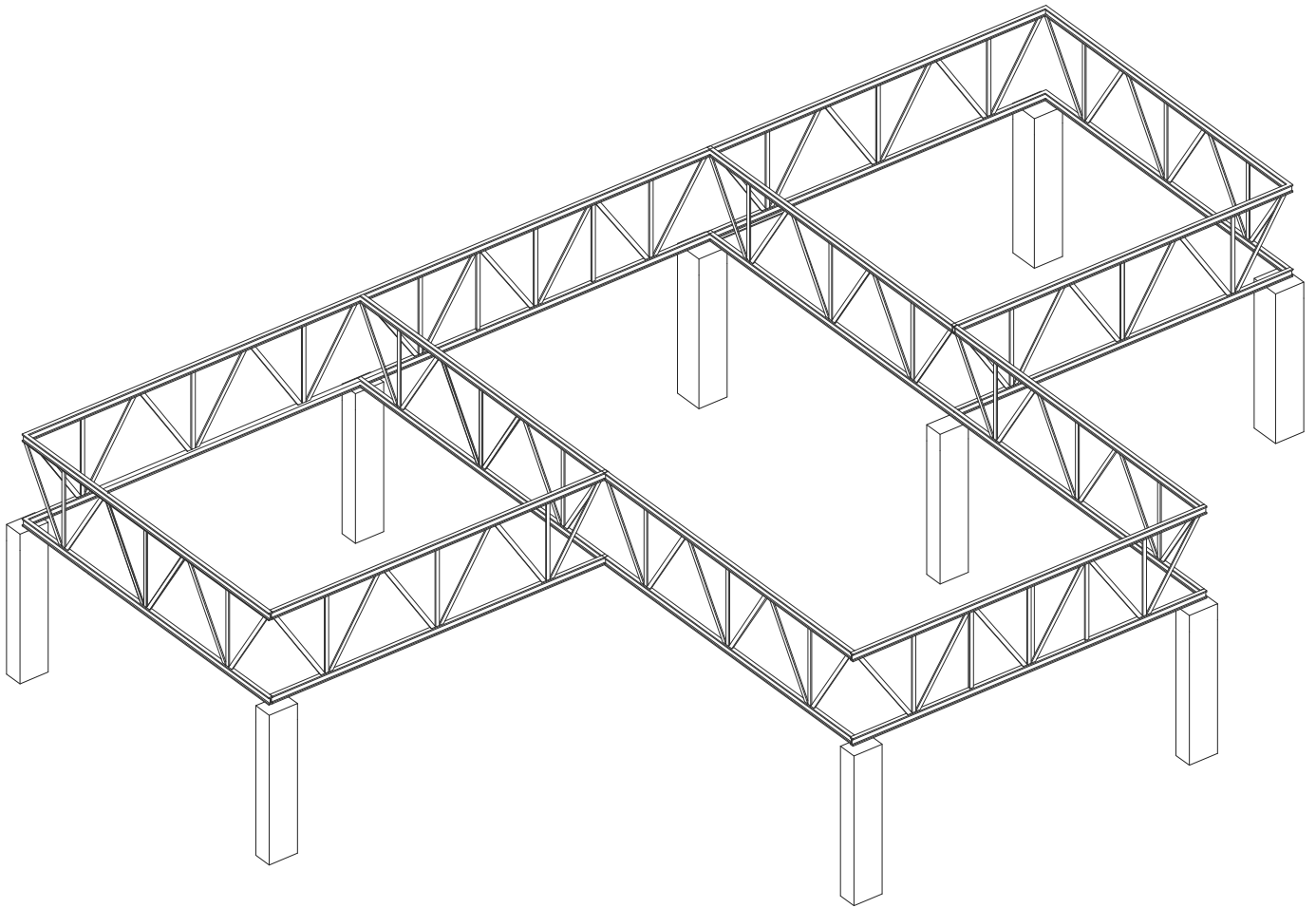

A lattice beam structure in steel is added on top of the columns, as a support structure to carry the roof. The lattice beams make a pronounced ending for the structure, with its own character.

ADDITIONS FOR A PROGRAM

The new layers of floors

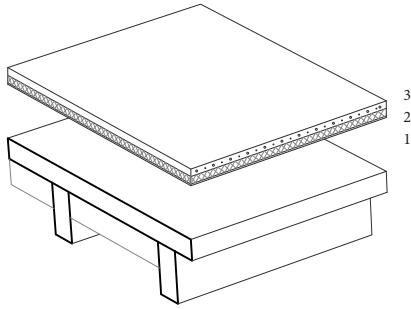

Floors for common spaces and classrooms for visual art

A sanded and treated concrete floor is suitable for rough activity, wear and tear.

- 1 Plates of acoustic underlay
- 2 5 cm pressure-resistant insulation
- 3 5 cm reinforced concrete with heating cables

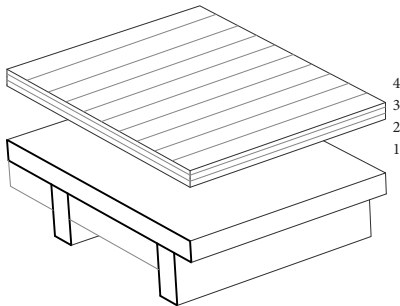

Floors for physical activity

A hardwood floor of oak laid on synthetic elastic layers gives flooring with give-away-effect. This reduces the risks of wear and damage for the people using it. The wooden surface gives a warm feeling.

- 1 Damp proof membrane
- 2 Cellular polyurethane
- 3 Semi-flexible suspension panels
- 4 Hardwood parquet in oak

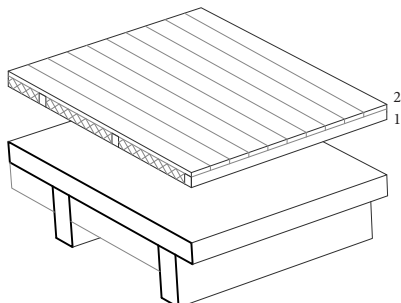

Floors for auditorium

A thick wooden flooring on laths gives a robust floor that is suitable for wear and tear by equipments and installations being moved in and out, as well as the activity of people. It can be layered with mats for an extra protective layer for physical activity. Its thickness also makes it possible to fasten things to the floor.

- 1 Wooden laths with pressure-resistant insulation
- 2 Hardwood in oak

ADDITIONS FOR A PROGRAM

The chairs and folding tables

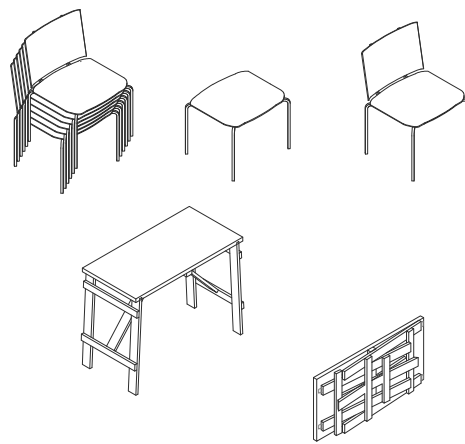

The chairs and tables are given an extra sense of flexibility by their materiality and function. The chairs consist of carbon steel pipes and treated plywood, easy to move around and stack. The folding tables in treated pine have a length of 1 m and a width of 50 cm, with an easy flip-and-fasten solution, making them manageable for both young kids and adults. As folded, the tables can easily be stacked up against each other in corners and behind units in the school. The furniture can be moved around the school and be used both inside and outside. Multiple tables can make a variation of settings for activity which need a certain work space, gathering a lot of people, or more intimate situations.

ADDITIONS FOR A PROGRAM

The toilet units

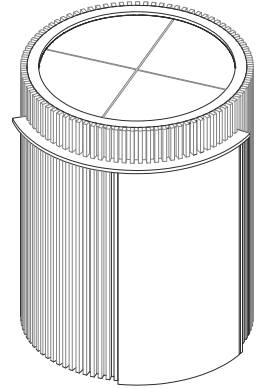
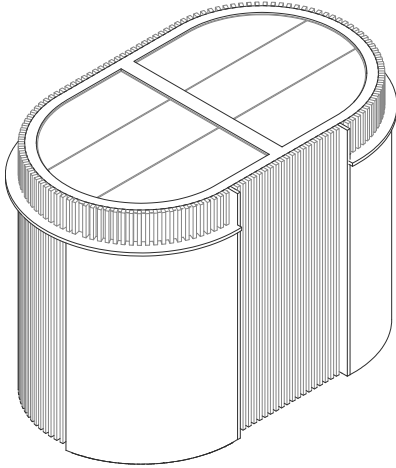

The toilet unit makes it possible to not subdivide a plateau to provide for necessary facilities. As a freestanding unit it becomes an own participant in the space with its own character. The units are situated in corners where they can be connected to the technical guides along the columns, with a gap between the unit and the glass wall making it possible to store things behind it. It is made out of a studwork and plates, with waterproofing layers. Its exterior surface consists of oak balusters that can improve the acoustic surroundings of the space. The interior of the unit is mainly tiles of red and blue colour. The units are proportioned for functionality, and make out a single toilet unit, toilet of universal design, a two-space unit for a toilet and a shower, and a divided changing room unit. Each unit has a transparent glass roof to let natural light in.

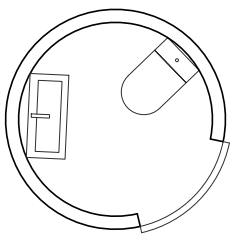
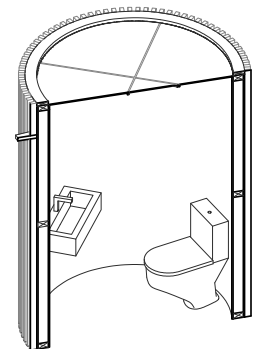
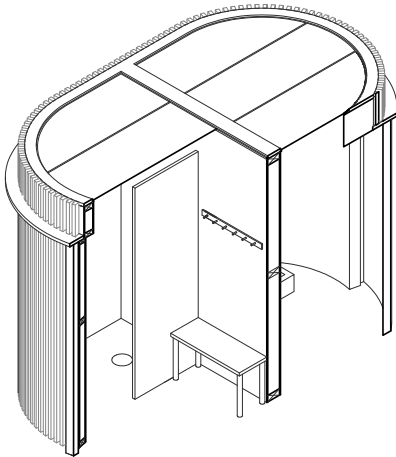

Single toilet

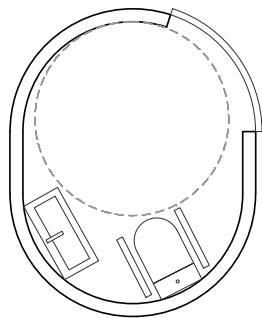

Universally designed toilet

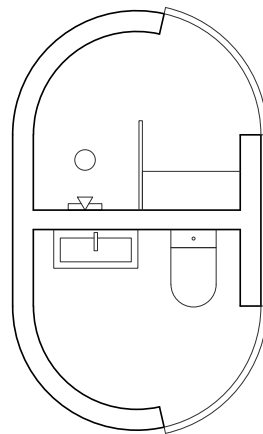

Toilet and shower unit

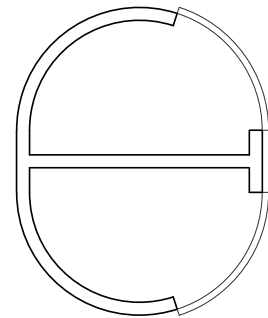

Changing room unit

ADDITIONS FOR A PROGRAM

Common use furniture

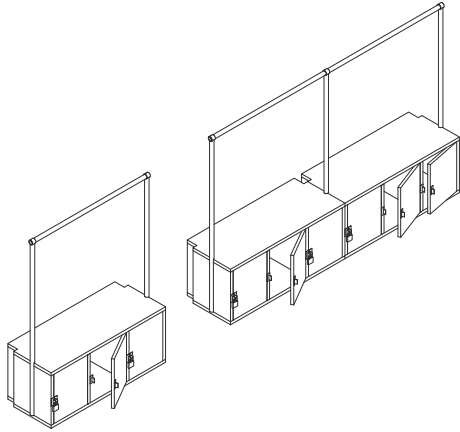

The lockers

The lockers of plywood are made as a single unit with three lockers and a rail for hanging clothes. The units can be combined as required. They are placed around in different levels in the building, both in common spaces and in classrooms, as a necessity to how one moves around in this building. It ensures that pupils and staff can have their personal belongings in a specific place near where they stay.

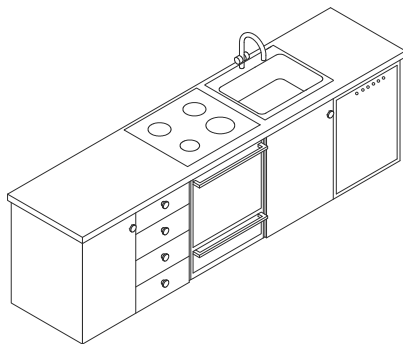

The kitchen

A small kitchen is added to common spaces for pupils and staff. It provides daily for small cooking before or in between classes, as well as for preparing food for events. Pupils who are comfortable in a kitchen and come to classes directly after school can cook for themselves or gather for a joint meal. The kitchens are situated in corners connected to the technical guides along the columns.

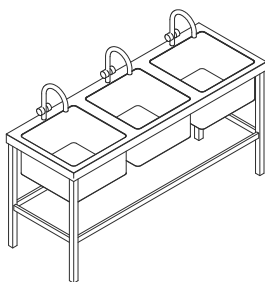

The steel sinks

The steel sinks are situated at every plateau where messy activity can occur. It provides for easy and robust facilities to clean tools, for use in production, for incidental injuries, and for cleaning the spaces. The sinks are situated in corners connected to the technical guides along the columns.

ADDITIONS FOR A PROGRAM

Facilities for a classroom for dance

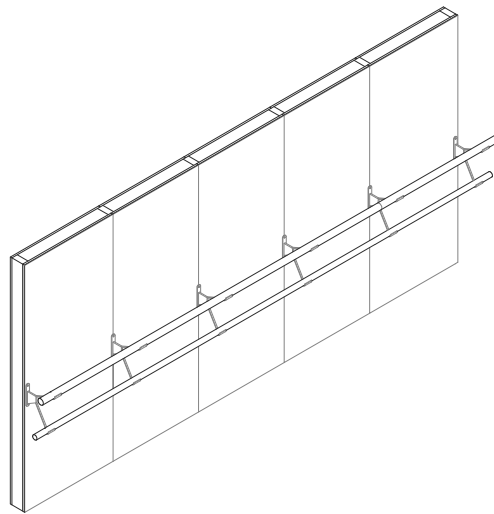

2 m high running mirrors and a dance barre are added to the classrooms for dance to provide for technical training and improve the pedagogic learning conditions. The mirrors and dance barre are in need of a supporting wall. These walls are added to the structure with a height of 2 m. The wall extends as a glass wall, to continue the flow of light in to the building.

ADDITIONS FOR A PROGRAM

The auditorium

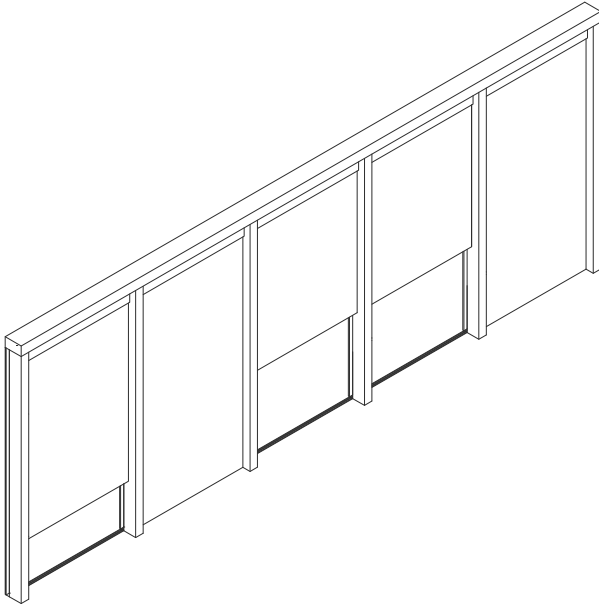

Blinders

Blinders of black textile are fastened between the studs of the windows. They can be used to darken the space, creating the atmosphere of certain performances and for use of stage lighting.

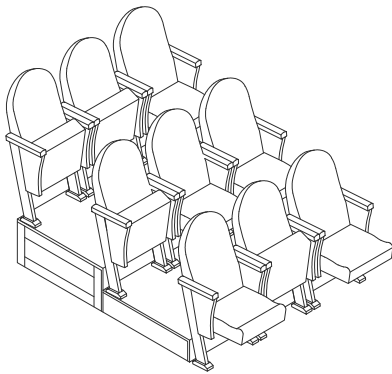

Amfi

An amphi is built up from the concrete plateau with a stud construction in wood covered in treated plywood. The folding seats are covered in a warm, brown mat textile, giving a calm feeling to the space.

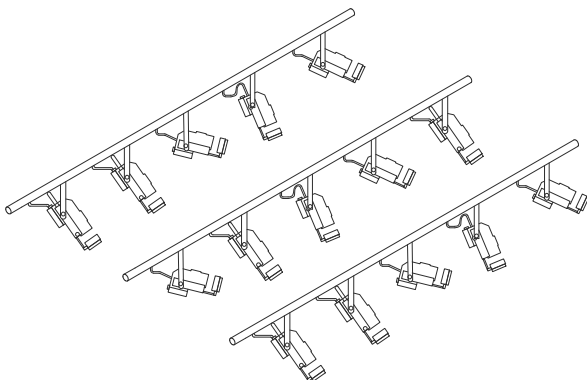

Stage light

A steel structure for stage light is fastened to the concrete beams of the structure above.

ADDITIONS FOR A PROGRAM

Additions for classrooms for music

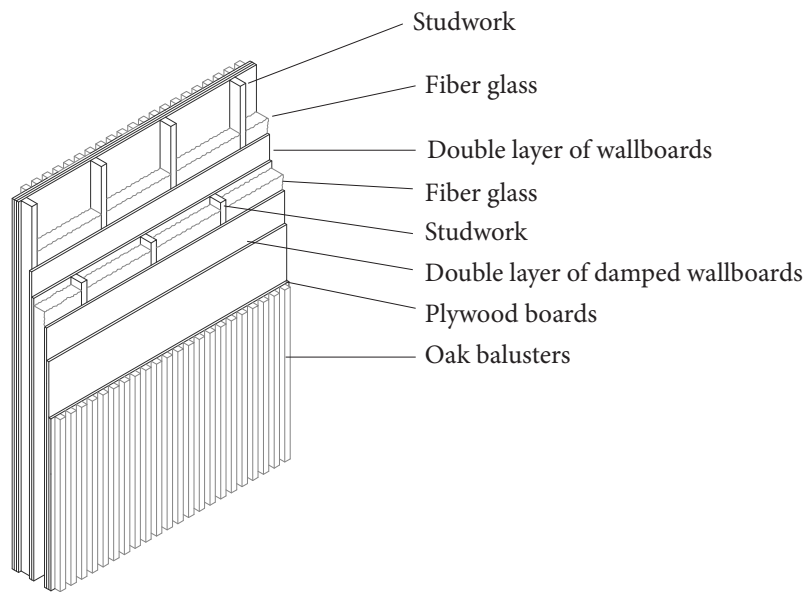

Sound insulated walls with a layer of oak balusters are added for subdividing the classrooms and rehearsal rooms for musical tutoring.

ADDITIONS FOR A PROGRAM

The classrooms for visual art

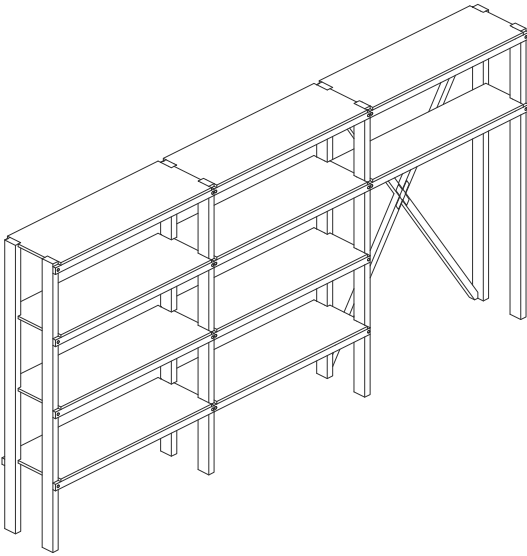

Shelves

Robust shelves of pine are installed in all classrooms for visual art. Here tools, work and material can be stored. The shelves have a regular height of 50 cm. The shelves' height, together with the things that are stored there, makes a porous installation enabling visibility. Neighbouring plateaus can get a glimpse of the activity happening behind the shelves, and vice versa. Close to the floor, rows of shelves are taken out to make space for larger installations, such as a potter's oven, or for stacking easels, canvases, or folding tables.

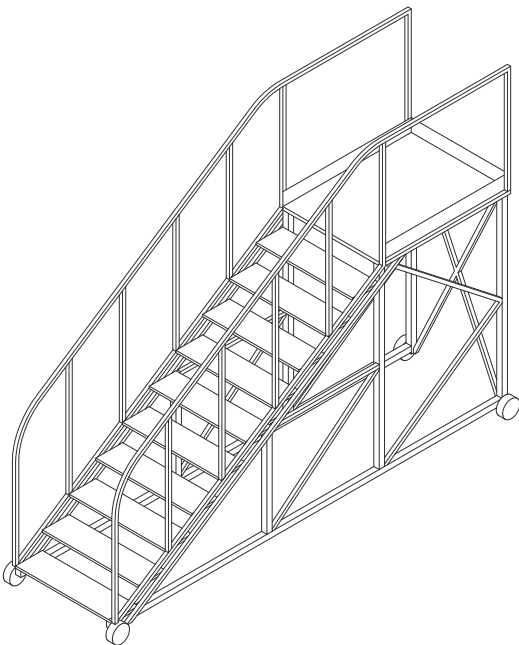

Industrial stairs

Movable industrial stairs on wheels can be used to reach for things stored at higher levels of the shelves.

Fixed stairs of the same type is added to some spaces in the building for suitable internal connections between programmes.

ADDITIONS FOR A PROGRAM

Installations for acoustic improvement

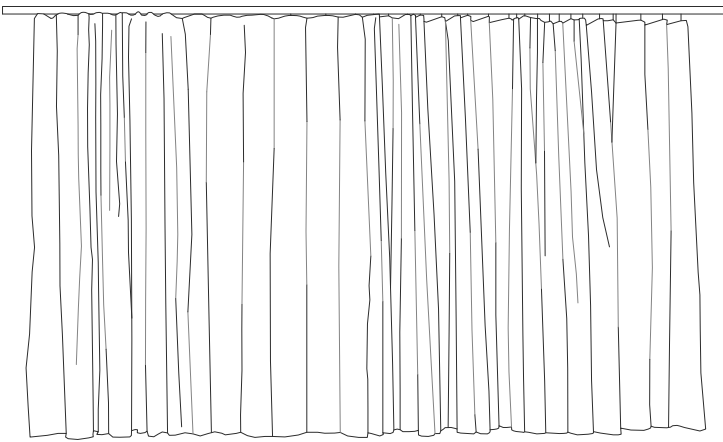

Curtains

Large curtains of wool are installed in different classrooms. Hanging in corners, they absorb sound as they prevent sound waves to bounce between walls. The curtains can be drawn for further sound absorption, shed the light when needed, or making more private conditions for the lesson held.

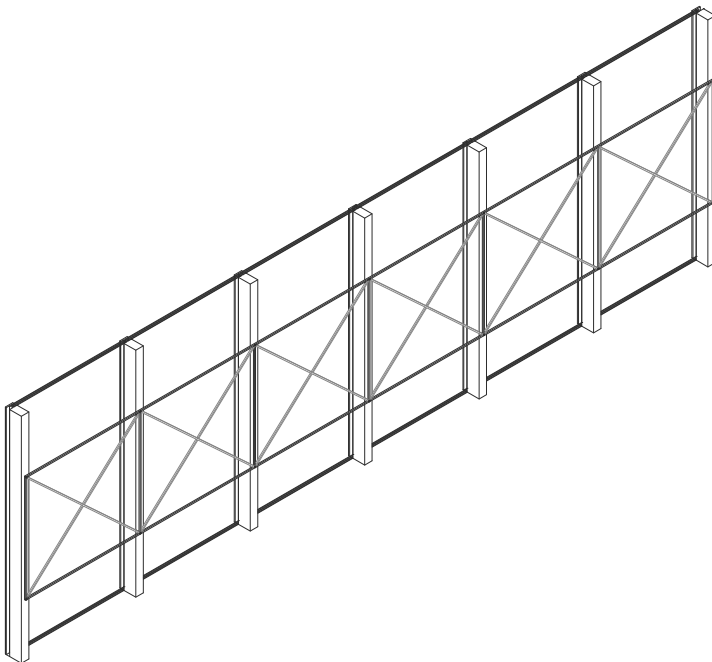

Translucent fabric panels

In wooden frames fastened to the window studs a sheer fabric is inserted to improve sound conditions by absorbing sound. The sheer fabric is a translucent fabric that lets light through and ensures visibility.

ADDITIONS FOR A PROGRAM

Installations for acoustic improvement

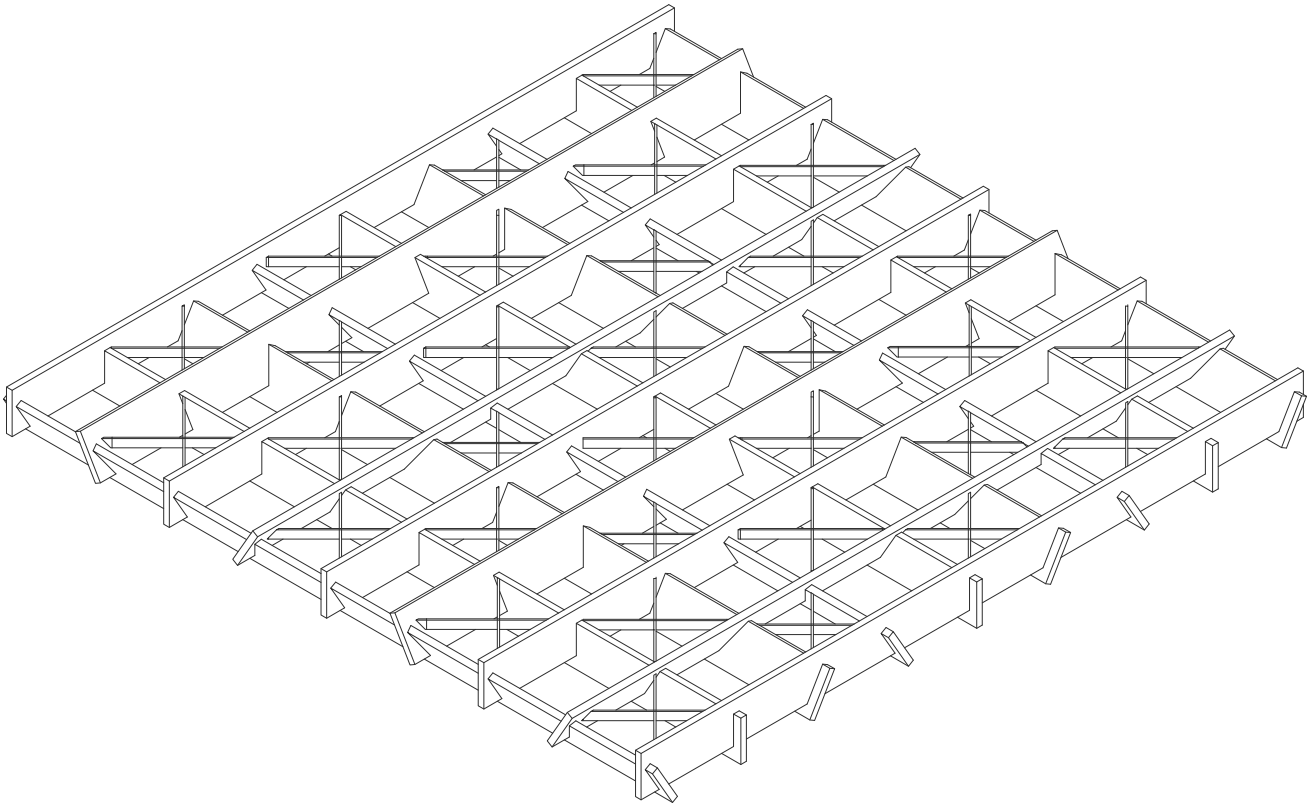

A hanging roof installation of plywood are added for improving acoustic conditions. The plywood boards have a height of 50 cm. They are inset in each other with a tilt to brake up and spread sound waves. This installation is bolted to the concrete beams above and do also incorporate other technical issues, such as leading electricity cables, carry roof lighting, direct ventilation pipes and carry speakers.