

Utopia in dystopia

Narration of an Arctic airport city

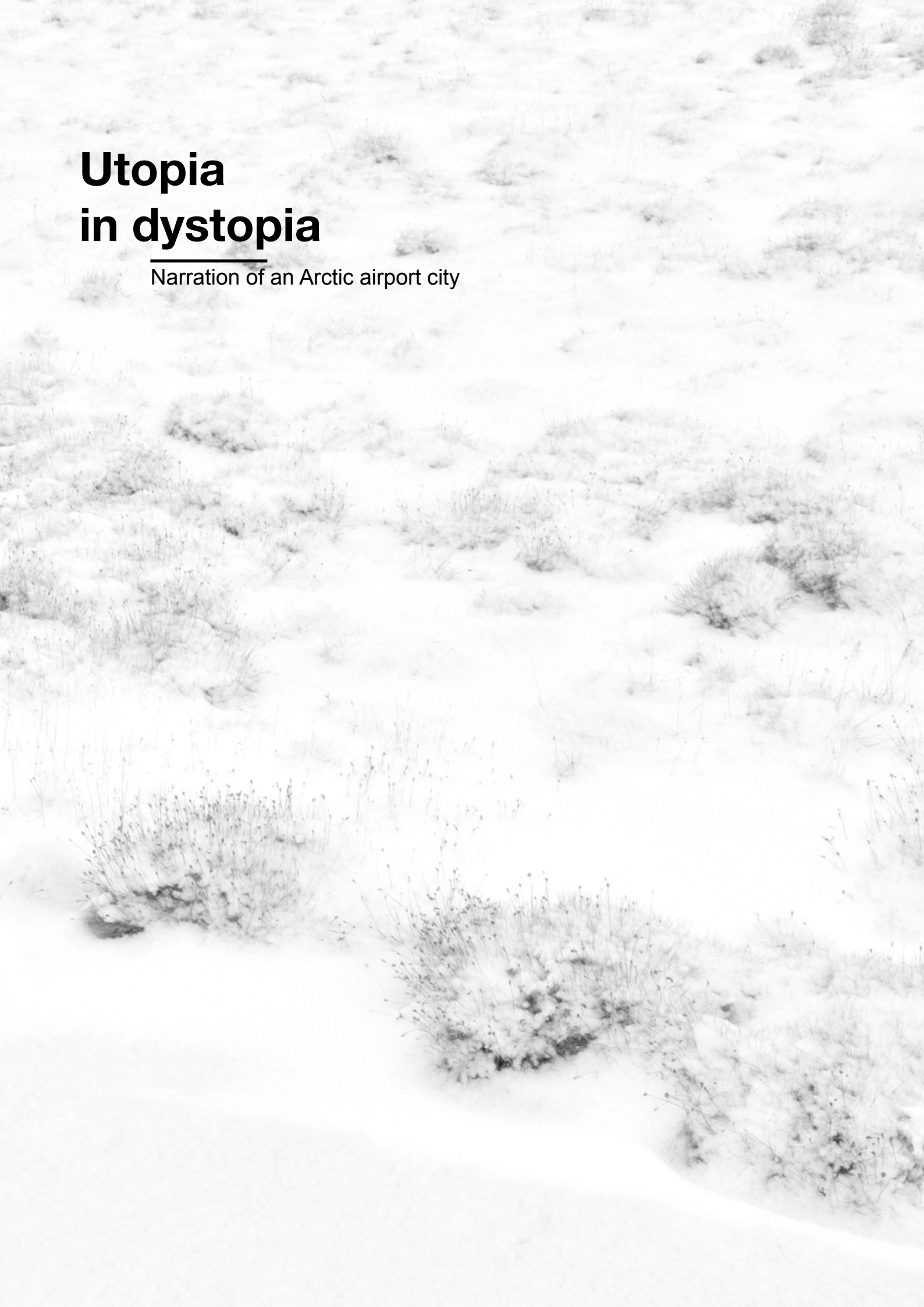

Utopia in dystopia

- Narration of an arctic airport city

Name: Zhiyuan Liu

Semester : 2017 Spring

Supervisors: Luis Callejas; Peter Hemmersam

AHO Oslo School of Architecture and Design, Institute of Landscape and Urbanism

“All material including photographs and maps, unless otherwise stated, is by the author.”

CONTENT

<i>Preface</i>	3
<i>The unpredictable</i>	5
<i>Landscape patterns and slush risk interface</i>	7
<i>Avalanche risk</i>	8
<i>Tomorrow is not promised</i>	10
<i>The existence of an Arctic city</i>	12
<i>The vernacular language of site</i>	14
<i>The relocation plan</i>	16
<i>Airport cities expansion</i>	18
<i>Airport cities EU</i>	20
<i>Airport cities NORWAY</i>	22
<i>Configuration</i>	24
<i>Structure</i>	26
<i>Terminals</i>	28
<i>Cities without boundary</i>	30
<i>TOS</i>	32
<i>OSL</i>	34
<i>Ice break and harbour</i>	36
<i>terminal types</i>	38
<i>Existing urban patterns</i>	40
<i>Terminals</i>	42
<i>Insight of risks buildings</i>	44
<i>Design of disassemble</i>	46
<i>Slop mitigation tipotype</i>	48
<i>Processing of Arctic airport city</i>	50
<i>LYR masterplan</i>	52
<i>Site section I</i>	54
<i>Site section II</i>	56
<i>Site section III</i>	58
<i>Iso</i>	60





Preface

The un- predictable

The winter of 2015, avalanches happens without notice and any alarm in advance. Residents life is posed under risks.

Avalanches often follows almost the same path from year to year. Especially in recent year it happens more frequently.



Photo: Svalbardposten

ISFJORDEN

15° 20' E

15° 40' E

ADVENTDFJORDEN

Adventcity

Operafjellet

CRUISE
BERGEN 2022 Km
TROMSØ 958 Km
AROUND SPIRITSBERG

Start

Airport

Longyearbyen

TOURISM
OSLO 2042 Km
TROMSØ 958 Km

17° 13' N

Gruve 3

Plataberget

Gruve 1

Gruve 2a

Gruve 2b

Lake

ADVENTDALEN

17° 11' N

Gruve 4

Longyearbyen

Gruve 5

Gruve 2

TREKKING

Longyearbyen

Larsheien

Gruve 3

Gruve 6

Gruve 7

Håberget

Kal bay fjellet

Carl Lundh
fjellet

SNOWMOBLIE
SAFARI

Longyearbyen
River
5 Km

17° 07' N

4 Km

Longyearbyen Historical Development

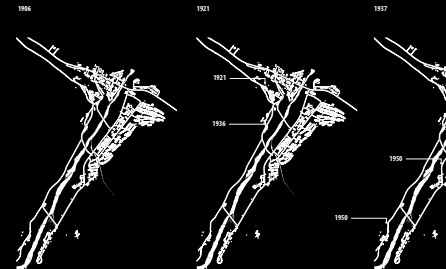

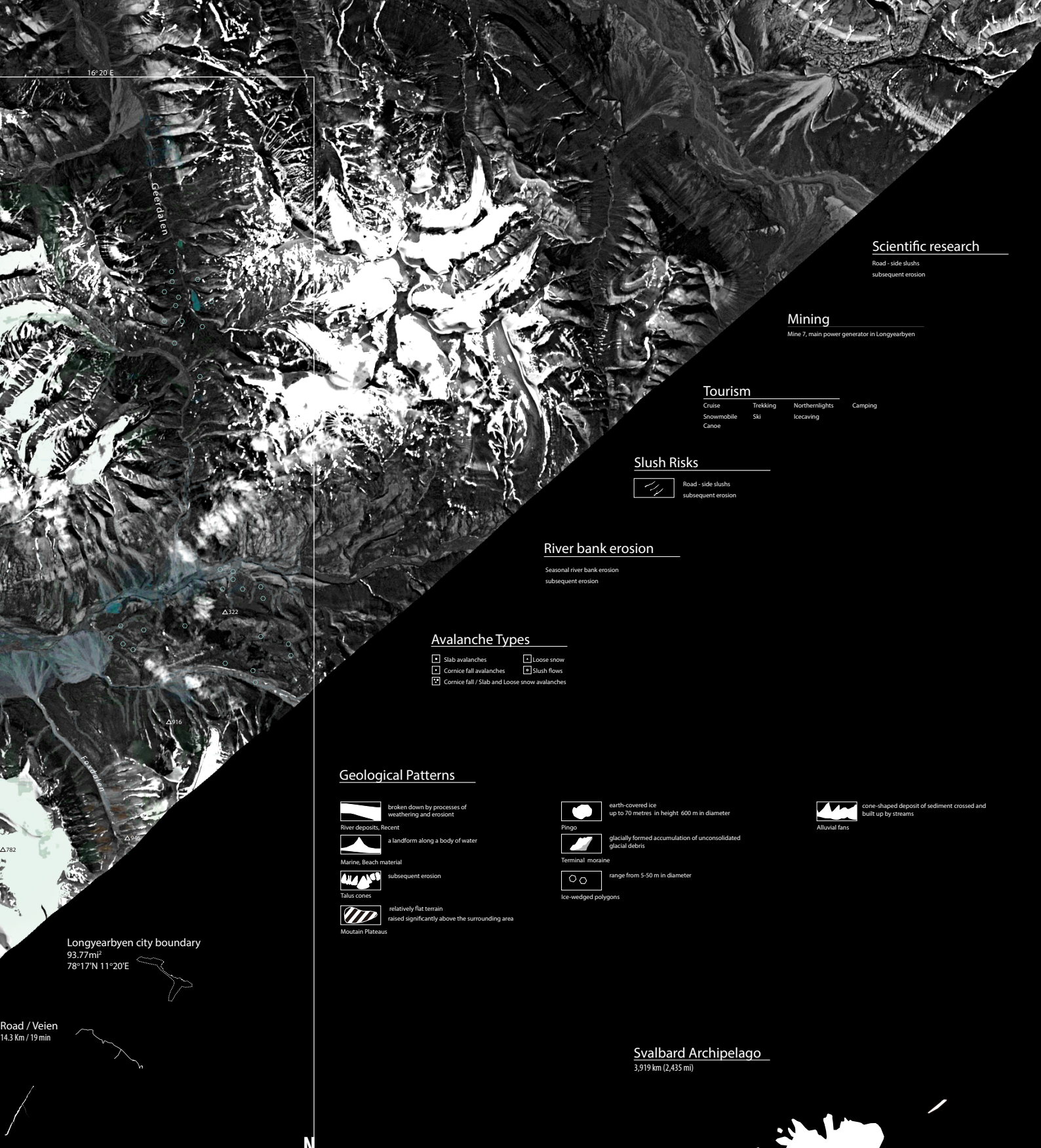

16° 20' E

Geofraalen

Scientific research

Road - side slushs
subsequent erosion

Mining

Mine 7, main power generator in Longyearbyen

Tourism

Cruise Trekking Northernlights Camping
Snowmobile Ski Icecaving
Canoe





Slush Risks

 Road - side slushs
subsequent erosion





River bank erosion



Seasonal river bank erosion
subsequent erosion

Avalanche Types

-  Slab avalanches
-  Cornice fall avalanches
-  Cornice fall / Slab and Loose snow avalanches
-  Loose snow
-  Slush flows

Geological Patterns

-  River deposits, Recent
-  Marine, Beach material
-  Talus cones
-  Mountain Plateaus

-  Pingo
-  Terminal moraine
-  Ice-wedged polygons

-  Alluvial fans

Longyearbyen city boundary
93.77 mi²
78°17'N 11°20'E

Road / Veien
14.3 Km / 19 min

Svalbard Archipelago

3,919 km (2,435 mi)

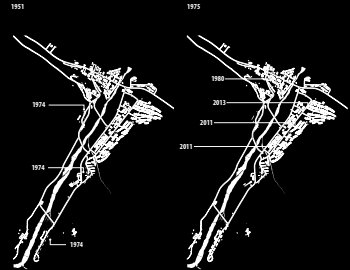

Landscape patterns and slush risk interface, situation between airport and city.
GEOLOGICAL, LANDSCAPE PATTERNS, SLUSH AND AVALANCHE RISKS INTERFACE

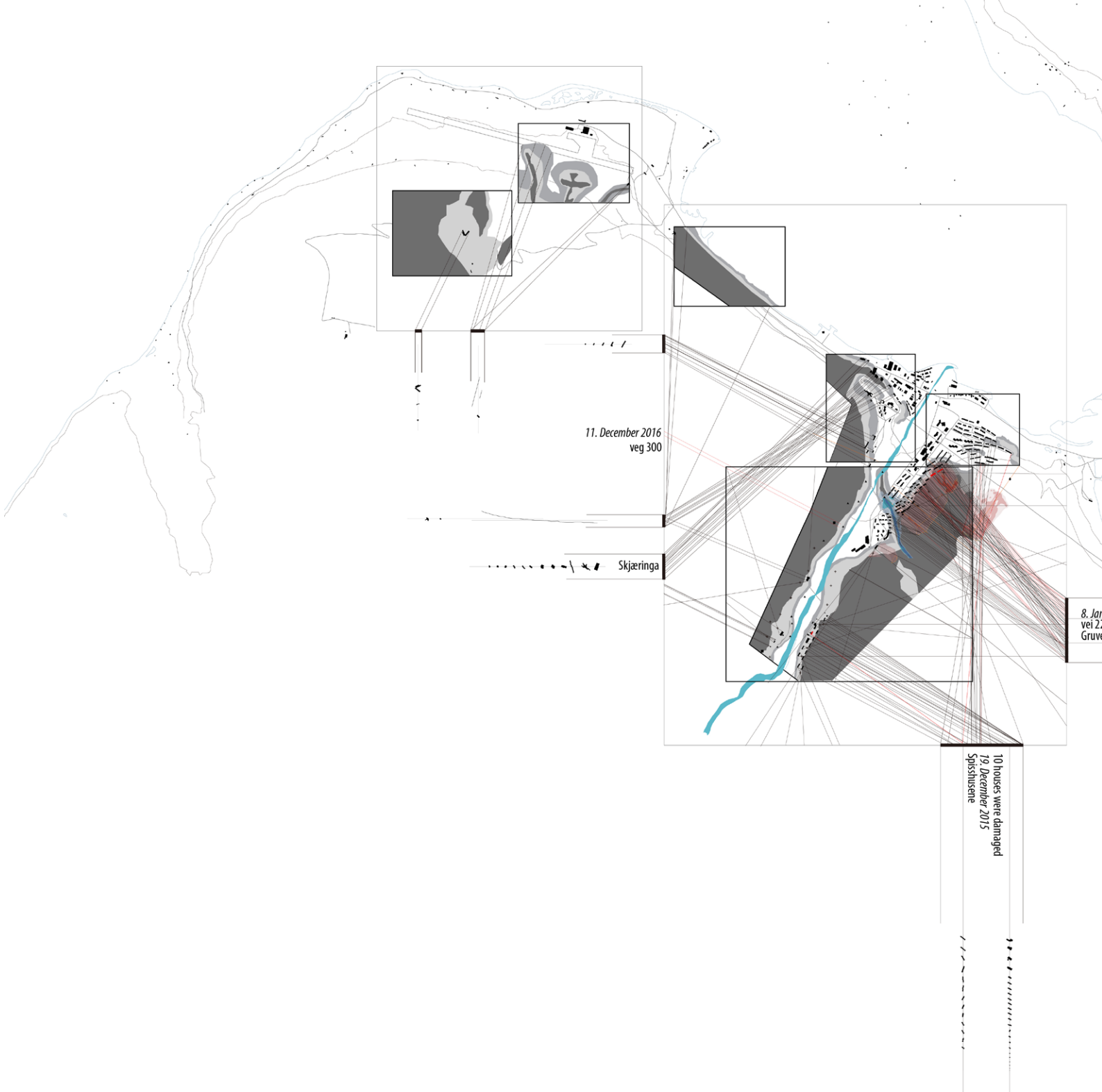

Avalanche risk

Longyearbyen, Svalbard

Risk area in the big Longyearbyen area.

January 2016
28
edalen



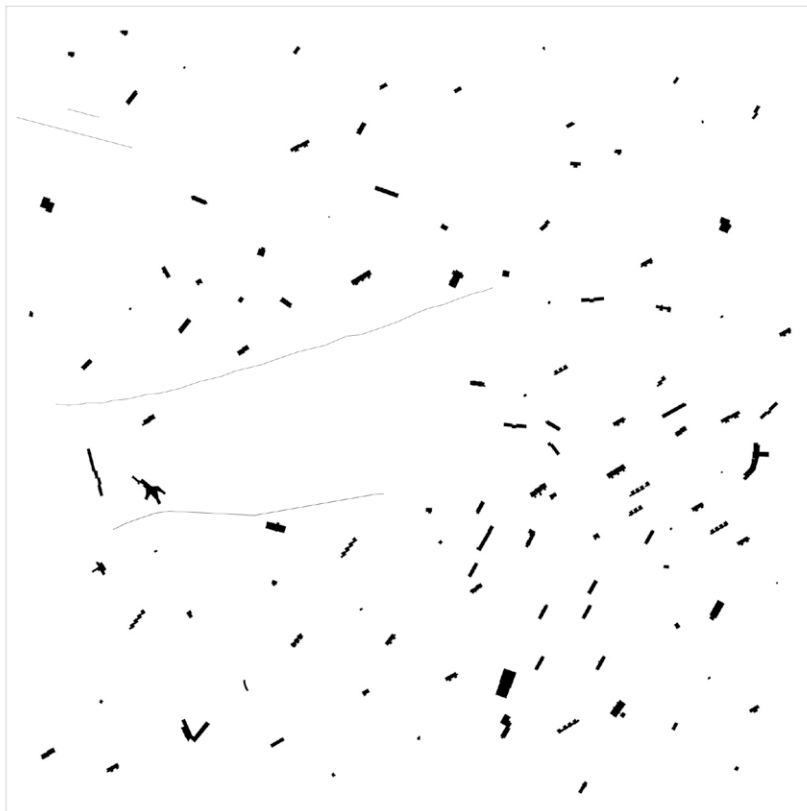

Tomorrow is not promised
Abstraction
vulnerable Houese and roads
78°13'N 15°33'E

Tomorrow is not promised

Abstraction

Vulnerable houses and roads

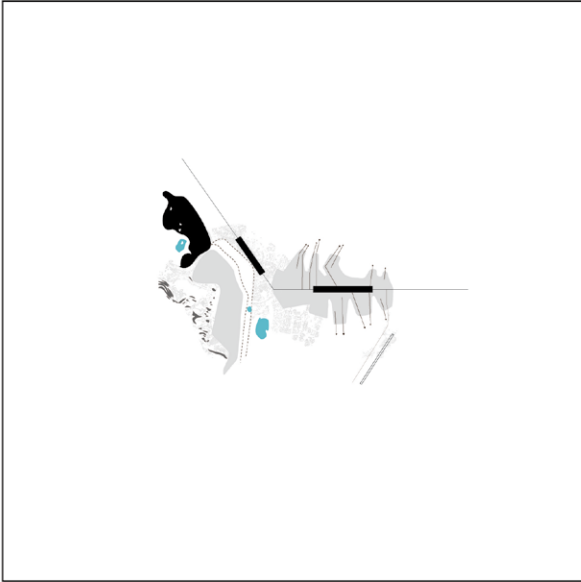

KIRUNA
Sweden, White / Ghafari + Hellmuth Obata Kaser AS
Relocation

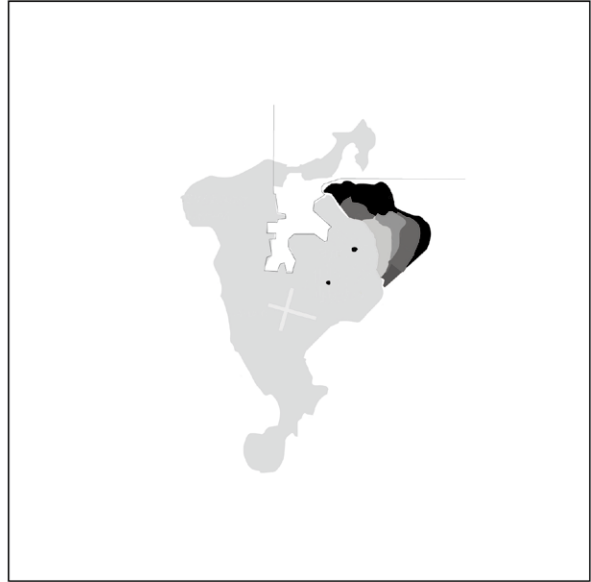

HEIMAËY ISLAND
Iceland, Lusa Cooling Operations
Defense

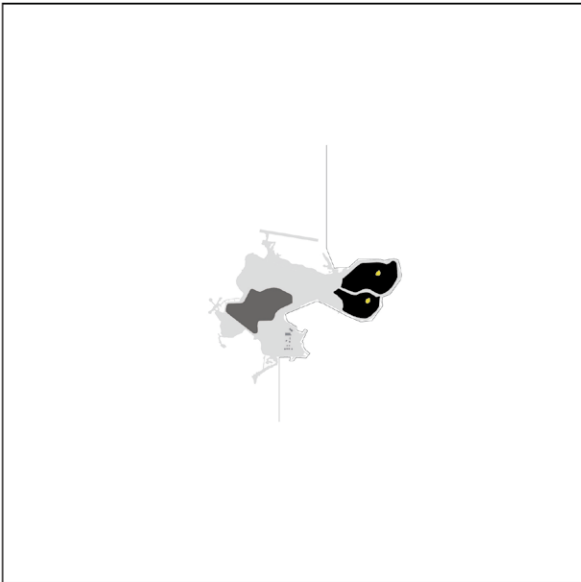

DIAVIK DIAMOND MINE
Canada. Huge water retention dikes were constructed to safeguard mining facilities and accommodations.
Reinforcement

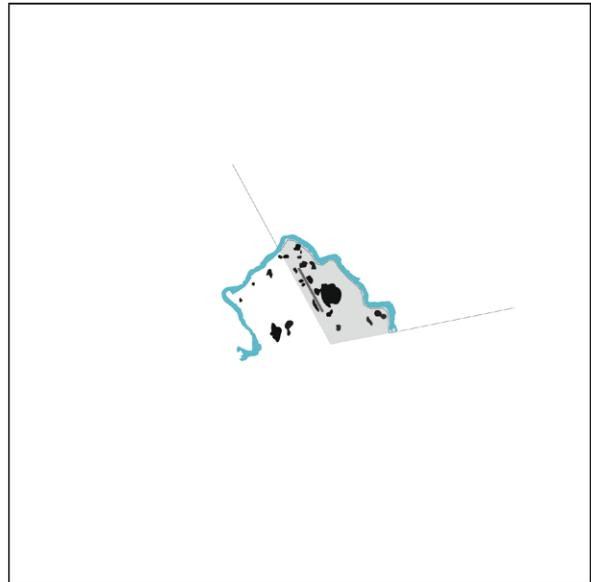

NEWTOK
Alaska, Coastal Erosion
Abandon

The existence of an Arctic city

KIRUNA, SWEDEN

Relocation

HEIMAEY ISLAND

*Dfence
lava-cooling operation*

DIAVIK DIAMOND MINE, CANADA

*Reinforcement
Huge water retention
dikes were constructed
to safeguard mining
facilities and
accomodations.*

NEWTOK, ALASKA

*Abandon
Coastal Erosion*

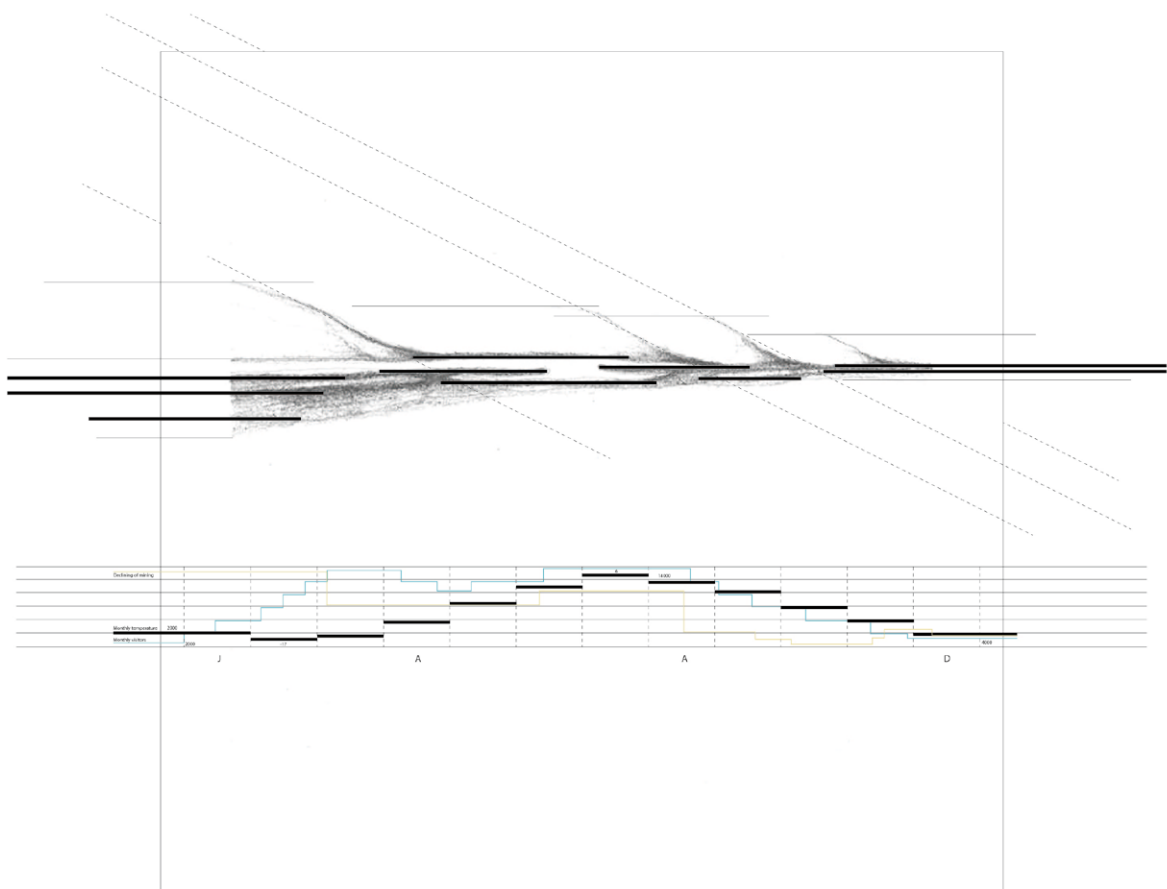

The Vernacular Language of the Landscape

Spatial and morphological characters through the longyearbyen Gemometries

Study Sketches

Study Sketches of the volume and Shape through the scene & Geology

The Vernacular Language

In spite of the decreasing of long history of mining industrial, scientific research and tourism is increasing. During the summer time the airport and the city is experiences a very high traffic peak.



Relocation

Mitigation

Relocation

Abandon

The action

A relocation plan of the risk communities to the airport is triggered, a relatively safe area in the extreme Arctic climate. It's not only considering the demand of further airport capacity and the safety of risk resident. It also an opportunity to experiment the development of an Arctic city.

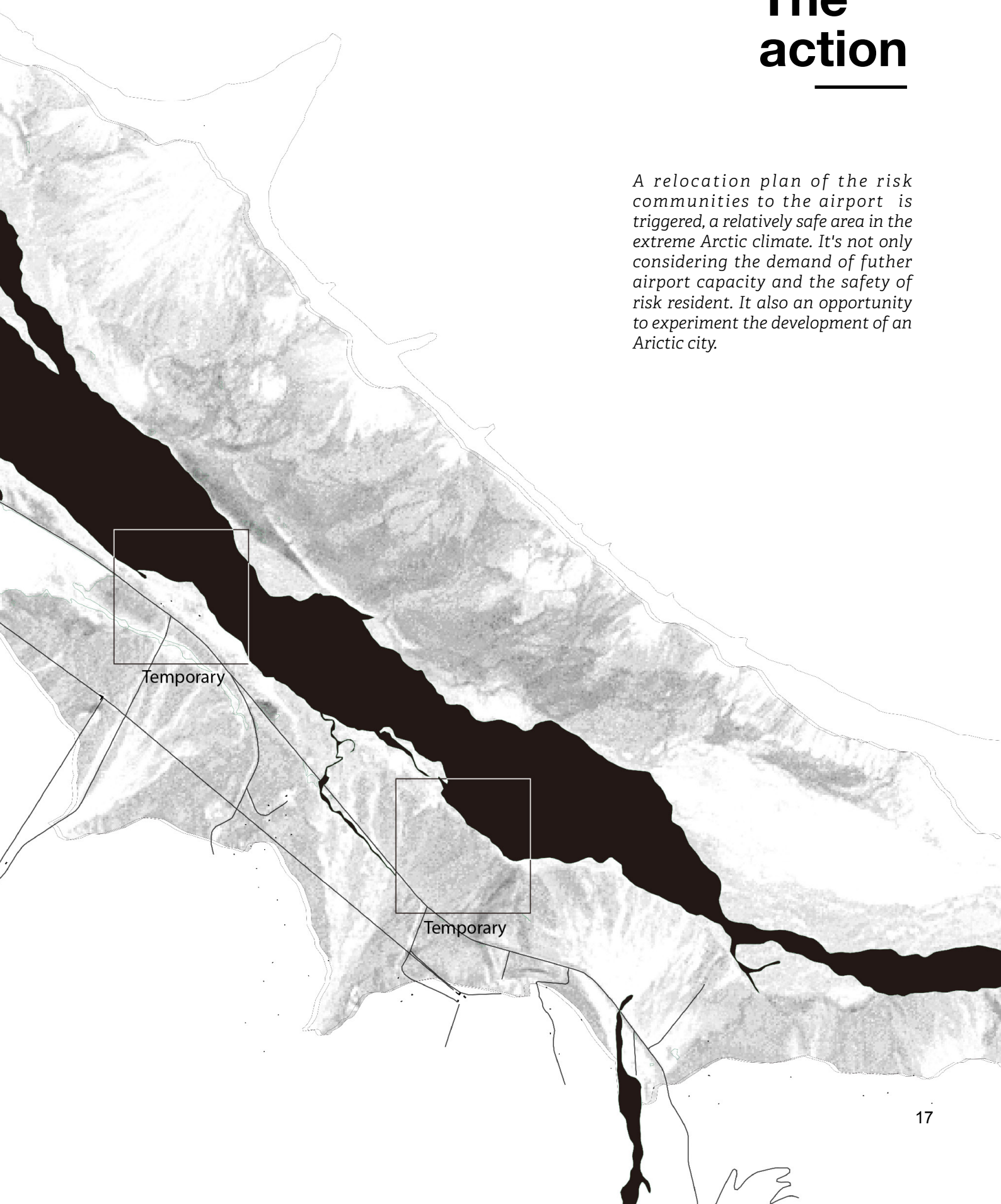



AMS
COLLABORATION

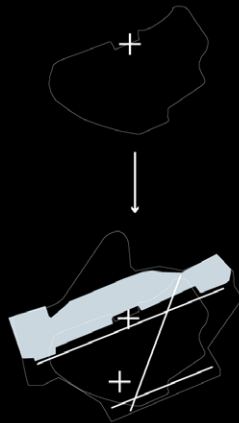

BCN
EXPANSION

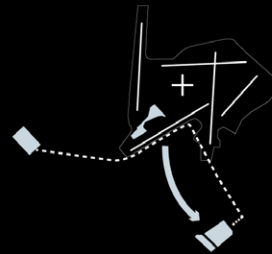

AMS
OUTSOURCING

MORPHOLOGY TO EXPAND CAPACITY

TERMINAL DEVELOPMENT

Airport cities Expansion

Expansion

Different type of airport cities expansion.



ZRH

Dispers non-operational area
 Low accessibility
 Island(Remote) terminal



LGW

Dispers non-operational area
 Airport cities around the Airfield



OSL

Terminal domained by airfield
 Airport city confined by airfield
 Transit within terminal



VIE

Alternative development of runway
 Linear airport city
 Transit within terminal

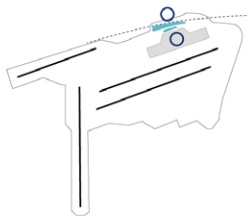

FRA

Highly interchange
 AirRail Terminal
 Sky city



AMS

Distributed across territory
 Distributed over several site of the platform



BCN

Compact Airport city
 Compact and concentrated



ARN

Designated logistic area
 Areas for airport-related logistic and business activities
 Being developed with collaboration

AIRPORT CITY PATTERNS

Airport cities EU

Configuration

*Different type of airport cities in
the Europ context.*

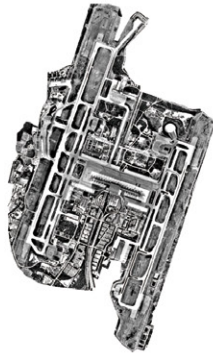

OSL



BGO

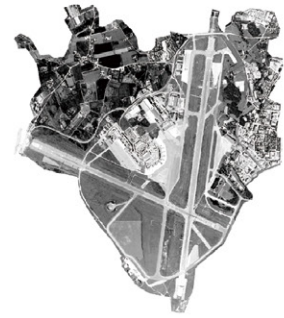

SVG



TOS

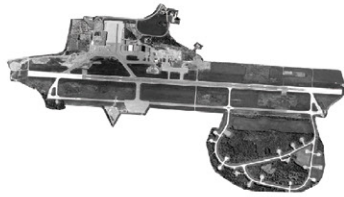

TRF

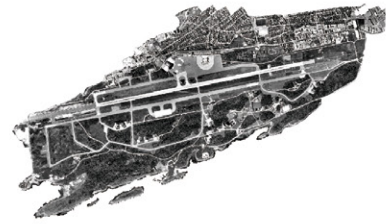

BOO

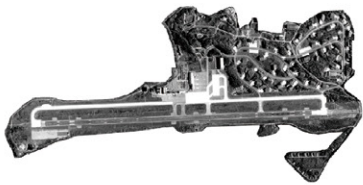

EVE



ALF

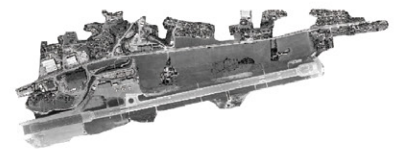

MOL

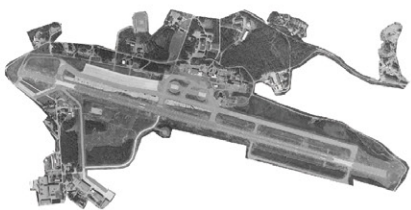

BDU

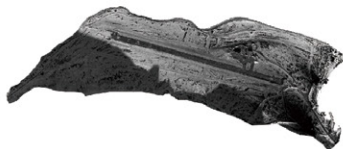

LYR

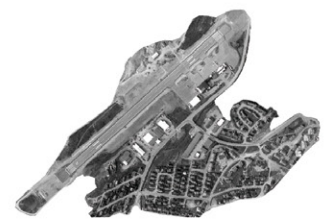

HFT

Airport cities NORWAY

Configuration

Selected norwegian airports analysis

Airport cities often combines different types configurations response to the demand of use. More condensed area near the terminl while more loose in the other side of the runway.

The topotype urbanism structure also can be seen: grid / linear / Radiate / Cluster and so on.



TRD

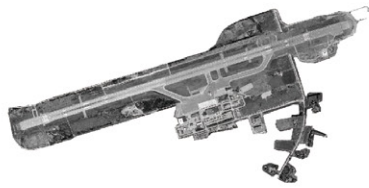

AES



KRS

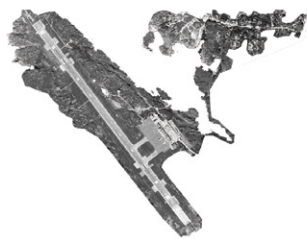

HAU



KSU



KKN

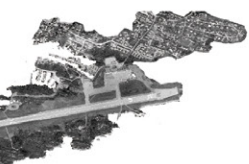

FRO



SKN



HAU

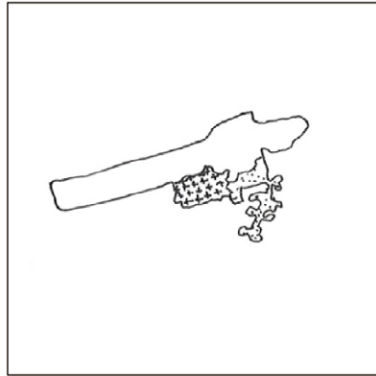

AES



KRS



MON

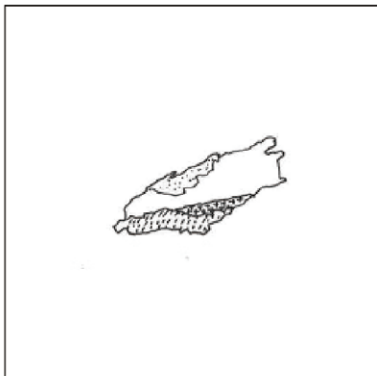

BOO

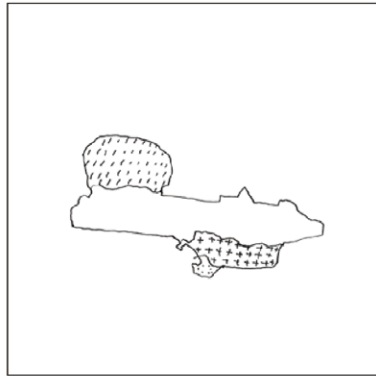

TRF



TOS



HFT

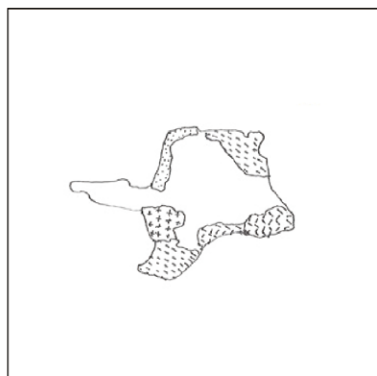

TRD

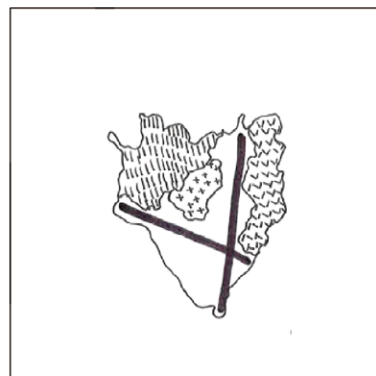

SVG



BGO



KKN



MOL

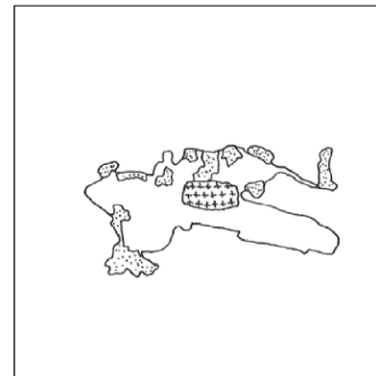

BDU

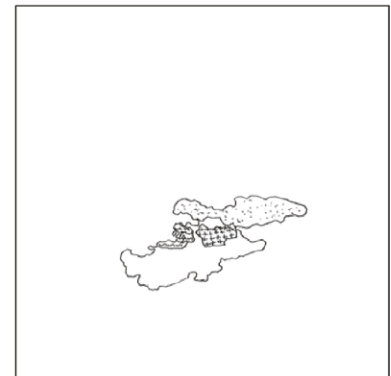

FRO



ALF

Airport cities NORWAY

Configuration

*Selected norwegian airports
analysis*

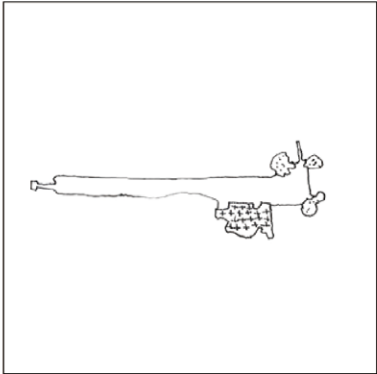
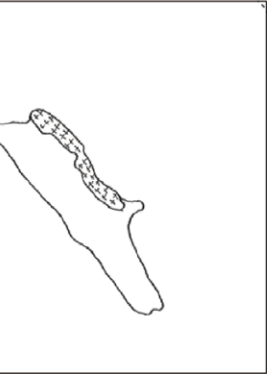

SKN

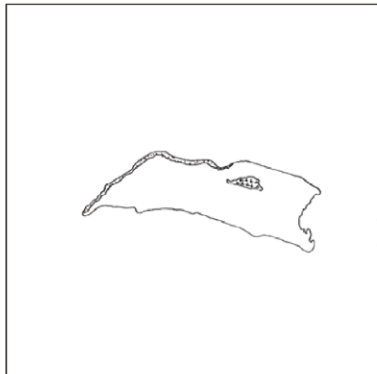

LVR

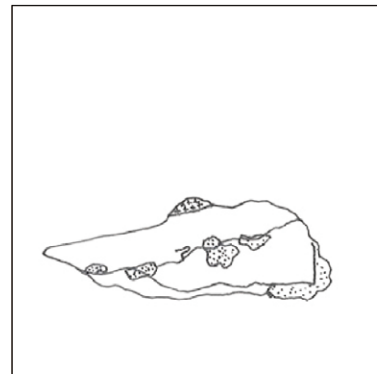

KSU

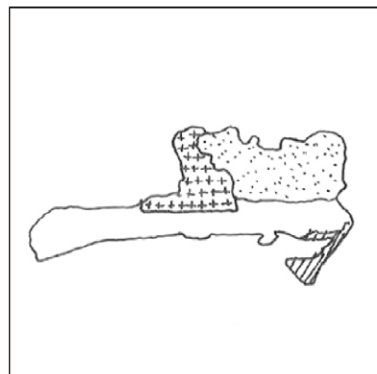

EVE

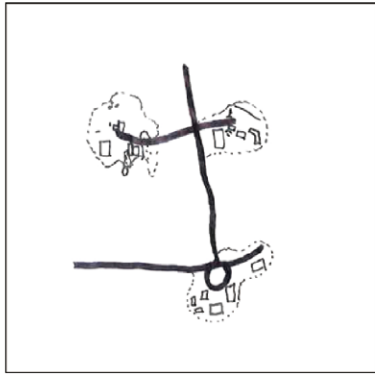

SKN

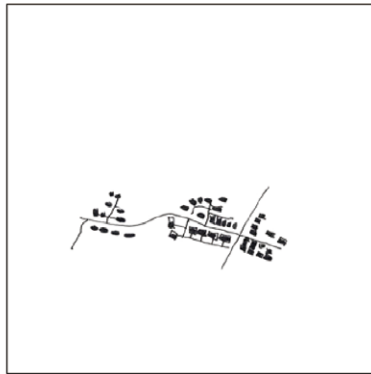

FRO



HFT



HAU

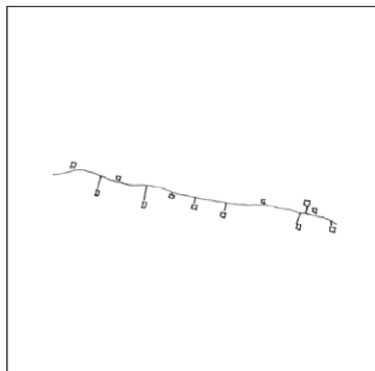

LYR



BDU

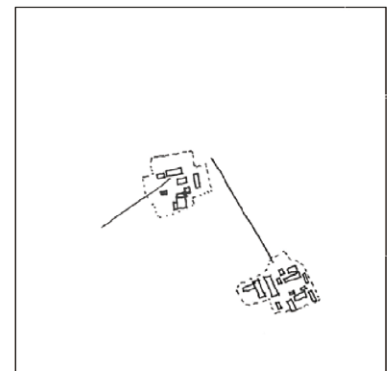

KKN



BOO

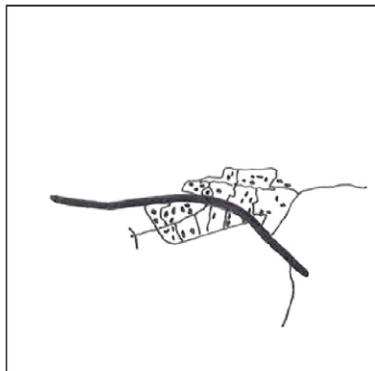

KSU



MOL



ALF



TRD

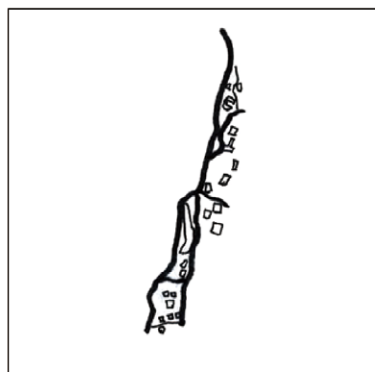

OSL



EVE

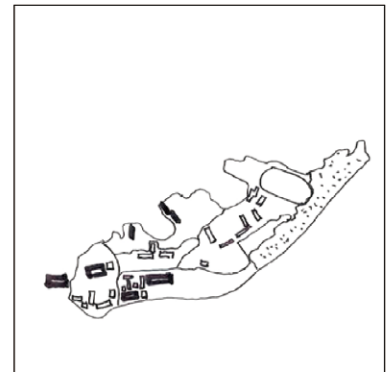

KRS



TOS

Airport cities NORWAY

Airport cities

*Selected norwegian airports
analysis*

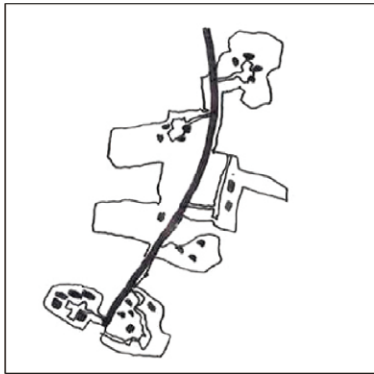

AES

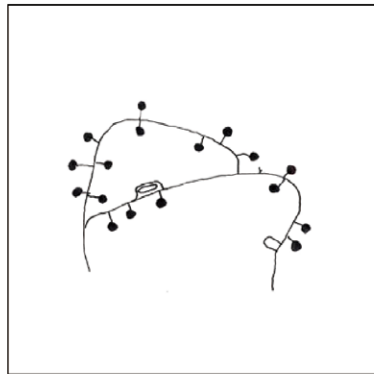

TRF



SVG

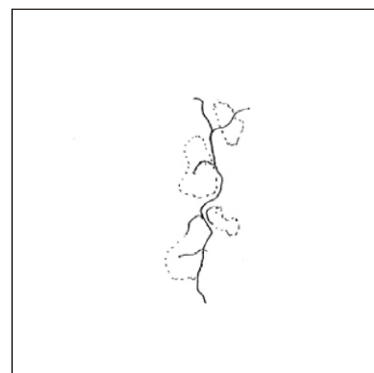

BGO

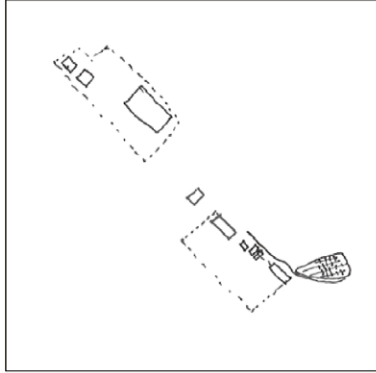

MON

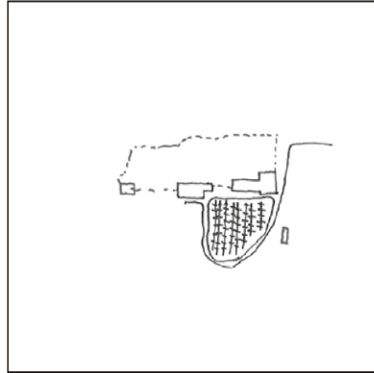

SKN

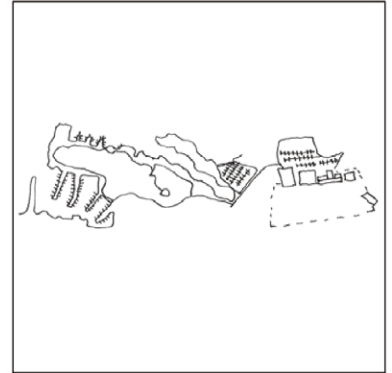

FRO



HAU

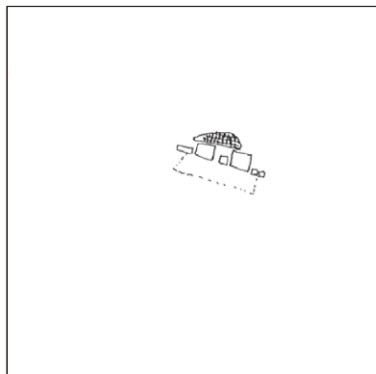

LYR

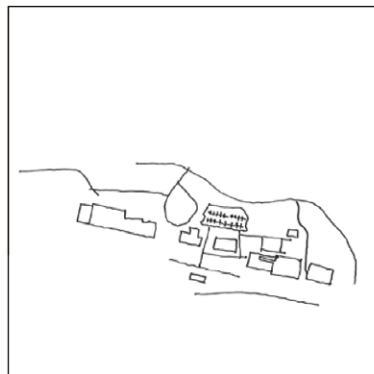

BDU

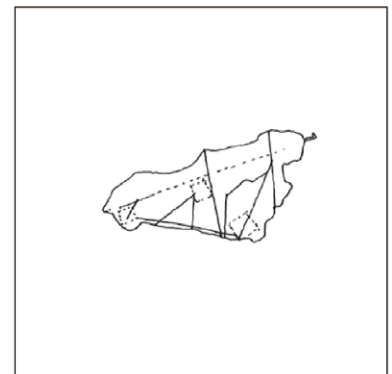

KKN



BOO

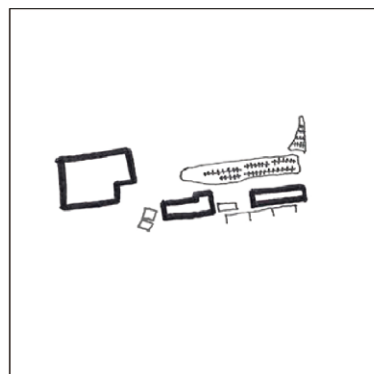
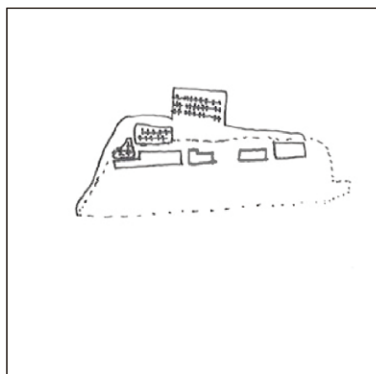

MOL

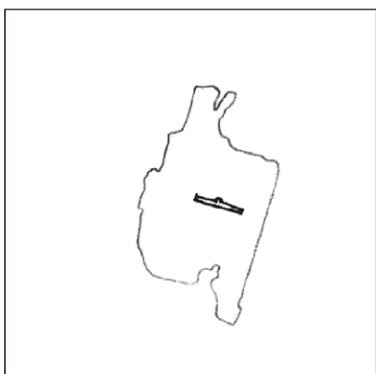
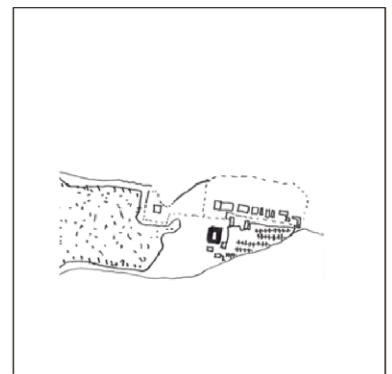

OSL

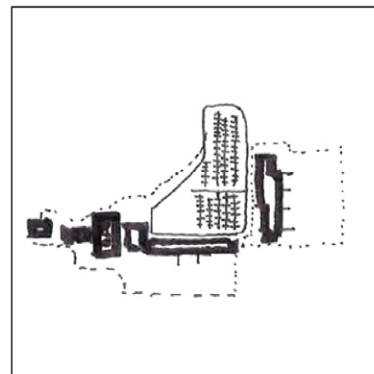

EVE

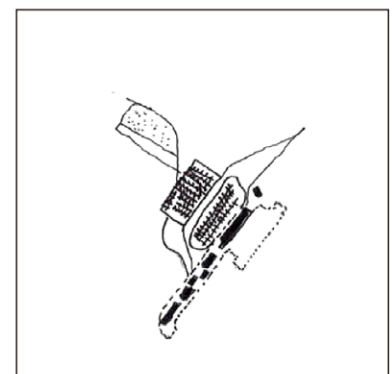

KRS



TOS

Airport cities NORWAY

Terminals

*Selected norwegian airports
analysis*

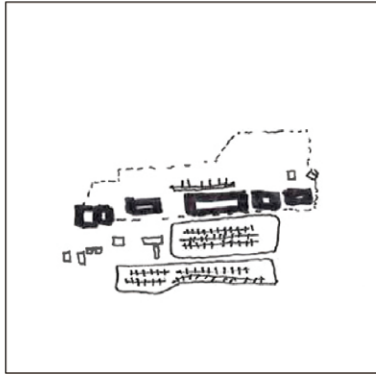
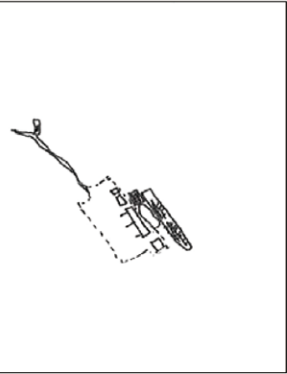

AES

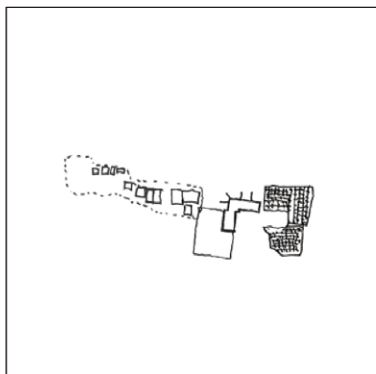
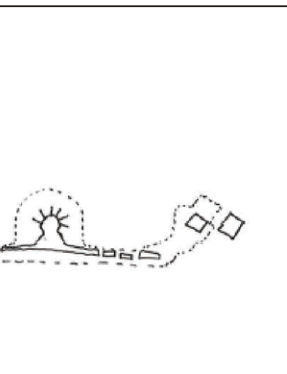

TRF

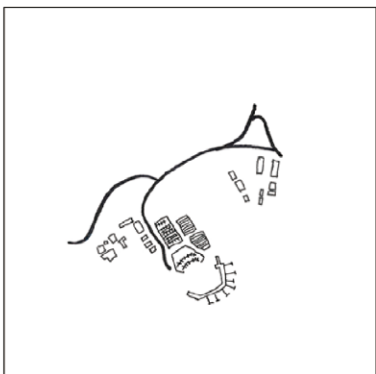
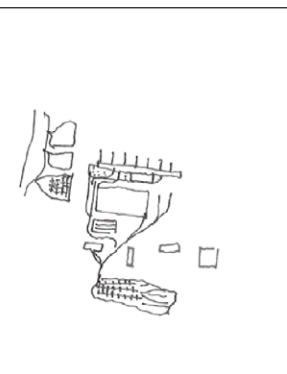

SVG

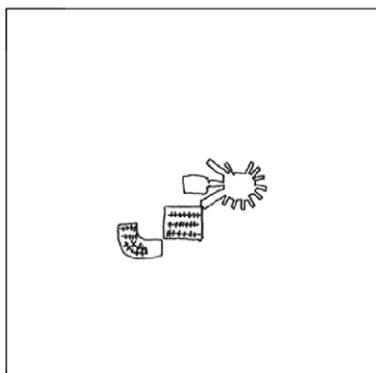
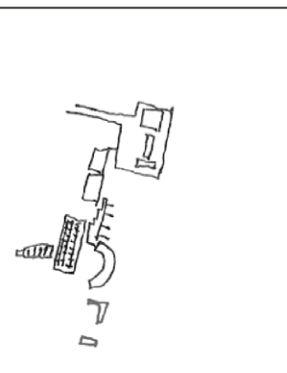

BGO

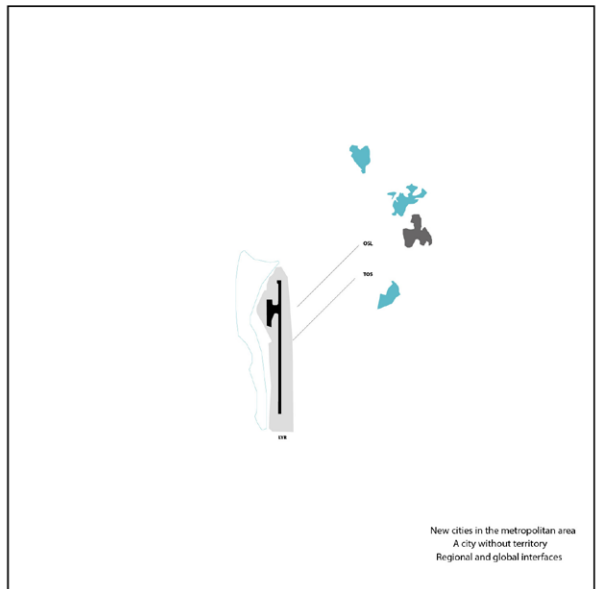
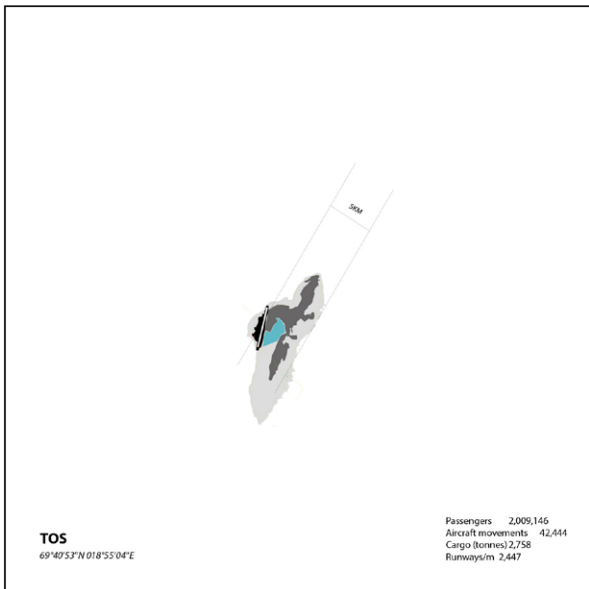
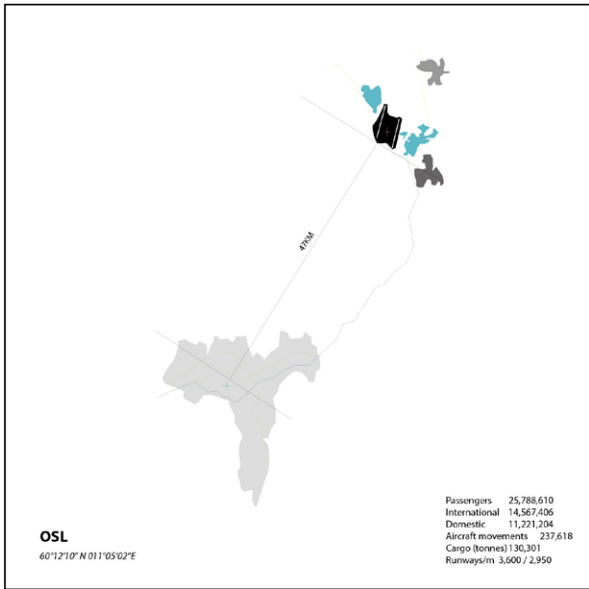

Cities without boundary

Not that far Arctic

*Regional and global
interface.*

*The closer to the airport,
more interchange between land-
side and air-side is required.*

OSL - LYR 2h50

TOS - LYR 1h42



TOS

69°40'53"N 018°55'04"E

Passengers 2,009,146
 Aircraft movements 42,444
 Cargo (tonnes) 2,758
 Runways/m 2,447

- Terminal areas
- Airport perimeter
- Reserve
- Parking
- Airport support services
- Aircraft maintenance
- Freight
- Non-aviation
- Landside development

Airport city TOS

Composition

*Airport city
Runway
Terminal
configuration*

TOS - LYR 1h42

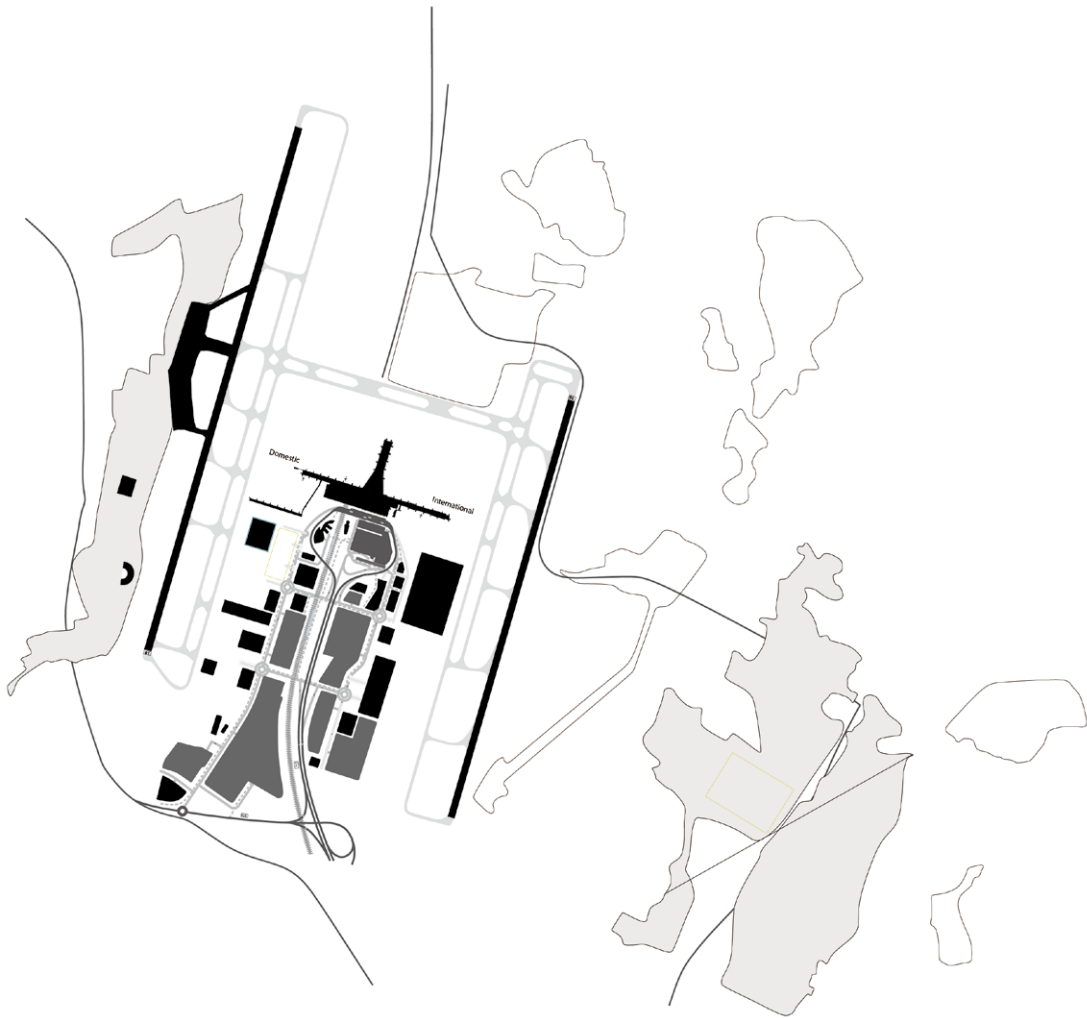

OSL

60°12'10"N 011°05'02"E

Passengers 25,788,610
 International 14,507,406
 Domestic 11,221,204
 Aircraft movements 237,618
 Cargo (tonnes) 130,301
 Runways/m 3,600 / 2,950

- Terminal areas
- Airport perimeter
- Reserve
- Parking
- Airport support services
- Aircraft maintenance
- Freight
- Non-aviation
- Landside development

Airport city OSL

Composition

*Airport city
Runway
Terminal
configuration*

OSL - LYR 2h50

Month	Activity	% of total	Determination of Existing ADPM
January	3000	2,58%	Peak month activity = 16,000 Average day activity = 516.129 (16,000 / 31 days)
February	6000	5.17%	
March	12,000	10.34%	
April	12,000	10.34%	Determination of Forecast ADPM Forecast annual activity = 20,800 Forecast peak month activity = 27,580 (20,800 x 13.79%) Forecast average day activity = 671 (20,800 / 31 days)
May	14,980	12.91%	
June	12,000	10.34%	
July	12,000	10.34%	
August	16,000	13.79%	
September	10000	8.62%	
October	8000	6.89%	
November	6000	5.17%	
December	4000	3.44%	
Annual total	115.980	100%	

Terminal capacity calculation

Annual activity can be used to determine order-of-magnitude facility requirements

Forecasting terminal capacity

Site analysis

Future capacity expansion

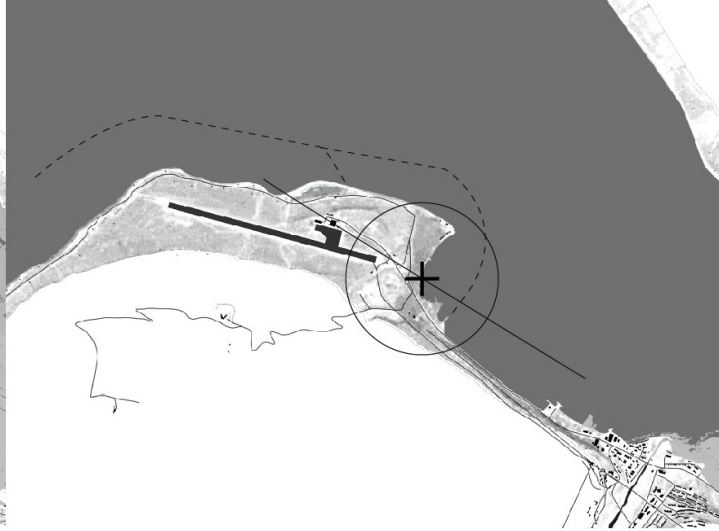
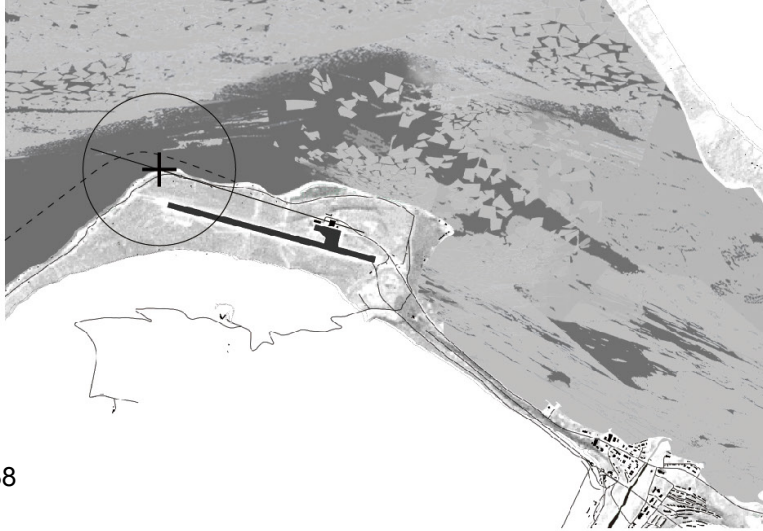
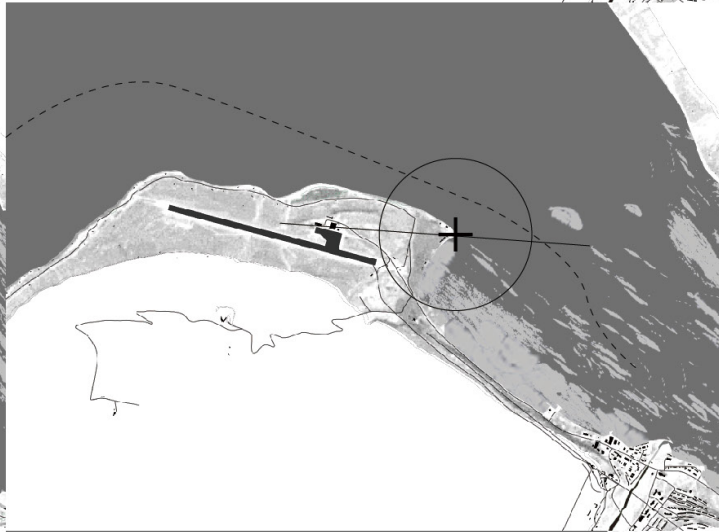
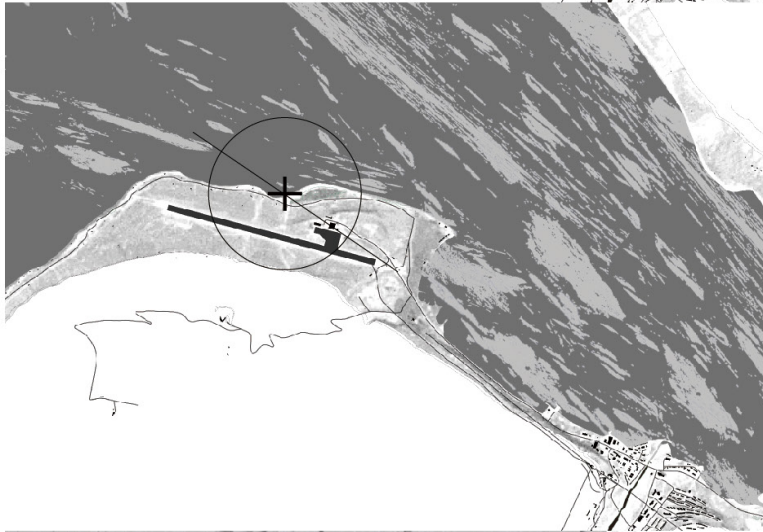
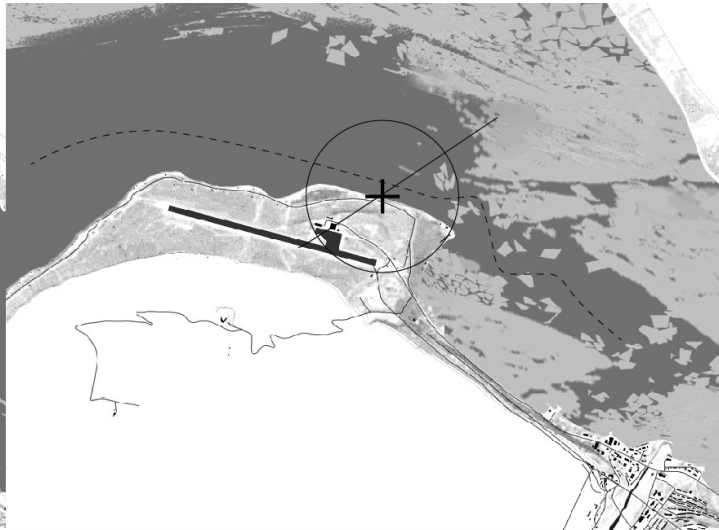
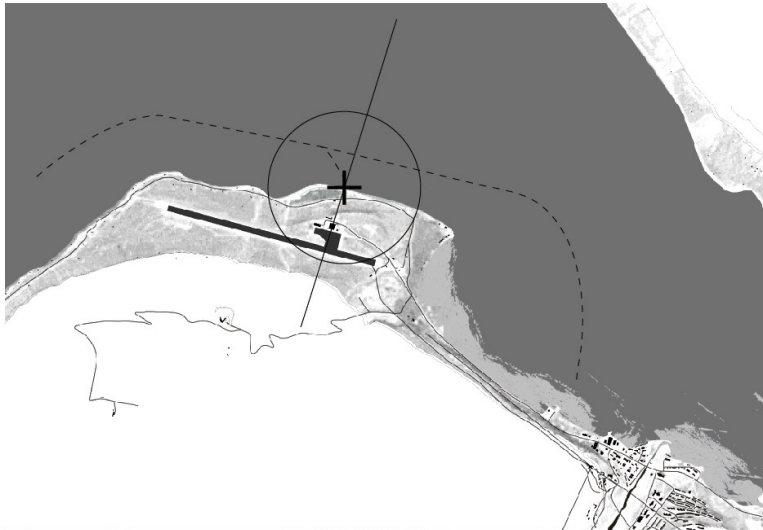

Ice break and Harbour

Configuration

*Different type of airport cities in
the Europ context.*

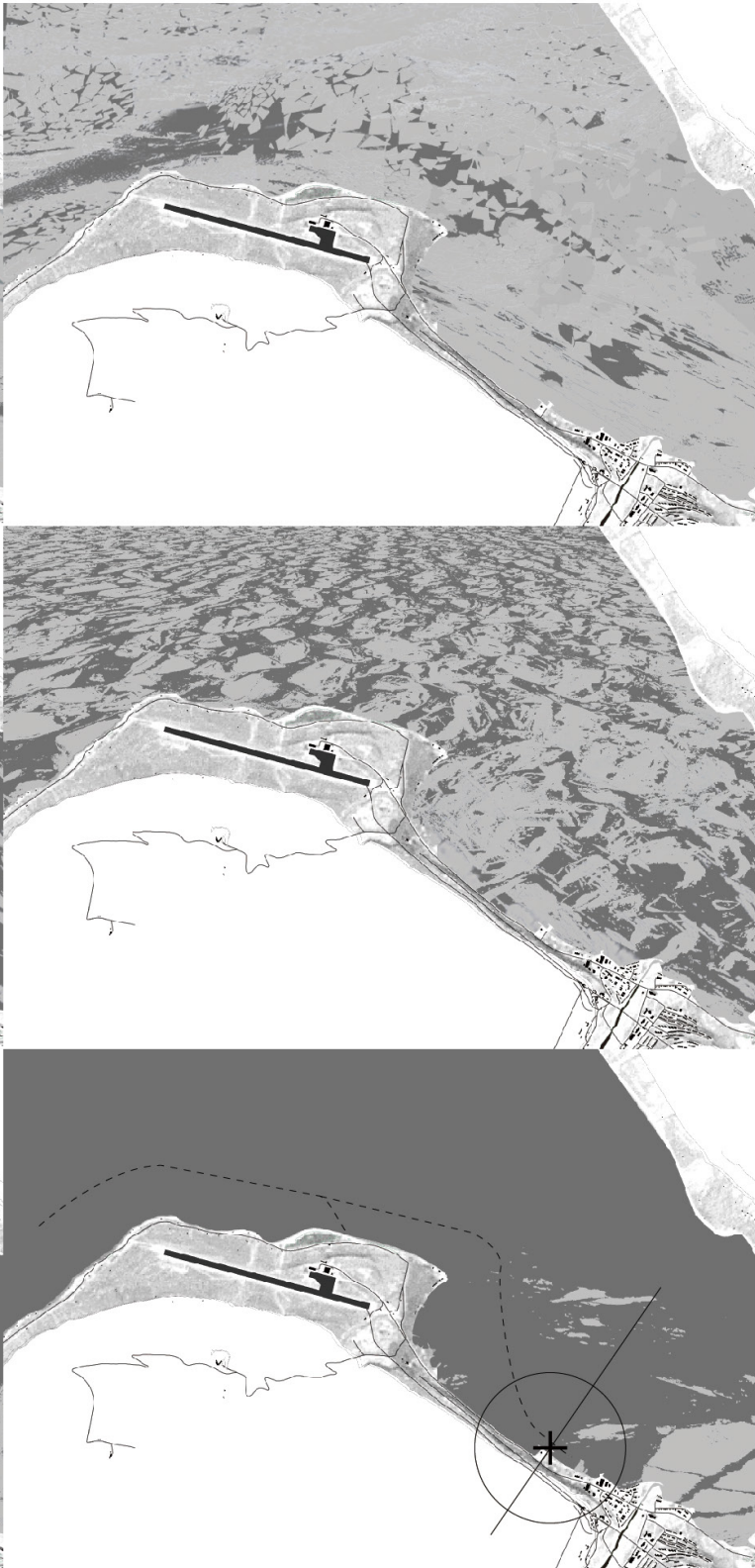

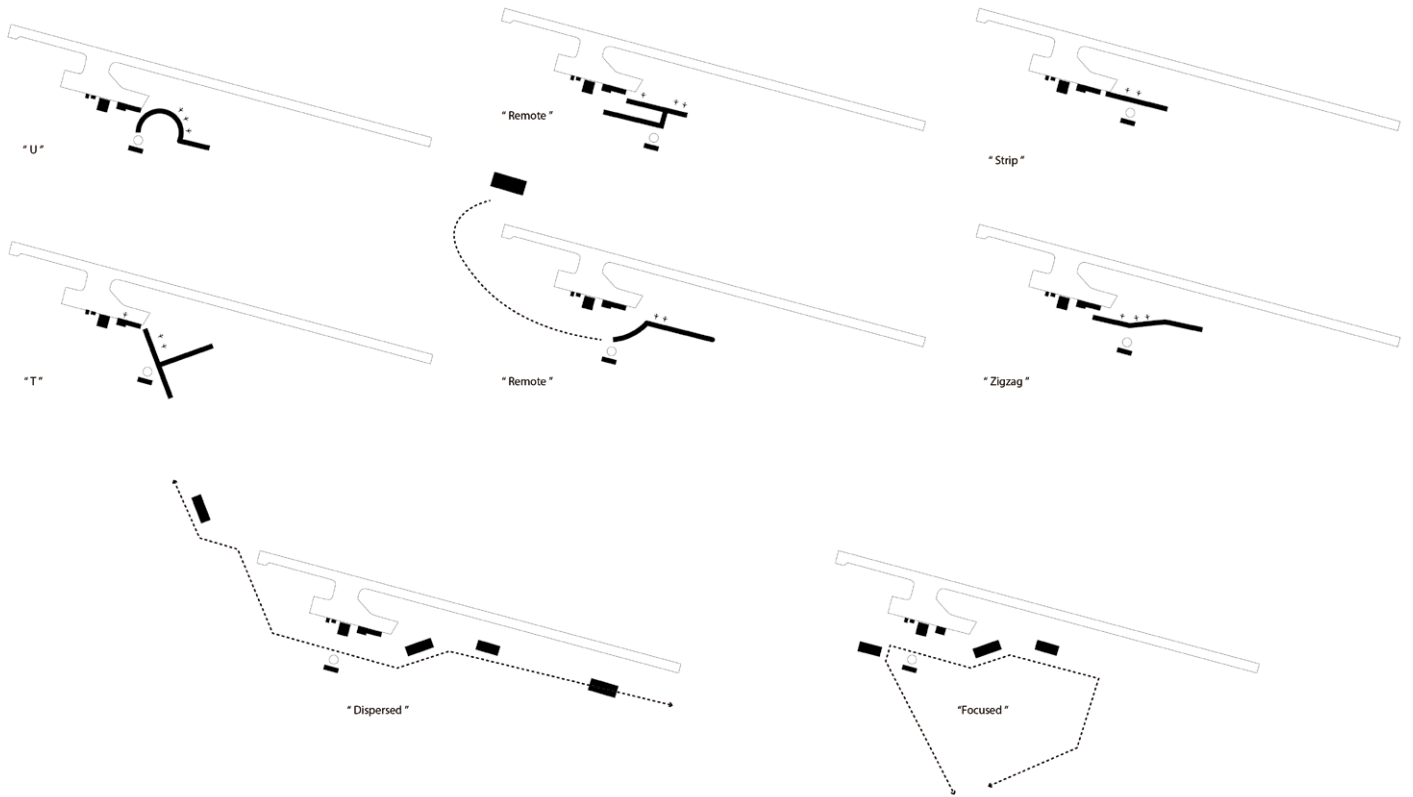

Platform - Focused Approach

Airport logistic prefer a platform focused approaches

Terminal expansion

Focused

A focused platform enables high interchange activities. In the Arctic context which reduces distance when weather condition is not good. Offers high accessibility.

Nybyen

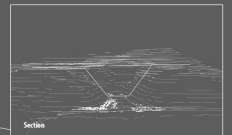
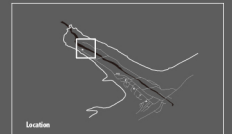
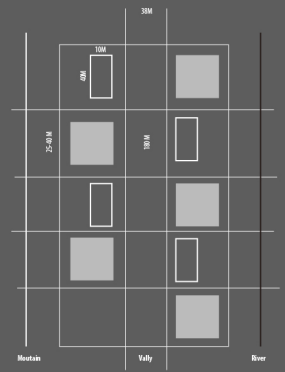

SINGLE BUILDING UNIT
3.00M

SPACE AND SURROUNDINGS
Local topography

BUILDING CONFIGURATION
Section view

SPACIAL QUALITY

SHADOW EFFECTS
100% shadow at 12:00

TEMPERATURE
100% shadow at 12:00

SHADOW EFFECTS
100% shadow at 12:00

WIND DIRECTION
10:00

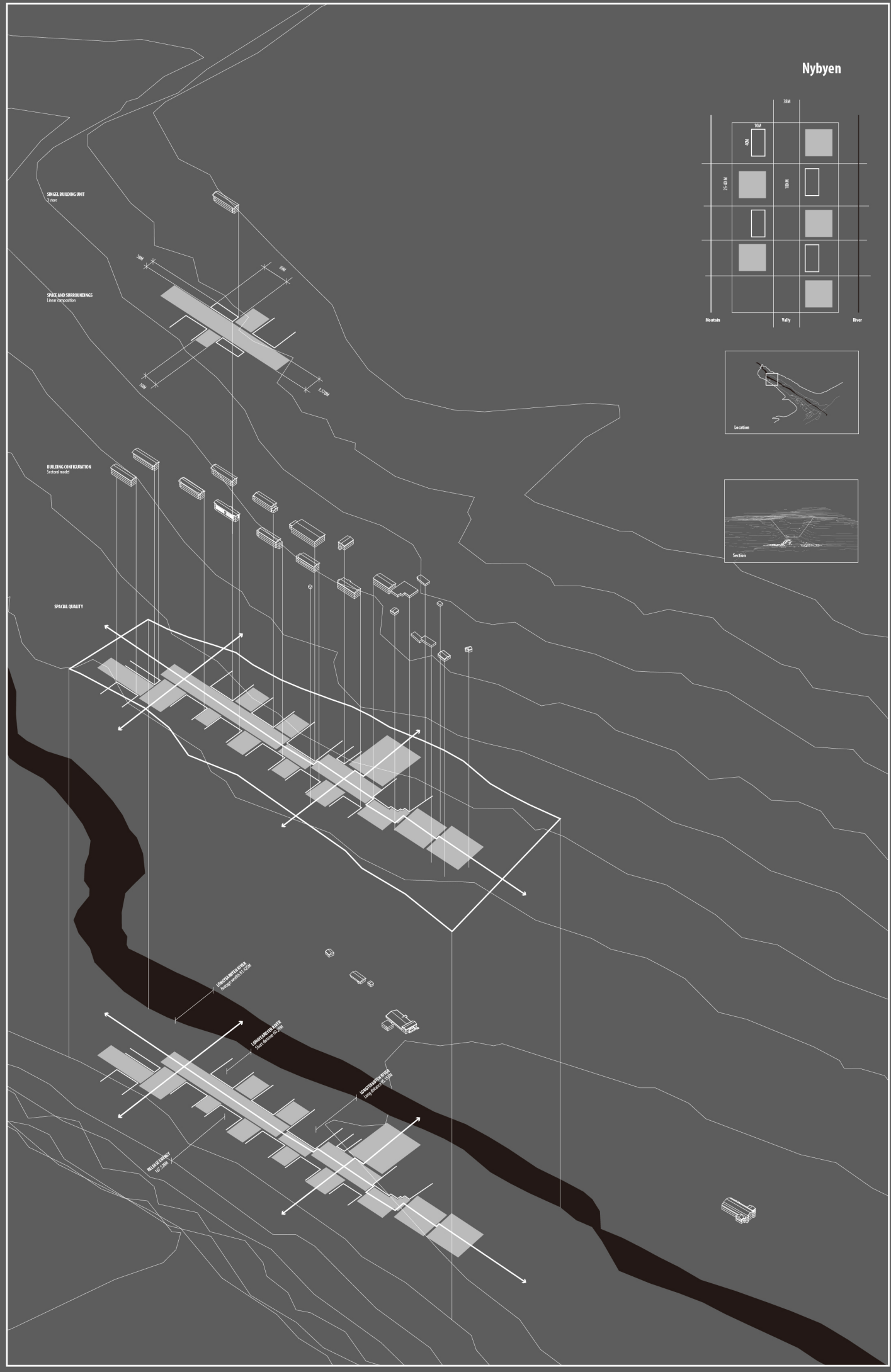

Haugen

Existing urban patterns

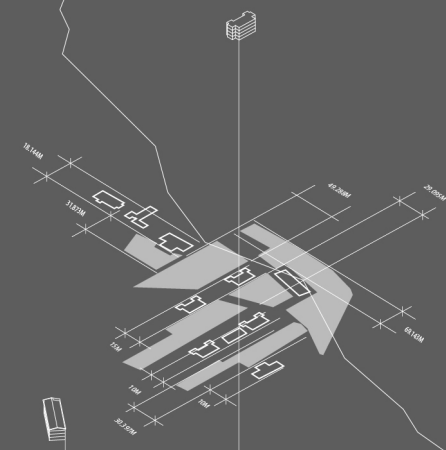
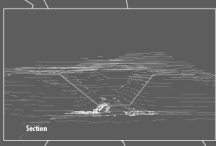
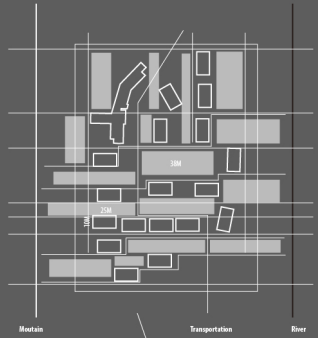

SINGLE BUILDING UNIT
3 store

SPACE AND SUBSEQUENCES
Concrete one road

BUILDING CONFIGURATION
Multiple sub-height

SPECIAL QUALITY

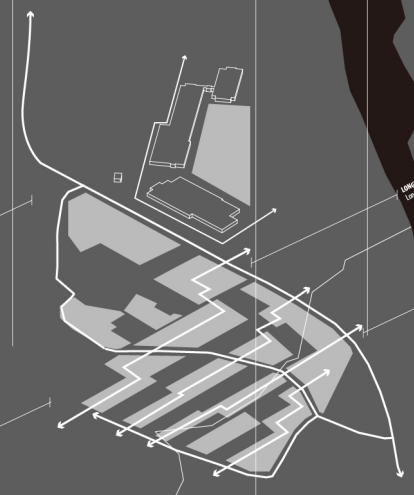
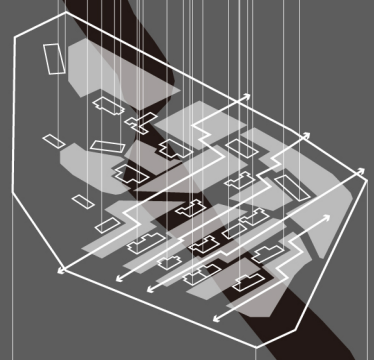

SHARED SPACE
10.00m

SHARED SPACE
10.00m

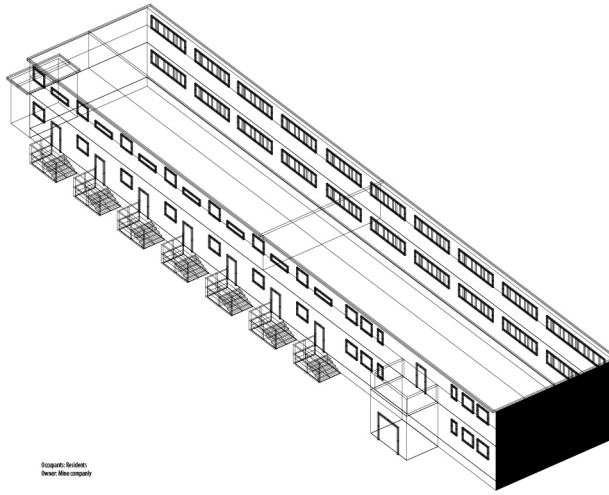

Occupants: Residents
Owner: M&M company

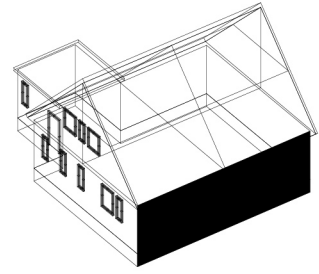

Occupants: Residents
Owner: M&M company

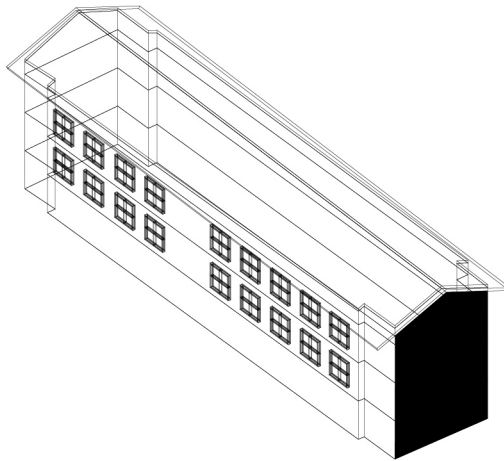

Occupants: Residents
Owner: M&M company

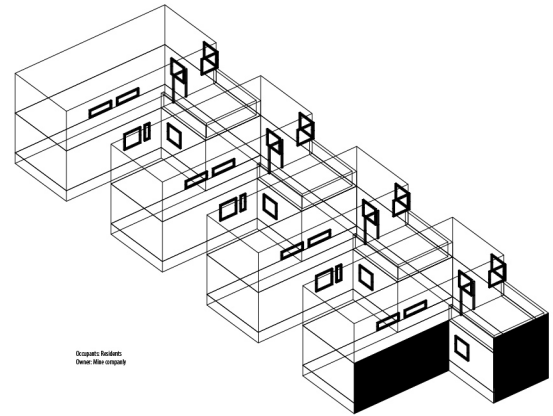

Occupants: Residents
Owner: M&M company

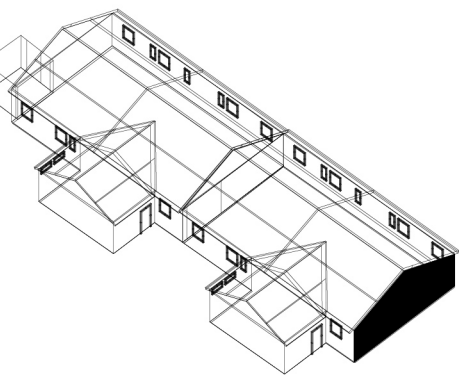

Occupants: Residents
Owner: Micro company

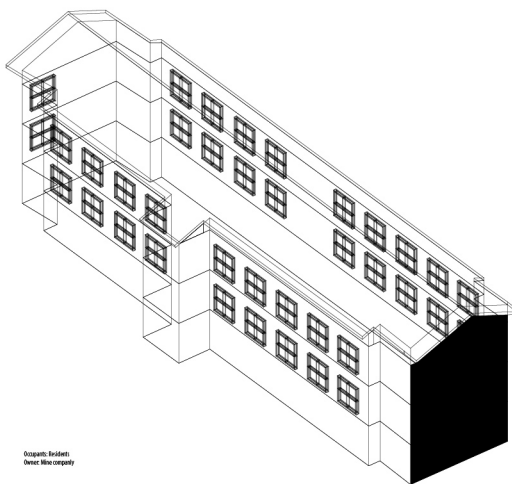

Occupants: Residents
Owner: Micro company

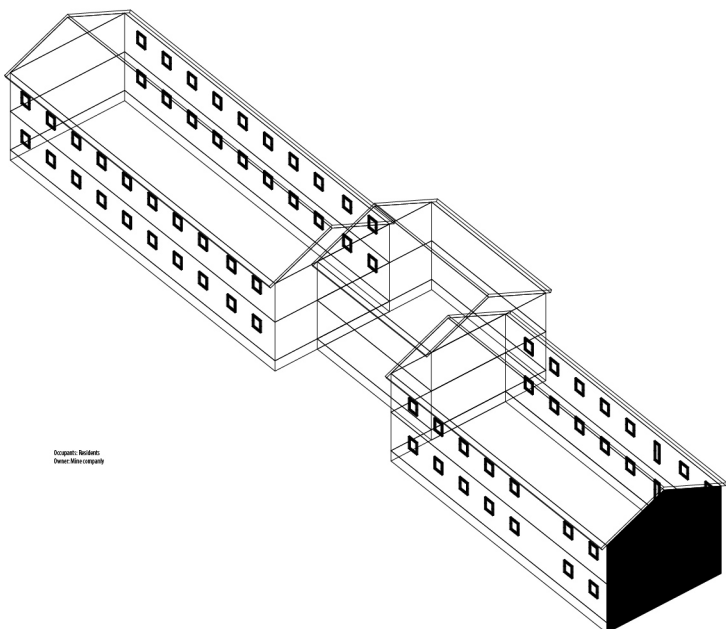

Occupants: Residents
Owner: Micro company

**INSIGHT OF BUILDINGS
REVEALS RESIDENTIAL HOUSING
CRISIS**

**HOUSING UNIT 1
DESIGN FOR DISASSEMBLY**

SPATIAL FORM

VACANT STRUCTURE

REUSE ROOF

REUSE ROOF

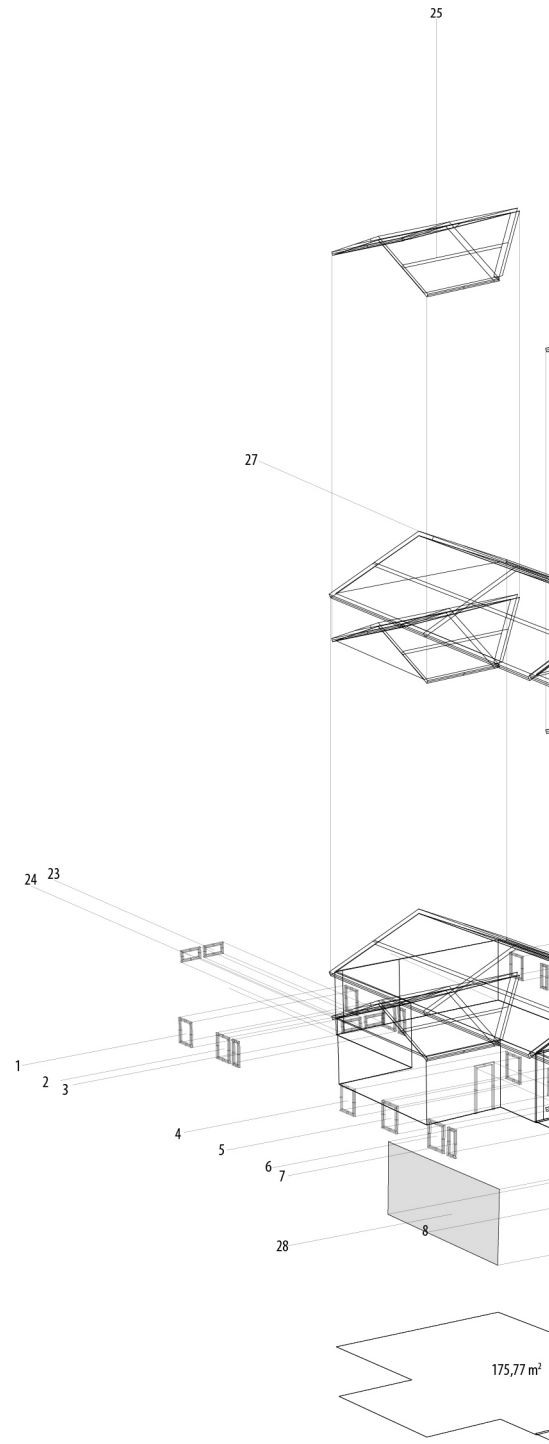

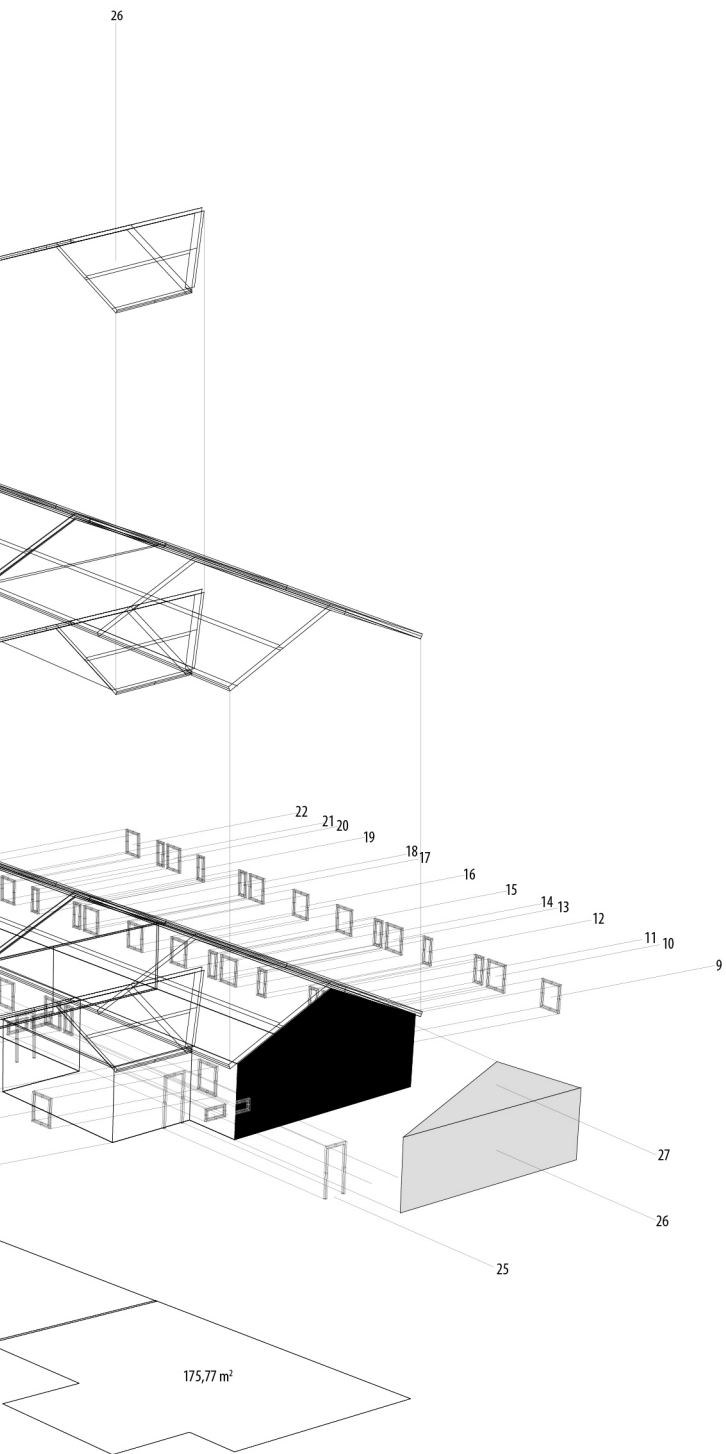



*Study model of the
mitigation of slope
near runway*



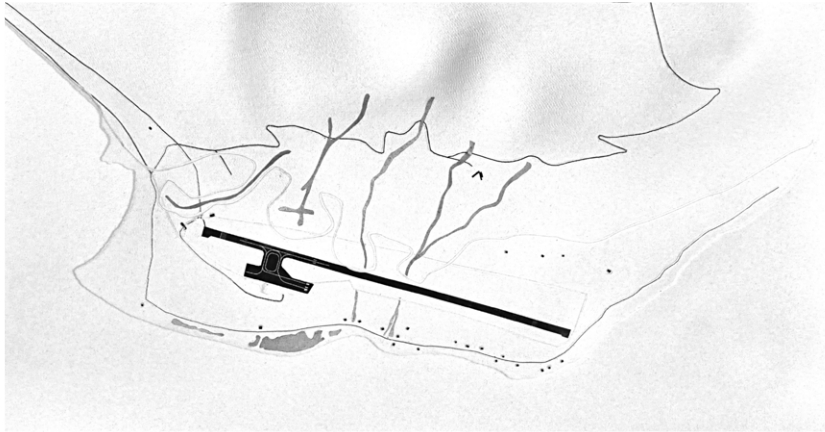

*Existing situation of airport /
Risks interface*

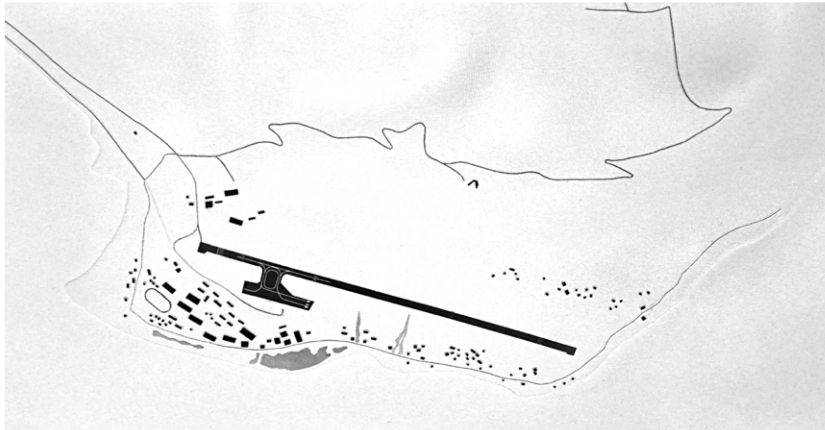

CONCENTRAED

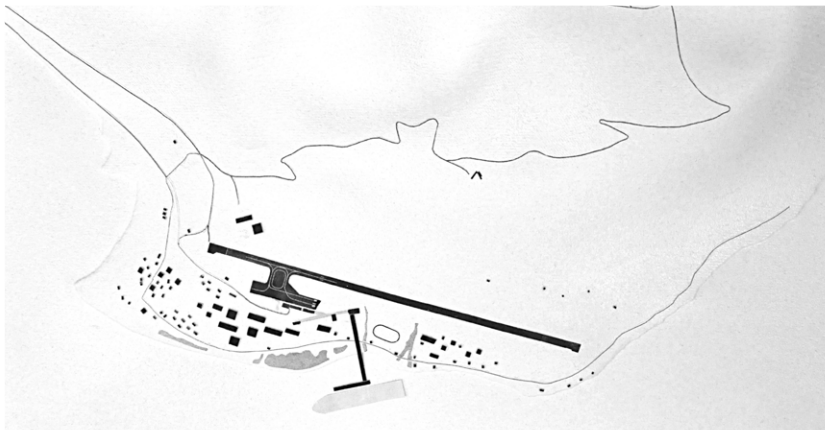

GRID

**The processing of
airport city**
Study model
:testing different
configurations.

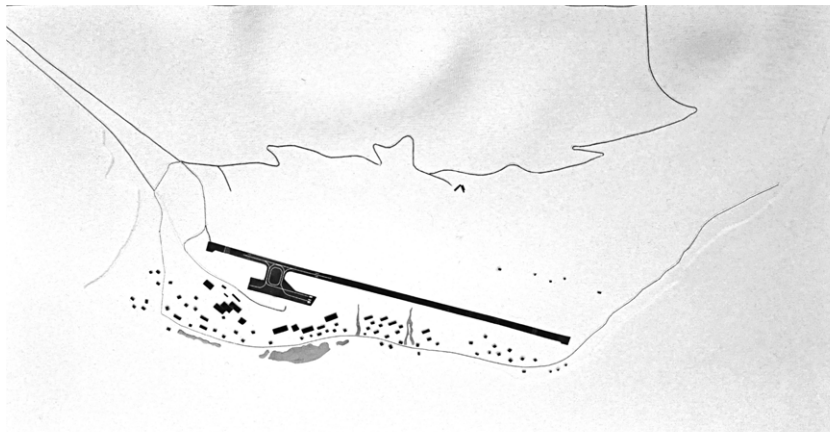

RADIATE

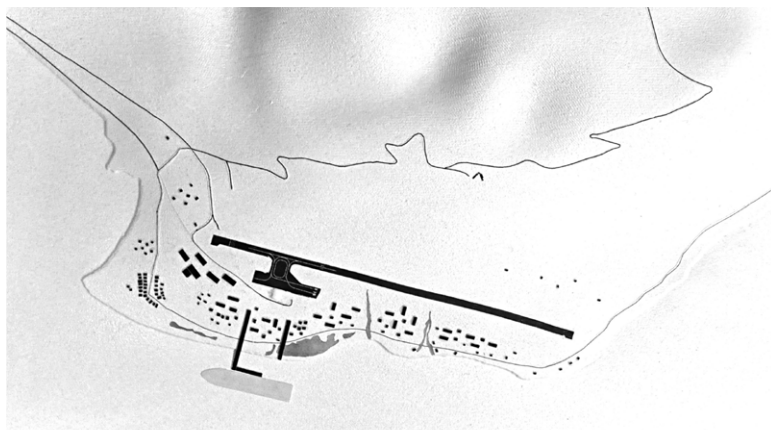

CLUSTER

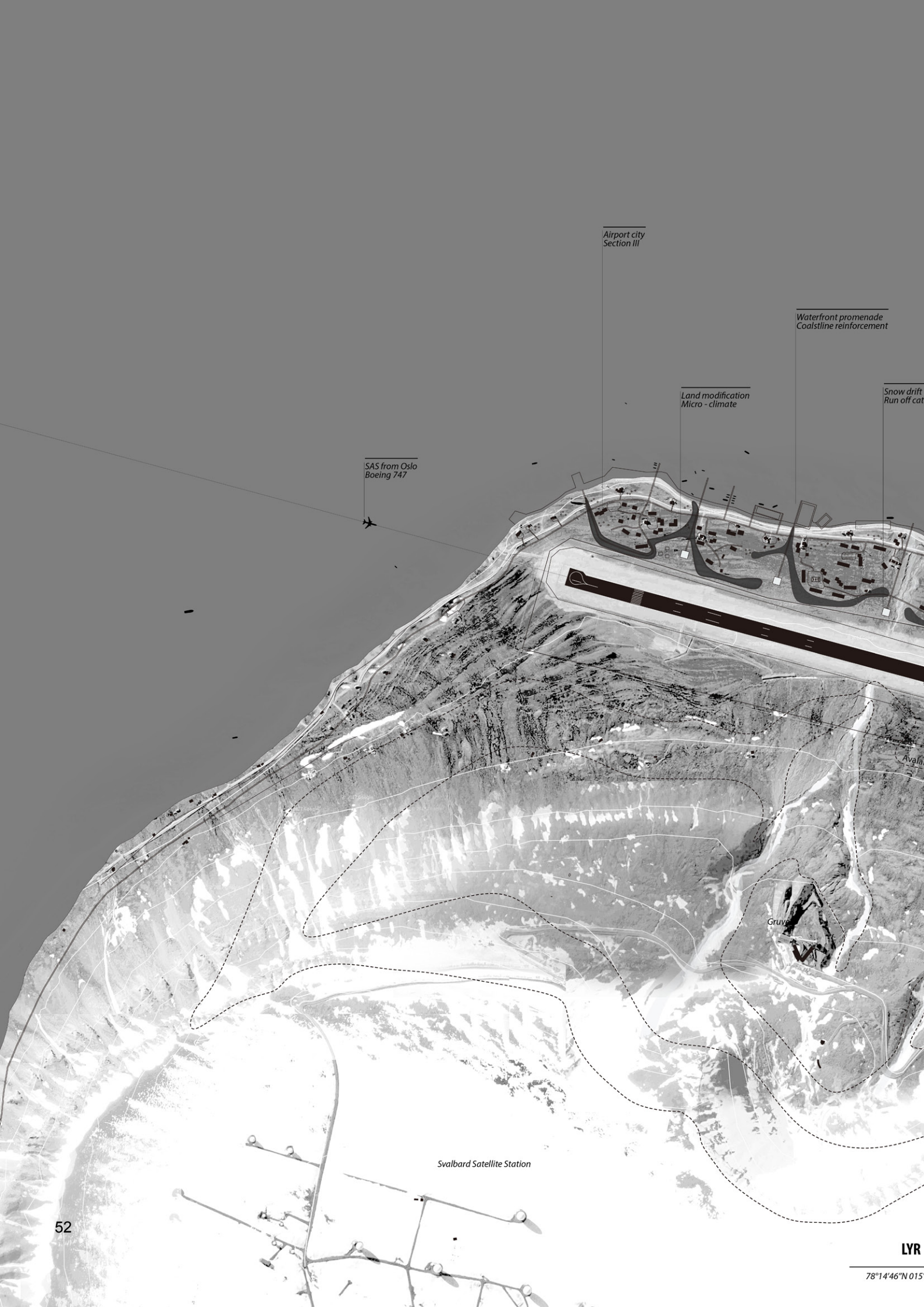

Airport city
Section III

Waterfront promenade
Coalstline reinforcement

Land modification
Micro - climate

Snow drift
Run off cat

SAS from Oslo
Boeing 747



Svalbard Satellite Station

Gruve

Avala

Terminal - Harbour city
Section II

Condence airport city
Section I

chment

Base camp
Temporary

Existing Industrial

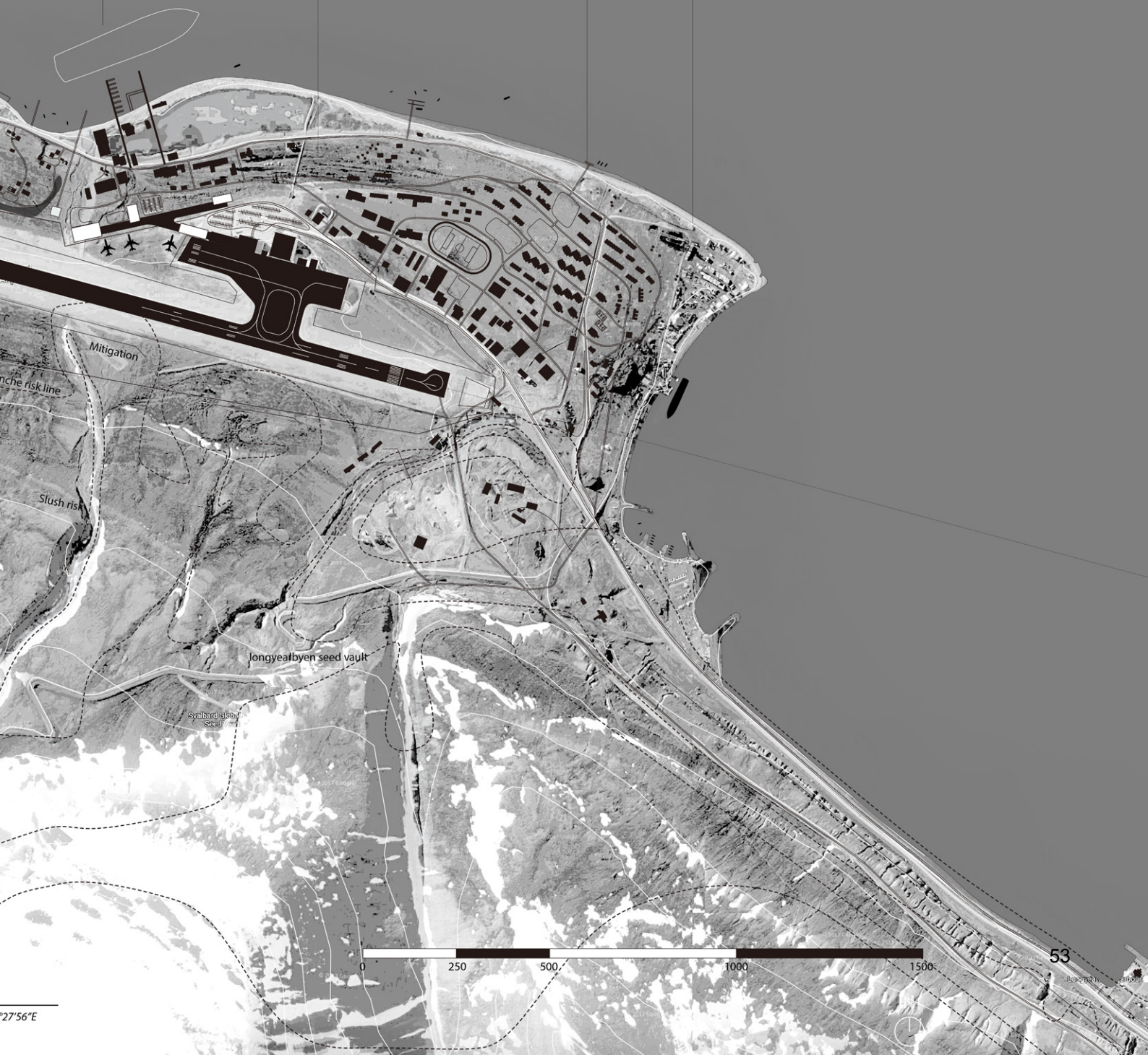

27°56'E

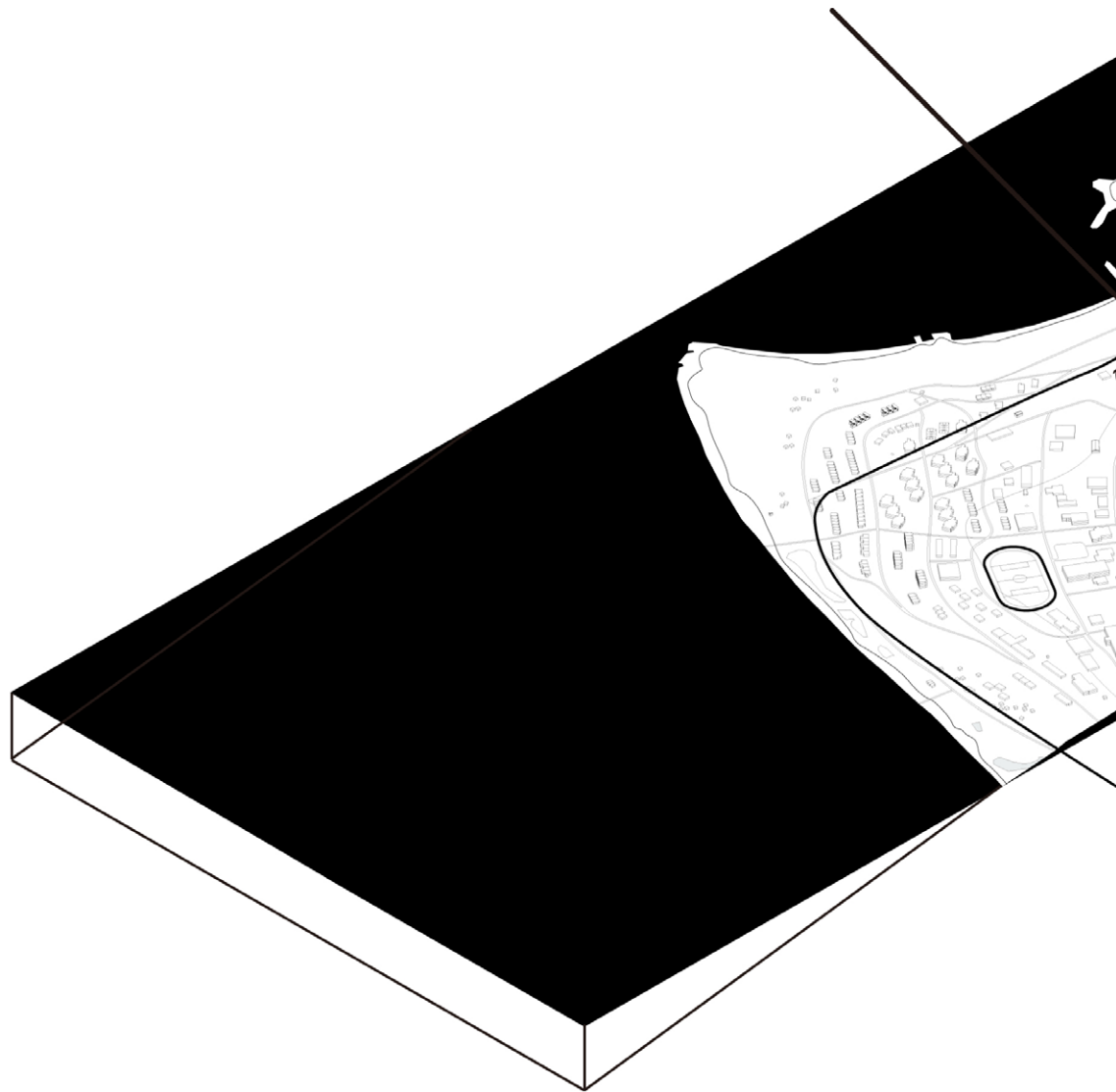

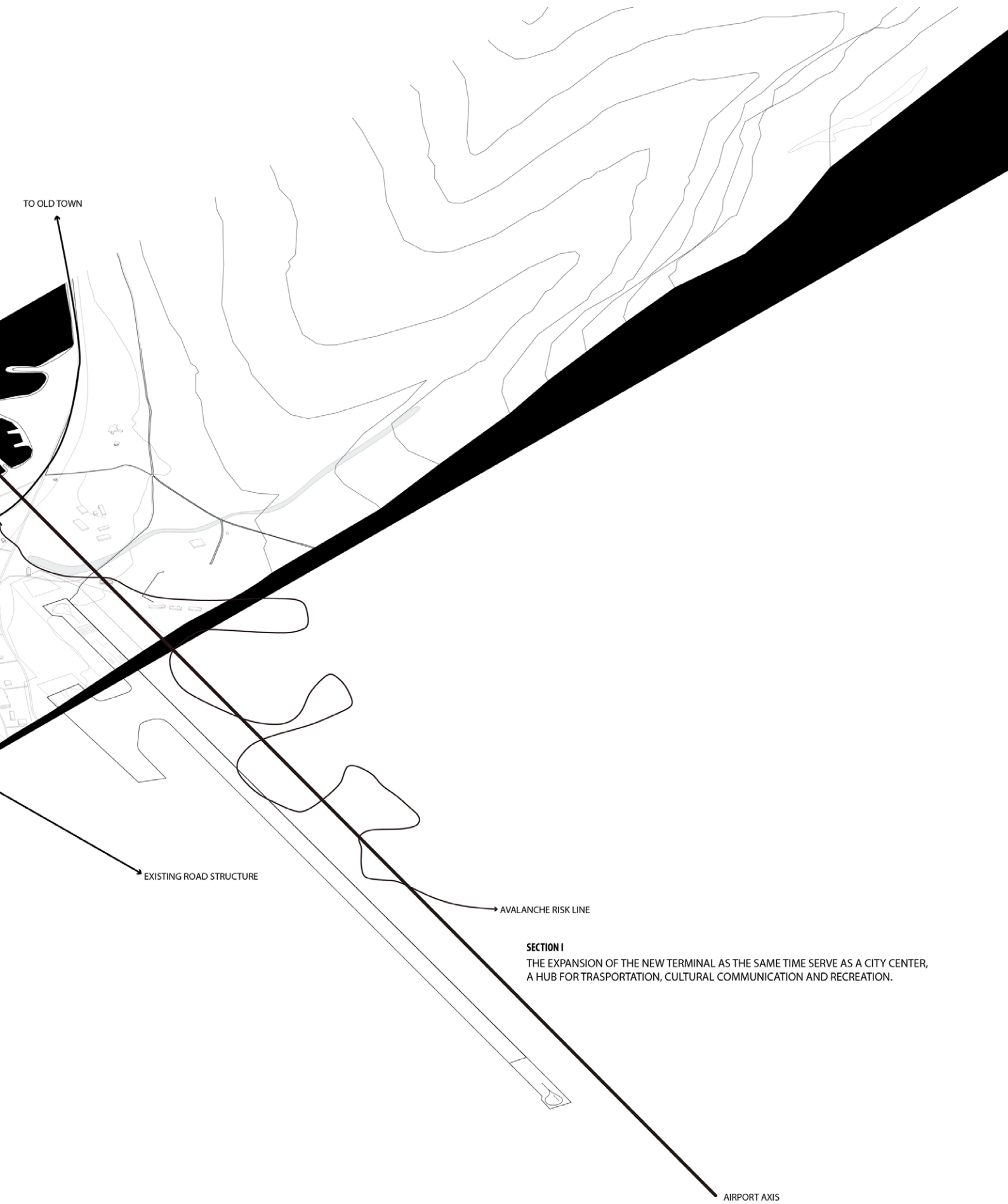

TO OLD TOWN

EXISTING ROAD STRUCTURE

AVALANCHE RISK LINE

SECTION I

THE EXPANSION OF THE NEW TERMINAL AS THE SAME TIME SERVE AS A CITY CENTER, A HUB FOR TRASPORTATION, CULTURAL COMMUNICATION AND RECREATION.

AIRPORT AXIS

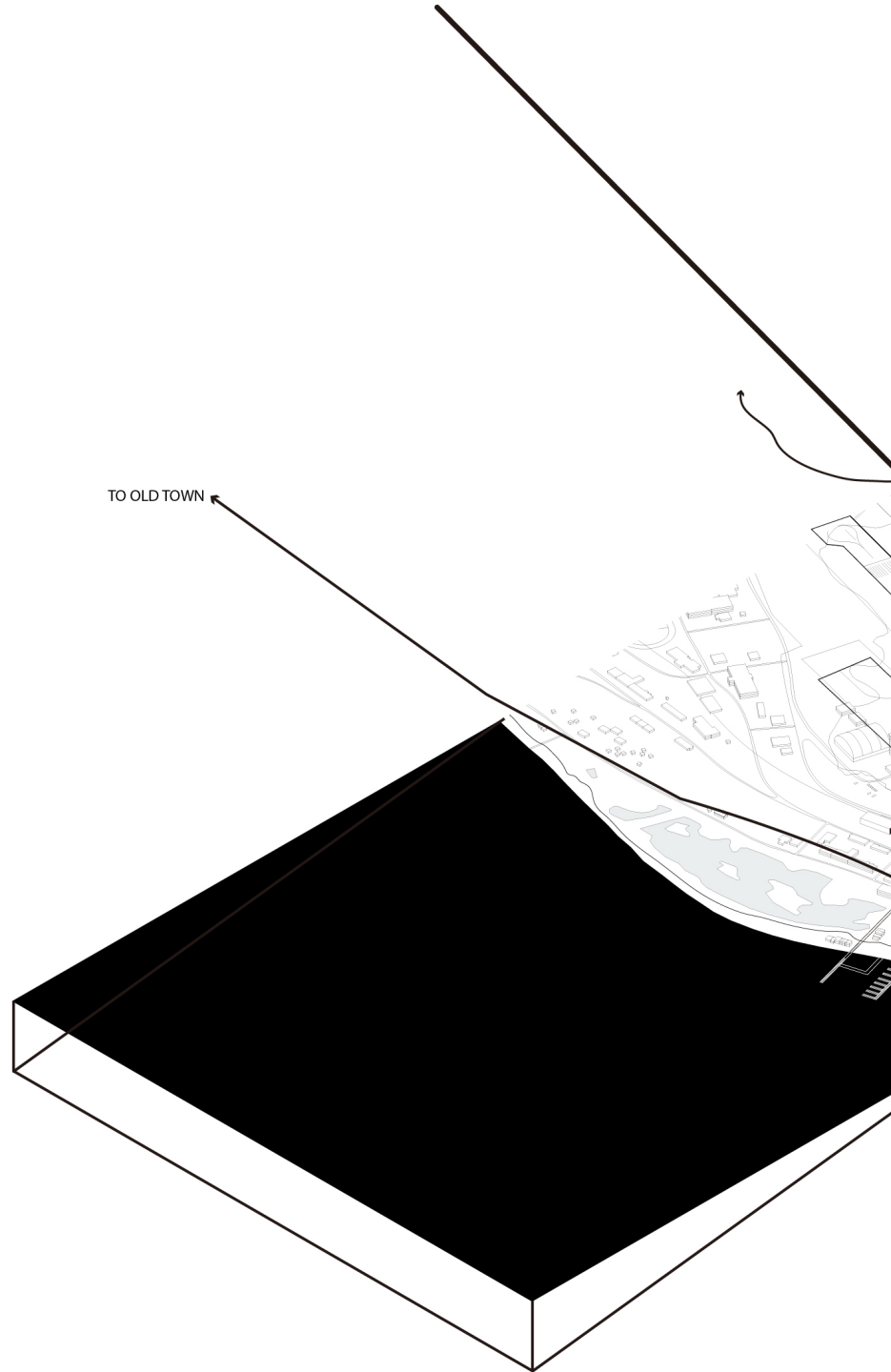

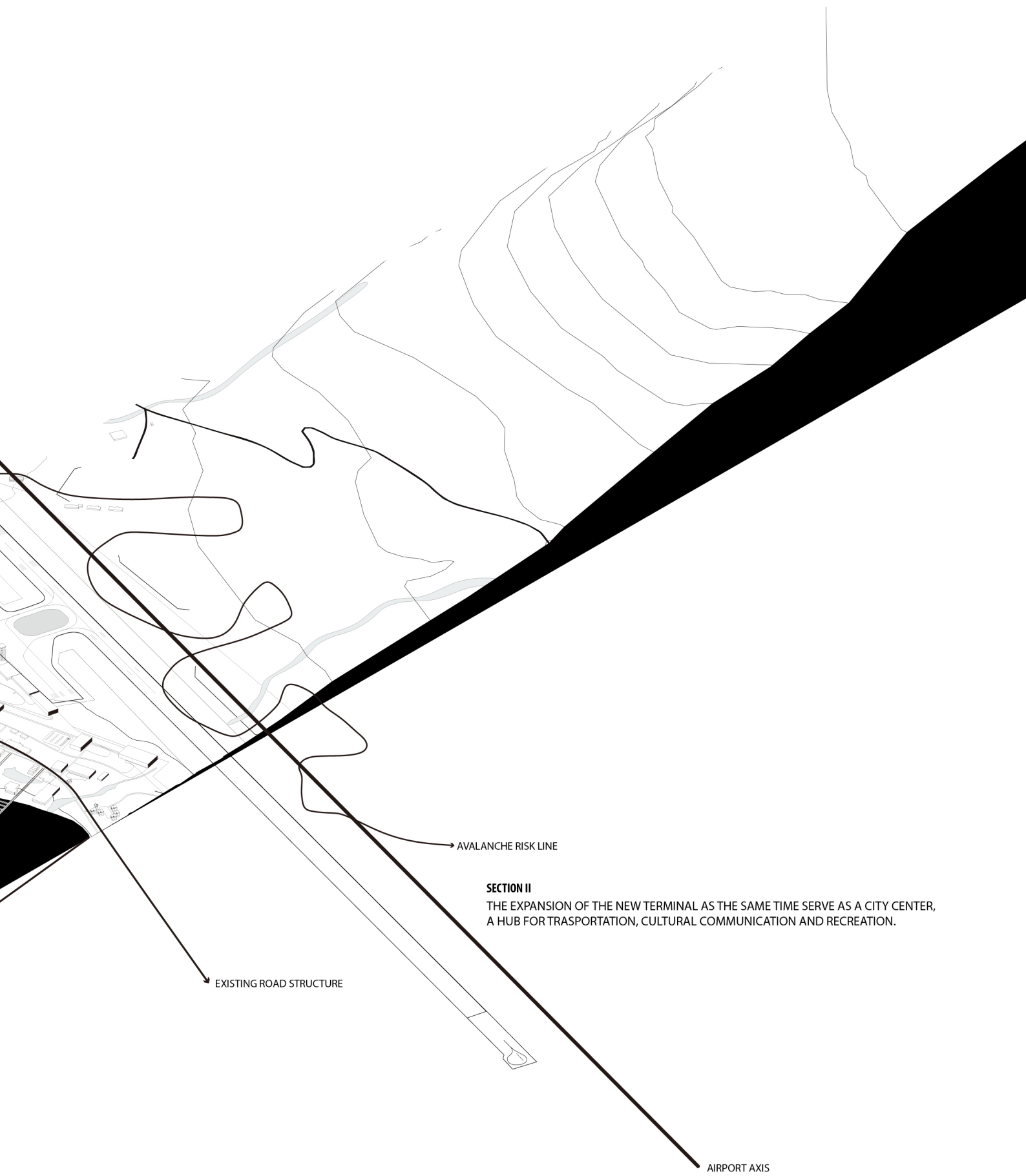

→ AVALANCHE RISK LINE

SECTION II

THE EXPANSION OF THE NEW TERMINAL AS THE SAME TIME SERVE AS A CITY CENTER,
A HUB FOR TRASPORTATION, CULTURAL COMMUNICATION AND RECREATION.

→ EXISTING ROAD STRUCTURE

→ AIRPORT AXIS

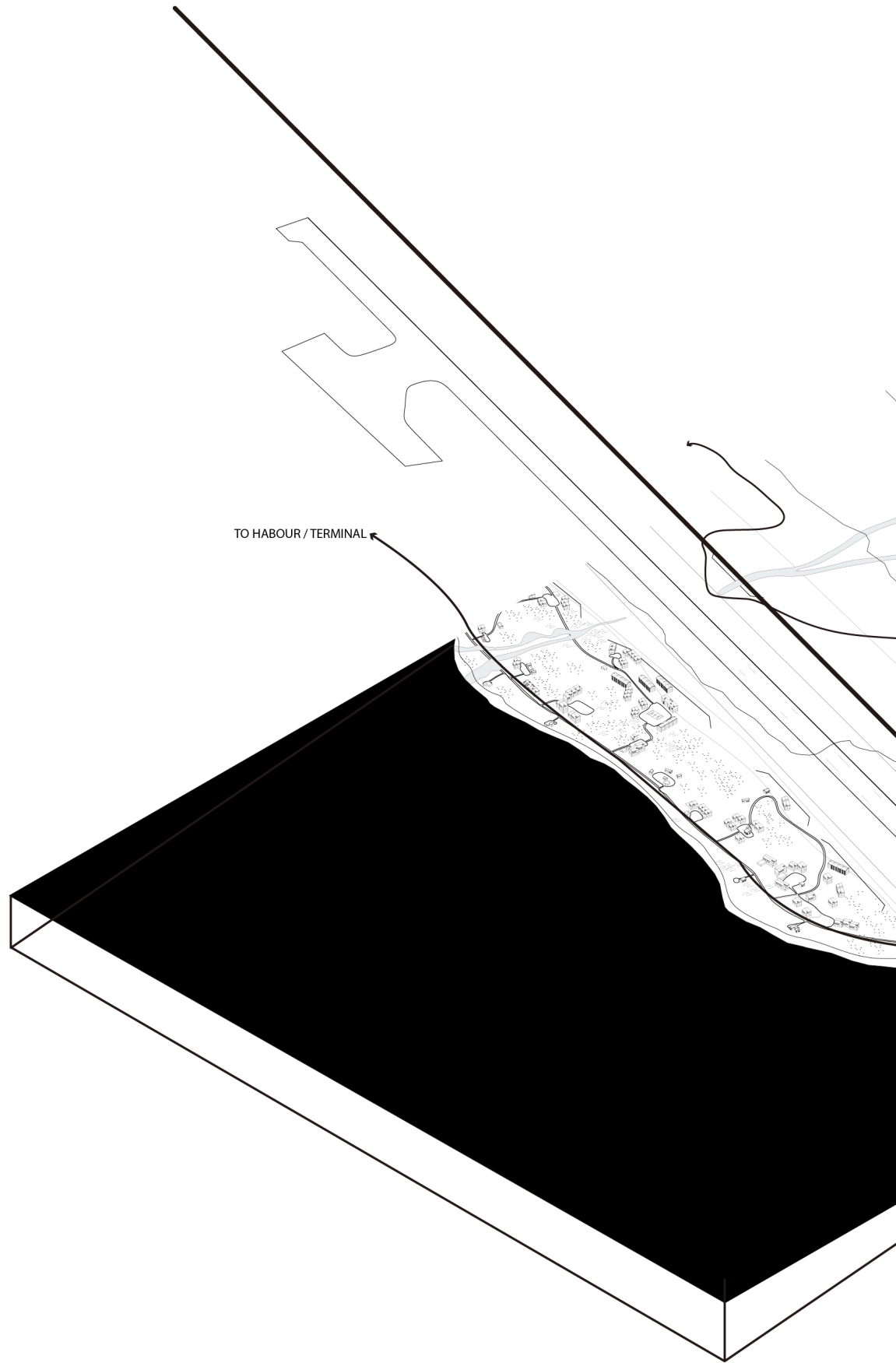

TO HARBOUR / TERMINAL

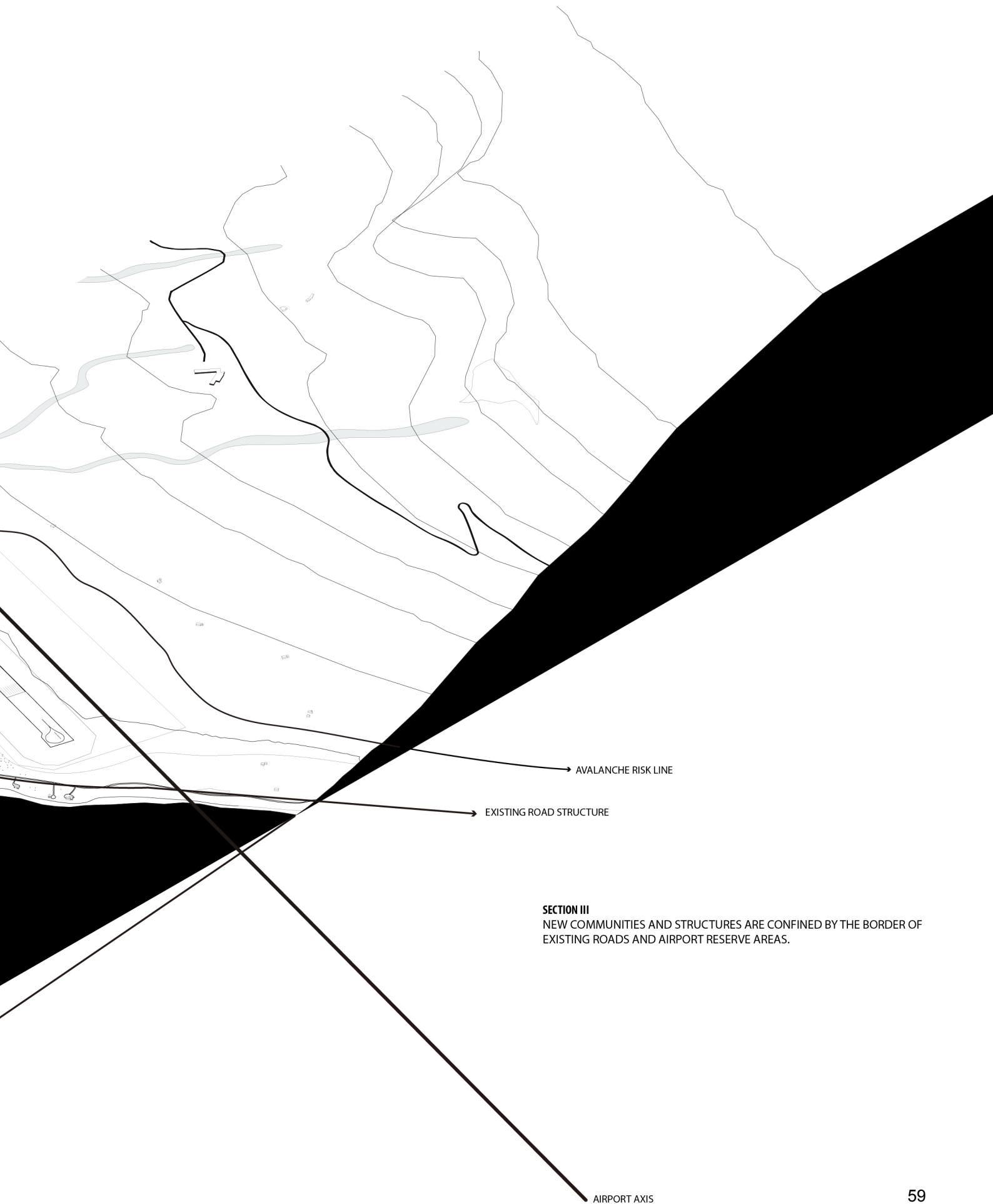

AVALANCHE RISK LINE

EXISTING ROAD STRUCTURE

SECTION III
NEW COMMUNITIES AND STRUCTURES ARE CONFINED BY THE BORDER OF
EXISTING ROADS AND AIRPORT RESERVE AREAS.

AIRPORT AXIS

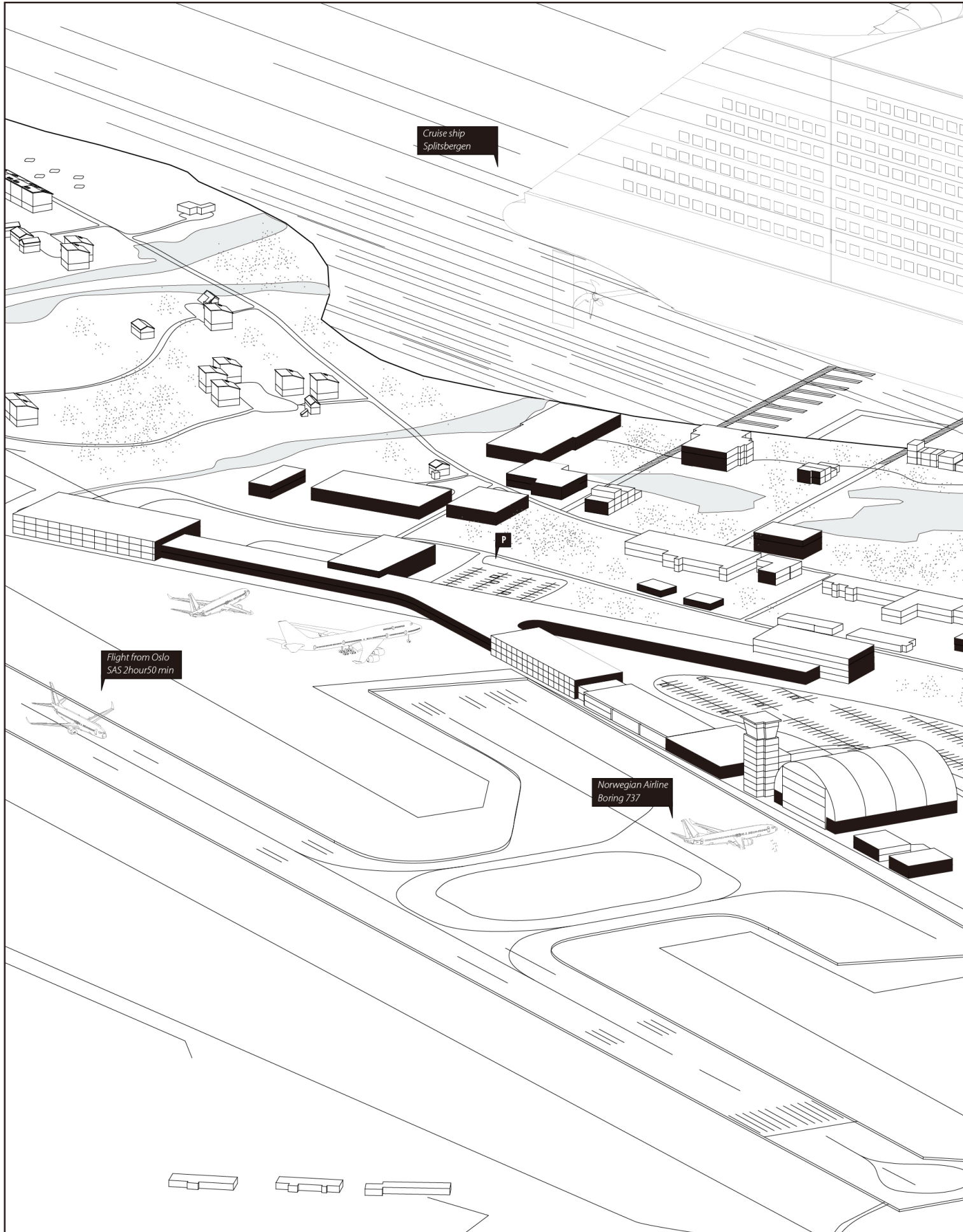

Cruise ship
Splitsbergen

Flight from Oslo
SAS 2hour50 min

Norwegian Airline
Boring 737

