

Laboratory Building at Blindern



Sarah Rønning Hansen
Supervisor: Beate Hølmekakk



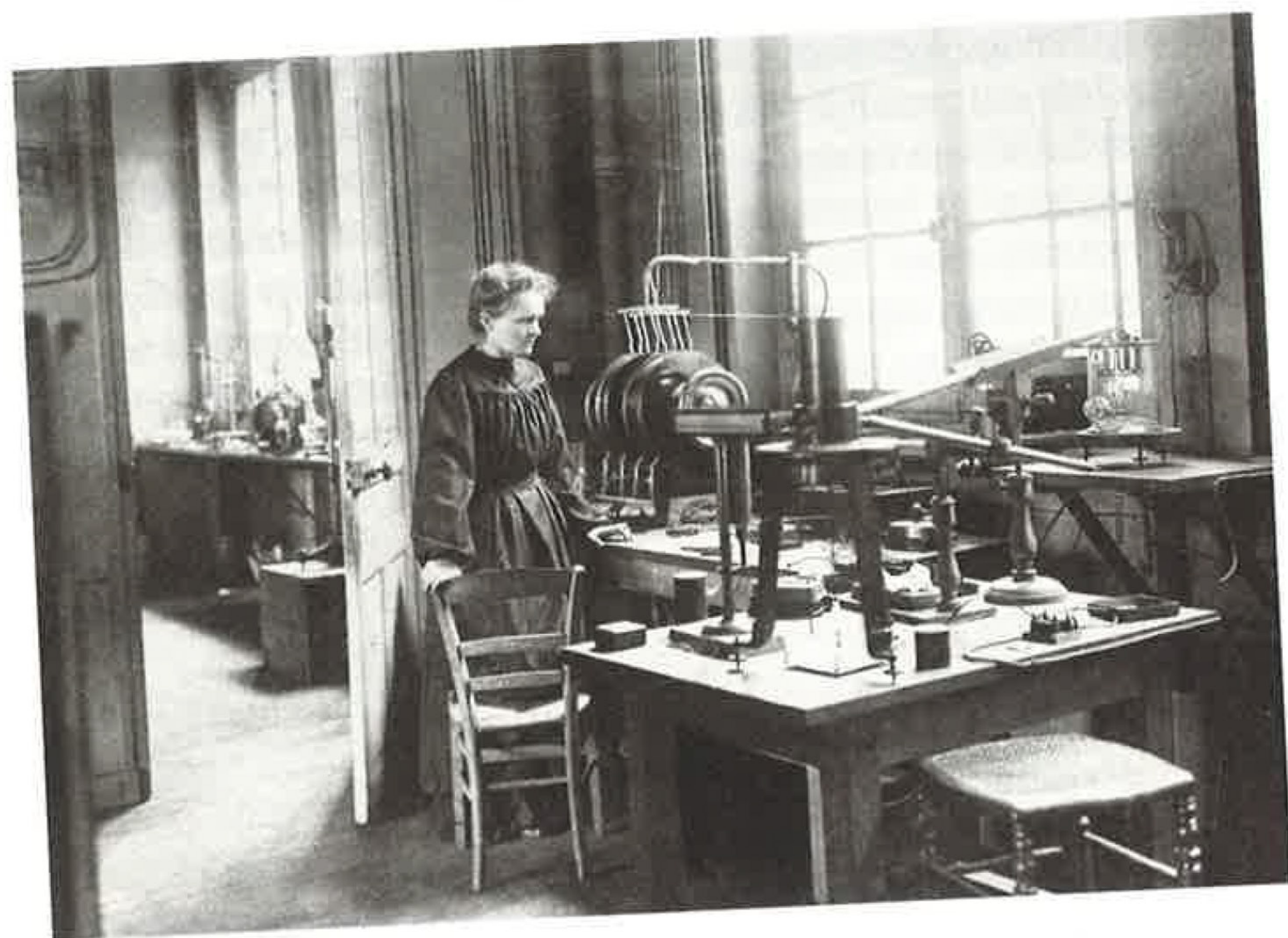

Fig. 3.8:
Marie Curie (1867-1934) in her Laboratory in the Sorbonne, Paris, 1911.
Photo © The LIFE Picture Collection / Getty Images.

... change for aesthetic

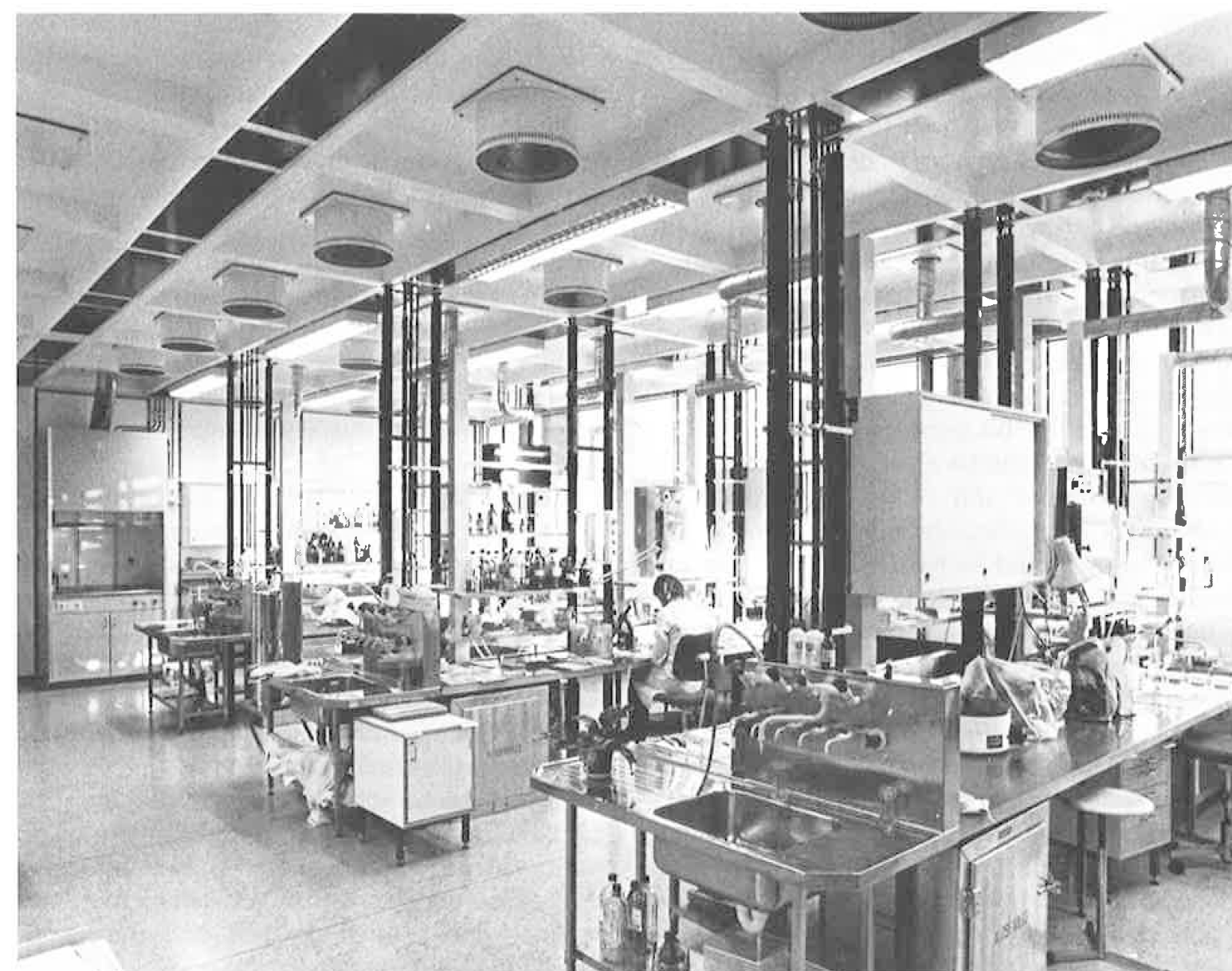

Figure 1.6 Typical lab at Ullèval Hospital.

field Foundation,* and time has shown that the is derived which is a measure of most laboratory

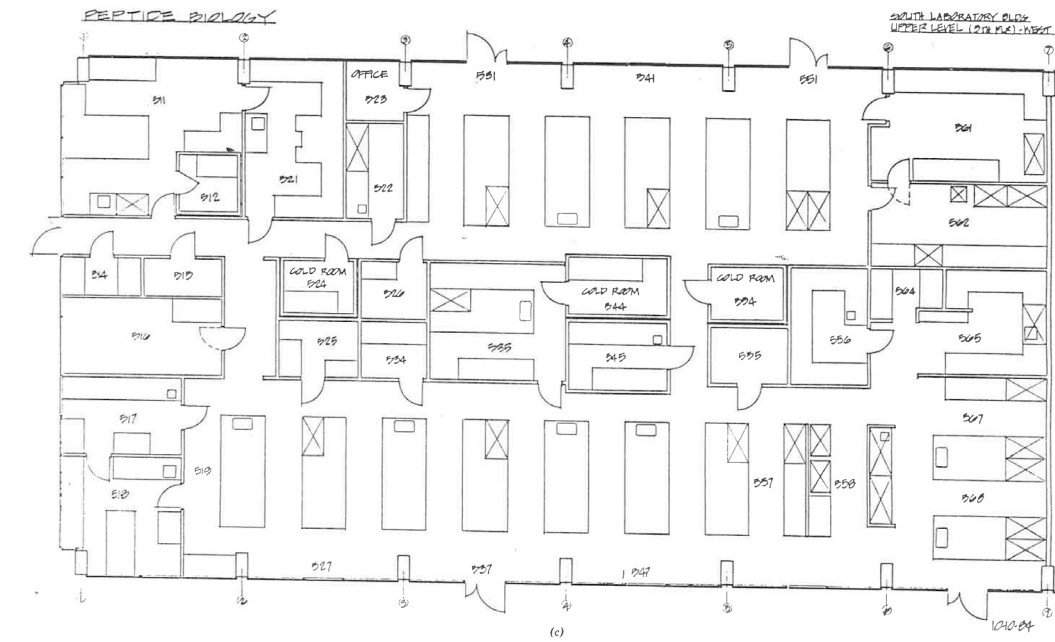
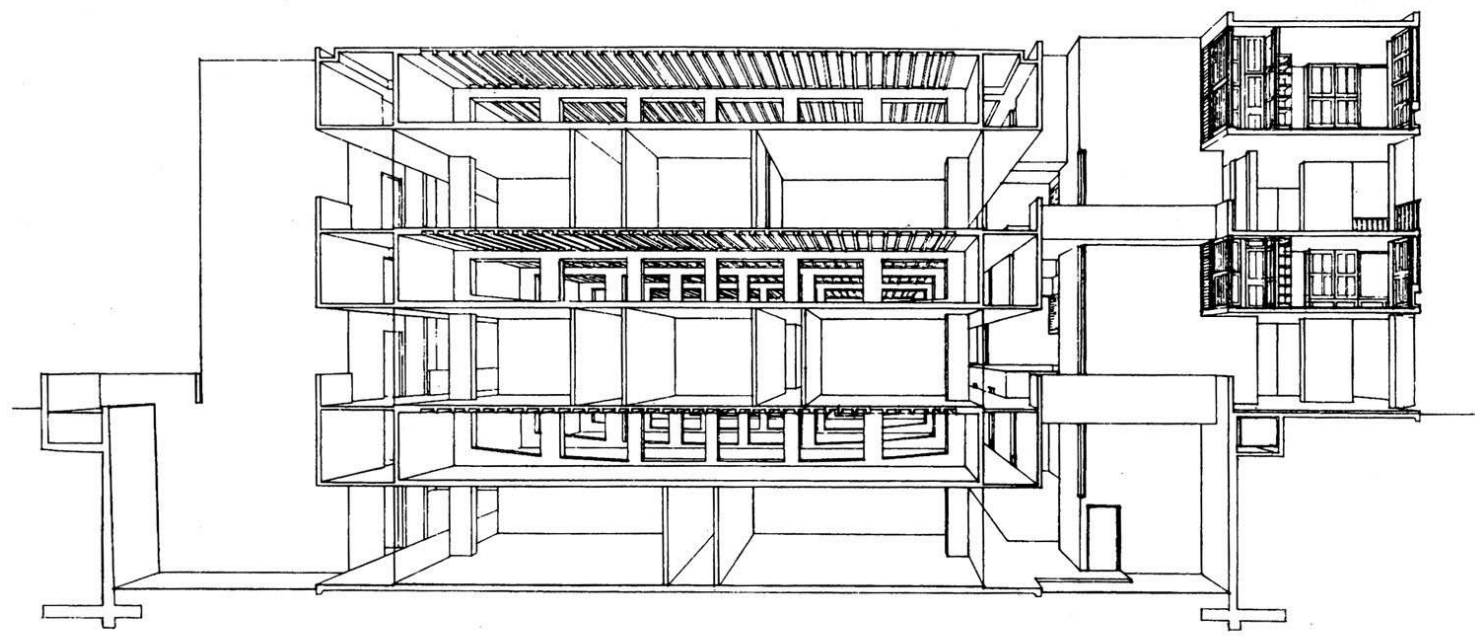
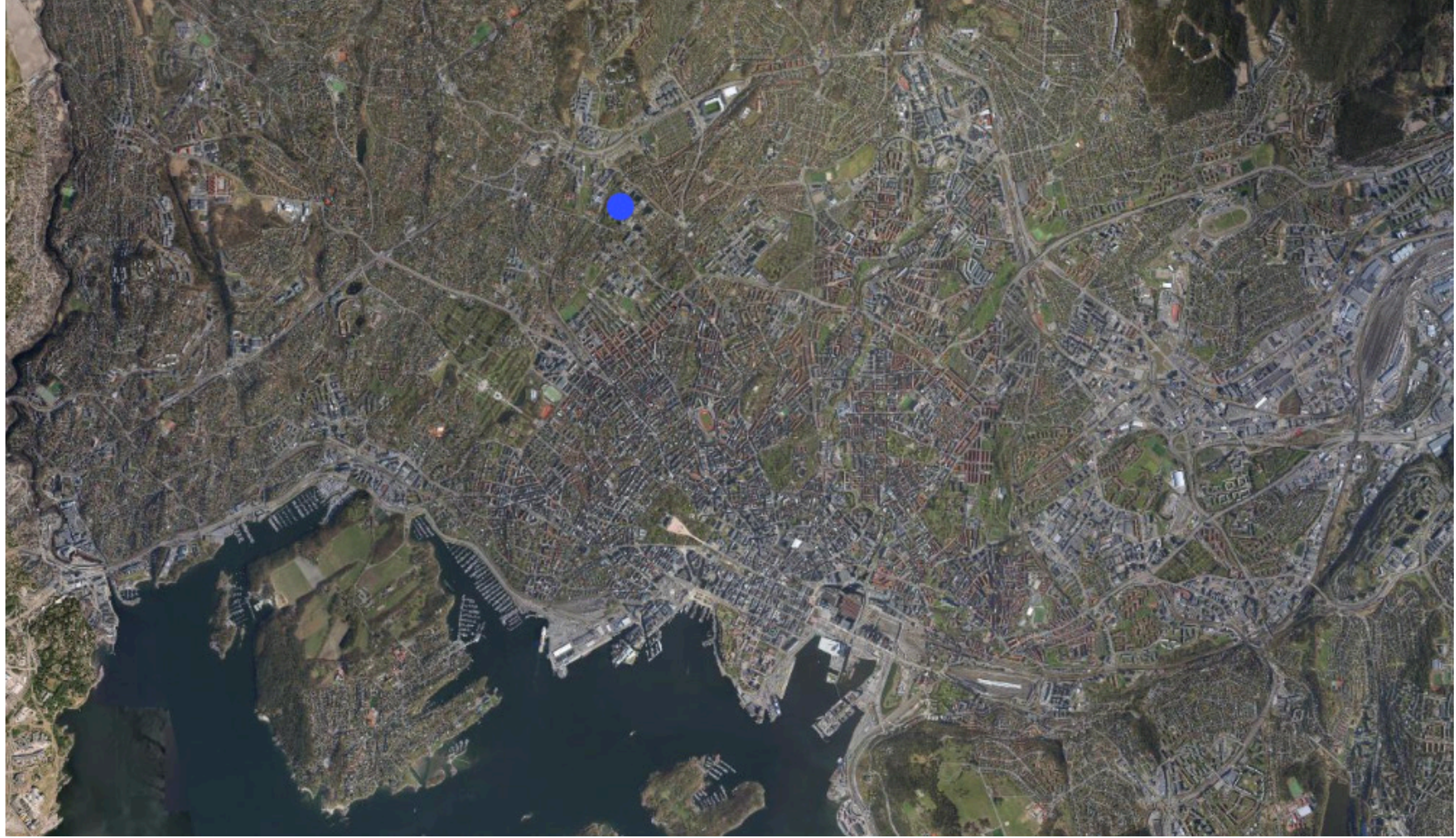
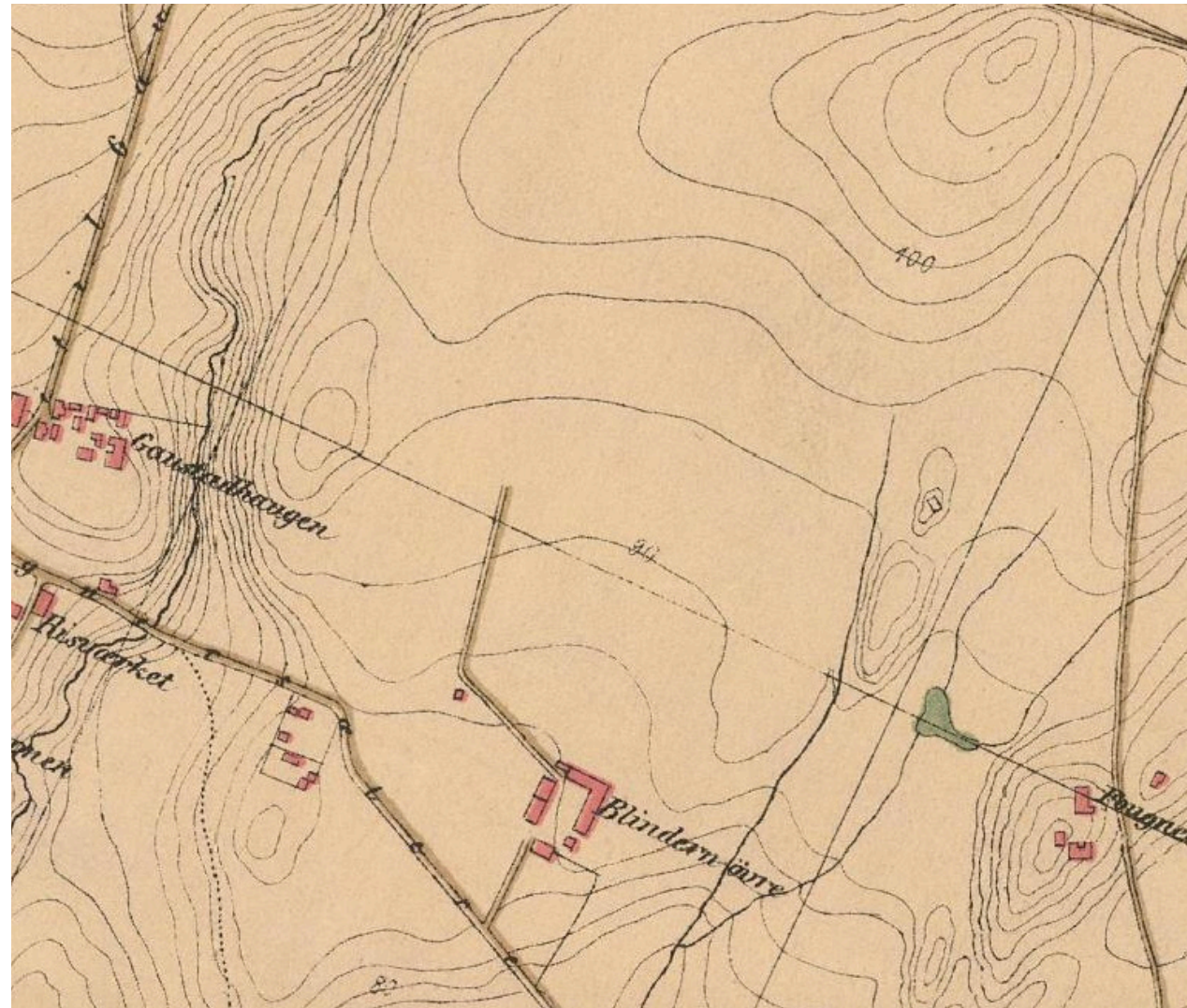

Figure 1.4c Plan of the South Laboratory Building, upper level—west. (Courtesy Salk Institute.)







1881

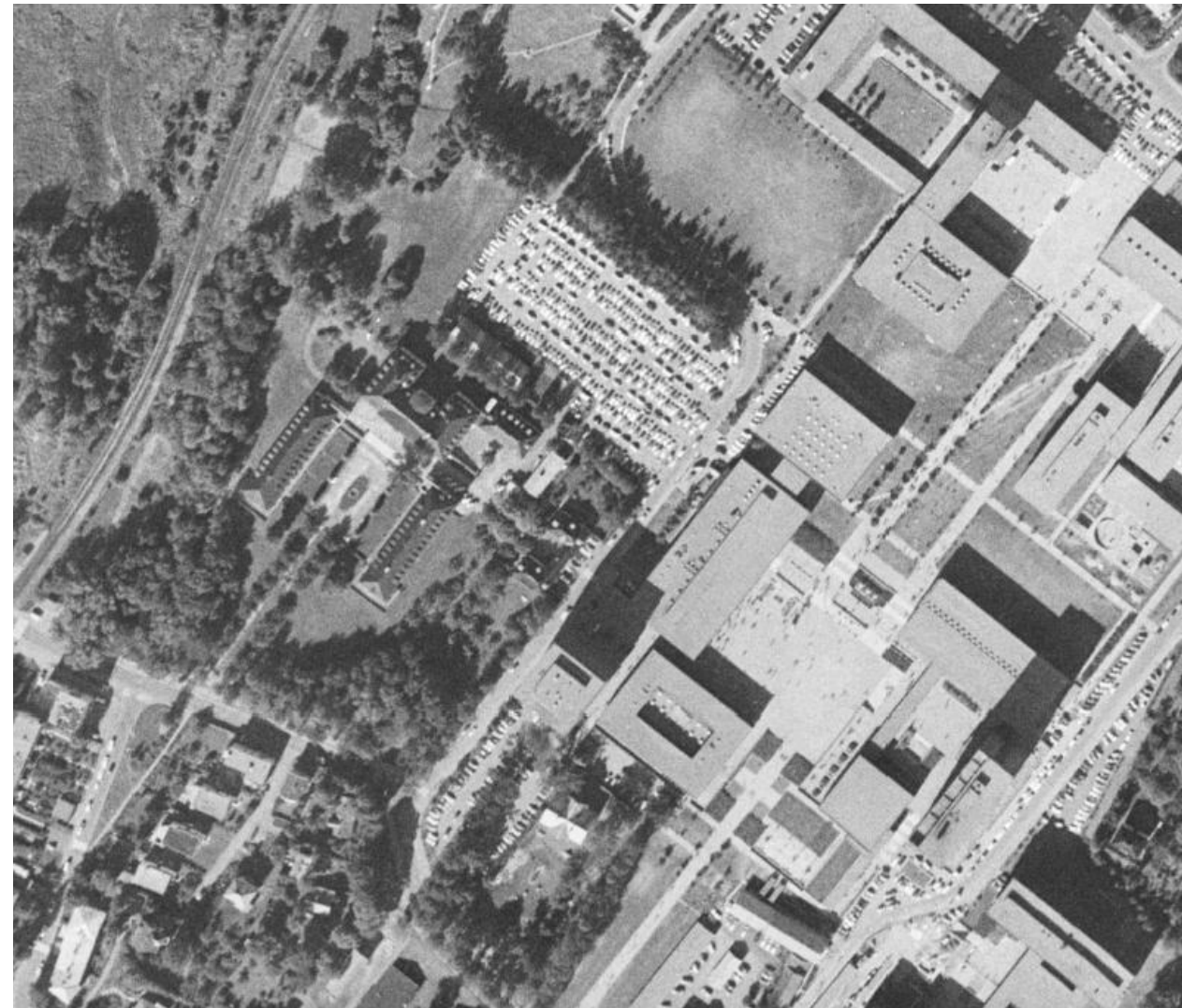

1971



now

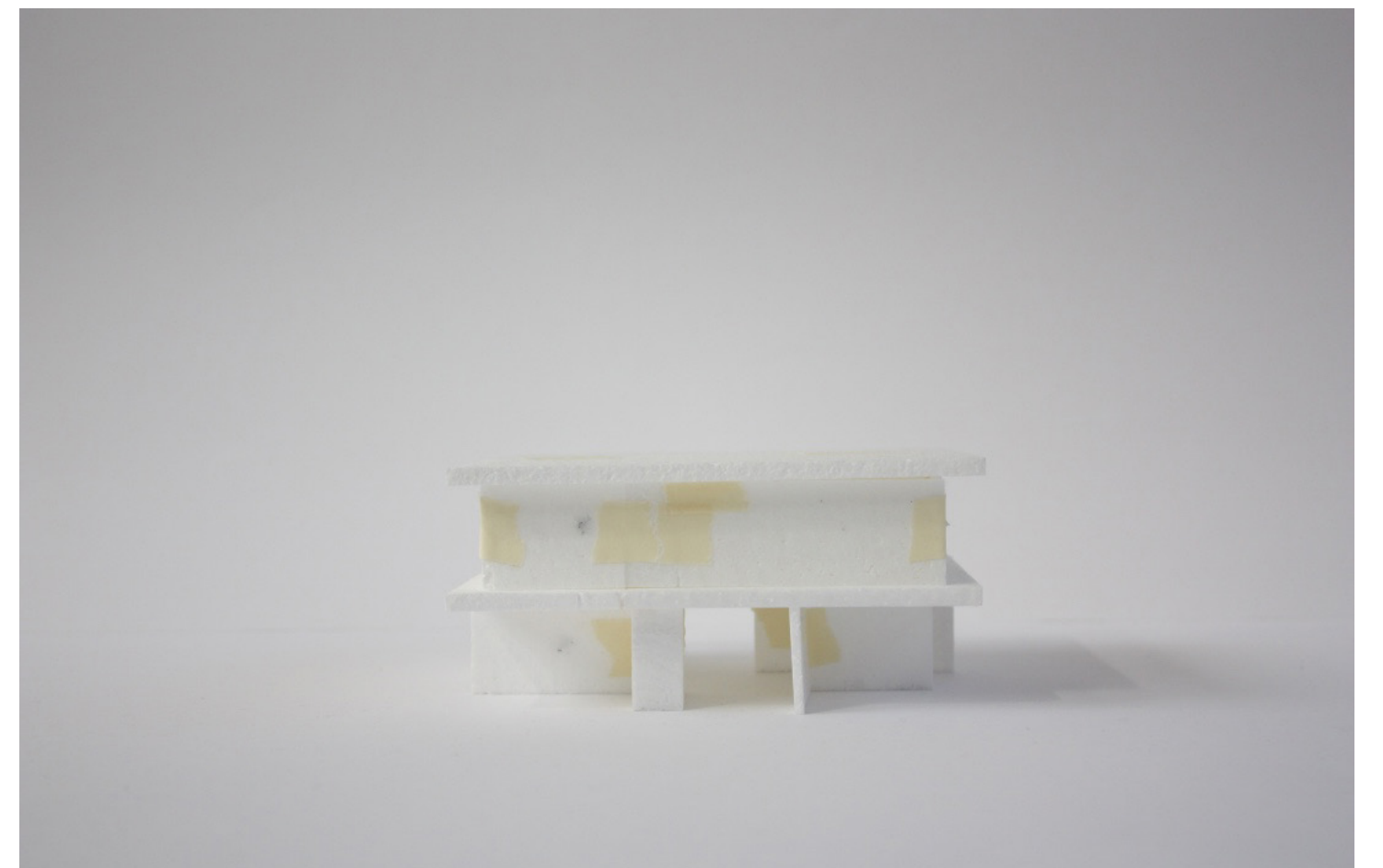

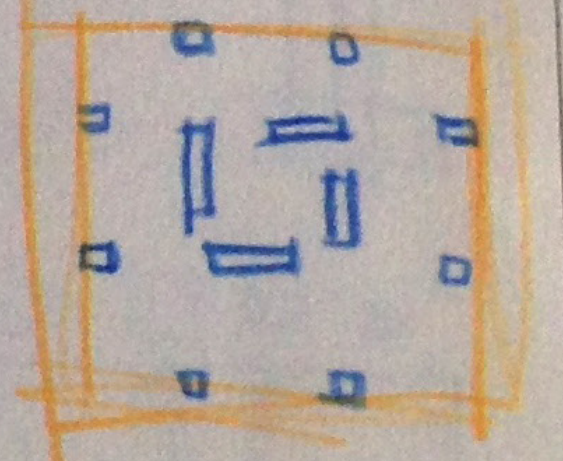
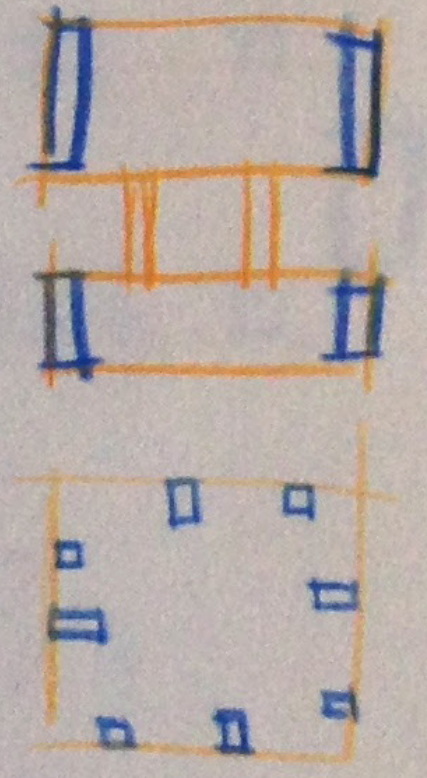
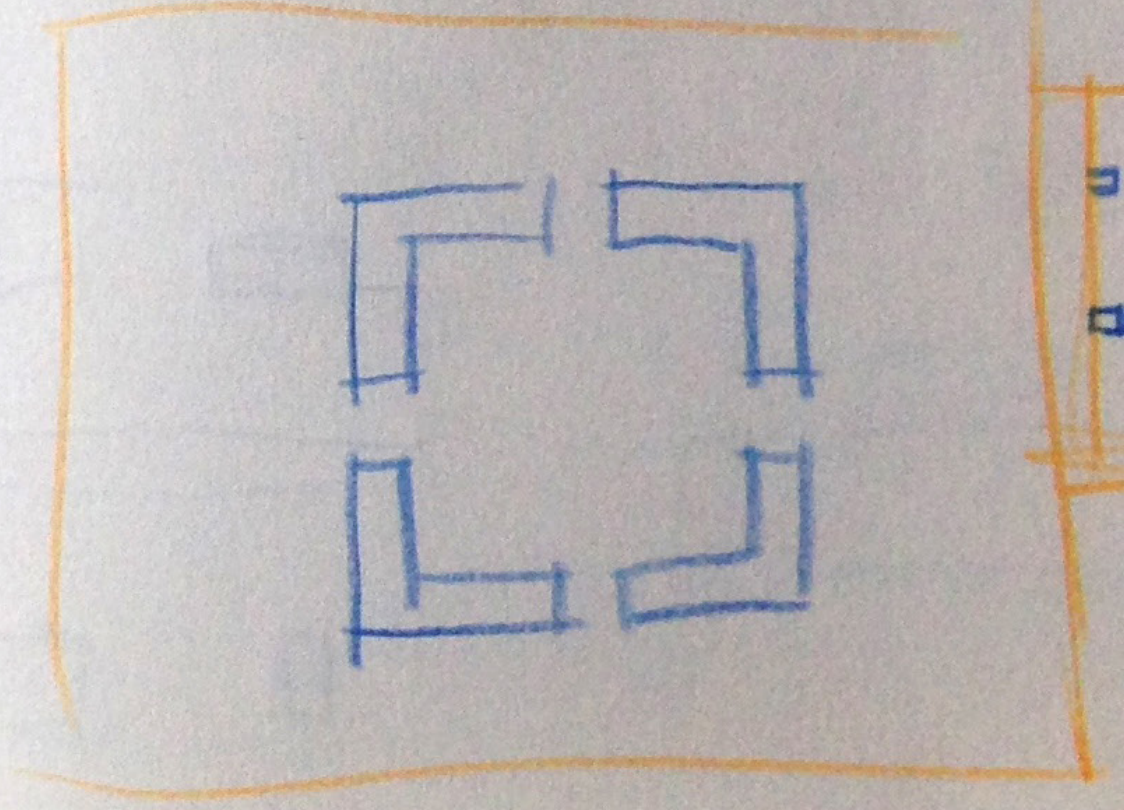
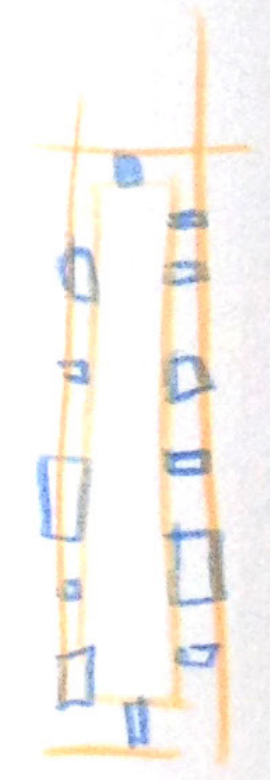
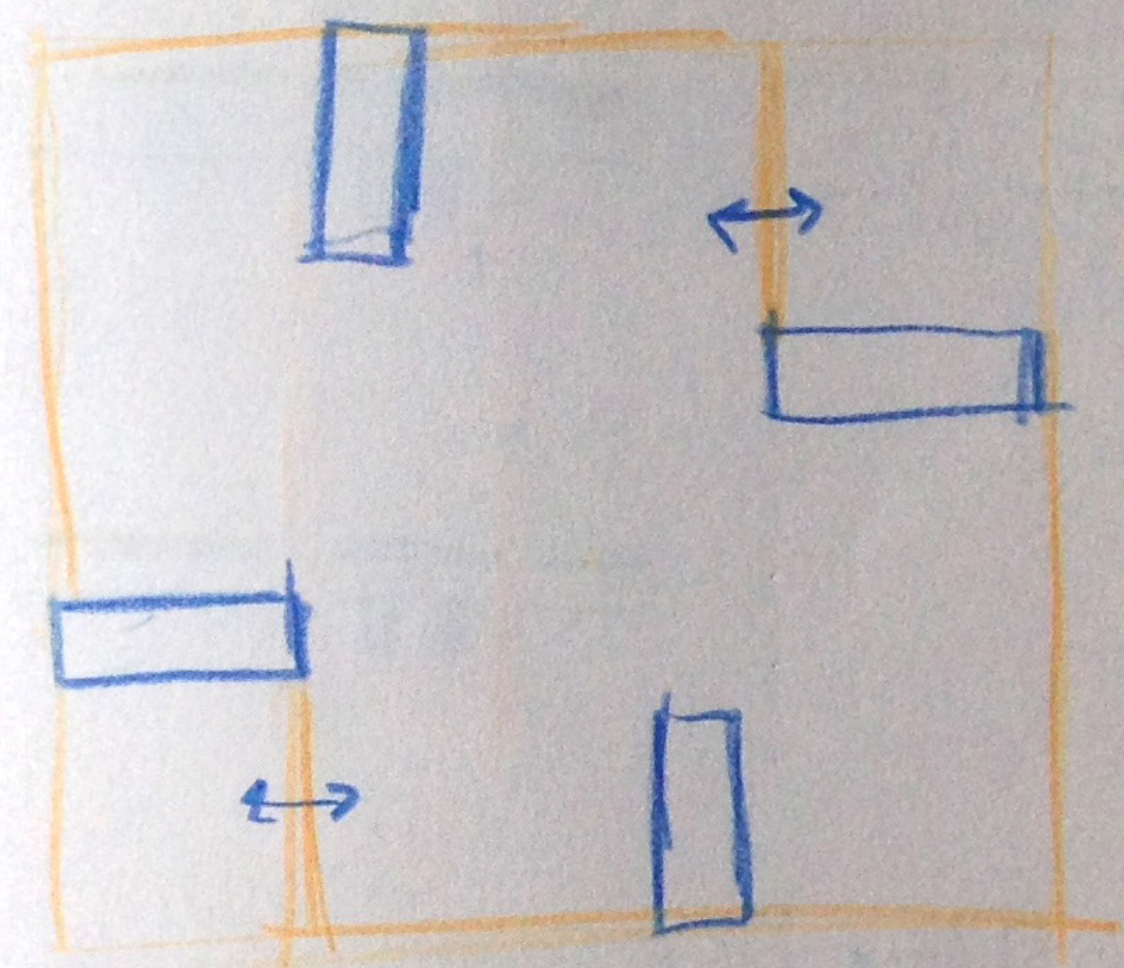
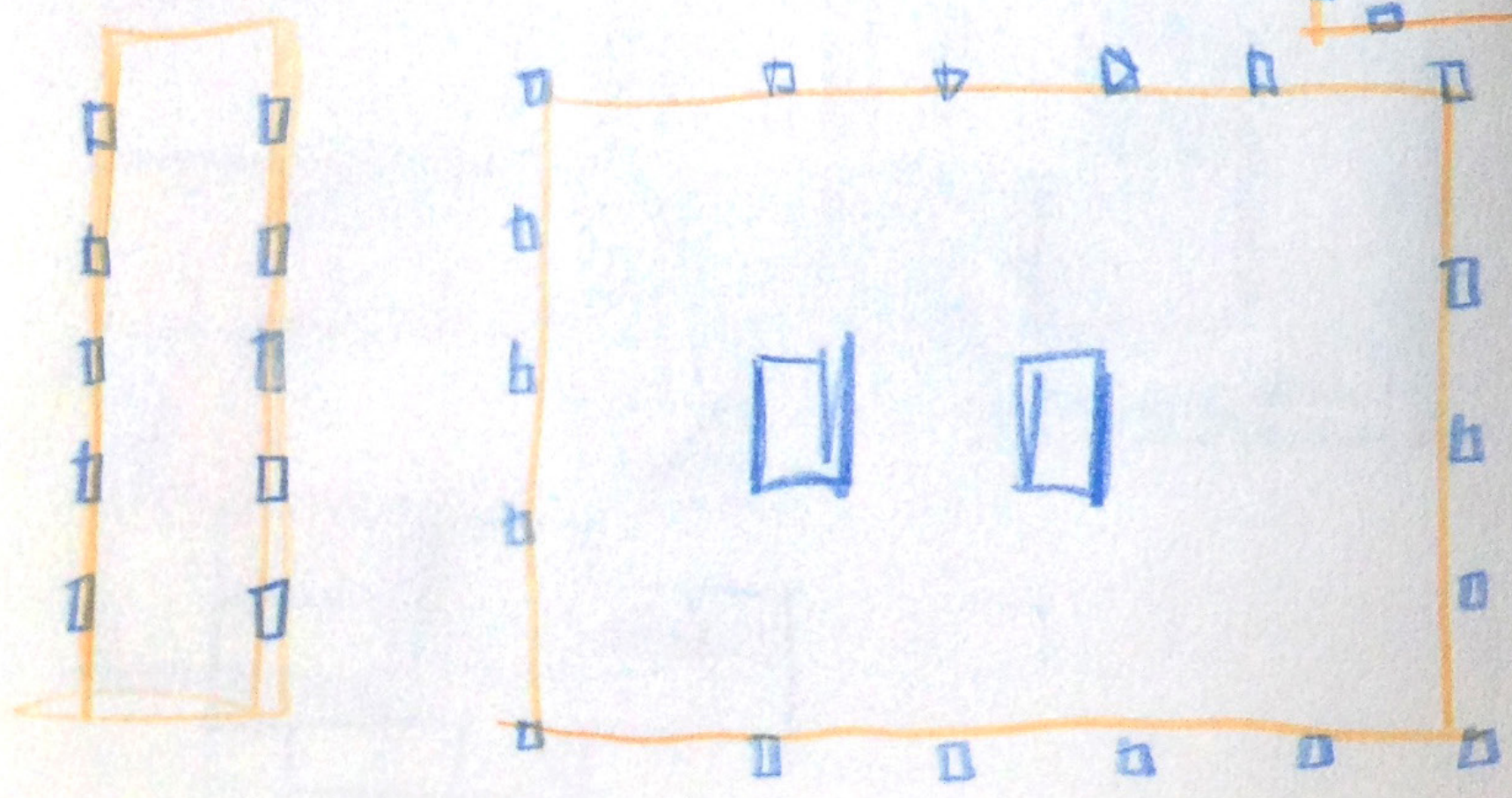
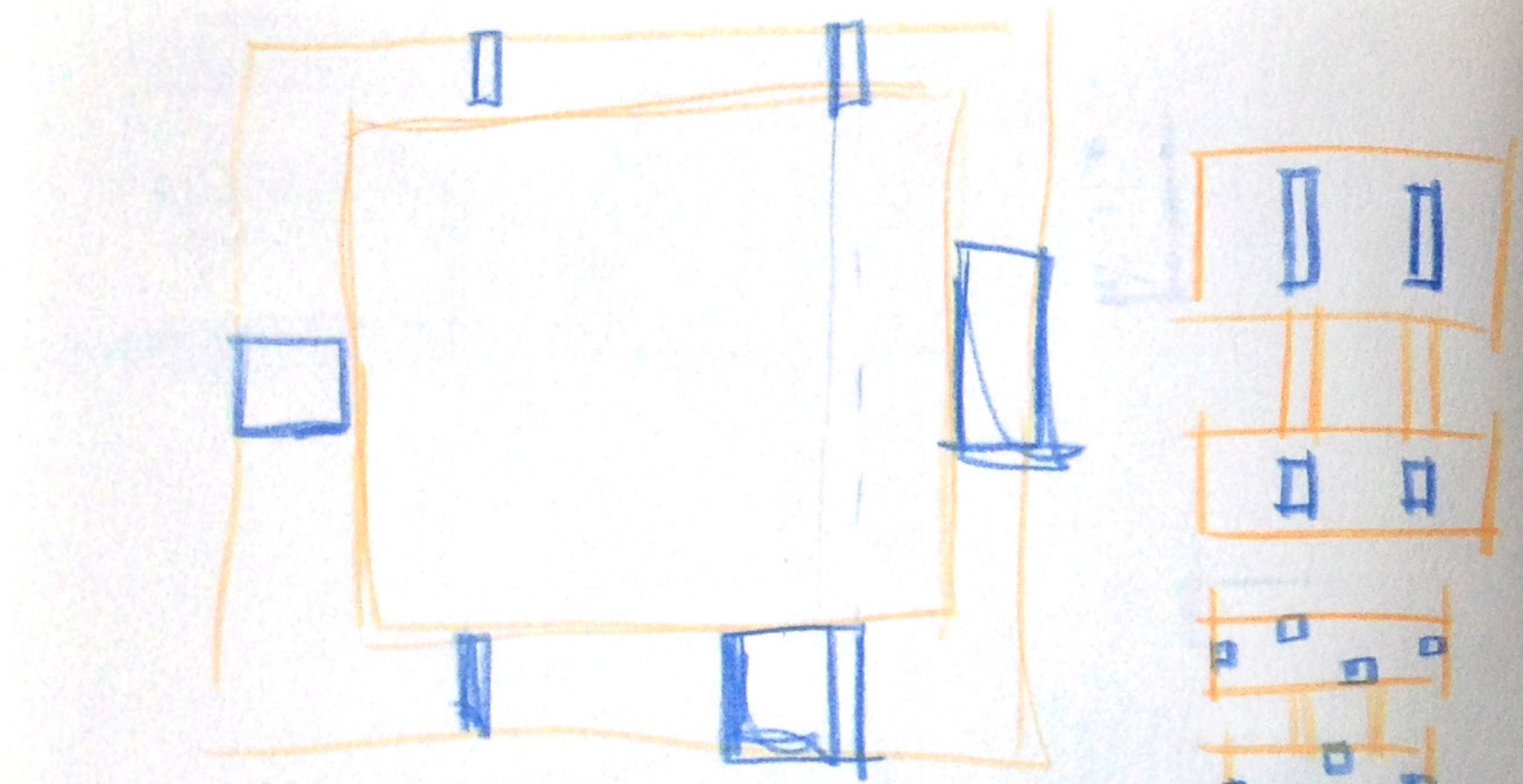



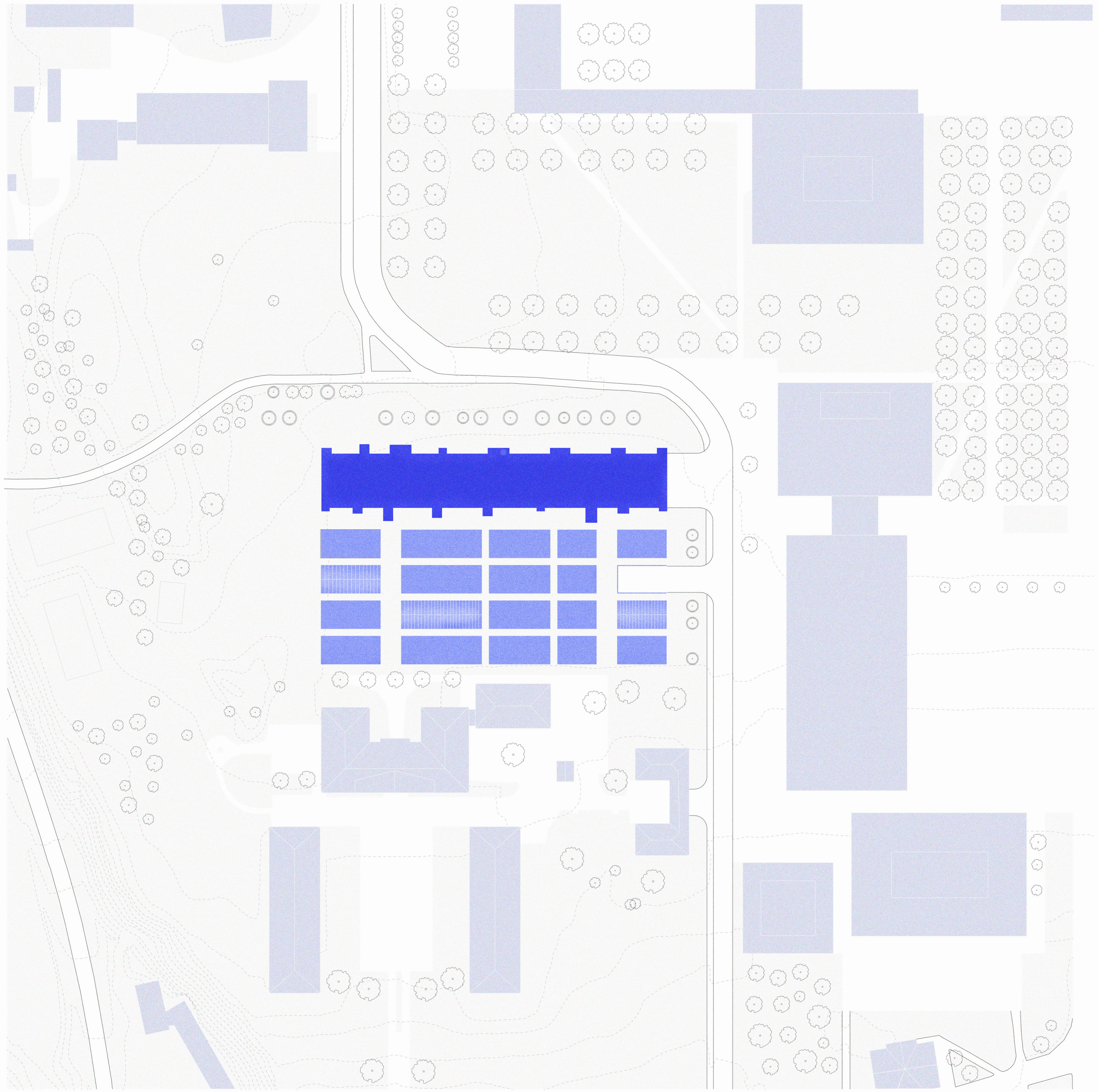



BSL-4

Biosafety level 4 is the highest biosafety level possible in laboratories. It is suitable for working with dangerous/exotic agents, which post high individual risk of aerosol-transmitted laboratory infections that are frequently fatal, for which there are no vaccines or treatments. There is strict access control, and researchers do a complete change of clothes upon arrival, the use of positive pressure personnel suits and so on. The air supply and exhaust is dedicated to the BSL-4 and is filtered with HEPA both in and out, and all equipment is decontaminated.

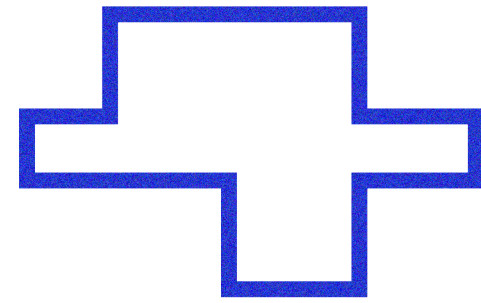

ABSL-3

The ABSL-3 laboratory has stricter requirements than the ABSL-1. The entrance is through a change room, with airlock, where needed laboratory clothing and shoes are put on. All windows and penetrations are sealed. The animals are kept from daylight, and most of the work is done in biosafety cabinets, and there is a negative airflow into animal and procedure rooms. An autoclave is required in the laboratory, and hand-washing sinks are required by the exits.

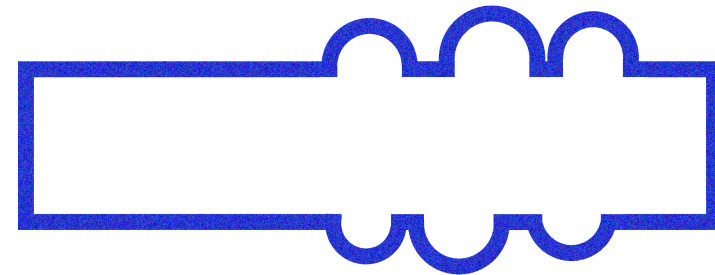

ABSL-1

An ABSL-1 laboratory is a laboratory where animals are used for research. As with the BSL-1, the agents in this specific safety level are not known to consistently cause diseases in healthy adult. The animals need to be kept in rooms without daylight, as their daylight rhythm is to be constant, and another requirement is that there is no recirculation of exhaust air. Hand washing sinks need to be available throughout the lab.



BSL-2

A laboratory with biosafety level 2 is suitable for working with agents associated with human disease, with routes of transmission including ingestion and mucous membrane exposure. The BSL-2 requires more limited access, biosafety cabinets, and an autoclave available in the same building.



BSL-1

A laboratory with biosafety Level 1 is suitable for working with agents not known to consistently cause diseases in healthy adults. Facilities required are laboratory benches and sinks.

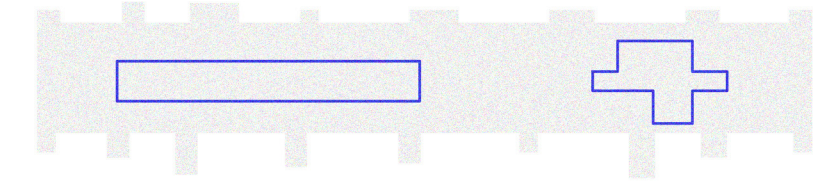

8

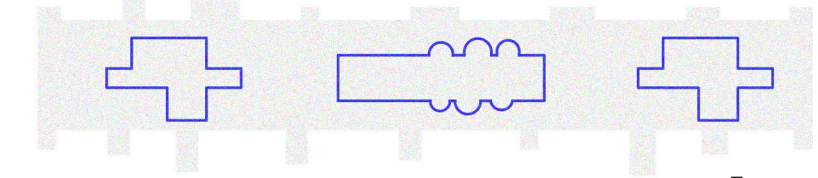

7

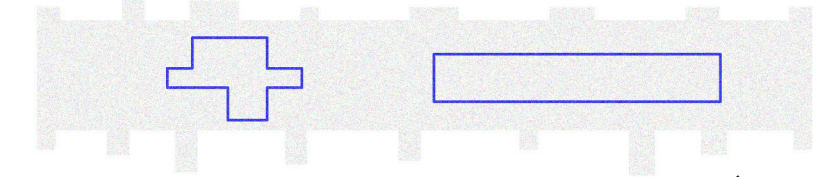

6

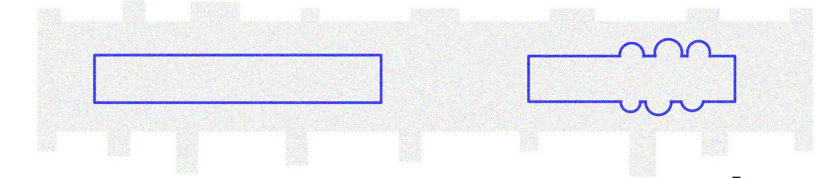

5

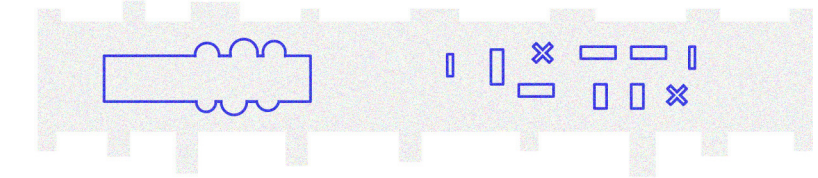

4

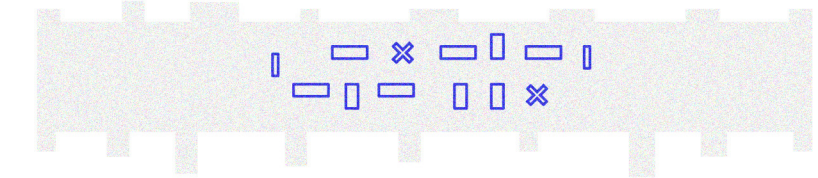

3

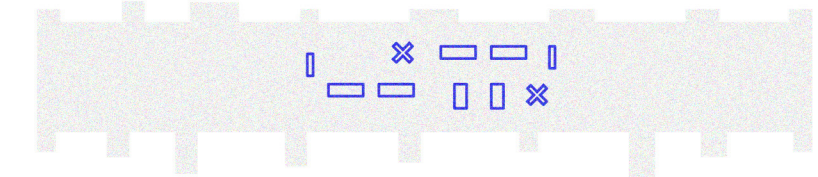

2



1



Diagram of the laboratories, longitudinal section.
1:200

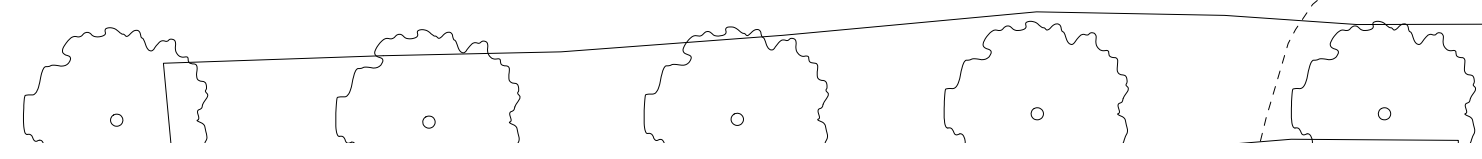
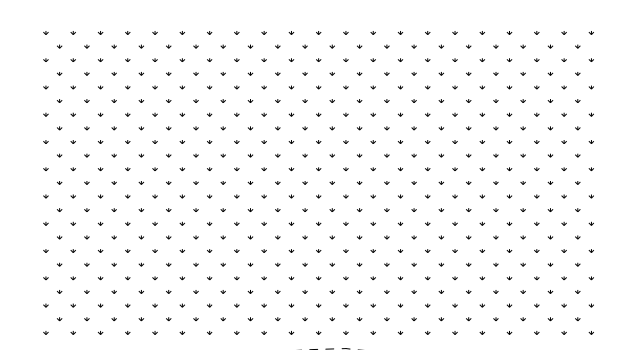
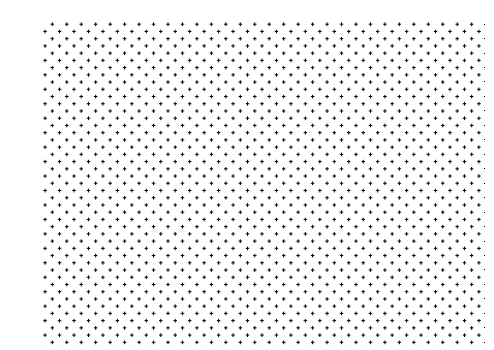
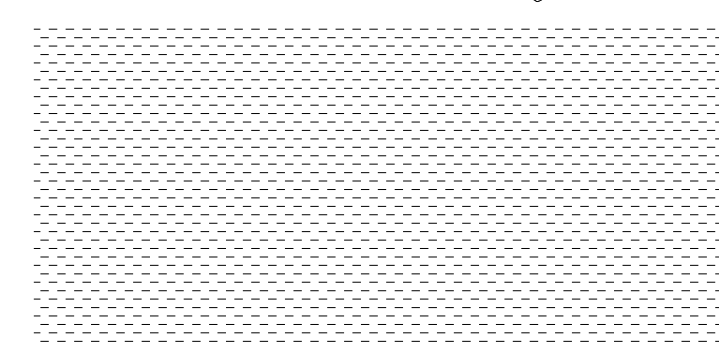
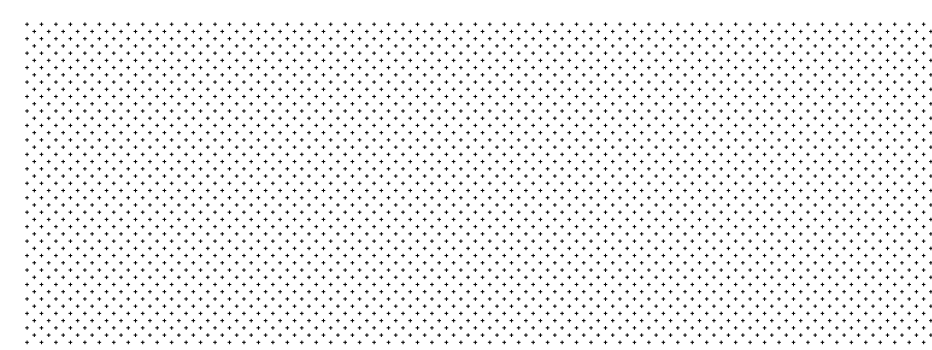
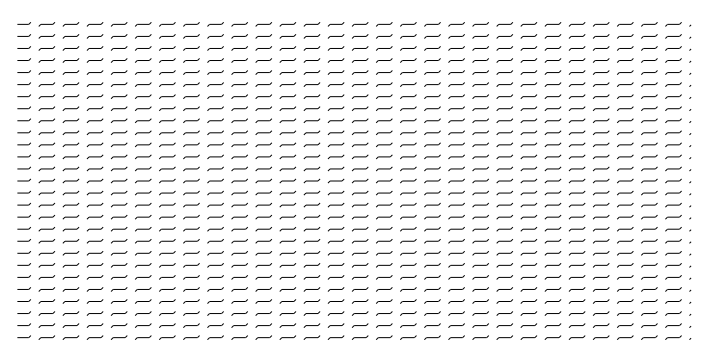
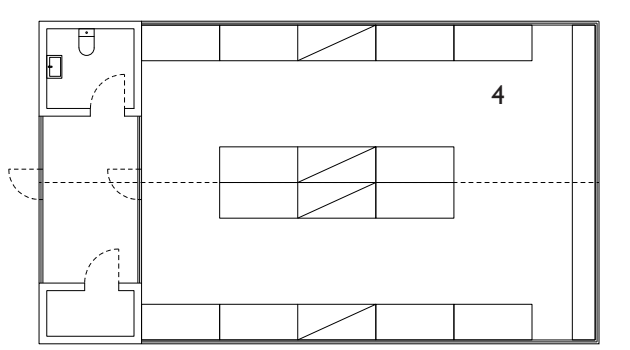
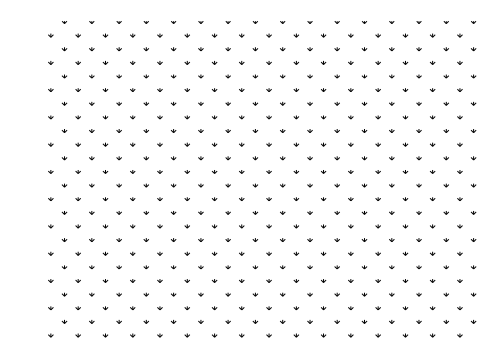
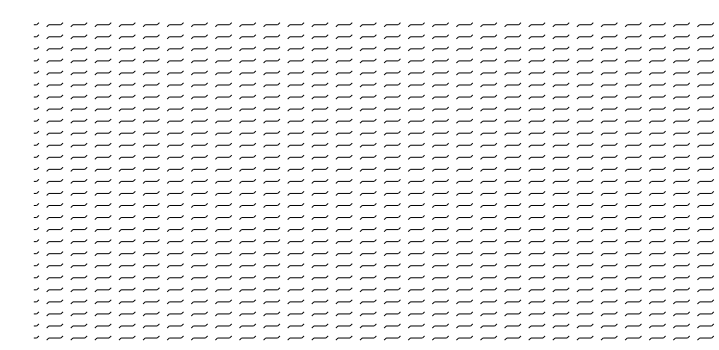
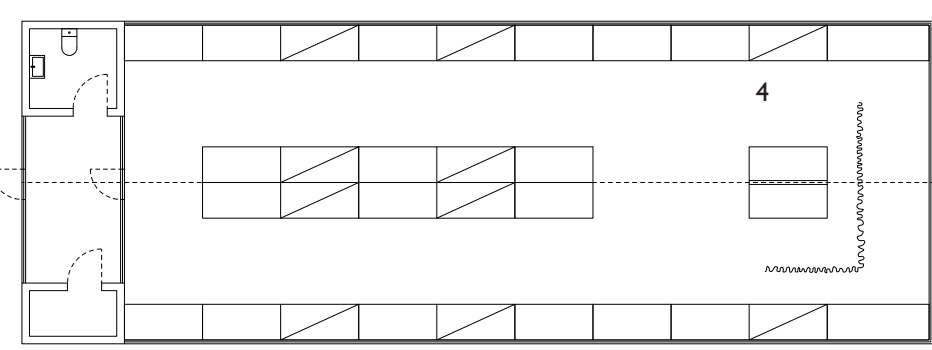
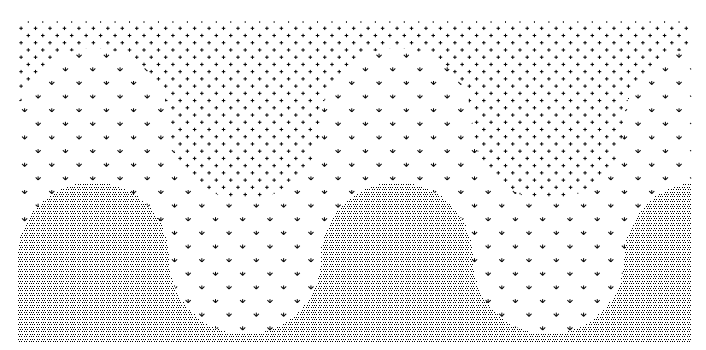
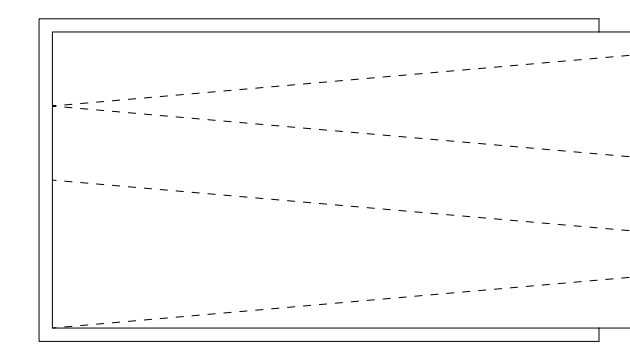
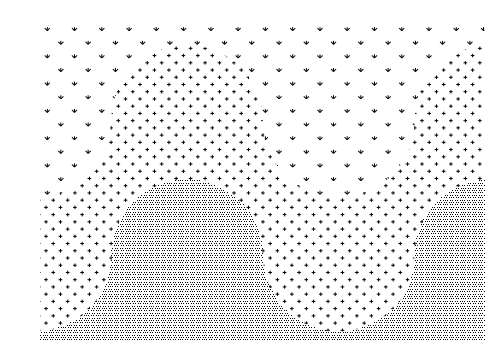
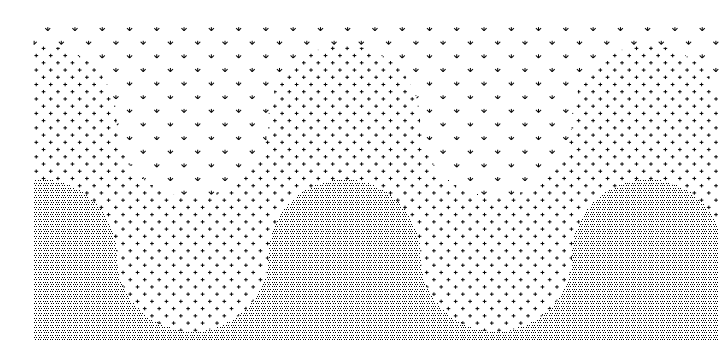
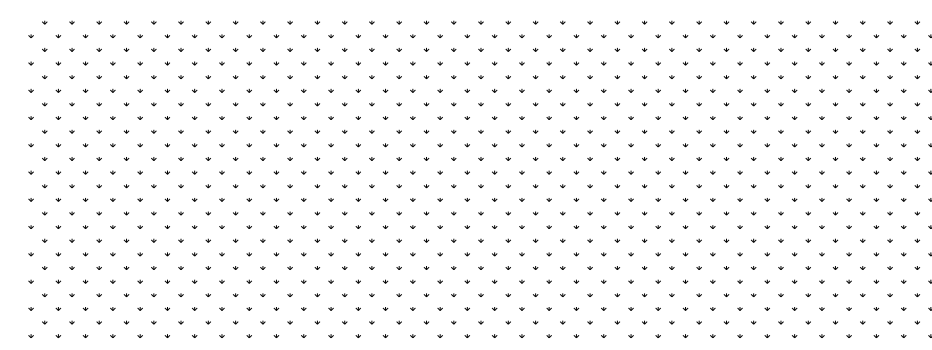
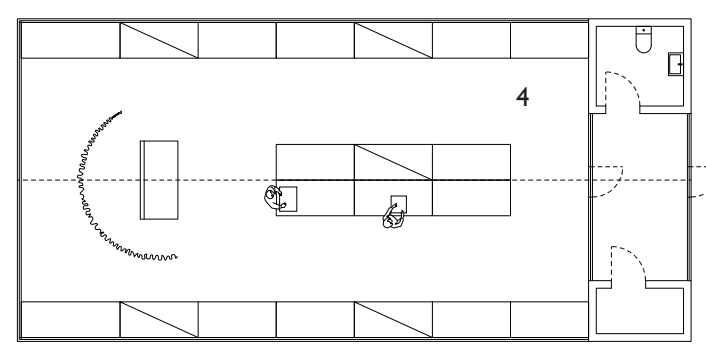
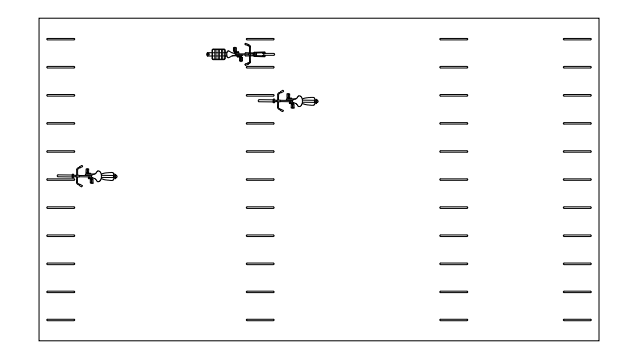
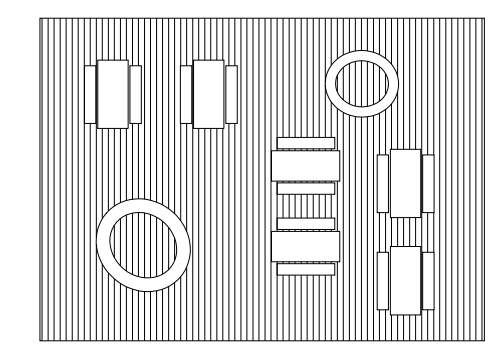
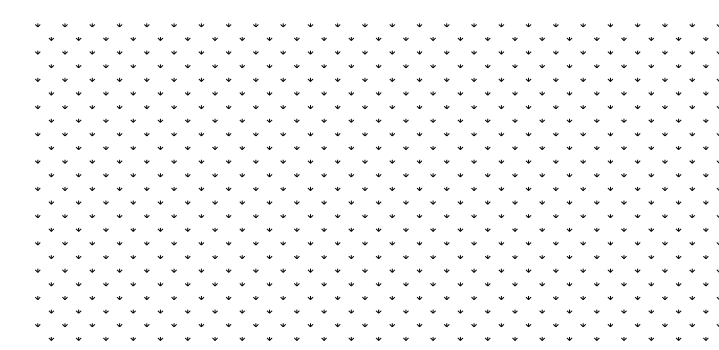
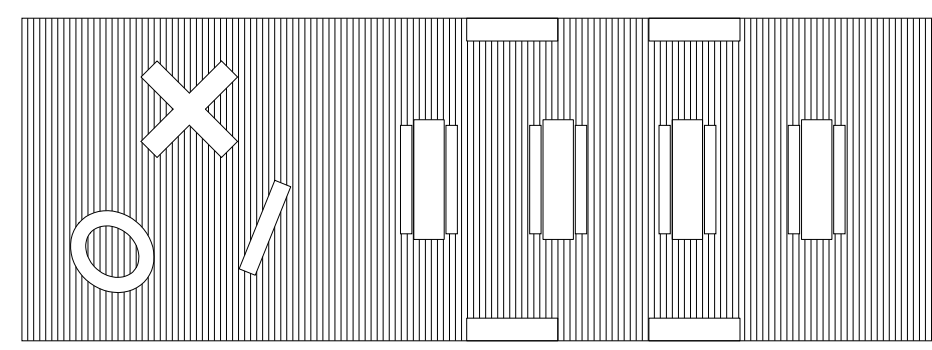
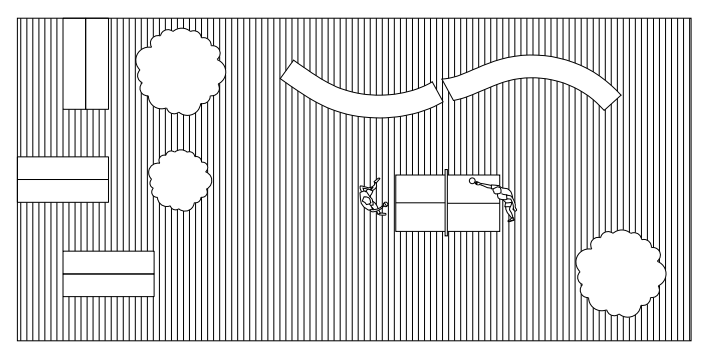
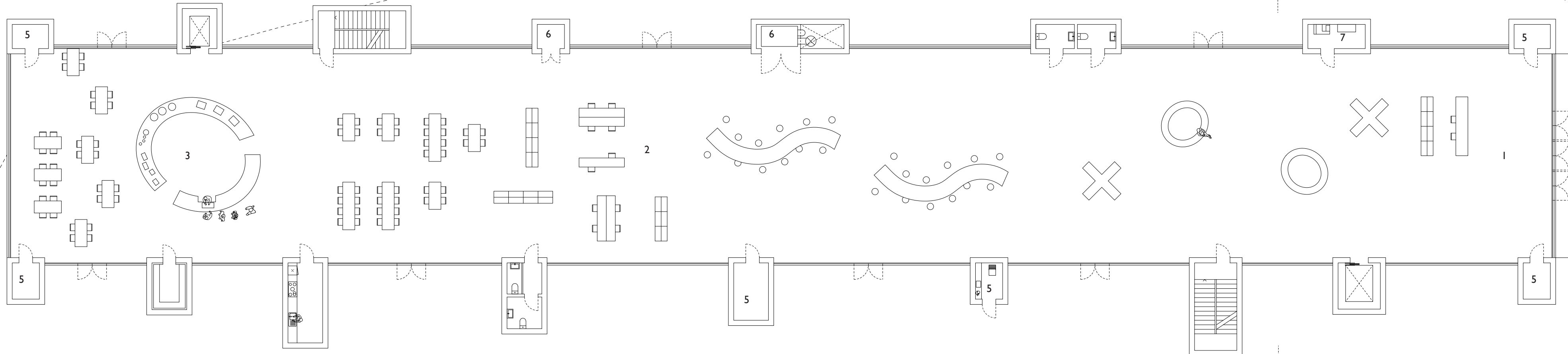
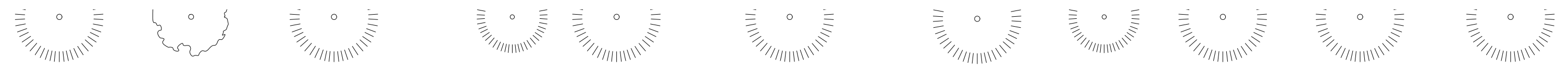

ASSTUDIO

ASSTUDIO

ASSTUDIO

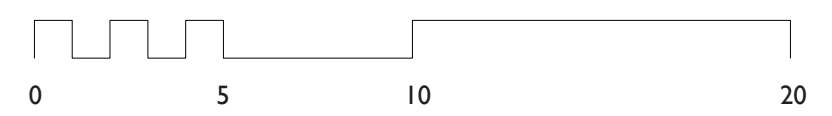
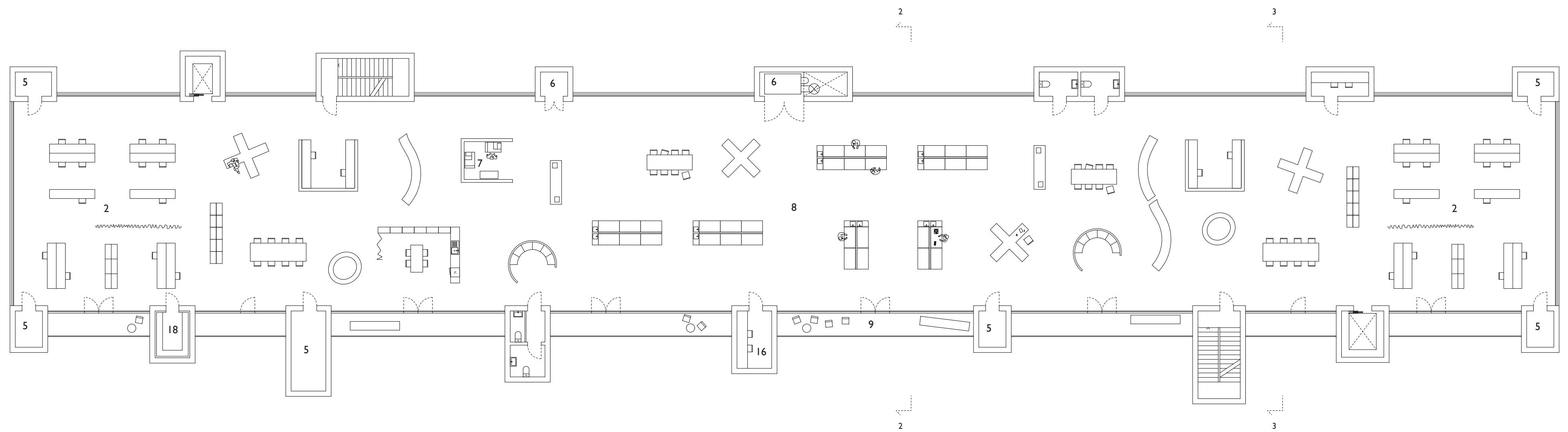

- | | | |
|------------------|-------------------|---------------|
| 1 entrance | 8 BSL-1 lab | 15 ABSL-3 lab |
| 2 work space | 9 balcony | 16 microscopy |
| 3 cafeteria | 10 autoclave room | room |
| 4 green house | 11 trolleys | 17 workshop |
| 5 storage | 12 BSL-2 lab | 18 cold room |
| 6 technical room | 13 ABSL-1 lab | |
| 7 copy room | 14 BSL-4 lab | |

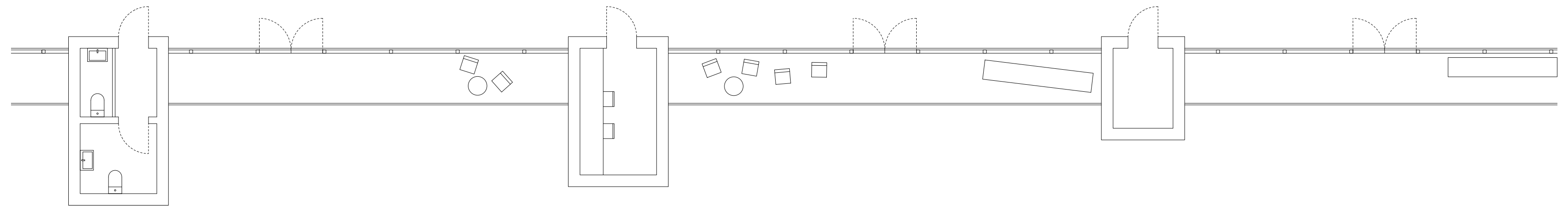
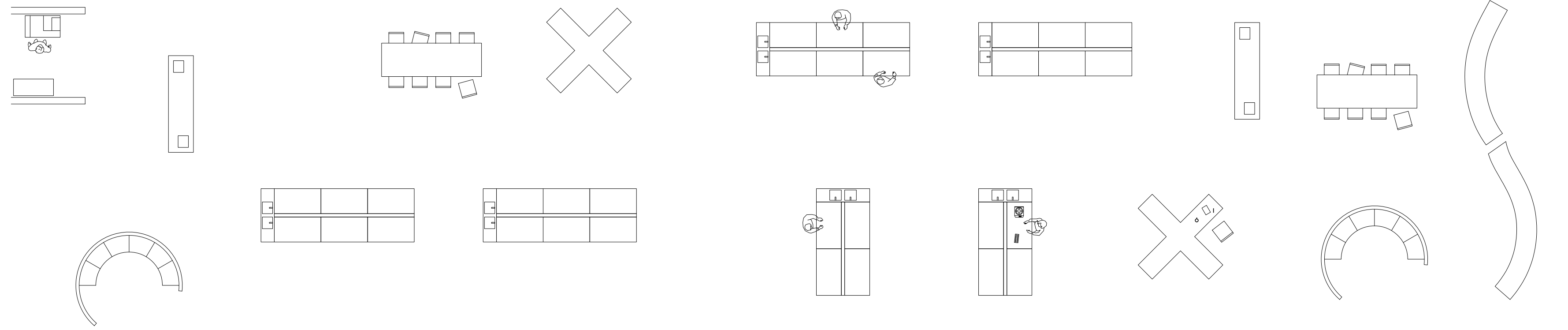
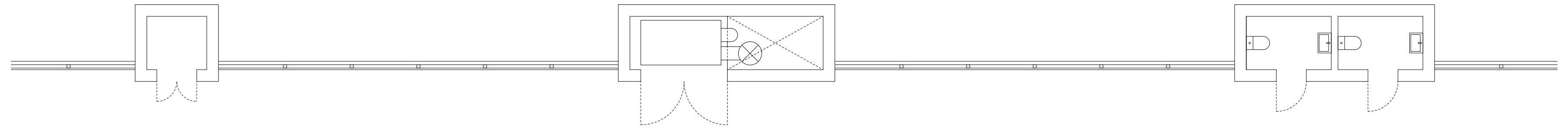

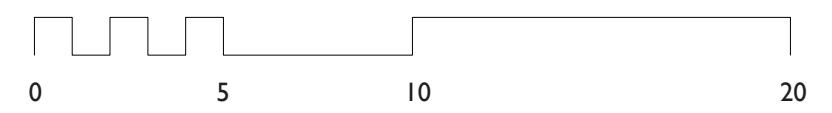
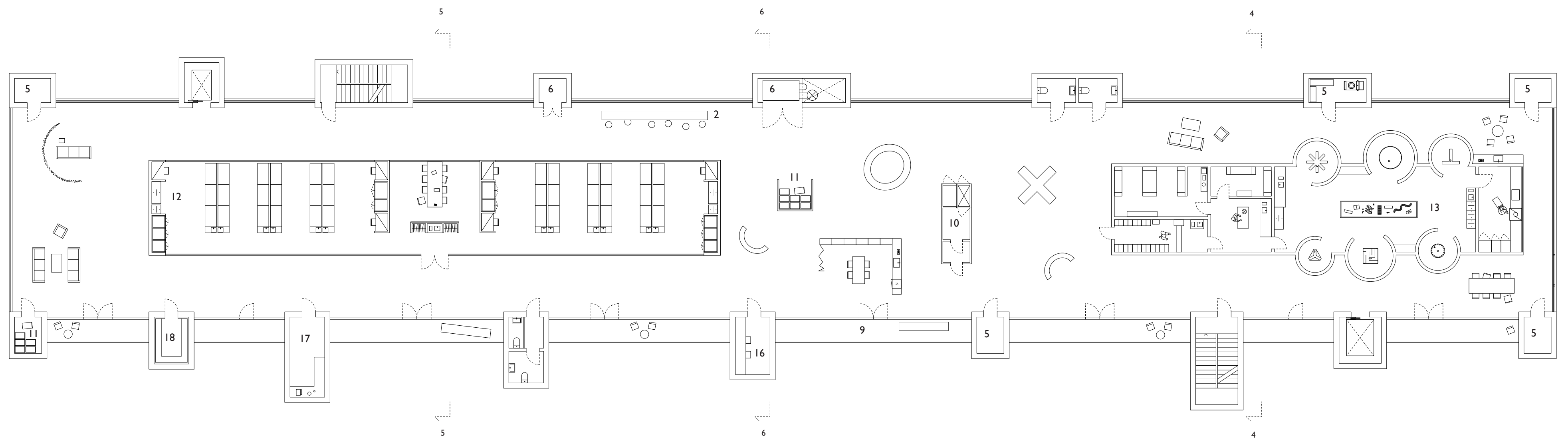

- | | | |
|------------------|-------------------|---------------|
| 1 entrance | 8 BSL-1 lab | 15 ABSL-3 lab |
| 2 work space | 9 balcony | 16 microscopy |
| 3 cafeteria | 10 autoclave room | room |
| 4 green house | 11 trolleys | 17 workshop |
| 5 storage | 12 BSL-2 lab | 18 cold room |
| 6 technical room | 13 ABSL-1 lab | |
| 7 copy room | 14 BSL-4 lab | |

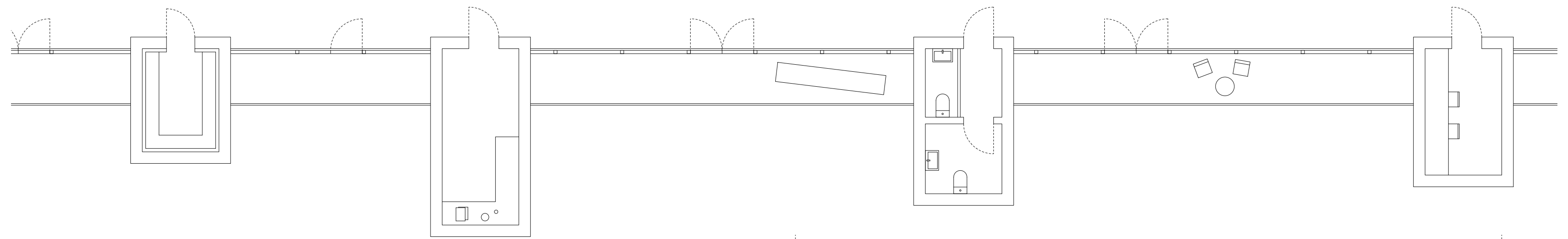
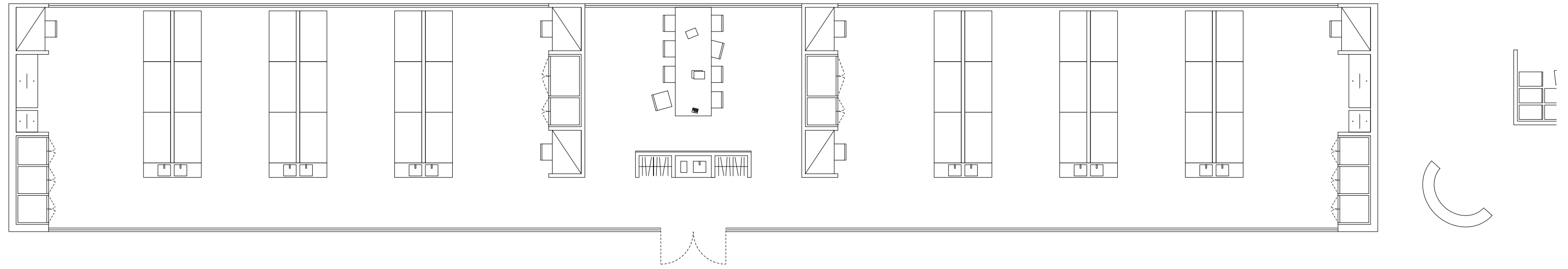
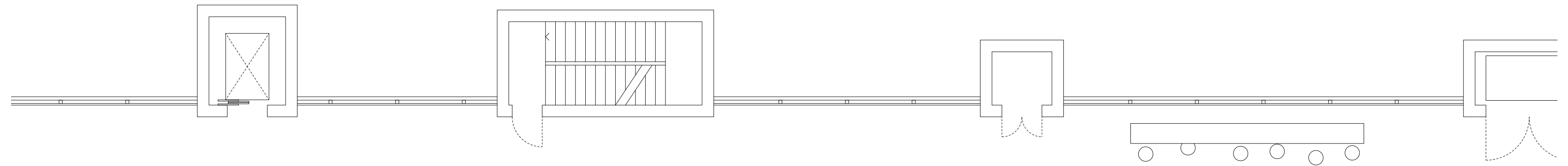

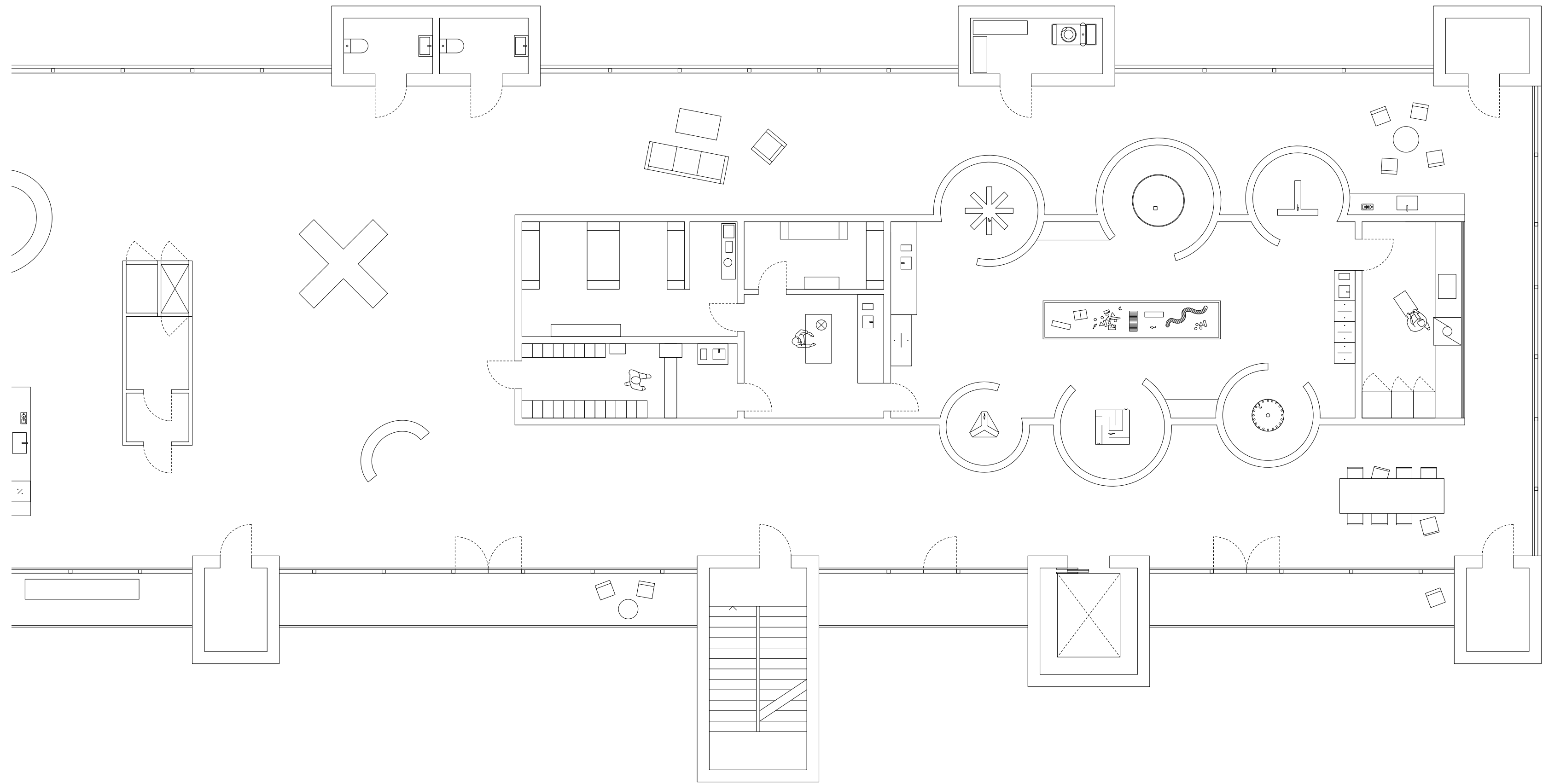

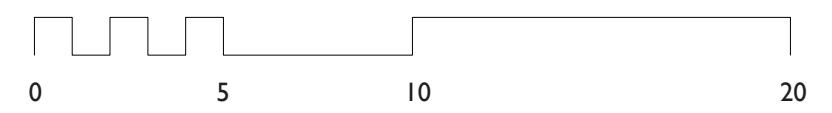
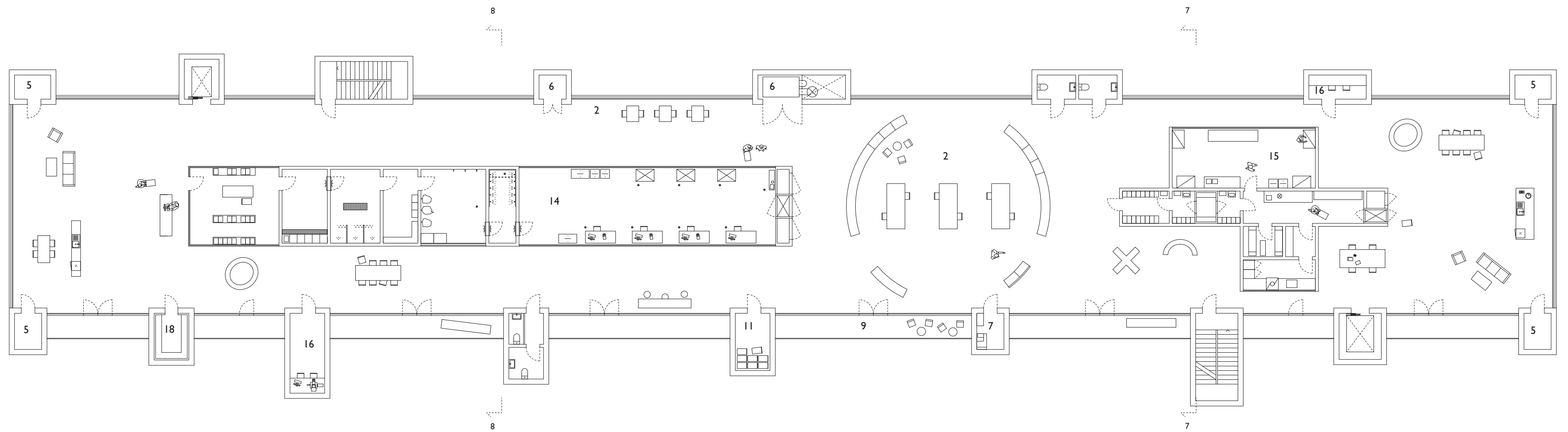

- | | | |
|------------------|-------------------|--------------------|
| 1 entrance | 8 BSL-1 lab | 15 ABSL-3 lab |
| 2 work space | 9 balcony | 16 microscopy room |
| 3 cafeteria | 10 autoclave room | 17 workshop |
| 4 green house | 11 trolleys | 18 cold room |
| 5 storage | 12 BSL-2 lab | |
| 6 technical room | 13 ABSL-1 lab | |
| 7 copy room | 14 BSL-4 lab | |

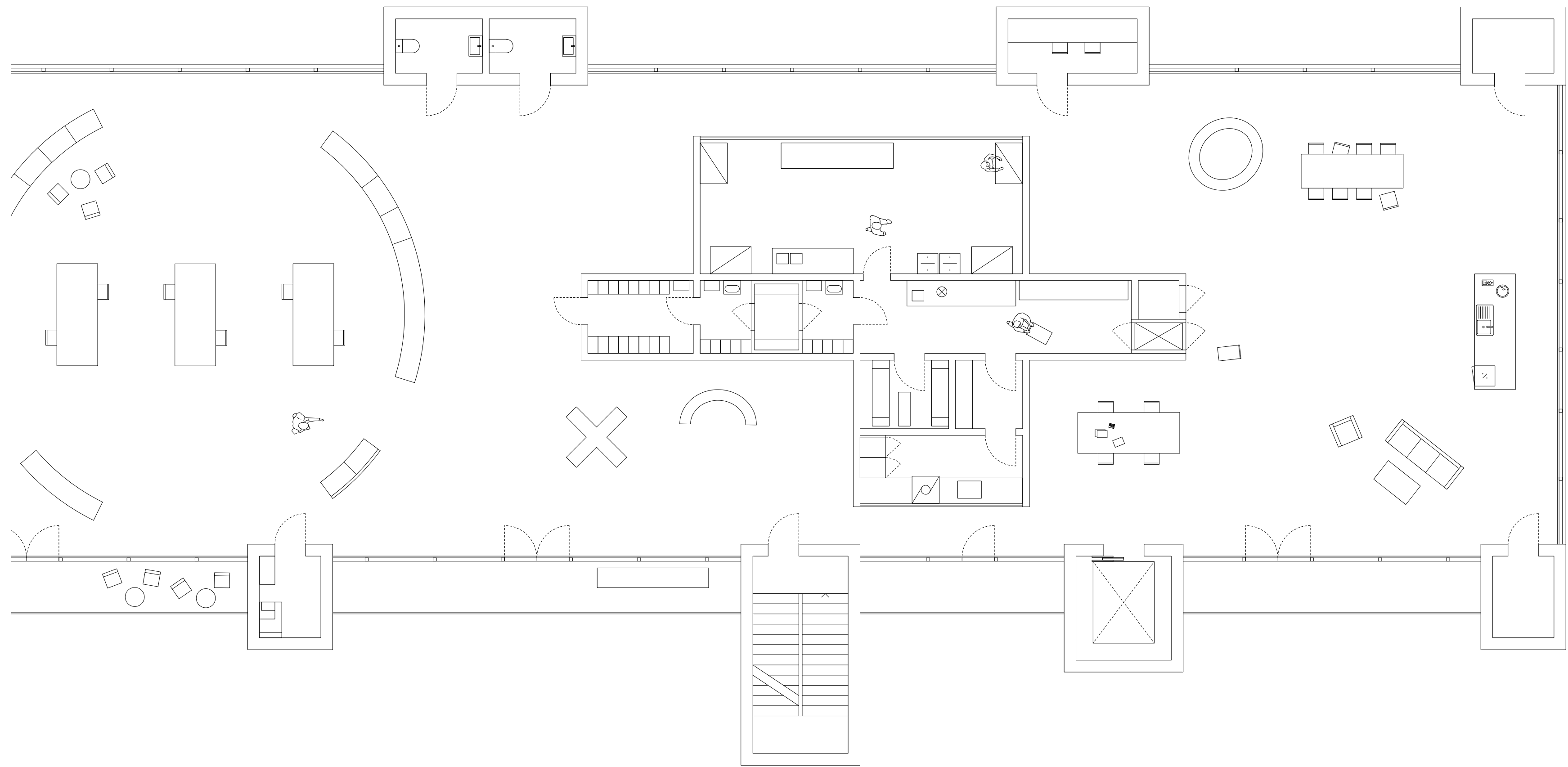

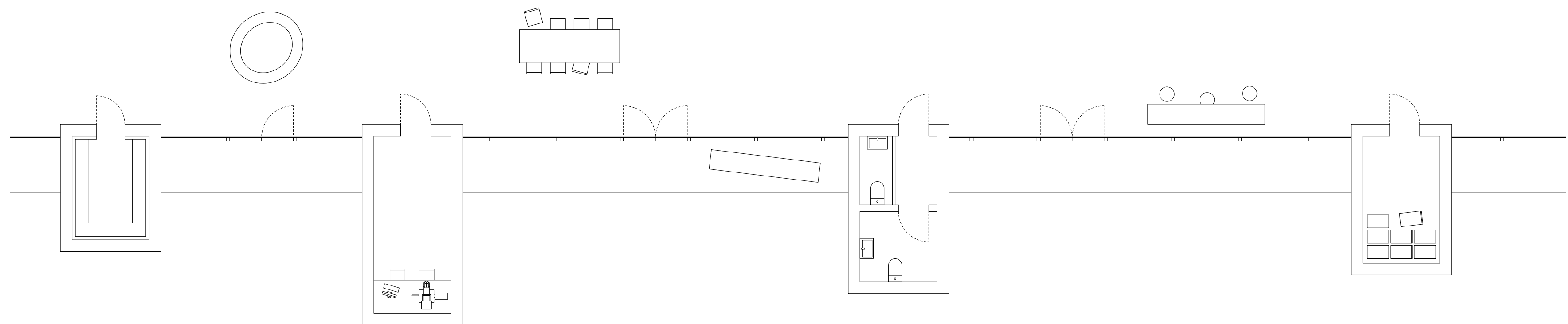
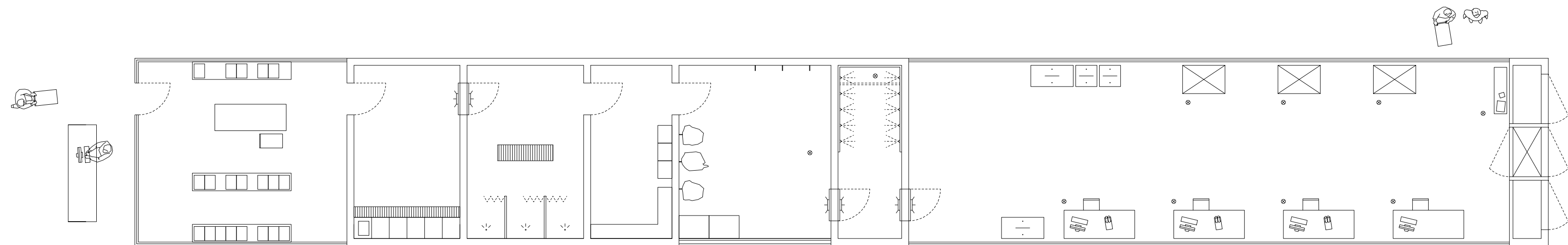
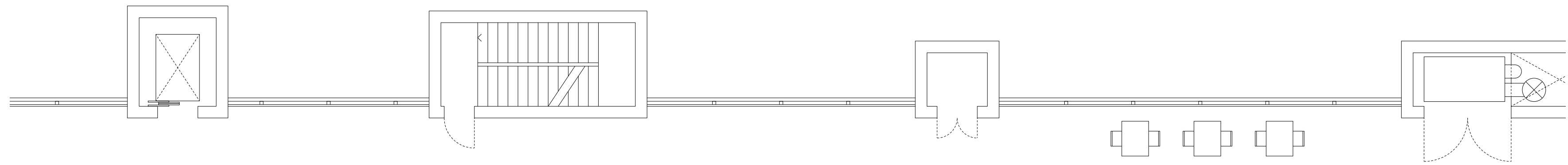



Cross section.

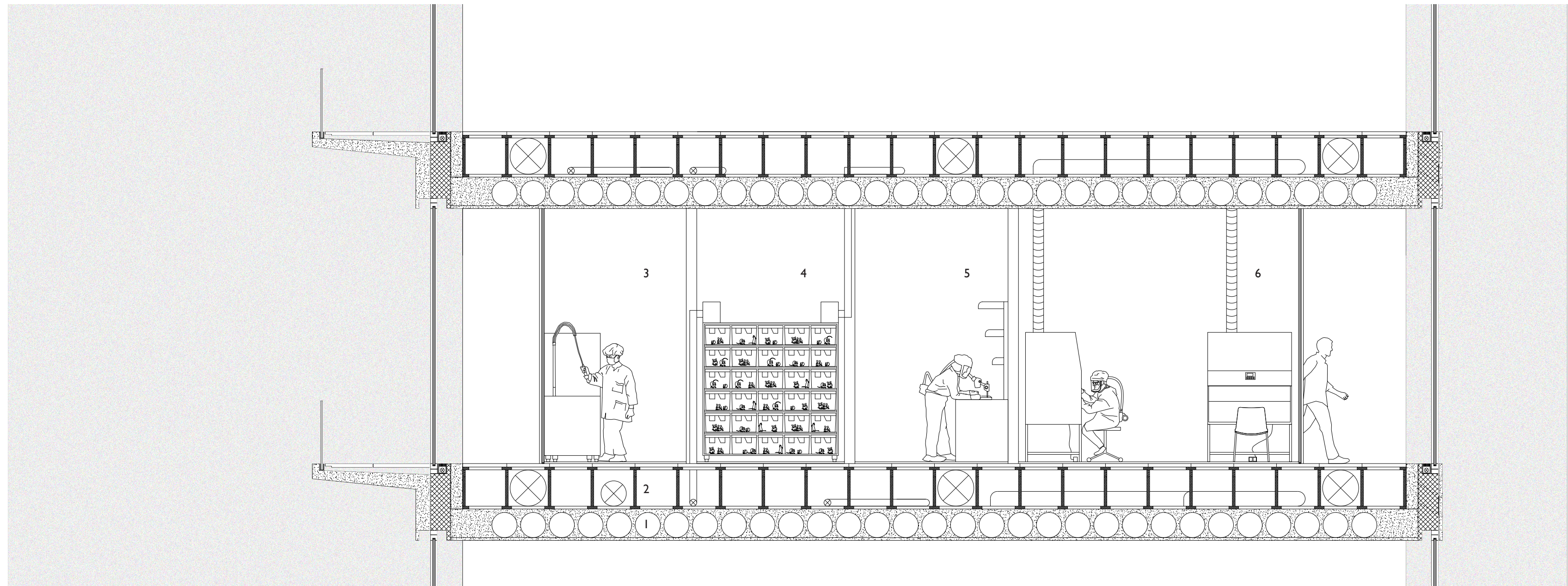

- 1 bubbledeck
- 2 technical floor
- 3 ABSL-3 laboratory, cage washing room
- 4 ABSL-3 laboratory, animal room
- 5 ABSL-3 laboratory
- 6 ABSL-3 laboratory, biosafety cabinets

Section through an ABSL-3 laboratory.
1:50

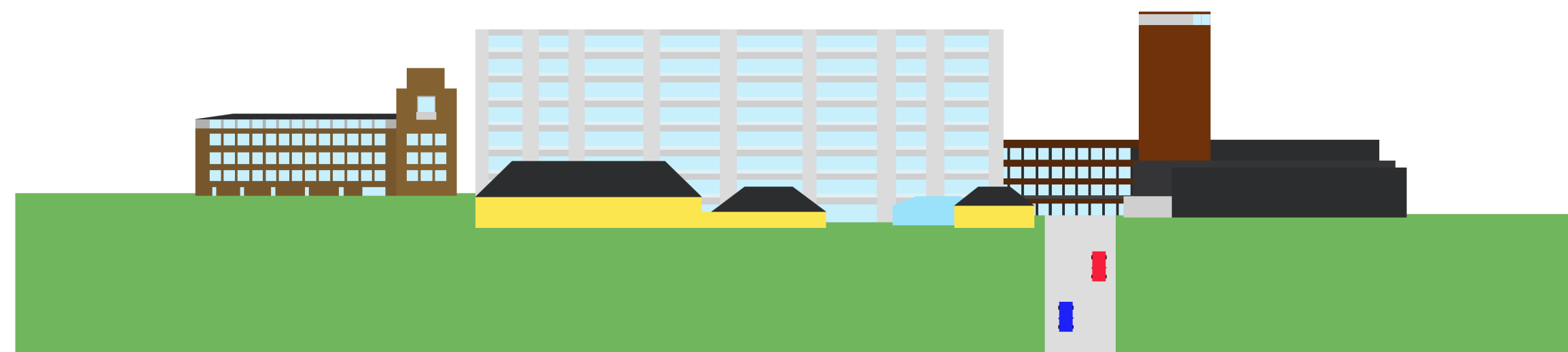

Situation at Blindern. Laboratory building seen from South East and North West.

