

THE OSLO SCHOOL OF ARCHITECTURE & DESIGN, 2017

# THE AVATAR

EXPLORING THE USE  
OF EDUCATIONAL AND  
SOCIAL AVATARS

DIPLOMA PROJECT

TEA SKOG & ASLAK SØDAL

PRODUCT & TANGIBLE INTERACTION DESIGN







Dear reader

In this report will we guide you through our diploma journey. You will get to meet the important people we have meet that have shaped our project, get to know the context we have worked within and our focus point. We want to show how we have practical tackled it making/designing and then in the end show you our design proposal.

Hope you find it interesting, we sure have.

Ally Scott

Tea Skog







# CHAPTERS

1

**INTRODUCTION  
& EXECUTIVE SUMMARY**

PAGES 5-17

2

**CURRENT SITUATION  
& SOLUTION**

PAGES 18-27

3

**USER & CONTEXT  
RESEARCH**

PAGES 38-47

4

**TRENDS**

PAGES 48-57

5

**CONCEPT DEVELOPMENT**

PAGES 58-95

6

**DESIGN PROPOSAL**

PAGES 96-111

7

**OUR REFLECTIONS  
& ACKNOWLEDGEMENTS**

PAGES 112-115

8

**REFERENCES**

PAGES 116-118





PICTURE Tea Skog & Aslak Sodal



# 1 INTRODUCTION & EXECUTIVE SUMMARY

IN THIS CHAPTER:

We will introduce ourselves, our supervisors and our project partner, No Isolation.

We will discuss the contributions this project delivers, the framework we have worked within, and the methods used. Finally we will give a short overview of how this report is structured.

# I N T R O D U C T I O N



# A B S T R A C T

## ABSTRACT

Working with the startup No Isolation, we have designed a new proposal for their existing product, the AV1 - an avatar used in educational and social settings for long term sick children. To help prevent social isolation and loneliness the avatar represents the child when they are not able to be physically present. The avatar needs to be able to join in where the child cannot.

We have investigated how the existing solution works and identified challenges. Our insights showed that the technical functions and concept of the AV1 is strong and well thought out, however the physical shape and materiality of the avatar prevents them from being utilized and prevents users from using it as intended. We have based our project on the concept, and the existing technology of the AV1.

Our diploma is within the field of tangible interaction and product design, this has given us many areas to explore. We have specifically focused on the users interacting with the avatar, how to transport and include the Avatar, and how to read information from it and exploring material use.

Our final proposal is a redesign of the AV1 resulting in a new product, the Avatar Mate, AM8.

# INTRODUCTION

## OUR BACKGROUND



### TEA SKOG

Tea has her background from social anthropology and psychology studies before choosing her path with furniture and spacial design at KhiB.

For her masters degree at AHO she has specialised in product design.

This background has given her a wide perspective to guide her design work..



### ASLAK SØDAL

Who has two thumbs, and loves robots? This guy.

Aslak has his background at AHO for five years, With a passion for both digital and physical design, he has specialized in tangible interaction design, 3D printing and systems oriented design.

## DESIGN FIELD

This project is set in between Product- and Interaction design, in the field of Tangible Interaction Design.

Combining our strengths, we have been able to use each others knowledge all the way through the process, and into the final design proposal.

# INTRODUCTION

## SUPERVISORS & COLLABORATORS



NICK STEVENS  
MAIN SUPERVISOR, AHO



GEIR ØXETH  
SECONDARY SUPERVISOR, AHO



WILLIAM KEMPTON  
SECONDARY SUPERVISOR, AHO



### NO ISOLATION

This diploma is based on a brief given, and previous work done by No Isolation, a Oslo-based Startup company.



# INTRODUCTION



# I N T R O D U C T I O N

## OUR MOTIVATION

**When we were approached by No Isolation through our supervisor Nick, we had no conception of what this project would entail.**

We started off after a short introductory meeting with Karen Dolva and Anna Holm Heide from No Isolation, where we were introduced to the AV1. The AV1 is a small robotic avatar that takes a sick child's place in education and social life, when they cannot be there themselves. We were also introduced to what they foresaw as a project for us in rethinking and redesigning the AV1. After this meeting, we were both very positive towards working with this assignment for our diploma.

### **Personal**

We both have backgrounds in working with children and youths. Both as teachers, youth workers, and social event organizers, our engagement for working with, and helping young people runs throughout our entire education and life.

The opportunities the AV1 promises children suffering from long-term illnesses, and the hope it gives them has for us been a great motivating factor, and gives us a sense of purpose when working with this diploma. We genuinely feel that with this project, we have a chance of improving someone's life. Neither of us have worked with robots in this way before. We have both taken courses in tangible interaction design at AHO, so we were very interested in the concept behind the AV1. We see this diploma as a great chance to work with a very relevant project and an engaging arena.

Working together as a group on the diploma has been a motivation to always do our very best, and not disappoint each other. We have seen it as a benefit to be two very different people, with different strengths and approaches that have shaped our project.

# INTRODUCTION

## PROJECT FRAMEWORK

On the following pages we will go through the framework of this diploma. The brief and our goals, the methods we have used and why.

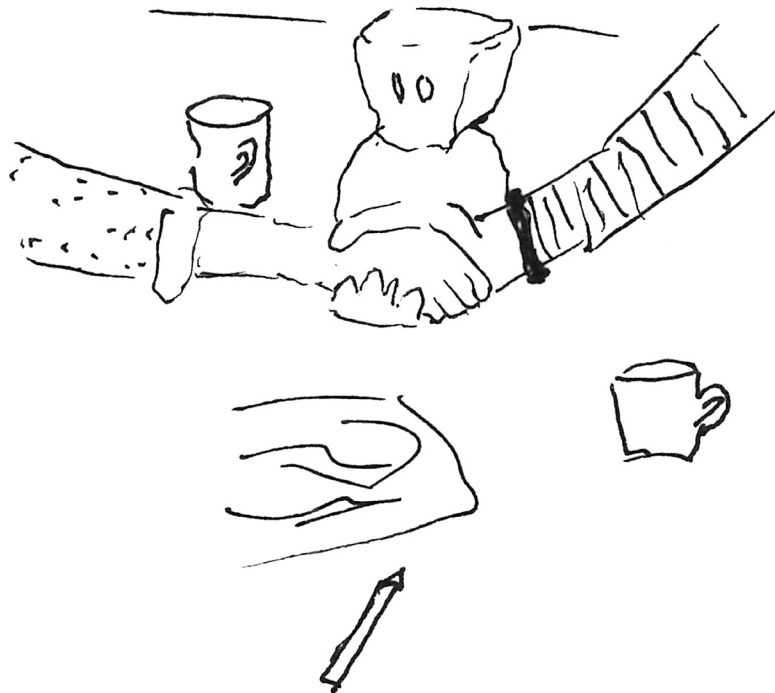

# I N T R O D U C T I O N

## BRIEF

### OUR BRIEF

Working with the startup No Isolation, we will investigate their first product, AV1 - an avatar used in educational and social settings for children who are absent for longer periods of time due to illness; and we will design a new proposal.

AV1: How is it working? How is it not working? Who are the users and how do they interact with the Avatar? Can these interactions be changed/improved?

### OUR GOAL

For this diploma we will design and create a prototype for a new robotic avatar that will solve some of the challenges found in the existing solution. The purpose of the new design is to give the primary user more possibilities to emote and express themselves through the robot avatar and invite secondary users to interact more and build closer relationships with the avatar. We will explore this through the use of materials, shape and expressions. The environment of the robotic avatar is a educational and social setting

### EDUCATIONAL SETTING

The concept we have worked with is situated both in a educational setting, and a social setting. To get an overview of the need of the secondary users seen in educational settings, we have talked with pupils, observed them in the classroom and participated in classes.

### SOCIAL SETTING

To understand the social settings the concept will be in, we have interviewed, tested and observed children and youth in their social life outside school. At home, with friends and in extra curricular activity.

### STARTING POINT

We chose to work with the secondary users of the avatar. By secondary users, we mean the users that have no direct control of the avatar, but interact with

it. These users can be teachers, peers, friends or family of the sick child (primary user). Today's solution focuses primarily on the needs of the primary user, and we see a potential in focusing on the space the avatar is placed in and the people interacting with it.

Since this project revolves around redesigning a robot, this diploma started out getting a thorough understanding of robots, where the technology is going, and where it has come from. From the get go of the project we both thought many of the existing solutions are inhuman, cold and lack any capability of expression. To see why, we researched liberally into other projects involving creating emotional responsive robots, how humans react to "non-living" life, and how we could use what we know as designers combined with what roboticists and technologists do to understand the field.

The biggest problems we see is the fact that most robots today that are not direct toys, are made for a professional user, in a professional or industrial setting. Very few robots or machines are made with a human "closeness" in mind, creating a divide between people, and the machines we interact with.

### FOCUS

We chose to work with the secondary users of the avatar. We will use the existing concept and we will develop a new design proposal.

We will look at technical aspects but they are NOT a focus in our proposal. We have however had close conversation with Henrik Malvik Halvorsen who is a Roboticist from the Norwegian University of Science and technology in Trondheim to know that what we are exploring is feasible and possible.

We have reflected on both regulations and the ethics of the concept throughout the project. While we see this product as a part of a bigger system, regulations and restrictions must be made by professionals within the fields it affects, not by us.



## METHODS

### METHODS

**Our project has involved several phases, each with its own methods. First we needed to understand the chosen field, then analyze and synthesize our findings into concepts and trials, and finally create a design proposal through conceptualizing and modelmaking.**

#### LITERATURE & DESKTOP RESEARCH

Many of our initial insights were gained from a thorough literary research within robotics, social isolation and loneliness and social communication.

Digital media such as movies and Ted-talks were also used to get a deeper understanding of what has been done in these fields before.

References can be found at the end of this report.

#### USER MAPPING AND SYSTEMS MAPPING

Using Aslak's background in Systems Oriented Design, we have conducted extensive mapping to get an understanding of the field we are working in, and the challenges that can be found within it.

Understanding and mapping out the needs and demands of the different users resulted in a detailed list of demands later used for generating our new proposal.

#### STATE OF THE ROBOT ARTS

Understanding where and what robots are doing today has been fundamentally important for this project. Understanding what the available technologies have to offer, and how we can differentiate our product from other existing products will decide how our final prototype will turn out.

#### CHOSEN USERS

From an early stage we chose to focus on the secondary users of the avatar. Using the insights of experts, we gained a greater understanding of the situation today, and how it could be improved.

#### MEETING EXPERTS

Since our project, and the existing solution, sit squarely both in an educational setting and a social setting, we have met experts from the least familiar field; the educational setting.

Read more about our project experts on the next spread.

#### PUBLIC DISCOURSE

Over the course of the project, we have followed the intense media coverage of the AV1, and No Isolation. In periods there has been more than 2 articles or reports a week in the news about the product and what it offers. There has also been public discussions in the news and in social media going back and forth surrounding the privacy-question of the concept, and its use in classrooms.

Balancing the positive and negative views portrayed in media, with our own thoughts and views has shaped this project.

Rather than be intimidated by the intense interest the original solution has been receiving, we have viewed it as a positive. There is a great interest in the product and everyone we talked to had some idea or thought about the AV1.

# METHODS

## USER RESEARCH & INTERVIEWS

We have observed the interaction between teachers and students in classrooms we have visited to gain insights into how they act.

We have interviewed teachers about their classroom everyday to get more information about specific questions. Using a teacher questionnaire we gathered many insights that we could check and verify through our participatory observations.

## SKETCHING & CONCEPT DEVELOPMENT

Working in both 2D and 3D we have bounced ideas off of each other, swapped drawings and made mock ups in 3D low fi to get quick visuals to discuss. We have focused on quantitative sketching to not get bogged down by details too quickly and gone into qualitative drawings when we saw something we found interesting to explore further. We did the same with 3D mock-ups in cardboard/plastic sheet etc. together with Arduino to get a quick view of the interaction before we developed it in higher quality.

## FEEDBACK SESSIONS

It has been important to meet with No Isolation to hear what they think of our concept during the diploma. Seeing what they are doing on their own redesign, and comparing that to our proposal has been interesting, and a great motivation when we see our findings reflected in their own work.

## USER TESTING

User groups consisting of both teachers and children got to see our prototype and gave us valuable feedback that helped in defining our final proposal.

### CHILDREN

To validate and test our design, we conducted a user test session with three users in the primary age group, Birk, Ylva and Tea Oleana.

### TEACHERS

We have been in contact with teachers from all age-groups and positions. From class-responsible to principals. This gives us a great view on how different professionals view the AV1, and how they react to our new proposal.

## METHODS

### USERS & EXPERTS

#### EXPERTS:

##### **No Isolation**

We will be working with, and developing this project in a loose collaboration with the startup company No Isolation. No Isolation is a young Startup company in Oslo focusing on children with long-term illnesses.. Their stated goal is "Helping people out of loneliness; No Isolation helps people out of loneliness and social isolation. Everyone should have the opportunity to take part in their own life."

##### **Jorun Børsting & Alma Leora Culén**

Jorun Børsting at the Department of Informatics at the University of Oslo. She is researching the technological needs of children and young adults with ME. AV1 is a part of the PhD. Jorun has researched the use of AV1 by nine ME-ill children and young adults since the project prototype stage in 2015. We have had a great relationship and have had the privilege of getting to base our project on some of her work. Allowing us to quickly gain insight into how the main users, the children deal with the AV1, and what their needs and views are.

##### **Sunnaas Hospital**

We visited Sunnaas hospital, and spoke to Anne Karine Dihle to get a feel for how they view the solution, and similar technologies. They have a pilot project using the AV1 internally in the hospital, allowing the user to participate in the hospital social activities even while bedbound.

What they viewed as important was that a responsible person must be able to turn the avatar on/off as an override to protect the user and secondary users. Functions and solutions must be flexible/bespoke after needs. Huge belief in the concept.

This is not the setting we will be designing for, but getting an insight into how they would use it and how the medical world views the avatar is of value to our project.

#### EDUCATION:

To understand just what a solution would have to entail, we had to get a better understanding of the situations it would be in. We wanted to use qualitative methods in use such as observation and both informal and formal interviews.

We conducted three in-depth interviews with 3 teachers to reinforce our findings, and check our conclusions from our observation sessions.

One principal at a Ungdomsskole, one Highschool teacher, and a primary school teacher.

We also meet with one teacher and one substitute teacher and got feedback on our proposal.

We also went with No Isolation to meet two schools that had been using the AV1.

##### **Jung Elementary School - used the AV1**

The first school had a very close relationship with the user, and an attitude of solving the situation no matter the cost or work required. They had been using the AV1 regularly, and the feedback from the primary user (absent child) was very positive.

##### **Mølladammen Ungdomsskole - used the AV1**

They were very positive towards the concept, but thought the avatar itself was very bland. It is white and sterile, with no personality. They felt it should be more pimped out!

##### **Ruseløkka Barne- & Ungdomsskole, and Akademiet**

We went to two schools without an AV1 to understand how a "normal" classroom works. What situations occur, how is the classroom communication etc. In this way we can get a broad insight into user behaviour and habits - something that is often difficult or impossible to get reproduced verbally, even if users are asked directly about it.

# INTRODUCTION

## REPORT STRUCTURE

### CURRENT SITUATION & SOLUTION

We will introduce the situation today, long-term illness, social isolation, and finally what is already being done about it. We will also introduce and analyze the AV1, a robot avatar from our project partner No Isolation.

### USER CONTEXT & RESEARCH

We will summarize our user research, and our understanding of the context in which the current solution is being used, and where our final proposal must exist. We will also introduce the basis for our proposal.

### TRENDS

It has been important to the development process to get an understanding of what is happening in the world of robots and social communications. We have summarized parts of our market research and field-mapping.

### CONCEPT DEVELOPMENT

We will go through our development and concept iterations based on our user and context research. We will explain the methods, steps and evaluations used during the concept phase and what we have taken with us in the final design proposal.

### DESIGN PROPOSAL

We will present our design proposal for a new robotic avatar. This is not a finalized product, but a concept that demonstrates how we think many of the problems facing the current product can be solved.

While we have not solved every detail, we see our proposal as a radical new direction in which to take the robot avatars of No Isolation, challenging most of the current conventions and solutions.

This diploma is a design proposal, we have had some focus points we have worked with and we have reflected around what could be the next step. We will go through these.

### REFLECTIONS & ACKNOWLEDGEMENTS

On the conclusion of this project and this report, we have some final reflections on what we have done, what worked, what didn't and what this has meant for us.

### REFERENCES





PICTURE The AV1, patiently waiting for its classmates.

# 2 CURRENT SITUATION & SOLUTION

IN THIS CHAPTER:

We will introduce the situation today, long-term illness, social isolation, and finally what is already being done about it. We will also introduce and analyze the AV1, a robot avatar from our project partner No Isolation.

# LONG-TERM ILLNESS

## SOCIAL ISOLATION & LONELINESS

**Many children and adolescents with long-term illnesses are unable to attend school, their most important social arena, for extended periods of time that can range from months to years and vary between occasional and total exclusion.**

Long term illness, or extended absence from an educational setting, prohibits children from taking part in a large part of their own education and everyday. This is often then accompanied by both social isolation and loneliness. (Bell, 2016; Best and Butler, 2014; Drachler et al., 2009; Roche and Tucker, 2003). Drachler reviewed thirty-two qualitative and quantitative studies, all including the views and needs of over 2500 patients suffering from ME/CFS and cancer, both long term illnesses largely prohibiting participation in everyday life. One major finding from the study was the need to support a way of maintaining and developing social participation and bonds. Furthermore, a stated finding was that "outside the family, education was the major focus of social participation for many young people" (Drachler et al., 2009).

Since long term illness prohibits participation in a regular educational setting, some reported having lost their connection with class friends and teachers. (Roche and Tucker, 2003).

All children in mandatory school age in Norway have a claim on home tuition if not able to participate in regular classroom activities. Drachler's findings point to that home tuition "allow a flexible schedule of learning within the limits of their condition, but reduced social participation at an important stage of social development" (Drachler et al., 2009).

Many associate social isolation with loneliness. But what does it really mean to be lonely? It is often referred to Perlman and Peplau (1981) definition of loneliness. They define loneliness as a negative emotion - **someone lonely is one who experiences that there is a discrepancy between desired and actual social contact.**

When we have a conversation there is a lot more to it than just saying words. We look each other in the eye, we take turns, we read facial expressions and body language, we pay attention to what our communication partner is paying attention to, and we stay on topic. We can read a lot from a person's tone of voice as well

"Social communication refers to language that is used in social situations"

Staying social is important to maintain a certain quality of life, but today we may ask ourselves: what is a social situation?

## LONG - TERM ILLNESS



"Many associate social isolation with loneliness. But what does it really mean to be lonely? It is often referred to Perlman and Peplau (1981) definition of loneliness. They define loneliness as a negative emotion - someone lonely is someone who experiences that there is a discrepancy between desired and actual social contact."

If not direct physical contact, there are many tools that help us communicate through other means. Today we have many communication tools and many of them right in our own pocket. From letter, fax, phone, social media to telepresence. How can we express emotions visually through these technologies? Tone of speech, facial expressions, emotions is one thing, but what about gestures or reading of body language?

The past few years have seen an explosive increase in the use of technology. Most people have a smartphone in their pocket at all times. We use many different channels to communicate via technology to stay social: From FaceTime, Skype, Video conferencing and SnapChat to Instagram and Messenger. How can the AV1 possibly compete with the existing solutions?

## CURRENT SITUATION & SOLUTION

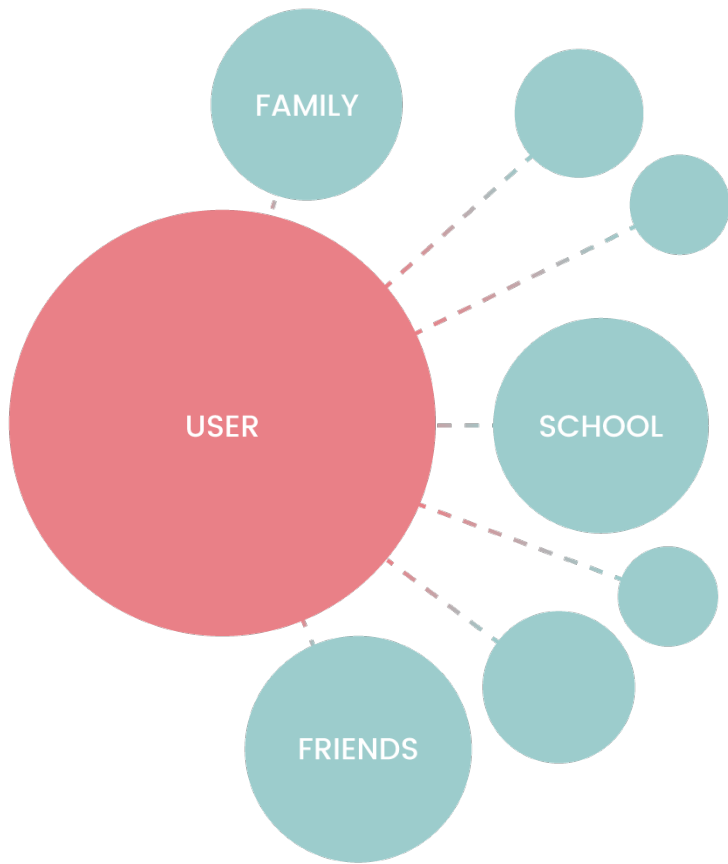

Every child has a large network with different relations; family, school, friends and so on. But if the child gets affected by a long term illness these relations gets a distance and the sick child gets isolated from its network. The network has no easy way of "patching" the lost connection. How can the connections be kept?

We have mapped out and analyzed different methods of maintaining these connections on the facing page. Most existing solutions face problems or challenges of some sort, making them unsuitable for certain situations, or unable to function as a whole.

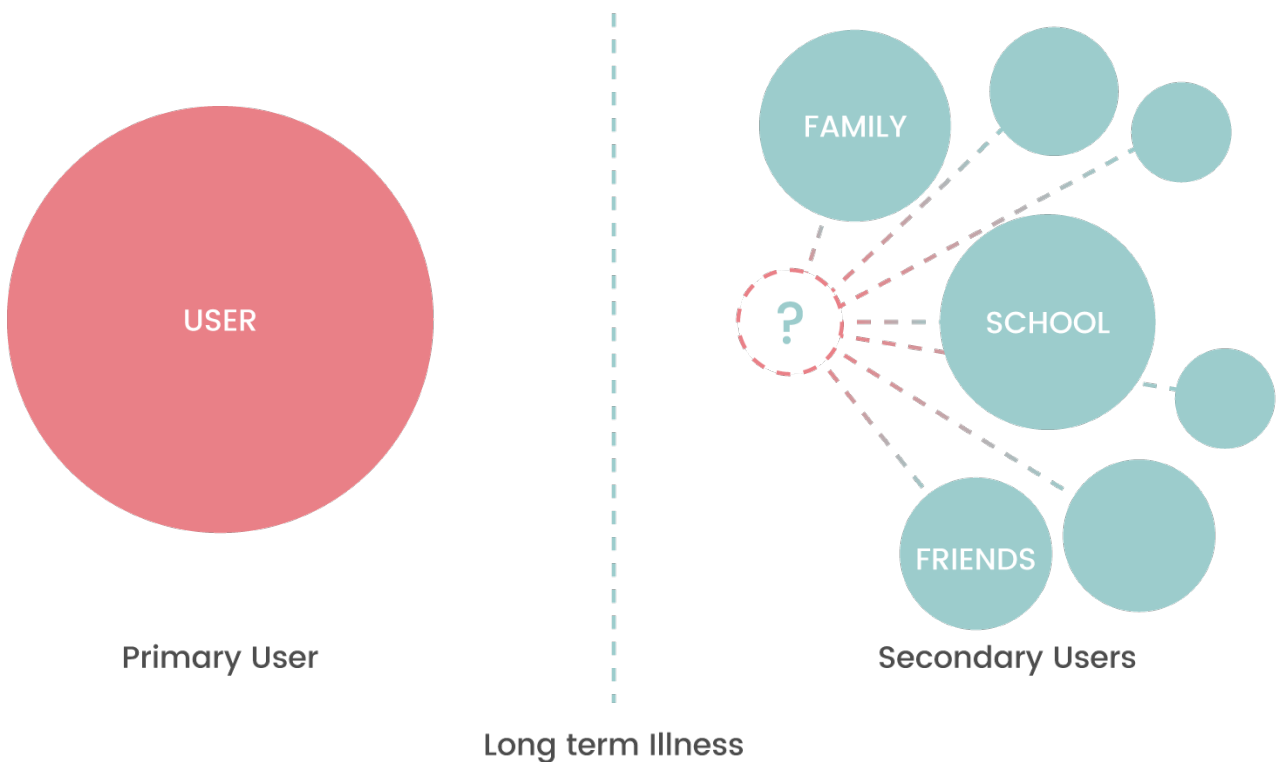



# LONG - T E R M I L L N E S S

## EXISTING SOLUTIONS

Existing and tried solutions to counteract social isolation and missed education.

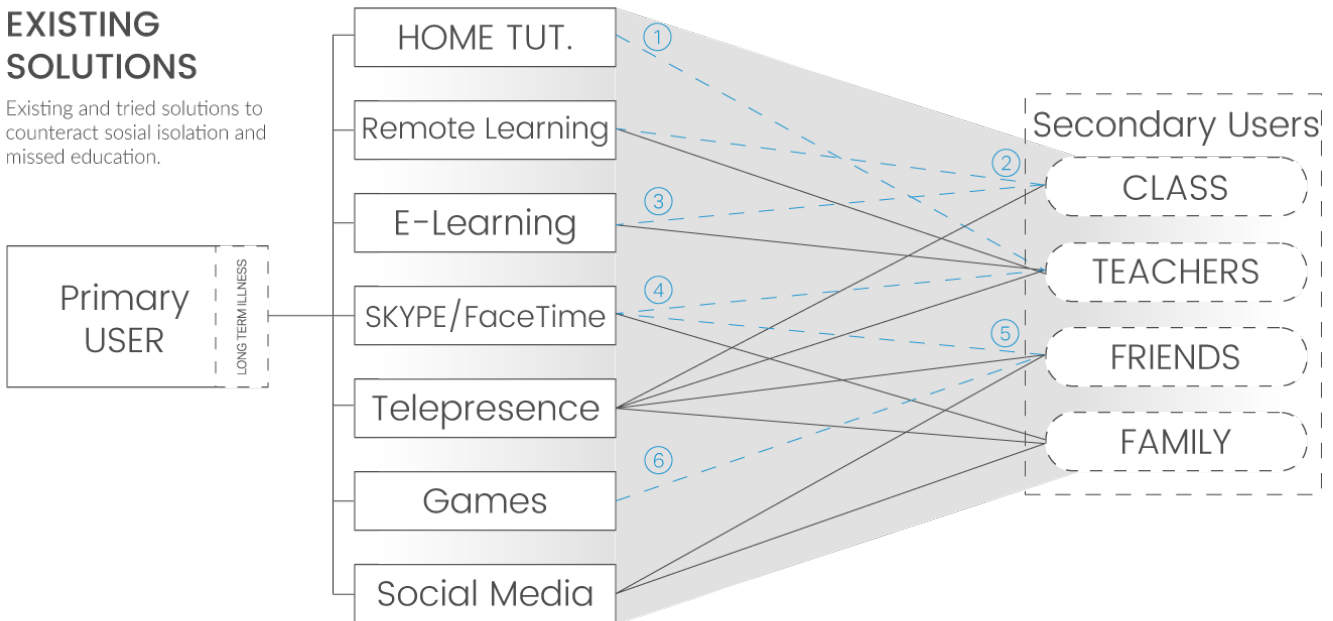

## CHALLENGES

1. Home tuition has to be planned and, therefore, often cannot provide the kind of flexibility needed. This results in the planned teachings often being canceled.

2. You can follow the classroom situation and the education, but it isolates you from the social part of school.

3. E-Learning (Frontier, Moodle, i.e) provides the possibility to follow along with the educational program, but not participate in class.

4. Traditional social communication tools often demand some degree of planning or scheduling. Like Home Tuition this often leads to canceling, or missed appointments. Also extra work.

5. S.C tools are not used like avatars. Before Avatar, friends did not include Skype, and after avatar they stopped including it. Easy to forget.

6. Games provide a social opportunity, but is incredibly hard to implement in a learning situation. All digital.

**The map above is a mapping done during the early phases of the project looking at what is being done today for isolated youths, and how they are being used.**

The map also takes into consideration challenges with the different solutions today, and what their weaknesses are.

There are many challenges in using any one of the solutions available, leading to either many of them being used at once, overwhelming the absent child, or none of them are used because they can't solve the issues that arise.

## CURRENT SITUATION & SOLUTION

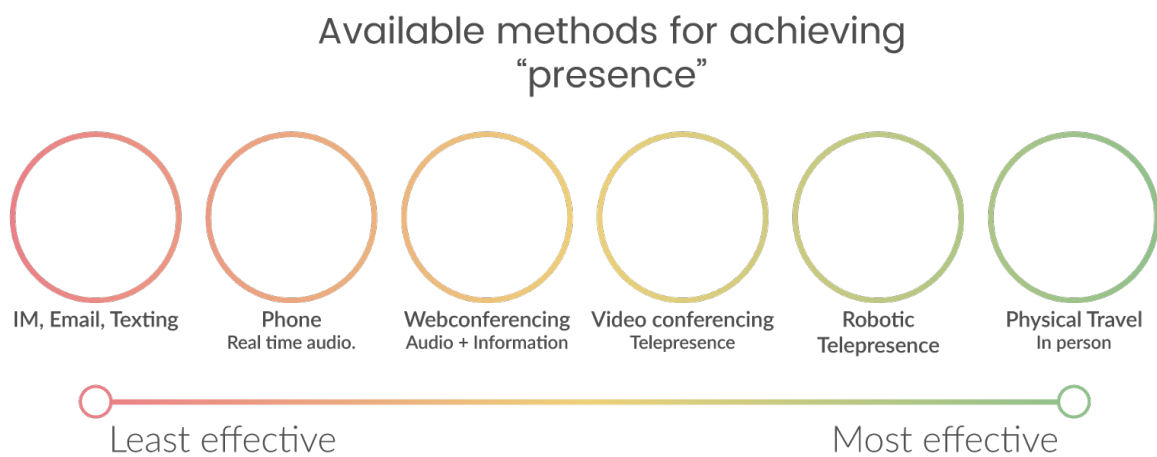

**Another part of the solution mapping can be seen above, mapping out the different methods for people to achieve presence, ranging from pure textual information, to physically going there.**

We have been comparing the AV1 to different types of social media and tools of communication throughout the project. The AV1 being a robotic telepresence-unit, it ranks highly on the effectiveness-scale seen above, and therefore an interesting product to do a diploma project on.

## LONG - TERM ILLNESS



"Whatever little social interaction they can get, it's better than nothing! It must be ok to be sick, but want to, and be able to participate in your own education."

# AV1

## EXISTING SOLUTION

**Our original introduction to this project was through the existing solution from No Isolation, the AV1.**

The AV1 is a small humanoid robot that stands approximately 27 cm tall. Inside the body of the robot, it houses all the necessary electronics, a camera, speakers, a microphone, a battery and a motor that enables 360-degree rotation at the base, as well as a 40-degree up and down head movement. It weighs approximately 1 kg including everything. The physical shape of the AV1 is meant to invite classmates to easily pick the avatar up and carry it to places such as the schoolyard during breaks or on class excursions so that the user can participate in extracurricular activities along with friends. An integrated 4G connection intends to enable the avatar's use everywhere.

The user controls the avatar remotely, in real time, via the accompanying app installed on a personal smart device, such as a smartphone or a tablet. Through the app the user can turn the robot on, look around through the movement and rotating of the avatar's movements, and communicate with teachers, friends and family on the receiving side.

Of important notice is the fact that the AV1 only streams data directly from the classroom, and this data is encrypted both on the way out from AV1 and when received on your phone / tablet. It is also impossible to record or store video through either additional application or screenshots (in iOS, we can not prevent ▶

TECHNICAL SPECS  
NO ISOLATION AV1

- WEIGHT - ABOUT 1 KG
- DIMENSIONS - 26.8 CM X 17.5 CM X 12.9 CM
- BATTERY - ABOUT 1 SCHOOL DAY OF USE (8 HOURS)
- CAMERA - 13 MP, 77.6 DEGREES ANGLE, AUTOFOCUS, 360 DEGREES ROTATION, 40 DEGREES UP / DOWN
- AUDIO - SPEAKERS WITH CLEAR SOUND FOR VOICE
- CONNECTION - WI-FI AND 4G BUILT-IN
- TWO AXIS OF MOVEMENT, HORIZONTAL & VERTICAL CAMERA MOVEMENT.
- CHASSIS MADE FROM INJECTION MOLDED PLASTIC
- ONLY AVAILABLE IN WHITE.

# AV1



"AV1 is indeed no replacement for human connections, - it's more of a facilitator for communication."  
- *No Isolation*

## CURRENT SITUATION & SOLUTION

screenshots, but an automatic e-mail is sent to the user who took the picture with a warning that the connection with the AV1 will be terminated if it happens again)

To secure the students on the robot-end of the connection from surveillance, the user logs on with the application through a personal identification. They must create a personal password and confirm that only he / she will have access to the password and application the first time they access the app. A guardian must

also approve that only the user him/herself will be able to connect to AV1 before being granted access. A guardian logging on with the AV1 is therefore a breach of contract, leading to termination of the agreement.

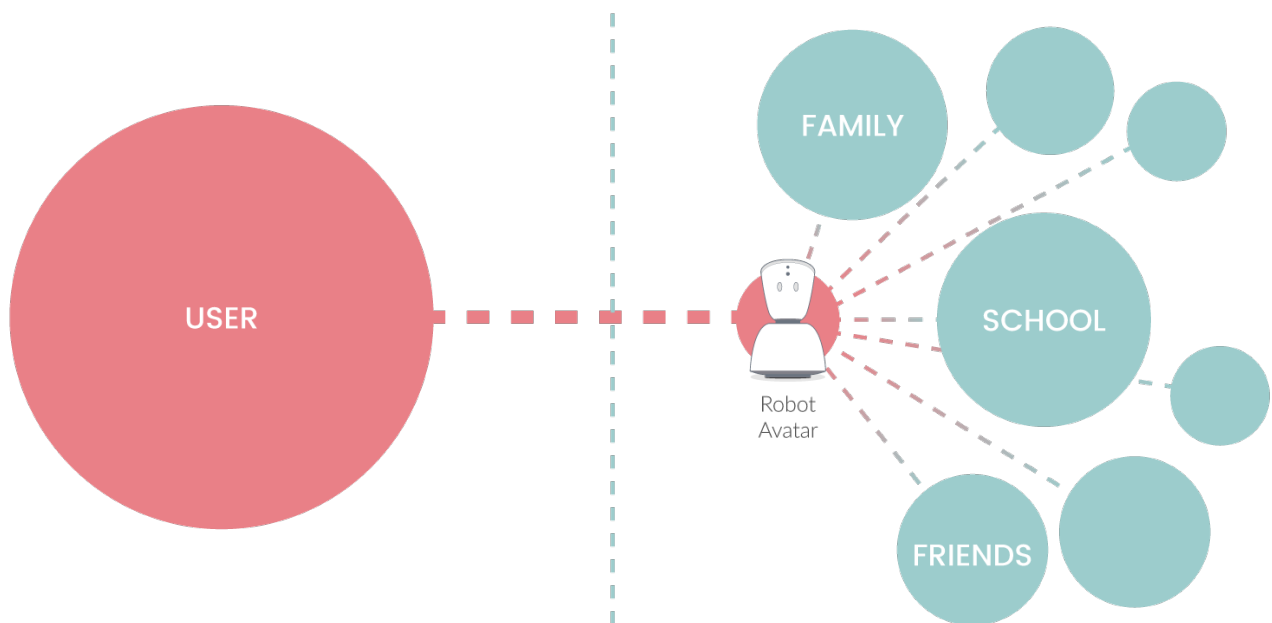

AV1 is a communication tool and a representation of the user where the user normally would be physically present now controlled over distance keeping the connections intact.

# AV1

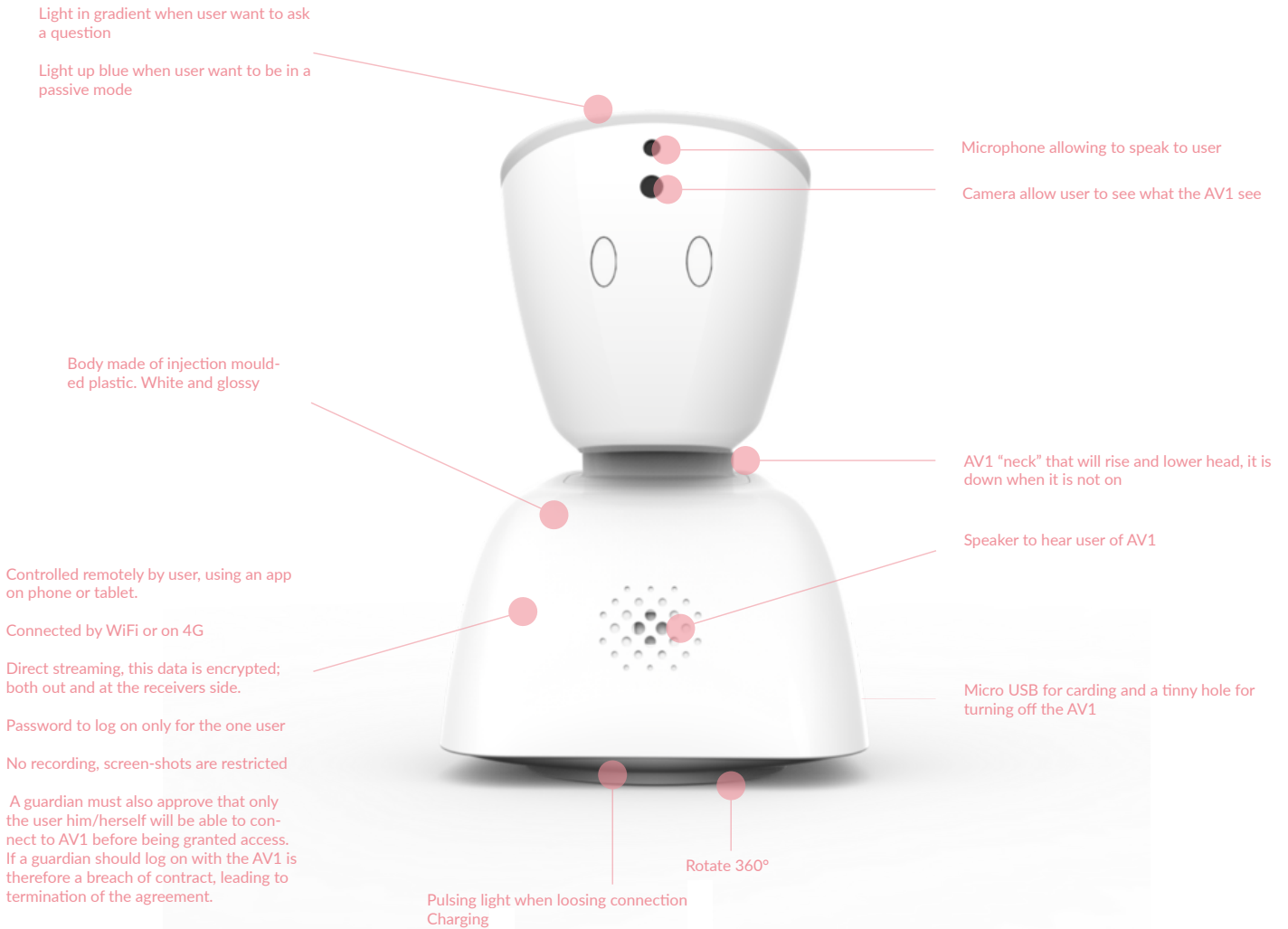



## CURRENT SITUATION & SOLUTION

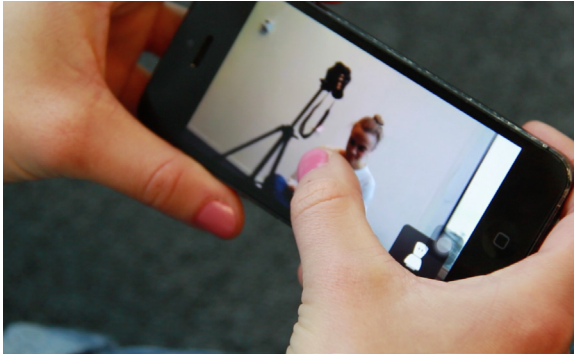

**TOP LEFT** AV1 is controlled from an app on your iPhone.

**LEFT** Handy size makes for easy transport, even for small hands.

**RIGHT** Located at a student's desk, the AV1 sees all.

Waiting patiently for the rest of the class to show up.

Although the sick children are the focus and the **primary users** of the AV1, we have chosen to work with the **secondary user**, the ones interacting with the avatar.

Through our research we have read about the primary users. Based upon the users we have read about, we have created these three typical users; Lucas, Lisa and Erik.

These fictional users helped us understand how the relationships they have connect, and gave us an idea of how a typical use of an avatar could be for them.

We have also mapped out how the AV1 can be acquired, understanding the price and market of the AV1.

# AV1

## NORGE

6000 empty school desks in Norway due to long term illness



Response to current situation.

### PRIMARY USERS

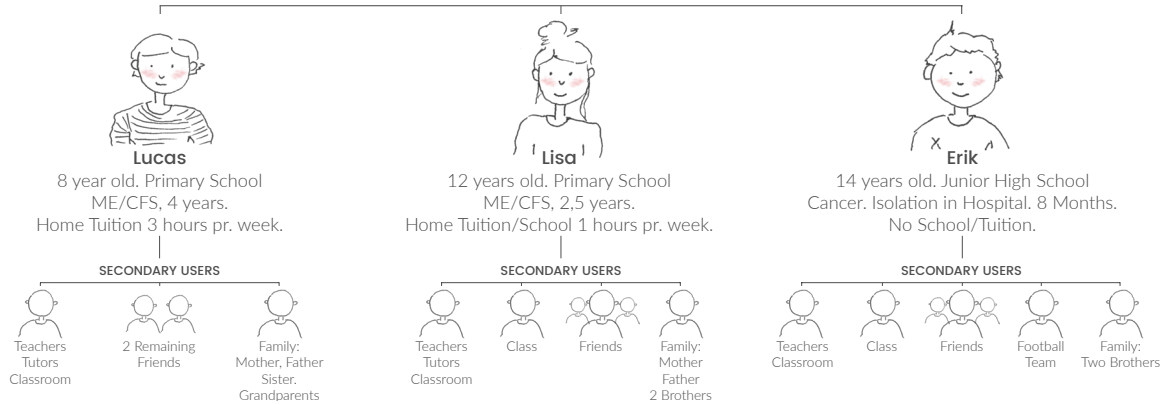

## ACQUIRING AN AV1

There are as of today 3 ways of acquiring an AV1 from No Isolation

### ORDER AS PRIVATE ACTOR

Parent/Users themselves

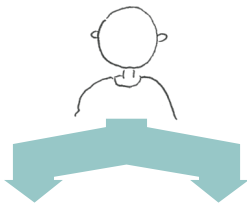

Long Term Rent	Short Term Rent
----------------	-----------------

18.900,- /Year (1.575,- /Month)	2.990,- /Month
Telia 4G Subscription	Telia 4G Subscription
Full support	Full support
App	App
Insurance	Insurance
Automatic updates	Automatic updates
1 year Minimum	No Minimum

### ORDER AS SCHOOL/MUNICIPALITY

Individual schools or larger municipalities



BUY

Retail through Atea  
24.000,- /AV1  
Support & 4G sub.  
12.000,- /year, 3Years  
Full Support  
App  
Insurance  
Automatic Updates

### ORDER AS GIFT

Funds, Organizations, Interest Groups etc.



Case-based deal

No Isolation actively pursues collaborations and agreements with various organizations, companies and foundations to gift AV1s to children in need.

# MEDIA

## SOCIAL ISOLATION & LONELINESS

The media coverage of the AV1 has been very heavy throughout our project period. Primarily in Norway, but towards the final months of the projects it spread to other European countries. The media coverage gave us an impression of how the AV1 is used. We have selected some screenshots from different commercials and articles published that served as indicators for us in the early stage of this diploma.

**No Isolation is a collaborating partner with Telia, who delivers the 4G for the AV1. Telia made one of their movies in their Telia Stories commercials on the AV1 and have been heavy publicizing it for the last year. On these pages some screenshots from that and some other videos on the AV1 published on the internet.**

Looking at these videos we felt that the AV1 is a very strong concept (there is no question that these commercials sell it very successfully). We were however asking ourselves: How does it really feel when you have it in your hands? How do you carry it? How is it to give your friend a hug? Are you really able to bring out on a camping trip, and can you really notice the different indications it expresses, like you can in a classroom?

The promoting of the AV1 tells you that this will allow your sick child to go everywhere, it will allow you to take part in education but also the fun play in recess. To join in on a stroll down the street and catch up with your friends. We were interested to see how this really worked out in real life.

How are the varieties in expression, sitting in a birthday party, should you be able to smile? The primary user is the one who logs on and decides for itself when to participate, there is no way for the secondary user to let the absent child know they're missing out on a funny joke, could there be a way to contact the absent child?





# MEDIA COVERAGE



Hvis det skjer noe ute som klassen min tror er  
gøy for meg, kan de ta med meg ut.



# PUBLIC DISCOURSE

## TODAY'S RELEVANCE

When it comes to the public discourse around the AV1, there is no surprise its a discourse of diversity where doubters, dreamers and experts has revealed their worries and hope for bringing a robot such as AV1 into classrooms. Discussions about the ethics of letting a robot represent a child has been an essential part of our work. While following the ongoing debates in the media, the two of us have continued discussing and also debated some «core issues» with experts within the field and users of the robot.

In the Norwegian A-Magasinet you can read about how the AV1 is helping Eirik (10) with staying connected with friends and keep up in school while he is away on training, due to the illness of cerebral palsy. Norway's biggest Broadcasting company (NRK) has told the story of Emma (10) whom suffered acute liver failure, and had to be brought into surgery. Today, Emma is healthy, but the intervention means that she can not be exposed to infectious disease, and she can not participate in regular classroom education. AV1 helps her to participate in the teaching while staying home. These are two important stories, both telling the positive aspects of the new robot on the market.

But as mentioned earlier, not all the media coverage has been exclusively positive. The Norwegian news paper «Dagbladet» has been the arena for a rather critical debate.

Edith Nybakk, a mother and teacher, shared her critical views of using robots in schools. The title of her article was the following: «Should we allow video surveillance in the Norwegian school?». Edith argues around the topic of using sick or disabled children for allowing surveillance. She then argues strongly how there are warning signs and information signs when surveillance cameras are placed in the public sphere.

Nybakk's article is lifting important questions, but somehow the appearance of her opinions can be interpreted as oblivion opinions from a sceptical parent that might not have as much knowledge about the use of the AV1. However these worries are real worries for her, as a user, and that's a part of the debate that is important to take seriously to understand how the product can become better and less frightening. For instant, Nybakk mentions how we can know whom sits on the other side, looking at the children in the classroom;

«I find it interesting that the outside world should have a peek hole in which students will try and fail, be educated and formed.» This is a question we have seen a lot in the critical articles.

The answer to this debate came from Anna Holm Heide, from «No Isolation», answering: «The robot AV1 is a window into a classroom for a student who belongs there initially.»

From this debate, we see how some people are sceptical of letting what they compare to be a «surveillance camera» into classrooms, the scepticism from Nybakk's article. But after deep researching and getting to know the background and effort put into the AV1, its clear that AV1 is a product with a vision of combining technology and presence to the better for these children's everyday life. The challenge is to make most people accept AV1 as a helper, and not an intruder. And to do that, the critical questions of the debate has to be taken serious so that the two opposite sides can meet each other - and find a solution.

As a fresh and new product, the AV1 is getting both the positive and negative attention, its important to be sceptical and critical to technology, especially in us together with children, but we can also see the great opportunities it can give to these children. To be limited by scepticism is not a solution.



**FILMER:** Roboten AV1 skal gjøre det mulig for syke barn å være tilstede på skolen. Roboten streamer lyd og bilde fra klasserommet, og styres via en app. – Jeg finner det betenkelig at verden utenfor skal ha et kikkhull inn til der elever skal få prøve og feile, undannes og dannes, skriver innleggsgjortfateren. Foto: Tore Meek / NTB Scapix

Debat: Robot

## Skal vi tillate videoovervåking i norske skoler?

Det viser seg av robotene er i ferd med å infiltrere norske klasserom lenger før de som burde ha en prinsipiell holdning til saken har rukket å komme på banen.

**MENINGER** 1. FEBRUAR 2017 KL. 6.00 [DEL PÅ FACEBOOK](#)

Av Edith Nybakk, mor og lærer

**I høst er gang** dumpet jeg borti fjermsynsklassen som omhandlet roboten AV1, som skulle inn i klasserommene som støttforbeder for elever med langtidssykdom. Hadde datoen vært 1. april, hadde jeg klart vurdert dette som en spøk. Men nei, det. Det viser seg at robotene er i ferd med å infiltrere norske klasserom, lenger før skoleledere, skolefaglige ansvarlige, fagforeninger, fylkesmann og andre som burde ha en prinsipiell holdning til saken, har rukket å komme på banen.

**Dette drøler seg** om markedsførere i friluftsliv. Grunnen bak roboten har vært seg motivere av et opp til 6000 skolebarn årlig har nye sykkefraver. Det hevdet at motivet er å hjelpe.

Jeg ser det slik at kreftene bak denne oppfinnelsen ikke holder seg for gode til å skyve en langtidssykt eller handikapet barn foran seg i debatten om hvorvidt overvåking i skolen skal være tillatt eller ei. Så får heller foreldre og lærere som ser galskapen i dette, ta «barnen» med å framstå som hjertelese.



**BKOPTISK:** Edith Nybakk, mor og lærer.



**Du kan vinne vanvittige 390 millioner**

**ANNONSBRINNHOLD** **FRA NORSK** **TIPPING**

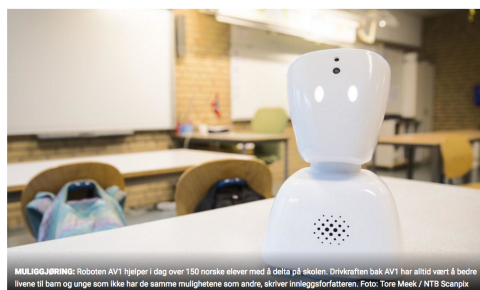

**MULIGGJØRING:** Roboten AV1 hjelper i dag over 150 norske elever med å delta på skolen. Drivkraften bak AV1 har alltid vært å bedre livene til barn og unge som ikke har de samme mulighetene som andre, skriver innleggsgjortfateren. Foto: Tore Meek / NTB Scapix

Debat: Teknologi

## Robot hjelper over 150 barn å delta i skolen

Roboten AV1 er et vindu inn i et klasserom for en elev som hører hjemme der i utgangspunktet.

**MENINGER** 6. FEBRUAR 2017 KL. 6.00 [DEL PÅ FACEBOOK](#)

Av Anna Holm-Heide, No Isolation

**I sin kronikk 1. februar uttrykker** Edith Nybakk engstelse for hvorvidt «overvåkings»-roboten AV1 utvirket skal «infiltrere» norske klasserom. Dette utspisnet, samt en rekke andre, er påstander som ikke kan stå uimotsagt. Vi forstår bekymringene til Nybakk, men har tatt høyde for samtlige under utviklingen av AV1. Hvis er det mot det nye, ukjente, som vekker en slik negativ holdning, og særlig når det kommer til teknologi?

**Motivasjonen for å** lage AV1 kom i 2015, og hadde ingenting med penger å gjøre. En venninne av Karen (grunnet) som var sykepleier fortalte henne om isolasjonen barn på sykehus lever i, og hvor ensomt det var for dem. Som den oppfinnere hun er, begynte Karen umiddelbart å tenke på løsninger for dette. Alle barna og foreldrene hun snakket med sa det samme: De ville være på skolen. Det var der vennene var, det var der de egentlig skulle vært.



**INNLEGGSFORFATTER:** Anna Holm-Heide, No Isolation.

Med bakgrunn som programmerer og UX-designer tenkte Karen at man måtte kombinere teknologi og tilstedeværelse. Resultatet ble AV1 – en robot som i dag hjelper over 150 norske barn med å delta på skolen. Drivkraften bak AV1 har alltid vært å bedre livene til barn og



**Du kan vinne vanvittige 390 millioner**

**ANNONSBRINNHOLD** **FRA NORSK** **TIPPING**

## Emma (10) fekk uventa robothjelp

LOM (NRK): Siste dag for sommerferien fekk Emma skutt leversvikt og måtte haldast borte frå skulen. Då fekk jo hjelp frå ein kvitt robot.



**GLADTENE:** Emma Randen Bergheim smiler og er glad for at ho fikk gjøp av undervisnings, sjuv og ho var borte frå skulen. Det er ingen mening en robot for. Her er ho saman med mor si, Lene Randen Bergheim. FOTO: EIVEN LUSÅTER / NRK

Pulten til Emma Randen Bergheim på Lær skule i Lom har stått tom sidan skulestart i haust – likevel gje ho kjøp gjøp av undervisning.

For på pulten hennar står det no ein 30 centimeter høg robot, med blinkende auge og ein heglar på magen.

– Du blinker med auge om du vil meg roke? spør lærer Grethe Aurno.

Gjennom roboten kan Emma sjå heime og fylgje undervisninga frå mobiltelefonen sin.

– Ja, svarer tilrådingen som sit heime og skriv stl.



**BLIKKFOR:** Såv ein robot som gjer at Emma kan fylgje med på undervisninga sjølv om ho kjøp er på skulen. Ho er 30 centimeter høg, og har blinkande grønt lys. Lysen sjølv er ho heglaren på magen. FOTO: EIVEN LUSÅTER / NRK

### Må haldast borte frå skulen

Før ferien fekk Emma skutt leversvikt og måtte rett inn i operasjon. I dag er Emma frisk og reisk, men innspisnet gjer at ho kjøp kan utsett for smittet, og ofte kjøp ta del i vanleg klasseundervisning.

### AV1



FOTO: EIVEN LUSÅTER / NRK

AV1 er en 28 cm høy «støttrobot».

Den veier ca. 40 kilo og kan tes med overblikk.

Klassens lærer og miljøvern sørger for at langtidssyke elever kan få være tilstede i klasserommet og holde kontakt med venner.

AV1 styres med en app fra en telefon eller et nettbrett.

Blått lys i øyne med innelevert batteri 2016.

Dette første halvåret har ca. 150 barn fått tilbud om å bruke AV1.



FOTO: EIVEN LUSÅTER / NRK

### Theodor og klassekameratene

viser fram: det får beholde skulen sin

Hjelpemiddel



## Eiriks lille hjelper

Atte uker i året fortaler Eirik Sander Viken (10) skolen for å trene på å få sin kontroll over kroppen sin. Du overtar av robot plussen hans i klasserommet.

FOTO: SØSK PETER/NTB

Forbedring i tilgjengelighet kan bli en fordel for elever med kroniske smerter. Med roboten kan Eirik følge dem hver dag.



# PERCEIVED CHALLENGES

The AV1 faces many challenges when it comes to its intended use. Through an extensive user research and our own analysis, we found several possibilities for improvements in today's solution that will have to be implemented for the concept to work as intended. On these two pages you can read some of our early thoughts on the AV1 based on our first hand experiences with it.



## INFORMATION LIGHT BOTTOM

The AV1 has two indicator lights in the lower front. These lights indicate different types of information.

- Due to a multitude of similar indication, the users have to consult the user manual to understand the different meanings.
- The light can for example indicate battery levels:
- Bad battery showed by intense pulsing light high speed,
- Fully charged showed by light stop lighting up
- Sleep-mode, pulsing light in normal speed.

## INFORMATION LIGHT HEAD

The head has color-coded/patterned lights

- Red cross indicates non reception
- Orange strip: 2G-reception (1 indicates low reception, 4 indicates high).
- Blue strip: 3G-reception (1 indicates low reception, 4 indicates high).
- Green strip: 4G-reception (1 indicates low reception, 4 indicates high).
- White strip: WiFi connection by 4 lights. If all lights are white, this indicates participation mode

- Blue lights over entire head, indicates a passive mode where the sick child spectates through the robot, but does not want to actively engage in the classroom activities.
- White pulsating waves from back to front of head indicate that the user has a question/wants attention.

## THE LIGHTS

All the lights are hard to see in broad daylight or a bright room. The head especially is very hard to see, and ends up not giving the information needed to the users. Are all the different signals necessary? We have to look meanings up in the manual for every single one.

## THE MATERIALS

The outer shell of the AV1 is made from white and opaque injection molded plastic. We asked ourselves "Why?" That it is easy to clean is the most obvious, Injection molded plastic can also be cheap. A big question we had is how does it feel next to the body or in a child's hands, and how does white plastic promote its intended use? Can it fall down from a desk or stand up to the rigors of a tent-trip? From our user research we also found the users to be hesitant to bring the avatar with them, for fear of it breaking due to brittle plastic.



## PERCEIVED PROBLEMS

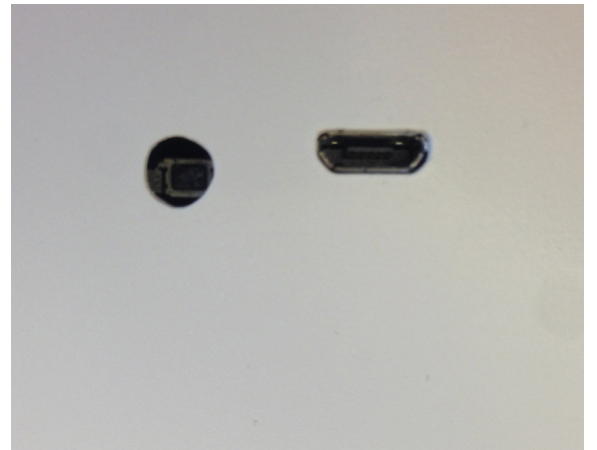

### SHAPING/PRODUCTION

The outer shape of the AV1 follows the major function, "covering" the internal technology. Many of the practical functions therefore influence the outer visual greatly. Things like holes for cameras, speaker-mesh and visible joints are obvious all over the body of the avatar.

On the bottom of the avatar the rotation disc is clearly visible, the neck is open into the head where it allows it to look up and down. Can these be weaknesses in its use? Can for example sand or dirt slip into the body through the large opening.

### -BRING YOUR FRIEND

The AV1 is an avatar of your friend you can bring with you to the math-class or out on a trip to the forest. One of our major concerns were how do you actually do so? It fits perfectly in a backpack with the size it is now, but where is the natural holding point for your hand? For us the neck was the natural holding point, where our hand stays steady, letting us grip it tightly due to it being the only place on the robot you can reach around. However we where instructed to not do so, since this is a weak point in the structure, and the plastic gears in the neck can break if it's held like this while the head moves.

### CHARGING

To charge the AV1, the users need to plug a Micro-Usb in the back of the machine, much like a smartphone. The operation in itself is natural for most of us, but unlike a smartphone, the avatar can rotate on its own. The charging wire can then get tangled in the robot, resulting in it falling over, breaking or other unwanted results. Later in our user research, we also found that users often forget to charge it between uses, resulting in the use being disrupted.

### ON/OFF

No Isolation claims that there is no reason to turn the robot off other than flying. To enforce this view, the on/off button is hidden inside a small access port on the lower back of the AV1. To access it, you will need a small tool to help you press the button. This makes it very unavailable for users, preventing them from turning the robot off, but we also found quite early that it also prevents them from easily turning the avatar ON again after it runs out of battery, or if it has shut down due to certain required circumstances.





PICTURE Birk testing the AV1.

# 3

## USER & CONTEXT RESEARCH

IN THIS CHAPTER:

We will summarize our user research, and our understanding of the context in which the current solution is being used, and where our proposal must exist.

We will also introduce the basis for our proposal.

# JORUN & ALMA

Today, the largest user group of AV1 are ME-ill children and young adults. Looking at how these children use and relate to the existing solution was therefore a natural starting point for the project. Both because they are a large user-group, but also because the symptoms of ME are largely shared with many other serious illnesses and are therefore a good indicator of what other users would need.

For this diploma the user group is divided into two groups; the primary user: the sick child, and the secondary users: the people interacting with the avatar; The secondary users are our chosen focus in this diploma.

Even though our focus has been the secondary users, we still needed to get an understanding of the needs and wants of the primary user. Early on we faced challenges meeting the primary users due to the fact that we are working with sick children. We have come up against a lot of red tape and bureaucratic hindrances, but also the concern that we would be in danger of worsening their health. To solve the challenges

of primary user research, we contacted two researchers from the University of Oslo.

Jorun Børsting and Alma Leora Culén at the Department of Informatics at the University of Oslo, are for Joruns PHD researching the technology needs of children and young adult with ME.

Jorun has organized and researched the use of AV1 by 9 ME-ill children and young adults since the AV1 prototype stage in 2015.

Much of the data we have based our understanding of the primary user and their needs, is from the research done by Jorun and Alma and our meetings and discussions with them. We have had a great relationship and have the privilege of getting to base our project on some of Jorun and Almas work. Allowing us to quickly gain insights into how the main users, the sick children deal with the AV1, and what their needs and views are.

J&A were very positive towards the AV1, and found it very interesting since there has been very little research on technology in use for these patients and there are many needs and

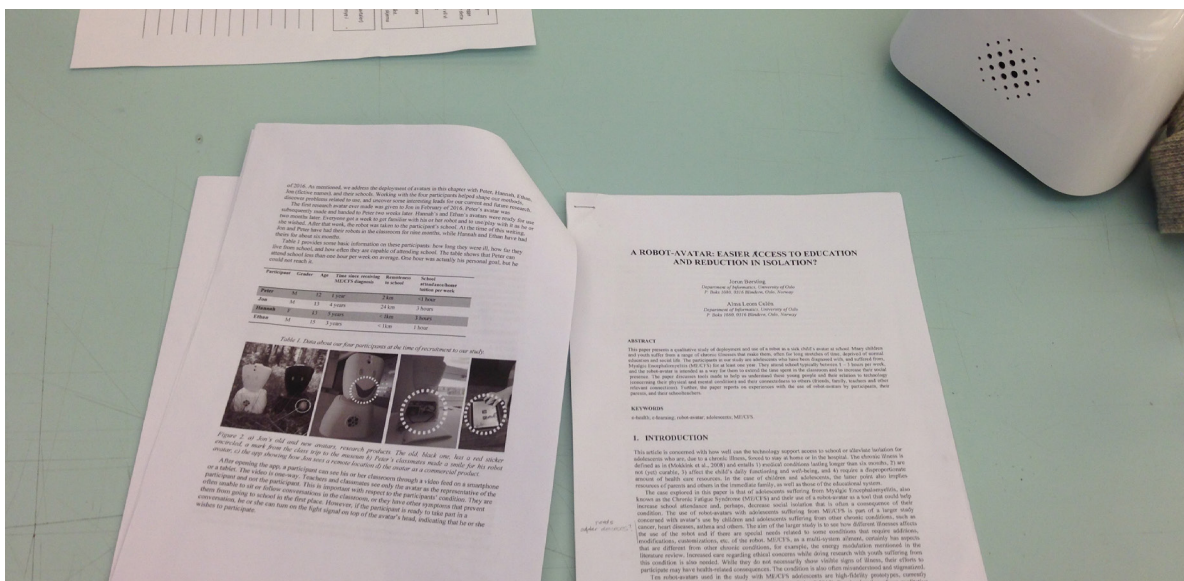



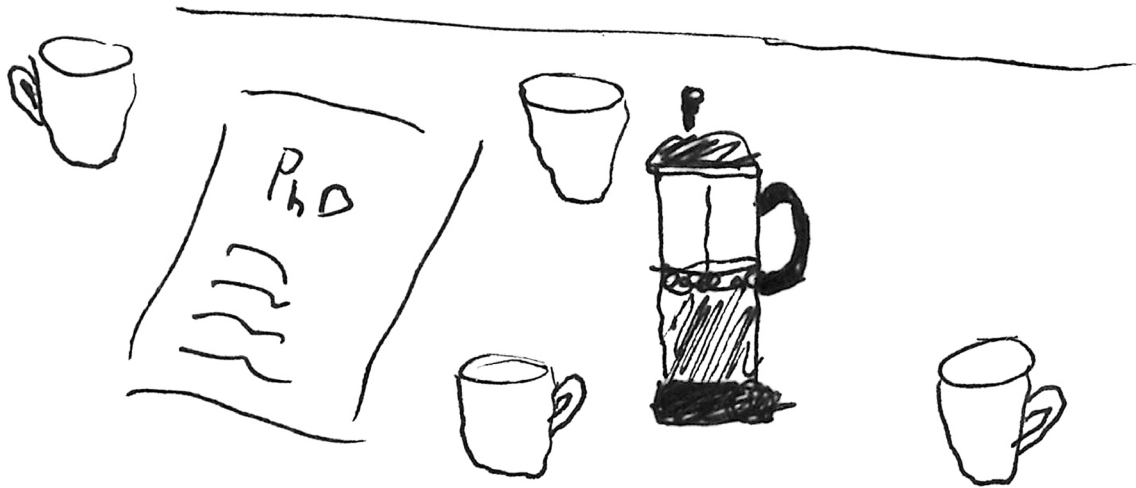

wishes that need to be fulfilled.

With today's increase in children suffering from ME/CFS you see the importance of not getting a large gap in their education, and using technology as an aid can really help.

As student in Norway you can demand home tutoring, but this often gets canceled due to health being unpredictable and hard to plan in advance, so to have the freedom to join when the health is good is a wanted solution. This is a solution the AV1 provides.

AV1 allows the user to show a passive or active mood in class, this is necessary, to be participating passively and on the other hand participate actively when they feel like it; all of this not too worsen the health of the primary user. The teacher has to be able to read these moods of participation and interact with the avatar according to these moods..

The primary users also have an expressed wish to stay connected on a social level, not just educational, to feel less isolated.

The setting the AV1 operates in demands user-friendly solutions. It's "Put away in a closet if not!" to quote Jorun. The concept exists in a Social and Educational setting to prevent social isolation and loneliness. The robot avatar will need

to fit into these situations to be used as intended. We have conducted our research within these arenas, both educational and social. The primary users also have an expressed wish to stay connected on a social level, not just educational, to feel less isolated.

"These people are not away from school because of laziness. They would go and participate if they could but that's not possible. There is nothing they want more than to participate in a regular day."

**LEFT** We were given access to parts of Joruns PHD

**ABOVE** We were not allowed to photograph during the interviews, but we could sketch.

# RUSELØKKA SKOLE

## CONTEXTUAL RESEARCH

For us to gain solid research to build our project on, we wanted to make use of Tea's background in social anthropology.

Anthropology is in a short sum up; to study humanity as a species and as a social being, in an overall and comparative perspective. Anthropological method is based on the fact that people often say one thing and do something else and therefore explanations have to grow out of Anthropologist's "stay" among the people he or she investigates; fieldwork.

We have used qualitative methods in use such as observation, participant observation and informal interviews. By doing this we could gain a broad insight into the user behavior and habits - something that is difficult or impossible reproduced verbally, even if a subject is questioned directly about it.

We visited Ruseløkka school where we observed a class of 7th graders for a day. We did observations on both the students and the teacher. Drawing up the traffic in the room, looking at the interaction between the students and the teacher and between the students.

We also observed during their lunch breaks and recesses to see all the different activities, not only from the 7th grade but the whole school. This was valuable for us to get an understanding of a regular school day and what would face the avatar in its habitat.

We observed a lot of different social behaviors. The moment we entered the classroom were we met with high fives, and great interest, seeking of contact and attention. We saw the same traits in the interaction between the students too, working together, or helping each other out with their assignments, noticing each other and involving each other. Our primary finding is just how important it is to be able to be included and seen, both in the social aspect, and in work.

These small interactions are what makes you feel like you belong.



**THIS PAGE** Recess, all the kids from 6 - 12 together outside playing. Teachers in reflex vests make sure everything is good with everyone.

Classroom setting, blackboard the teachers desk in front corner and students desks placed 2 and 2 together.

# RUSELØKKA SKOLE



**THIS PAGE** Recess showing the variety of activities. From football, to playing tag, to hanging out on a bench.

A classroom filled with student, eager to catch each other's and the teacher's attention.

We noticed the note on the door saying "At Ruseløkka School all the students raise their hand when they have something they want to say".

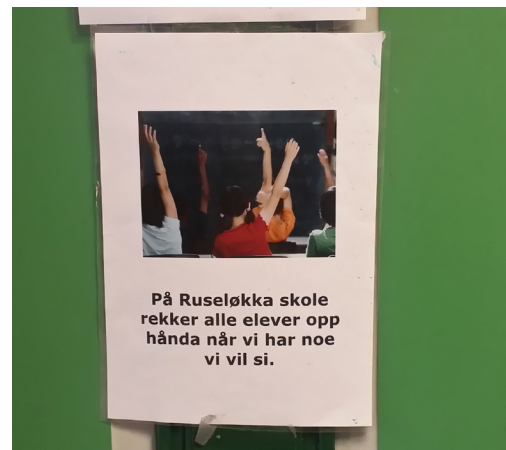



# EXPERT INTERVIEWS AT JONG & MØLLADAMMEN



To get an indepth understanding of how the current solution, AV1, performs in a classroom, we set up meetings with two schools; the first generation adopters of the AV1 in Norway, together with Simon from No Isolation. The two schools have used/tried to use the AV1.

## Jong Elementary School

Meeting with Lene Nakstad - Section leader 3.- 7.grade  
Situation: Sick child from the 3rd to the 7th grade.  
A child being little bit to and fro over 5 years.  
At Jong, they had gotten the AV1 to work once, while on a school trip to Hallingdal. Very uplifting experience for the child. Used around the campfire "just like in the commercial!" according to one teacher. This was the only time it was in use properly, The teacher would set

it up every morning but due to circumstances on the sick child's end it wasn't used more, and sometimes also because of bad reception(technical issue now sorted with WiFi along with 4G).

## Mølladammen High School

Meeting with Finn Even Smith - Leader 10th Grader  
Situation: Student with ME. Student being to and fro school for the 2 years. Parents got in touch with the school to figure out a use or the possibility of using a AV1 for their son. Trial period of a month.  
School owns the AV1. Sadly not being used much because of bad reception.

They had tried other use of communication technology like Facetime and Skype, that had not worked at all

**ABOVE** Tea and Simon  
outside Jong School.

**RIGHT** Mølladammen  
School



as this needed a higher engagement from both the student and teacher to keep a strict schedule. Here they saw the benefit of AV1, where the student logs on whenever he/she want to, without having to make prior arrangements with the teacher. The size of it also made it visible in a different, better way than a pc/ phone,.

Both schools said it should be a product covered by NAV or Hjelpemiddelsentralen. Because it costs a large sum of money, and is hard to implement from the municipal side. If the school buys the AV1, and it is a success and works very well, what happens if the need for more than one robot arises? The school cannot afford more than one or two. And if it's going to be used as promoted it's too fragile for them to dare do this, as expressed by Lene during our meeting.

Finn Even said it would only be used in one specific classroom, not "on a canoe trip" like in the commercials, only in select classes. Would not initially be moved from classroom to classroom along with the other students, but this might change over time. Maybe it would become something the friends of the students took care of, but maybe not? "Change in use would evolve organically" but starting out simple.

From meeting these two schools our motivation grew. They were very engaged in their students and their wellbeing and saw the AV1 as a great help to give their students better lives. The key thing we brought with

us, the portability/size, readability of mood/reception/ battery, and the shape for its intended use.

"Bridge between technology and relationships." - Finn Even

"I think he won't feel that the gap (between him and the other students.) is as big when he comes back." - Lene



# INTERVIEW WITH TEACHERS



After meeting with different users included to our project and getting a grip of what areas we saw as possibilities for development we did an in debt interview with three teachers, validating many of our own findings. We had prepared several key questions to ask our teachers, letting them fill in the blanks as much or as little as they wanted. Much of the information gained was from Heidi Østensen, who from years of experience as a teacher of all age groups had many interesting and valuable thoughts.

A lot of the answers from these interviews corresponded with our own experiences from our observations at Ruseløkka and at Akademiet.

Heidi focused on how she reads a student in a class. By reading the body language, following the eyes, listening for certain tones of voice, and constantly actively engaging different students by focusing on how each student could perform the best according to their ability, she worked closely with the students to create as good a classroom experience for everyone as possible.

Heidi also focused greatly on something we had seen at Ruseløkka, the "læringspartner" (co-working partner) system. She believes enabling being included in this very important part of class life gives the primary user a much larger sense of belonging than just being able to talk to the teacher.

**RIGHT** Tea getting ready for an interview.

# KEY RESEARCH INSIGHTS

From our user & context research we brought several key insights with us to the concept development.

**The stronger the emotional connection with the avatar as a representative of the child, the better outcomes can be expected from its use in terms of social connections.**

- 1 The emotional aspect that physical representation of a child by avatar opens up for was important to explore. Working together is also a much more prolific part of the classroom setting than we thought. Sitting together, working together in pairs and groups, and the social interactions these

settings entail are essential for a child to feel any belonging in a class. The primary user needs to be seen by the secondary users, and included in regular activities. The secondary users need to be able to share their experiences with the primary user. Building strong relationships with and through the avatar is essential for it to be used, and the primary user to be included as intended. Whether working, playing, or talking, the primary user needs the ability to express him/herself through emotions, personality and movement.

**The shape does not invite bringing the avatar to other settings than just sitting on the classroom desk.**

- 2 None of the experts or users we talked to would bring the AV1 out of the classroom unless for a very specific reason, and strict supervision. When asked why, the dominant answer was a fear of breaking the avatar. Our users did not believe the AV1 could withstand dropping and the rough and tumble of a playground or camping trip.

At Mølladammen they would not even bring it between classrooms, leaving it on one desk, in one classroom.

The white plastic feels cheap and brittle, and does not instill any belief in its ability to withstand any damage from dropping or falling. Users do not want to lift it, since there is no obvious way of holding it safely and areas where you can hold it are sharp or uncomfortable over time.

**Different modus of operation are required for the Avatar to be taken into use.**

- 3 Meeting with Jorun and Alma we learned about the primary user, we got lists of what their needs were in the use of the avatar. Important for us to consider is how the health mode of the user is visible in the avatar so the secondary user can see it. It needs to show if the primary user is participating in a passive mode (this is when they would want to

be present but not interacted with) and on the other side it would need to show if the primary user wants attention so it can be included.

This information was also reflected in interview with Heidi, explaining the importance of reading her students.



nytt nytt  
...laben nedenunder og se:  
fantastiske produkter  
...kling av nye idéer  
...stemte designe  
...«til pall»-baren



**UNIKIA** This friendly face meets you when you go into Oslo's most designerly shop, Unikia.

# 4 TRENDS

IN THIS CHAPTER:

It has been important to the development process to get an understanding of what is happening in the world of robots and social communications. We have summarized parts of our market research and field-mapping.

# TELEROBOTICS

**Telerobotics is the area of robotics concerned with the control of semi-autonomous robots from a distance.** This is primarily achieved through wireless networks (like Wi-Fi, Bluetooth, the Deep Space Network, and similar) or directly tethered connections. Telerobotics contains two major subcategories, teleoperation and telepresence.

Teleoperation is the manned operation of a machine at a distance. Most often, it is used within the field of robotics and mobile robots but it can also be used to describe any form of remote operation of any machinery. It is similar in meaning to the phrase "remote control" but is most often used in research, academic and technical environments.

Telepresence is a more widely used term. Telepresence refers to a much broader range of interactions that include remote viewing of the world. Robots controlled by telepresence are sometimes referred to as telepresence robots, "telecheric" robots or Robot avatars. Often used in combination with mobile devices or computers, telepresence robots allow users to gain a degree of physical appearance in an office, home or classroom setting, even when not being able to be there or participate in person. The robot avatar is the user's physical representation in the physical space. Through the robot avatar, the user can move or look around, all controlled remotely, often from a phone, tablet or computer.

Telerobotics and then specifically telepresence and robot avatars have also given rise to a new branch of telecommuting. Telecommuting is a work arrangement in which employees do not commute or travel (e.g. by bus or car) to a central place of work or education, such as an office or school, but instead participate in the work through digital attendance through computers, tablets or phones. Apart from the AV1 we have explored in this diploma,

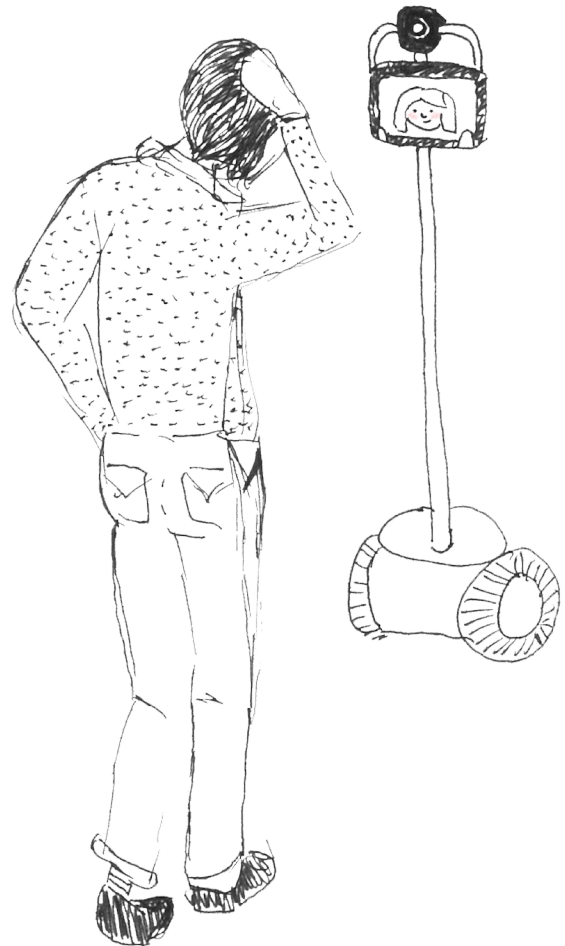

**LEFT** Avatars are not always easy to understand.

**ABOVE** Who said robots don't have any christmas cheer?



## TELEBOTICS



SOURCE: No Isolation

there are many other approaches to robot avatars, or other types of telepresence units in market today. These are primarily divided into two archetypes, desktop telepresence robots, or drivable telepresence robots.

Existing desktop robot avatars primarily exist as a add-on to an existing product like a phone or a tablet. By mounting the smart device in a motorized stand, the user can pan and tilt the view at will, allowing him/her to look around the environment, and interact with the people in it. However the user is limited to the desk he/she is mounted, not able to move from the location.

Drivable robot avatars on the other hand allow for a much broader range of interactions, allowing the user to more or less freely roam around the room, or a larger remote area. Much like the desktop versions, drivable avatars are often a byproduct of an existing product like a phone or tablet, mounted to a movable base unit. Able to operate partly autonomously, allowing them to map and navigate areas by themselves, without direct control or supervision by a user.

There are many examples of existing solutions, both in desktop and roaming robotic avatars. Kubi by Revolve Robotics, Galileo by Motrr, and Swivl are examples of desktop versions, while some examples of roaming robot avatars include Beam by Suitable Technologies, Double by Double Robotics, RP-Vita by iRobot and InTouch Health, Anybots, Vgo, TeleMe by Mantarobot,

and Romo by Romotive.

Most of the existing solutions of telepresence robots are based on a two-way communication, allowing the primary user to see and hear, and be seen and heard in the remote location. This is done through a two way link, broadcasting both video and sound both ways. They are also often focused towards a professional market, focusing largely on productivity and work efficiency.

**This is what perhaps sets the AVI from No Isolation apart from its competitors. A focus not only on the practical functionality of robots, but also on the social aspects makes the AVI something of a loner on the market right now, as we see it.**

Using mapping methods from systems oriented design, we mapped out and placed our project according to what already exists in the market. Analyzing and evaluating other solutions, we aim to find new ways of using materials aiming to give our final proposal better tactility and moving away from the slick industrial plastic look we saw in many other solutions.

Market analyses can be found on the following pages.

# USER CONTEXT

Mapping features a selection of all robots we have looked at throughout the process. We believe these to represent the existing market well. We have chosen not to look at industrial robots due to the extremely different settings and purposes.



\*There are a total of 53 similar products we have found. All have similar shapes, looks and functions so they have been left out for this map.



# EXPRESSIVENESS

All of these robots we have chosen to analyze here come to be in regular contact, and in use by people. Exploring the emotional and intentional expressiveness of the existing products gives us a idea of the typical solutions used when expressing with humans.

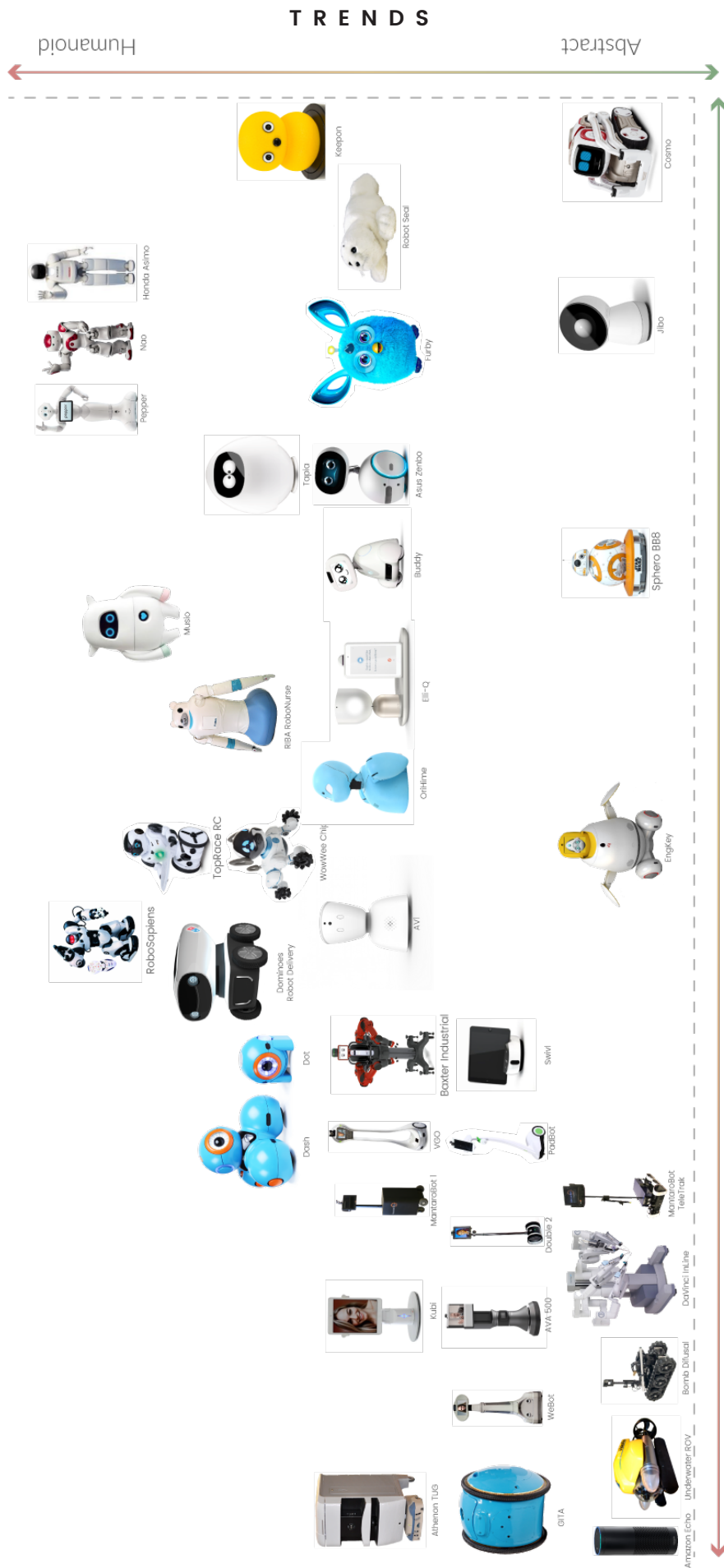

# ESTETICS

We quickly discovered that there is a certain form-language and material choice dominant in the field. Since our solution is an avatar for the child, it is important so show some personality in the design choices. By analyzing the existing materials and colorchoices, we can try to avoid using the same and in so doing avoiding becoming just "another robot".

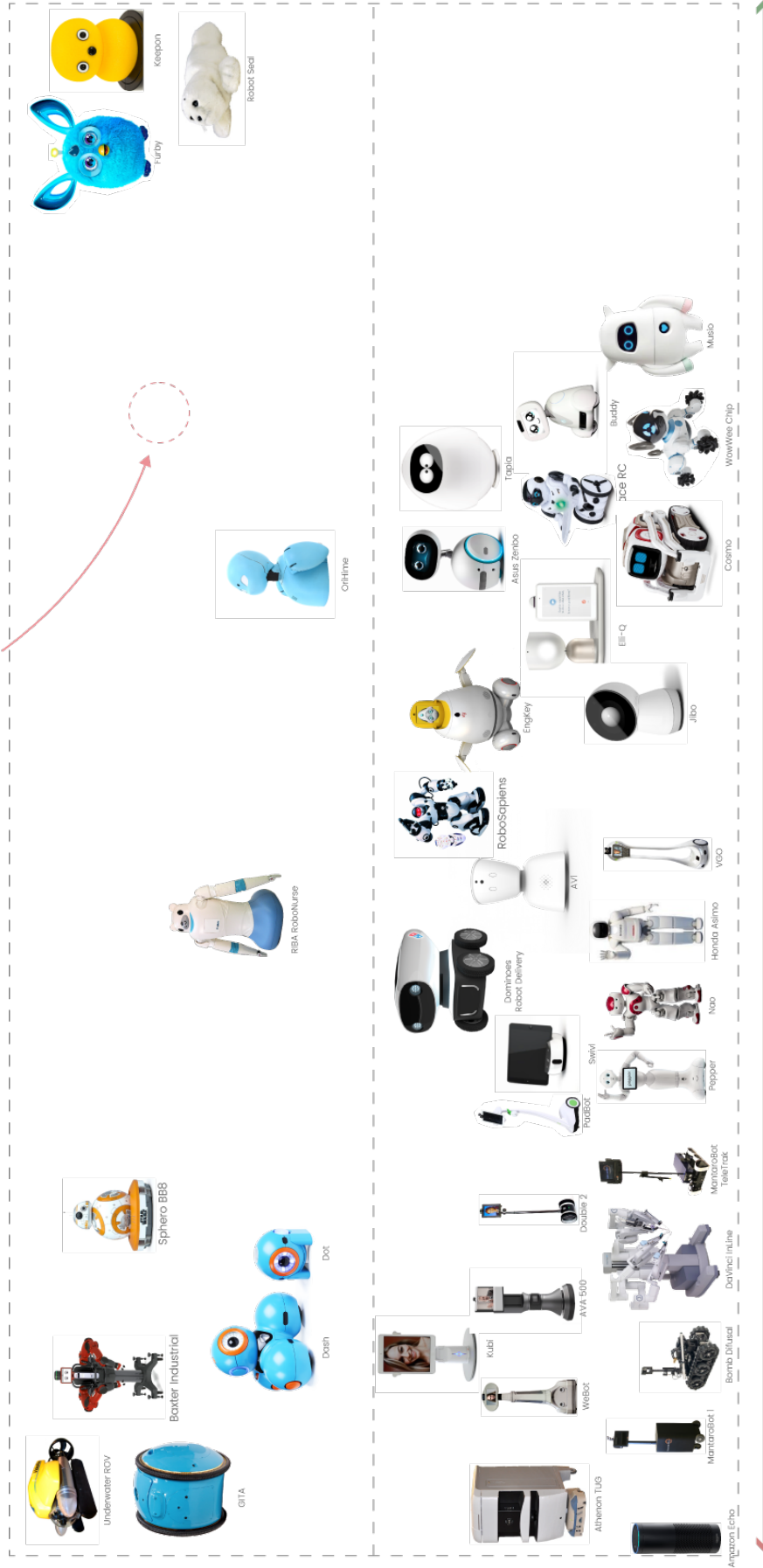

# TRENDS

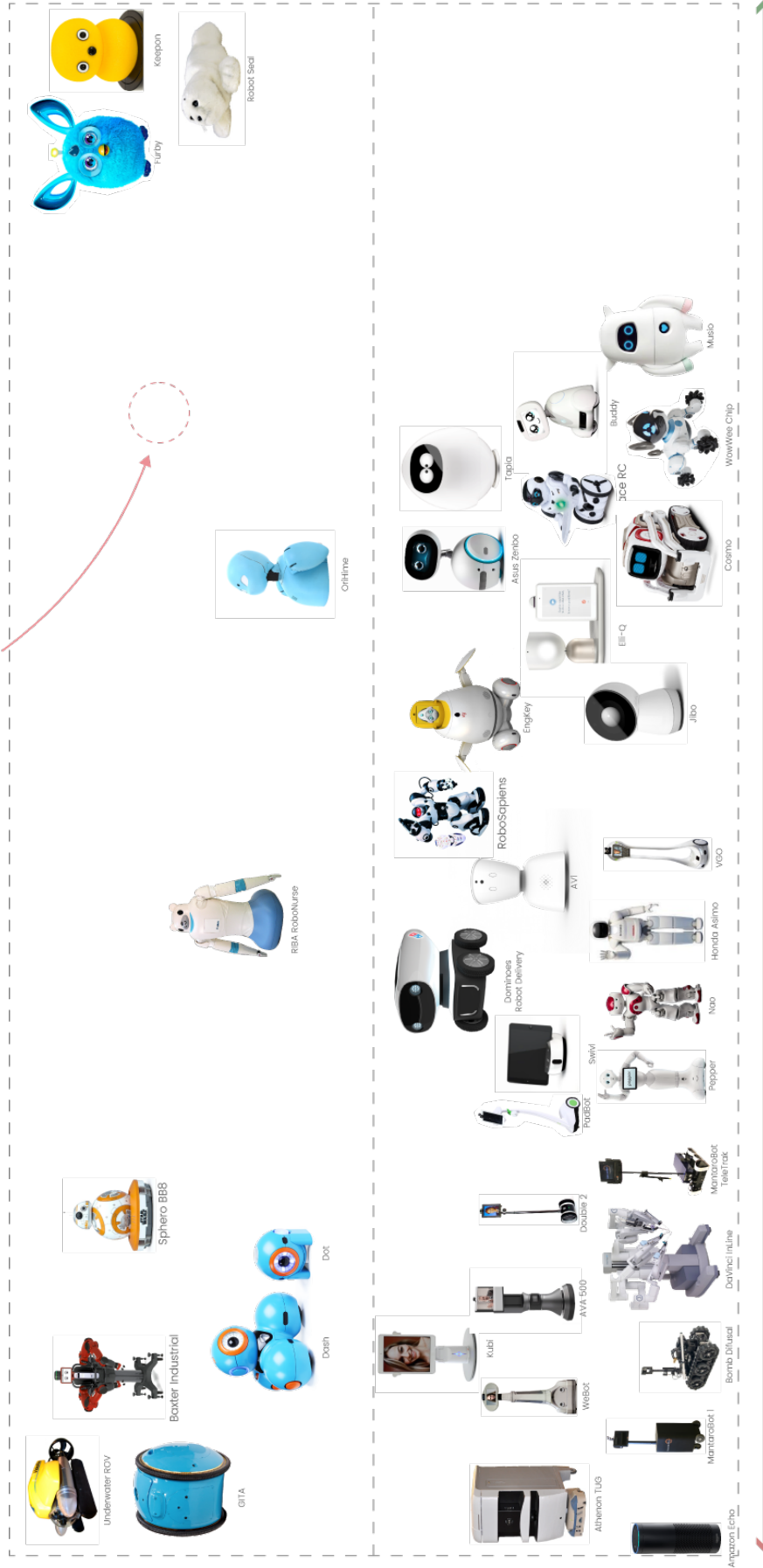

We are working with children and young people. Our final proposal must be able to be handled by our usergroup, and live up to the required needs in both mobility and size.

## MOBILITY & SIZE

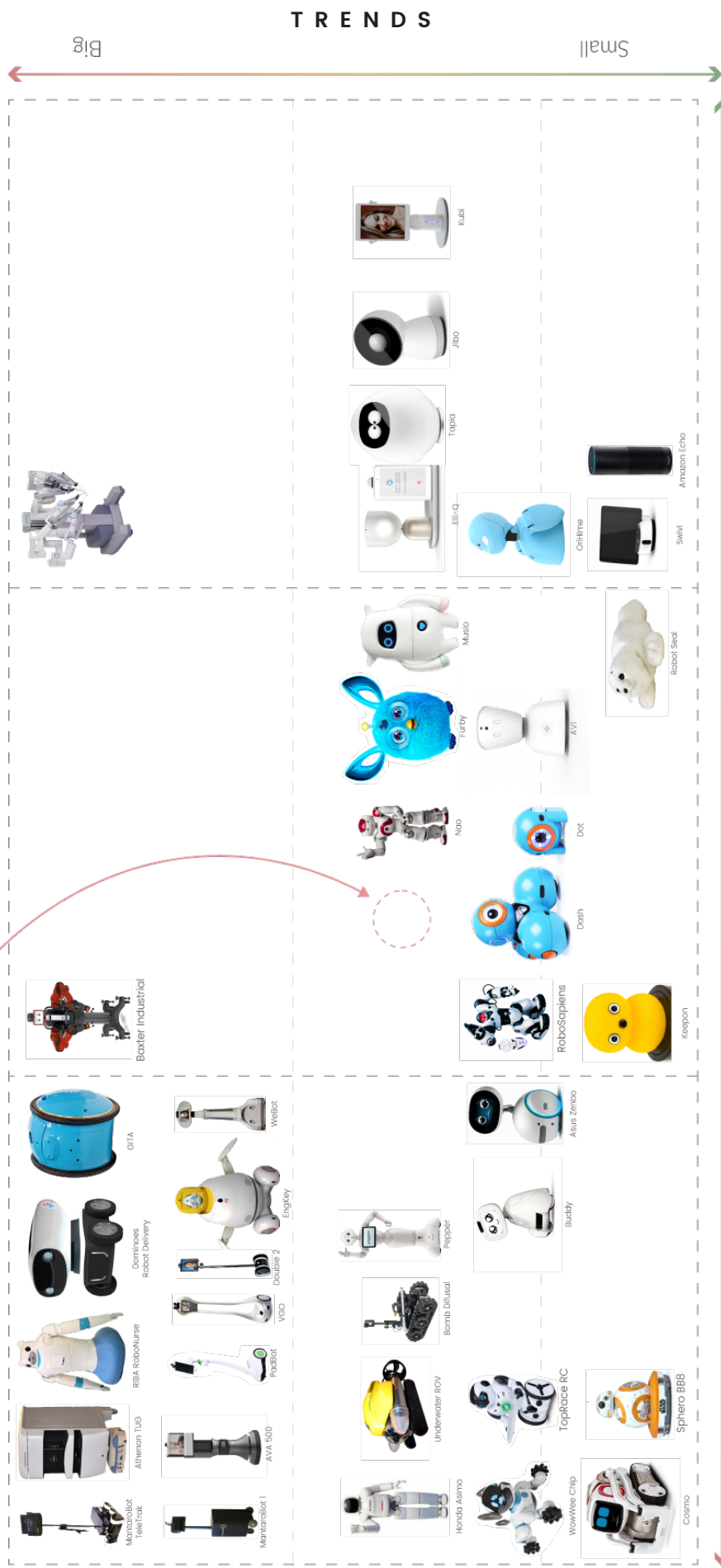

# SOCIAL ROBOTS

## Telepresence

### MantaroBot TeleTrak

**Producer:** Manataro Robotics  
**Price:** Apx. 30.000,- Nok.  
**Size:** 170 cm.  
**Locomotion:** Tanktracks.  
 Remote controlled.  
**Type/Focus:** Industrial/Professional telepresence.  
**Connectivity:** WiFi/4G  
**Concept:**  
 Roaming telepresence robot for a rugged industrial setting. Enabled for simple interaction with physical items through remote arm. Meant to be used in rugged settings. Allows users to drive around a remote location interacting and talking with people and things, even while not being there physically.  
 Two Way communication. Videocalling.



### VGO

**Producer:** Vecna Technologies  
**Price:** Apx. 40.000,- Nok.  
**Size:** 150cm.  
**Locomotion:** Segway.  
 Remote controlled.  
**Type/Focus:** Productivity, Telepresence / Education.  
**Connectivity:** 4G  
**Concept:**  
 Roaming telepresence robot for a social or office setting. Most often encountered in a office or school setting. Allows users to drive around a remote location interacting and talking with people, even while not being there physically.  
 Two Way communication. Videocalling.



### Kubi

**Producer:** Revolve Robotics  
**Price:** 5000,- Nok and upwards.  
**Size:** Apx. 40cm.  
**Locomotion:** Stationary.  
**Type/Focus:** Prouctivity & Telepresence.  
**Connectivity:** Wifi/4G  
**Concept:**  
 Uses existing tablet/app to make a rotating/bending video-caller robot. Allows more flexible engagement with remote locations through videocalling. Enabled through existing video conferencing apps on the tablet/phone.  
 One of many similar solutions.



### AV1

**Producer:** No Isolation.  
**Price:** 25000,- Nok + 12.000,- Nok pr. year.  
**Size:** 28cm.  
**Locomotion:** Stationary.  
 Rotating.  
**Type/Focus:** Social Robot Avatar.  
**Connectivity:** WiFi & 4G.  
**Concept:**  
 The AV1 is a robot avatar meant to take a sick users place in the classroom and social settings. The user controls the avatar remotely, in real time, via the accompanying app installed on a personal smart device, such as a smartphone or a tablet. Through the app the user can turn the robot on, look around through the movement and rotating of the avatar's movements, and communicate with teachers, friends and family on the receiving side.



### OriHime

**Producer:** Ory Lab  
**Price:** 7000,- Nok.  
**Size:** 25cm.  
**Locomotion:** Stationary.  
 Rotating.  
**Type/Focus:** Social Robot Avatar.  
**Connectivity:** WiFi.  
**Concept:**  
 The robot avatar OriHime aims to eliminate social isolation, but it is not a conversation partner, or something that will play with you and keep you company. Instead of creating an artificial interaction, OriHime is a robot designed to facilitate connections between humans.

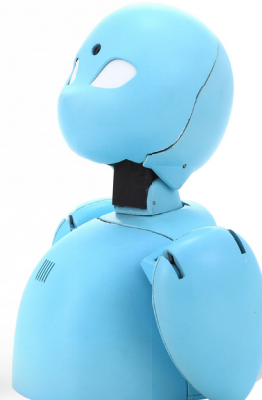

### NAO

**Producer:** SoftBank Robotics  
**Price:** 60000 kr.  
**Size:** 50cm.  
**Locomotion:** Walking.  
**Type/Focus:** Humanoid interactive companion robot  
**Connectivity:** AI.  
**Concept:**  
 NAO is a personalizable and interactive robot. His humanoid shape and body movements give him life and make him a truly endearing companion.

He can walk, talk, feel touch, hear and see what is going on around him, letting him also respond, and take actions based on this input.

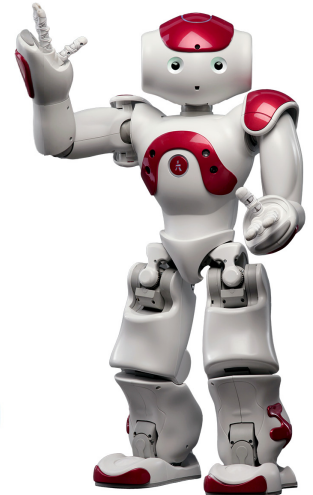

**Pepper**

**Producer:** SoftBank Robotics  
**Price:** 150.000,- Nok.  
**Size:** 120cm.  
**Locomotion:** Self driving. Can drive upwards of 3kmp/h.  
**Type/Focus:** Interesting experiment of natural interaction with robots.  
**Connectivity:** AI.  
**Functions:** Pepper is capable of identifying the principal emotions: joy, sadness, anger or surprise.

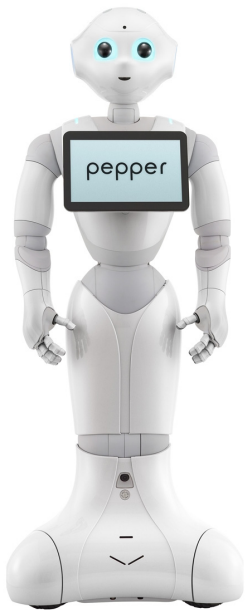

**Elli-Q**

**Producer:** Intuition Robotics  
**Price:** Not yet available  
**Size:** Apx. 30cm.  
**Locomotion:** Stationary.  
**Type/Focus:** Personal Assistant.  
**Connectivity:** AI & WiFi.  
**Concept:** AI controlled robot assistant for the elderly. ElliQ will remind users of events in their diary, or when it's time to take medication, while also suggesting activities like exercises or podcasts to listen to. Video-calling functions, connecting the elderly to their family. Design and shape important for concept. Not "traditional" robot, but more designed to be a beautiful desktop item, like a lamp.



**Jibo**

**Producer:** Jibo  
**Price:** Not yet available  
**Size:** Apx. 30cm.  
**Locomotion:** No. Stationary.  
**Type/Focus:** Personal Assistant.  
**Connectivity:** AI & WiFi.  
**Concept:** AI Controlled personal assistant for helping around the house and with life. Two hi-res cameras recognize and track faces, capture photos, and enable immersive video calling. Artificial Intelligence algorithms learn your preferences to adapt and fit into your life. Hands-free reminders and messages, so you'll never forget and can always be in touch. 360 microphones and natural language processing let you talk to Jibo from anywhere in the room. Like a personal assistant, JIBO proactively helps you, to make everyday tasks simpler and easier. Communicates and expresses using natural social and emotive cues so you understand each other better.



**Buddy**

**Producer:** Bluefrog Robotics  
**Price:** Not yet available  
**Size:** Apx. 50cm.  
**Locomotion:** Self driving/-controlled motion. Can drive around the house.  
**Type/Focus:** Fun companion robot for family life.  
**Connectivity:** AI & WiFi.  
**Concept:** AI Controlled personal assistant for helping around the house and with life.. Reminders of important tasks and events. Home surveillance. Playmate. Voice-operated. Music player. Skype/Calling functions. Telepresence. Smart-connections to the rest of your devices. AI Photo/Video. Medication reminders. Fall-detection (elders). Open Source.

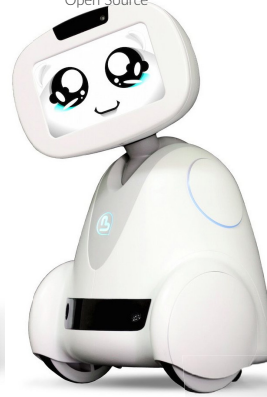

**Amazon Echo**

**Price:** 1700,- Nok.  
**Size:** 25cm.  
**Locomotion:** Stationary. Companion app for smartdevice.  
**Type/Focus:** Home assistant.  
**Connectivity:** AI over WiFi  
**Concept:** Plays all your music from Amazon Music, Spotify, Pandora, iHeartRadio, Tuneln, and more with voice control. Fills the room with immersive, 360° omni-directional audio. Allows hands-free convenience with voice-control. Hears you from across the room with far-field voice recognition, even while music is playing. Answers questions, reads audiobooks and the news, reports traffic and weather, gives info on local businesses, provides sports scores and schedules, and more using the Alexa Voice Service. Controls lights, switches, and thermostats with compatible WeMo, Philips Hue, Samsung SmartThings, Wink, Insteon, Nest, and ecobee smart home devices. Always getting smarter and adding new features, plus thousands of skills like Uber, Domino's, and more





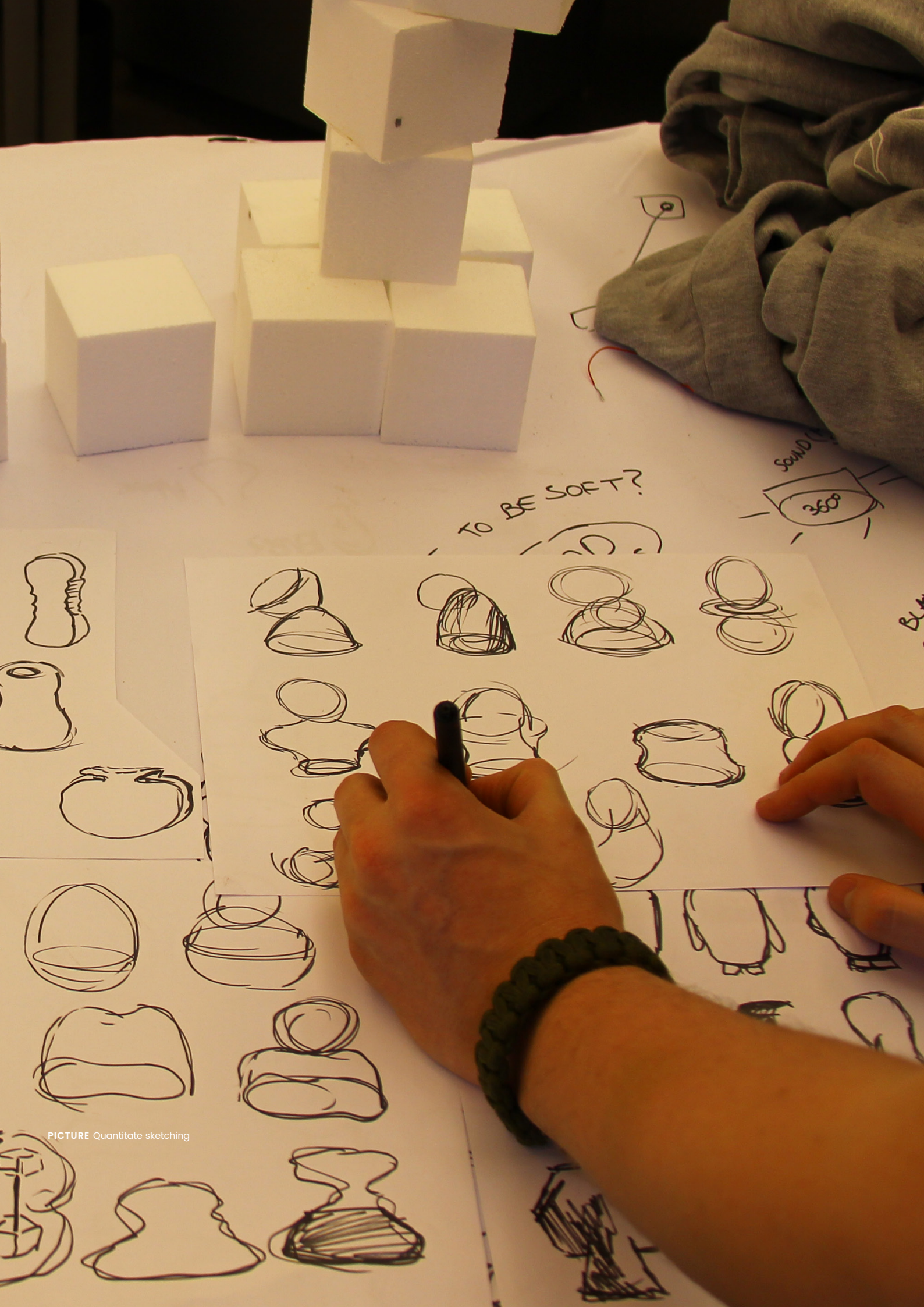

TO BE SOFT?

SOUND

360

BLA

PICTURE Quantitate sketching

# 5

## CONCEPT DEVELOPMENT

IN THIS CHAPTER:

We will go through our development and concept iterations based on our user and context research.

We will explain the methods, steps and evaluations used during the concept phase and what we have taken with us in the final design proposal.

# EARLY EXPLORATIONS

## SHAPE & FUNCTIONS

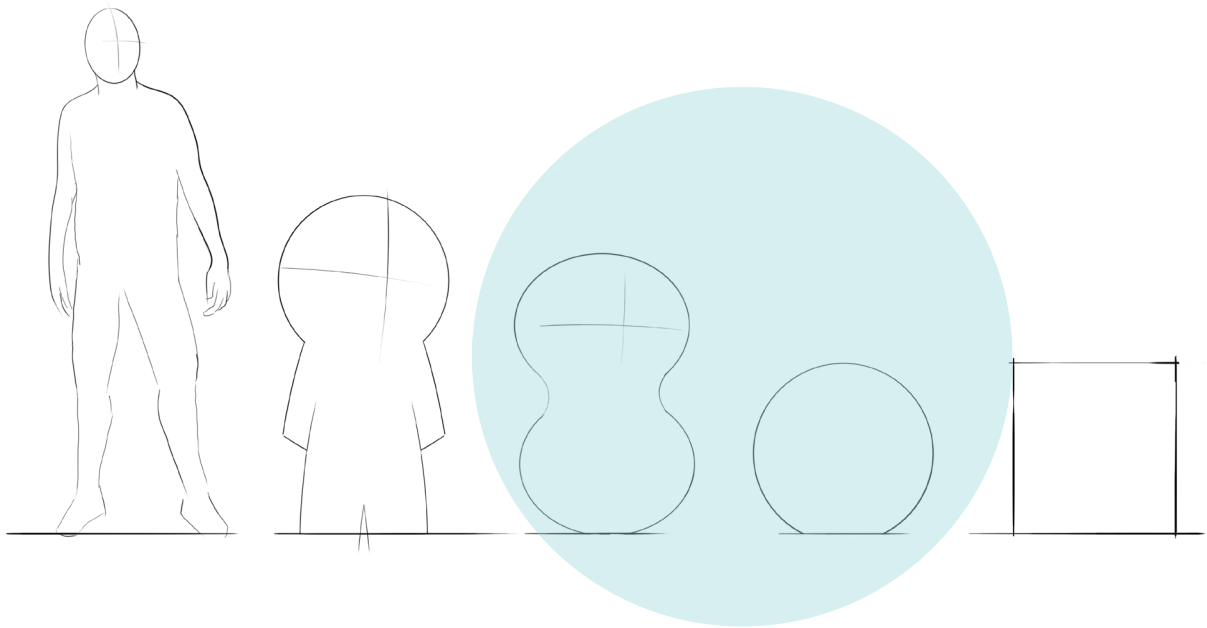

When making an avatar to represent a child or young adult we wanted to balance between making a 1:1 representation of the child and a technical box with all required functions.

We felt a natural starting point for developing a new solution would be to explore shapes, materials and the "look & feel" of a new avatar.

Looking at different levels of abstraction of a human, we discussed how much abstraction is needed for the human side still to be recognizable, but not "uncanny valley".

A fully automatic robot child taking the child's place would be both ethically questionable and extremely expensive and complicated, but a black box while fully functional, would perhaps portray little of the child on the other side.

Through our research and testing we saw that we wanted the avatar to have a "character", so it would not just represent the child, but also be its own being. We hypothesized that giving it a readable shape, with a face and human-like features would make it intuitive for the secondary users to know its purpose. We would have to explore this more, through size, functions, shape and testing, to see what level of abstraction our design would need.



## EARLY EXPLORATION

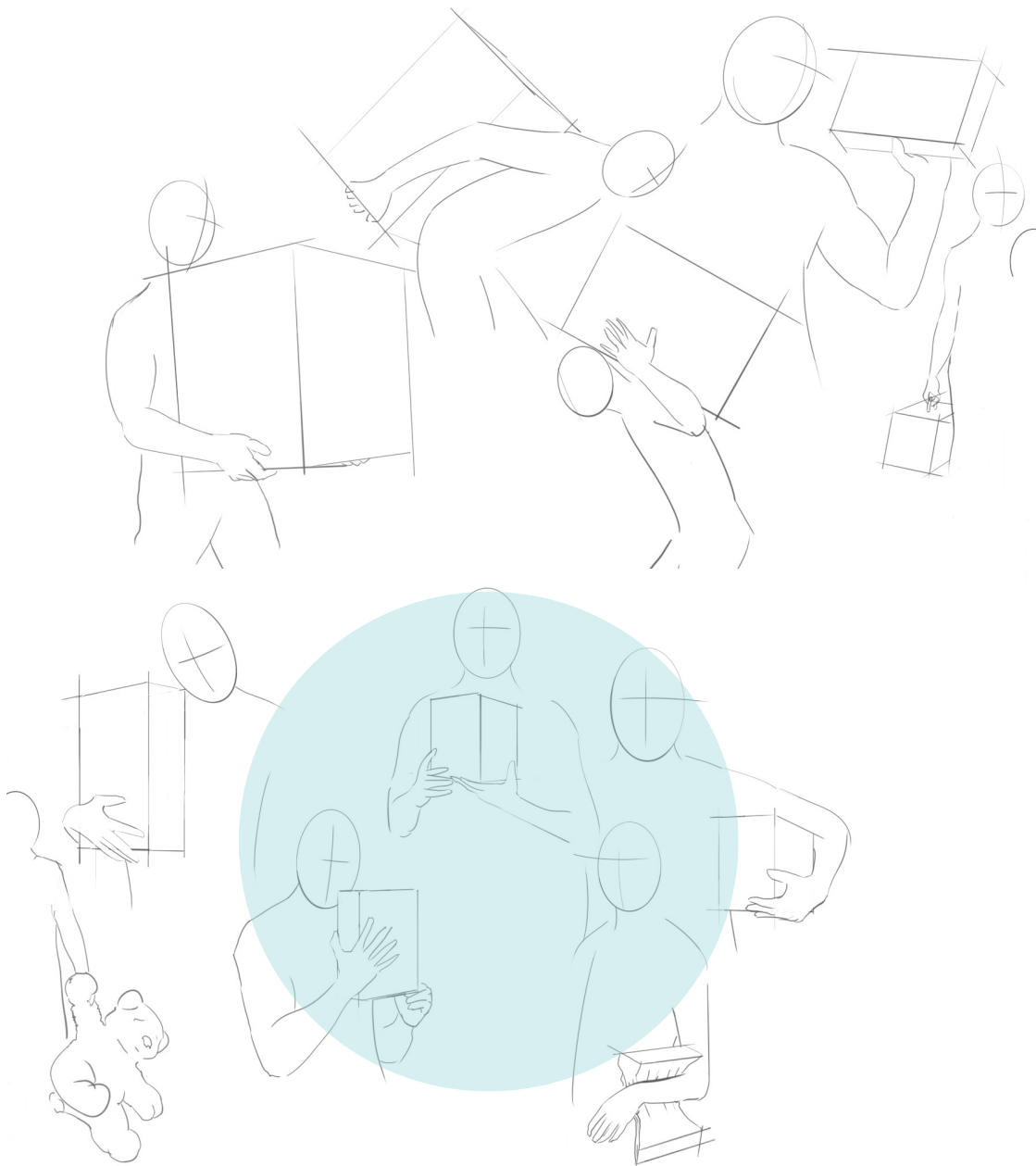

**Through our meetings with Jorun and Alma and the two schools that had been using the AV1 we found that the size of the AV1 was very good in the existing solution. The AV1 is big enough to be noticed in a classroom but also small enough to be put in a child's backpack or carried to where they wanted.**

The number one feedback both we and No Isolation received on the AV1 is the wish for it to be able to drive around by itself, not needing to be carried. At the very start of the project we looked into giving the avatar mobility. In order to be mobile the avatar would need legs, wheels or the ability to fly, but would any of these enable it to keep up with the secondary users?

To be able to join outside, the wheels or legs would have to be of a certain size allowing it to pass terrain and obstacles. The sizes needed would effectively render it impossible to carry for a child, and would therefore be left out of active play. There are examples of this happening in international schools where more conventional telepresence robots have been taken into use to combat social and educational isolation.

Based on these experiences, we want our Avatar to be in the same size range as the AV1, thus remaining carryable, and able to join in on more social activities like play or hanging out on the sofa.

## CONCEPT DEVELOPMENT



Since we had decided that our proposal would be the same size as the AV1, being portable and not a static object that has a specific place, we would have to explore how it could be carried and held.

The concept tells us the avatar is meant to join in on classes on a desk and on the other hand it is intended to join in on play; boat trips, camping trips, cafe visits and hanging out on the couch, to mention some of the many daily activities that may occur.

We had a rapid test with some tape to see how different carrying options allowed us to easily carry the AV1. An important thing to keep in mind while deciding how to carry the avatar is how the primary user sees while being carried along from his screen at home.

1

### HOLDING BY NECK

When first gripping the AV1 we took it by the neck. The shape of the AV1 makes this the most natural way of gripping it, giving support to the hand, while letting the hand get a firm grip around the thinner portion of the neck. In the AV1 this is not a recommended grip, as it can break the gears driving the up/down motion. And even if it did, gripping your friend by the neck is a bit morbid. The view allowed from the avatar's viewpoint is also pointing down, seeing only the ground.

2

### HOLDING BY HEAD

Bigger hands could hold the whole Avatar by its head. But since our primary user group is between 8-13 years old, not all of them have large enough hands. Gripping it by the head also blocks any rotation or possibility for the avatar to look around, effectively limiting the user to just spectating while being carried around.

It is also easy to lose grip of the avatar while carrying like this.



## EARLY EXPLORATION



3

### HANDLE ON TOP

This is a nice way of carrying the avatar. You can relax your arm and you only need one hand. Looking out from the avatar's viewpoint, you are on a very different level than the person carrying you and will look at other people's legs. Having a handle on the top will also easily lead to some "swinging" of the avatar, making the view through the avatar a shaky business. We decided not to use this as a primary way of carrying.

4

### GRIP ON THE SIDE

Giving the Avatar grips on the side will be a two-handed way of carrying it. It's not heavy since you use both hands, and since you lift it quite high, the primary user will have a view quite similar to that of the person carrying it. We will explore this grip further.

5

### HANDLE ON BACK OF HEAD

This one is about the same feel as the handle on top of the Avatar, but the view is even worse. We will move away from this too.

6

### HANDLE ON THE BACK

Putting a handle on the back will clearly indicate what's the front, and the person carrying it will hold it facing the right way for the primary user. However, holding it up like this feels tense on the wrist and taking the weight of the avatar into consideration (1.2 kg) it is heavy holding the whole avatar like this with one hand. Maybe even impossible over time for a child. From this we wanted to take into consideration how to make the user hold it the right way forward.

## CONCEPT DEVELOPMENT

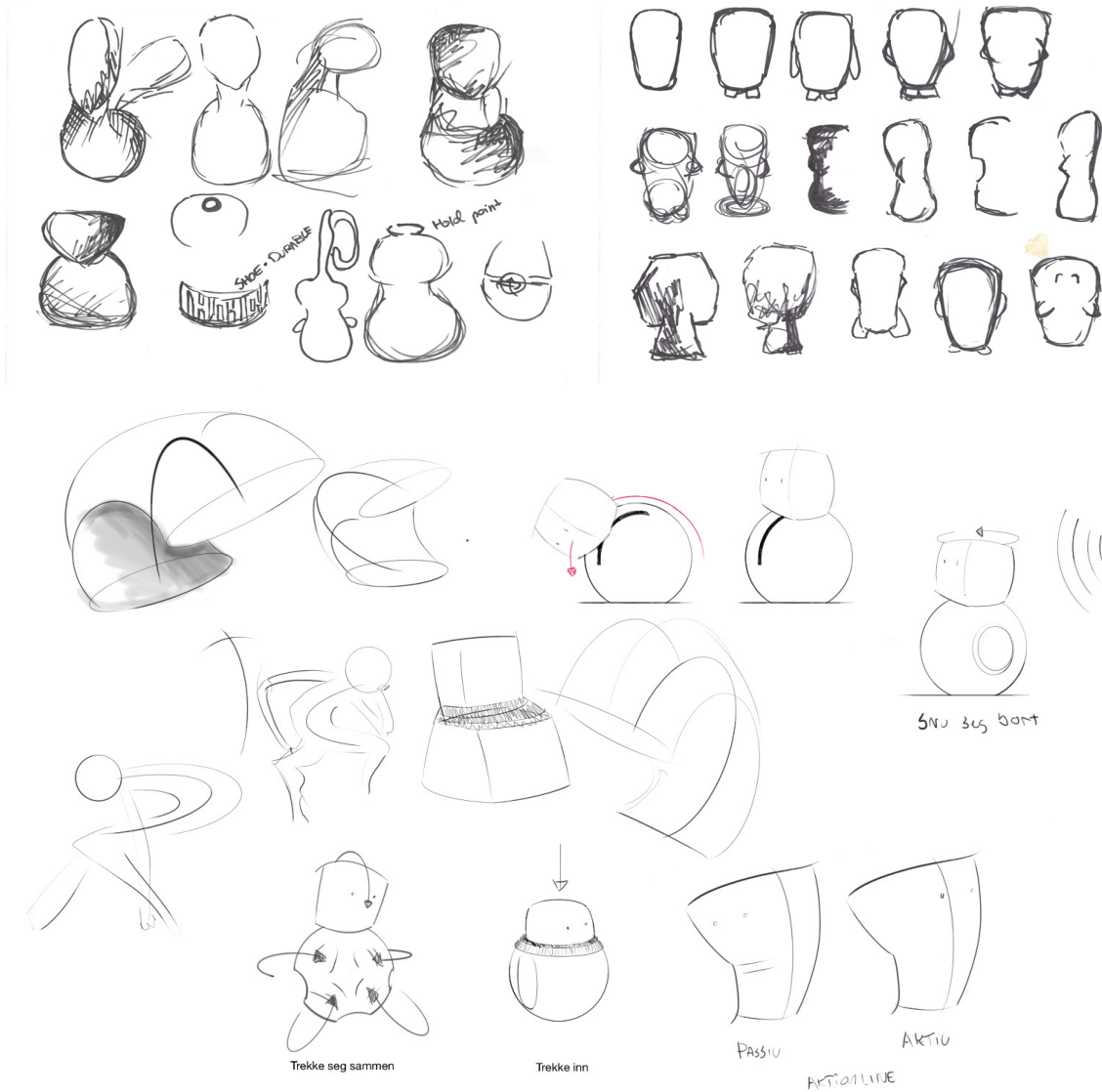

Throughout our entire process, we have been sketching out a lot of ideas for both the shape and functions. On these next pages, we have collected a couple of the major ideas and progress sketches from the early phases of the project, where we wanted to explore different ways we could solve a potential redesign of the AV1.

Early on in the process, we explored how much of a difference we needed to implement in our solution to make it a radically different solution to the AV1, or

what we would have to tweak in the existing solution to solve some or all of the challenges we had found during our insight research.

Some of the earliest sketches portray a continuation of the torso-shape of the AV1.

For much of the early shape exploration, we kept this shape in some of our concepts. The AV1 has a lot going right for it, and the shape we felt was one of them.

One of our readings of the AV1's torso shape, is that it is not a complete figure.

## EARLY EXPLORATION

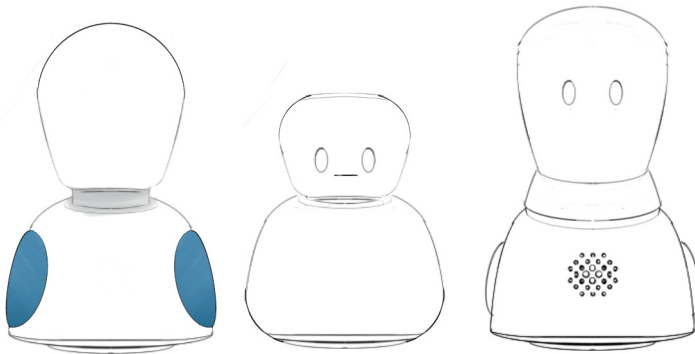
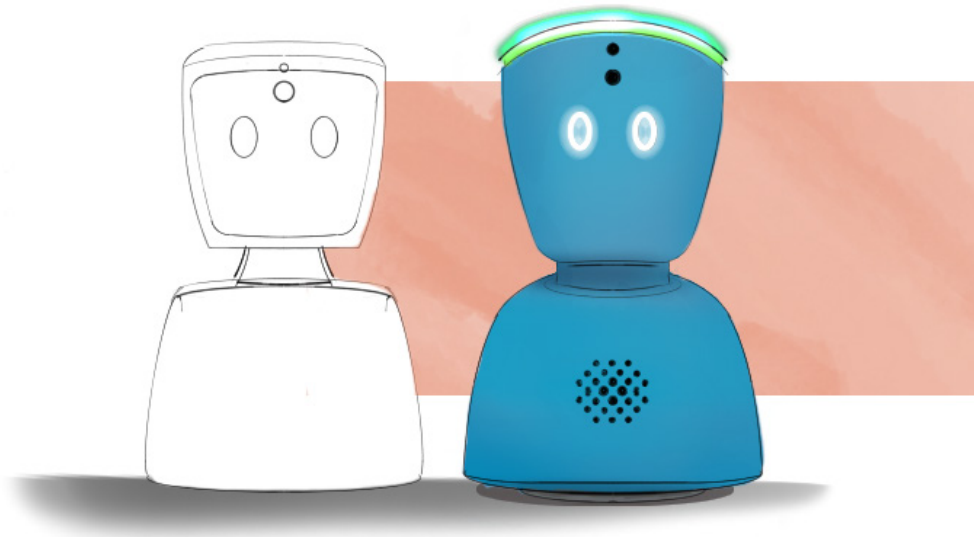

**TOP LEFT** Early shape sketches. Quantitative sketching.

**BOTTOM LEFT** Early shape/function sketches.

**ABOVE** Giving the AV1 some color.

**BELLOW** Warping the shape of the AV1. Incremental change.

The AV1 has an abrupt stop just below where you might read as the shoulders of a human.

We spent a good deal of time trying to tweak the shape of the AV1 to read as a complete figure. By applying different colors and playing with the expressions we could get from a similar shape to the existing avatar, we established that we would have to do more drastic changes to both solve the issues found in the original, and distinguish our solution from the AV1 enough.

From our expert and user research we had a positive view on the fact that the AV1 is its own little "character", in that it has a bit of personality of its own, and is not just an avatar of the child itself. We wanted to explore this more.

## CONCEPT DEVELOPMENT

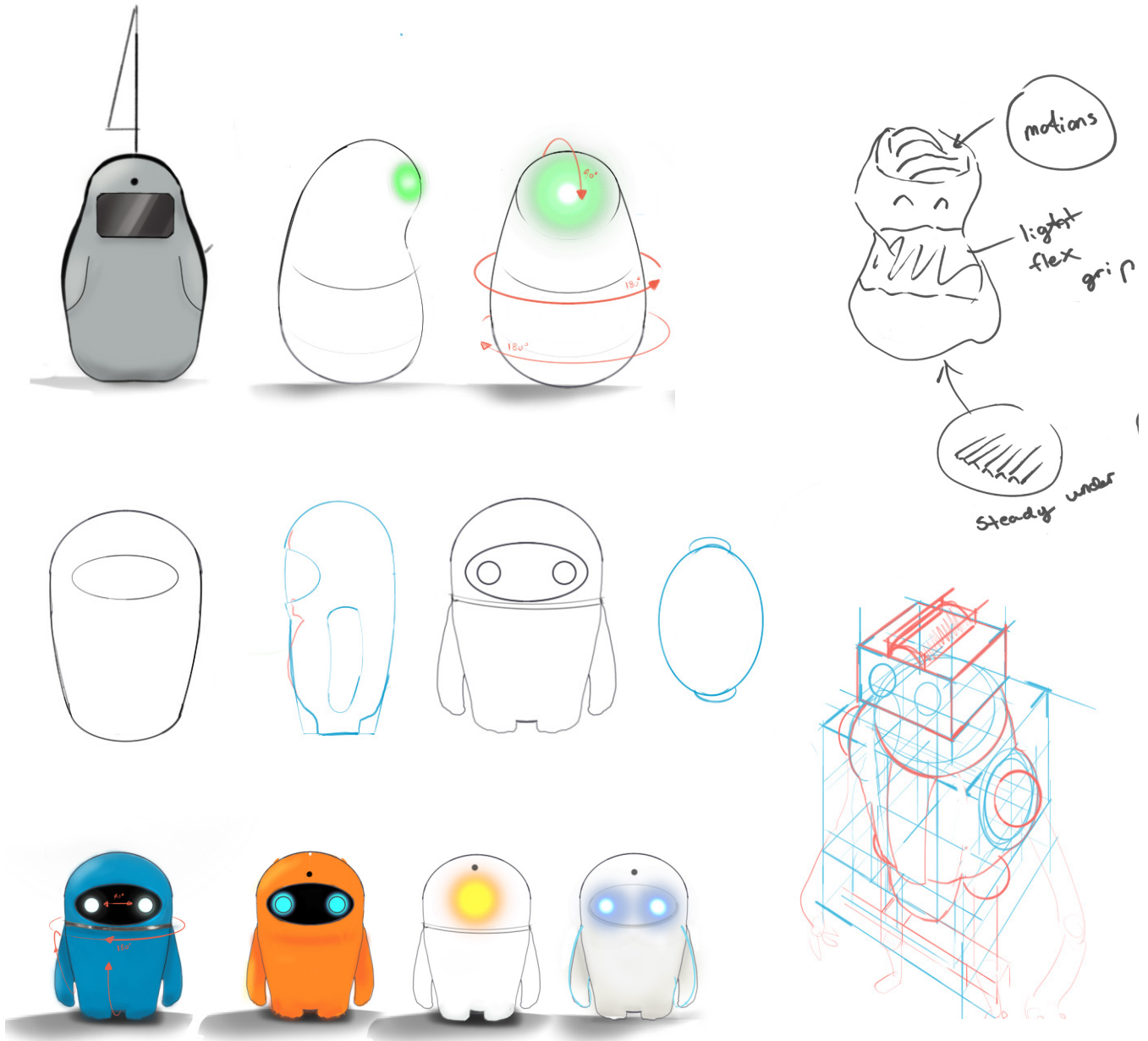

To utilize much of our early insights and exploration, we generated 5 concepts for possible directions we could take further and work within to generate new ideas.

- Torso Character
- Whole Figure Character
- Pieces
- Non Figurative
- Radical Change

### Torso Character:

Since the AV1 is a torso shape, we wanted to challenge ourselves with what we could do with the same base shape. Just using a head, neck and a "shoulder" section, a torso is the bare necessity to generate a "human" shape.

### Whole Figure Character:

Giving our avatar more features, we wanted to explore how it would be perceived if it was closer to a real person, with arms and legs.



## CONCEPTUALIZING EXPLORATION

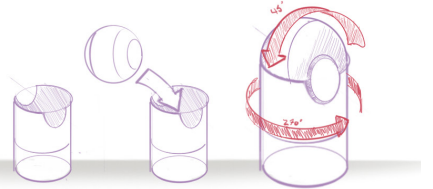
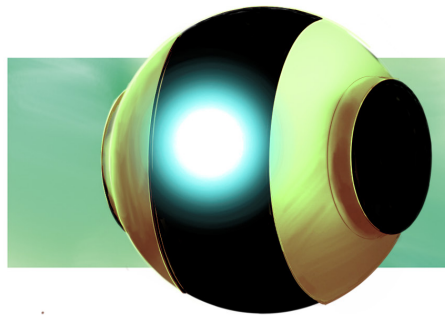
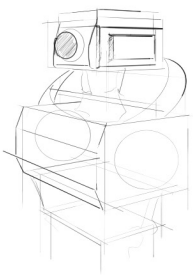
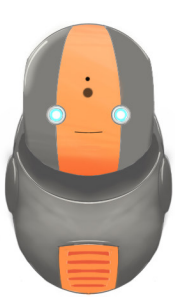
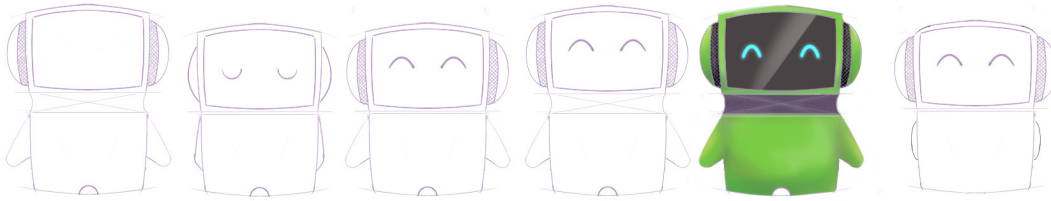

### Pieces:

Maybe the avatar could be modular, allowing users to bring a small piece, and install it in different bodies, based on the needs of the situation.

### Non Figurative:

Does the avatar even need to look like anything recognizable, or could it be a shapeless blob, or a square. From our user insight phase, we had seen that most people were very positive towards the AV1 being a small "human", making it easier for them connect to it. We wanted to see if we could replicate this, even with a completely different shape and expression. Exploring this gave us valuable insight into why a more recognizable shape is a strong selling point for the AV1, and is ultimately why we decided against this concept.

### Radical Change:

Thinking it would be interesting to explore more radical changes, we wanted to see if the avatar even had to be a robot at all. Maybe it could just be an app, or a flying drone that could fly by itself and go anywhere. In the end we decided to keep the concepts more grounded, discarding this concept.

Using these 5 general concepts, and some of the sketches done during the early project process, we refined our concepts further, finalizing them in some rough 1:1 physical models.

**TOP LEFT** Exploring non figural shapes.

**TOP MIDDLE** Early functions in place

**TOP** Refining a character. Exploring the use of a screen in the avatar

**LOWER LEFT** Giving a complete shape to the avatar

**BOTTOM** Pieces and radical concepts.

**MID** Sketching out how a pieces concept could work.



## CONCEPT DEVELOPMENT

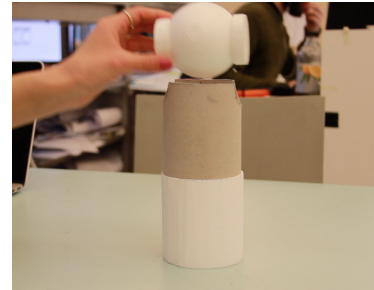
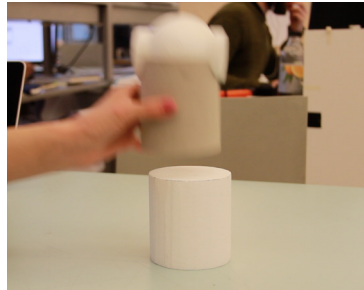

**3D modeling of first ideas, get it up in 1:1 gives us a chance to better see what we think on paper and then we can easier talk around it and see what we want to test further. Since we are two working together do we also see the benefit of illustrating it through rapid physical prototyping.**

Looking at dimensions, seeing and feeling it physically and testing the functions;

What if it was split in different pieces, dividing different functions in the pieces, you could then choose what to bring to the situation. Is this beneficial? How do we ensure that you don't lose any parts? Should it have a main docking station? We don't want to step over any privacy boundaries and raise undue concern; and by having smaller pieces will it be considered more of a "spy-tool"?

Looking at an Monolithic shape, not humanoid. All of the functions you need is to be able to see, hear and speak. These do not need a specific "packaging", but maybe the user needs one to feel connected to it? Intuitive? This is maybe for a more elderly user.

Full figure, legs, body, movable arms and a face, a character that can do more than the AV1, but will these things enable it to function better in given situations? Will you notice the arm motion in the classroom? Is it better than indicating with light as the AV1 is doing now? Creating a character makes you see personality

and you get a connection to the Avatar in a different way than in the monolithic for example. This is insight we gained from the quick testing.

The Eyes on the AV1 are static and cannot change, how can we use eyes to create different expressions? Happy/satisfied, neutral? We have to consider what is necessary to express? Will you need an expression for angry, or would this be something you wouldn't change? How are these expressions changed? In the app with symbols? Voice controlled? Facial recognition?

The AV1 is a torso, is this the bare minimum you would need to see it as a representation of a human? What is needed? How would it be to cover the hole shape in textile and give it more possibilities for moving around?

From doing these early prototypes we found a direction we wanted to explore further. We wanted a human connection in the visual aspect of the avatar, we wanted it to have eyes to express emotions and we wanted more human movements. We needed to see how our ideas would function with the tech we were going to use, so rapid tests using Arduino was up next.



## EARLY EXPLORATION

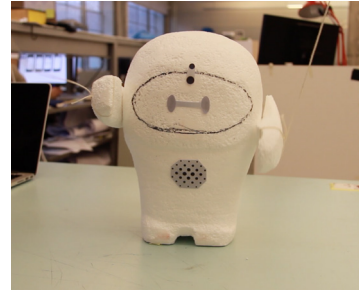
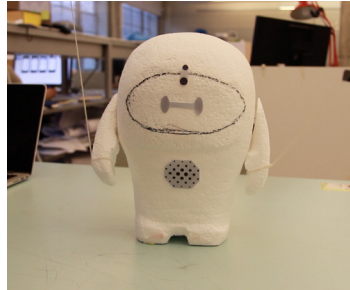
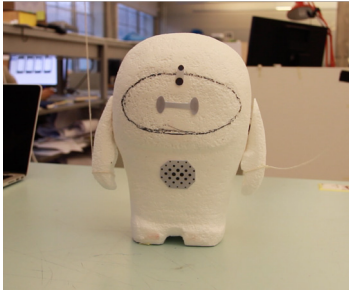

**Giving our avatar arms was something we discussed a lot and tried implementing. Based on our classroom observations, we know how much raising your hand means, and how often you do it.**

What we discovered, however, by prototyping this is that the arms need to be so big to even be noticeable, we'd have to scale the entire avatar up so much it would lose all meaning. We would need to decide on another way of getting attention.

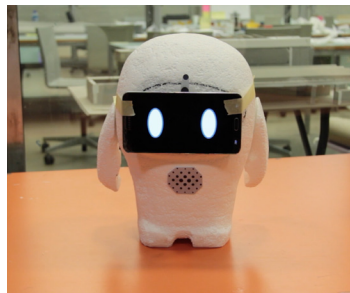
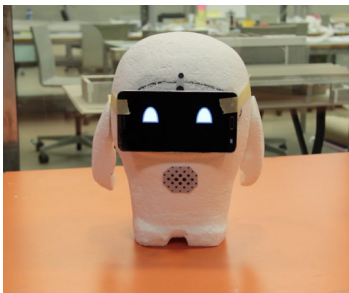

**The AVI has a set of eyes giving it a distinct face. One of the drawbacks of the current face is that it is static, molded into the plastic. Based on user feedback, we wanted to give the avatar more ability to express.**

We experimented using gifs and short movies giving the avatar's eyes that moved, blinked, and changed mood. We settled on the avatar needing a positive and a negative reaction and a neutral set of eyes.

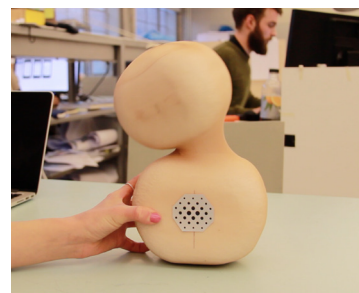
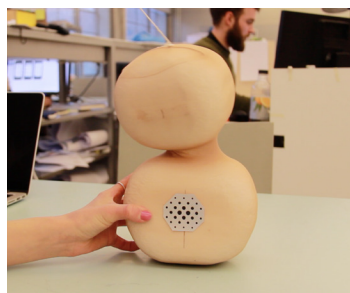
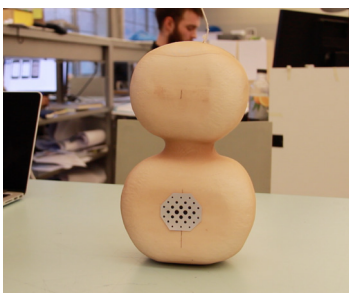

**A flexible neck was something we found interesting. The AVI has one axis of mobility in the neck, a 40 degree vertical rotation. This can be perceived as very static and unnatural. We wanted to explore giving the avatar a more natural motion.**

We had also found the shell of the AV1 to have large holes into the electronics. Using fabric, we explored how we could cover these holes, while still maintaining a flexible joint. This also had the positive effect of giving the avatar a softer, more inviting look.

# VIDEO SKETCHING

**Many of the 1:1 prototypes were also used in several video sketches we made to quickly explore and explain several function concepts. Video sketching helped us visualize our ideas in a low tech, but easily understandable format. These could then be shown to users and our supervisors to further discuss and develop the concepts.**

Since many of the functions of the avatar are dependant on movement or changes over time making these simple videos was the easiest way to prototype them without having to build advanced functional models.

A lot of the experimentation we did was with different kinds of lights, exploring both how to draw attention, but also avoid it.

On the following page, we selected a few examples from our prototyping stage showing many different areas of experimentation.

Based on the results from our sketched prototypes and these video sketches, we decided on the final functions we wanted in our solution.

# VIDEO SKETCHING

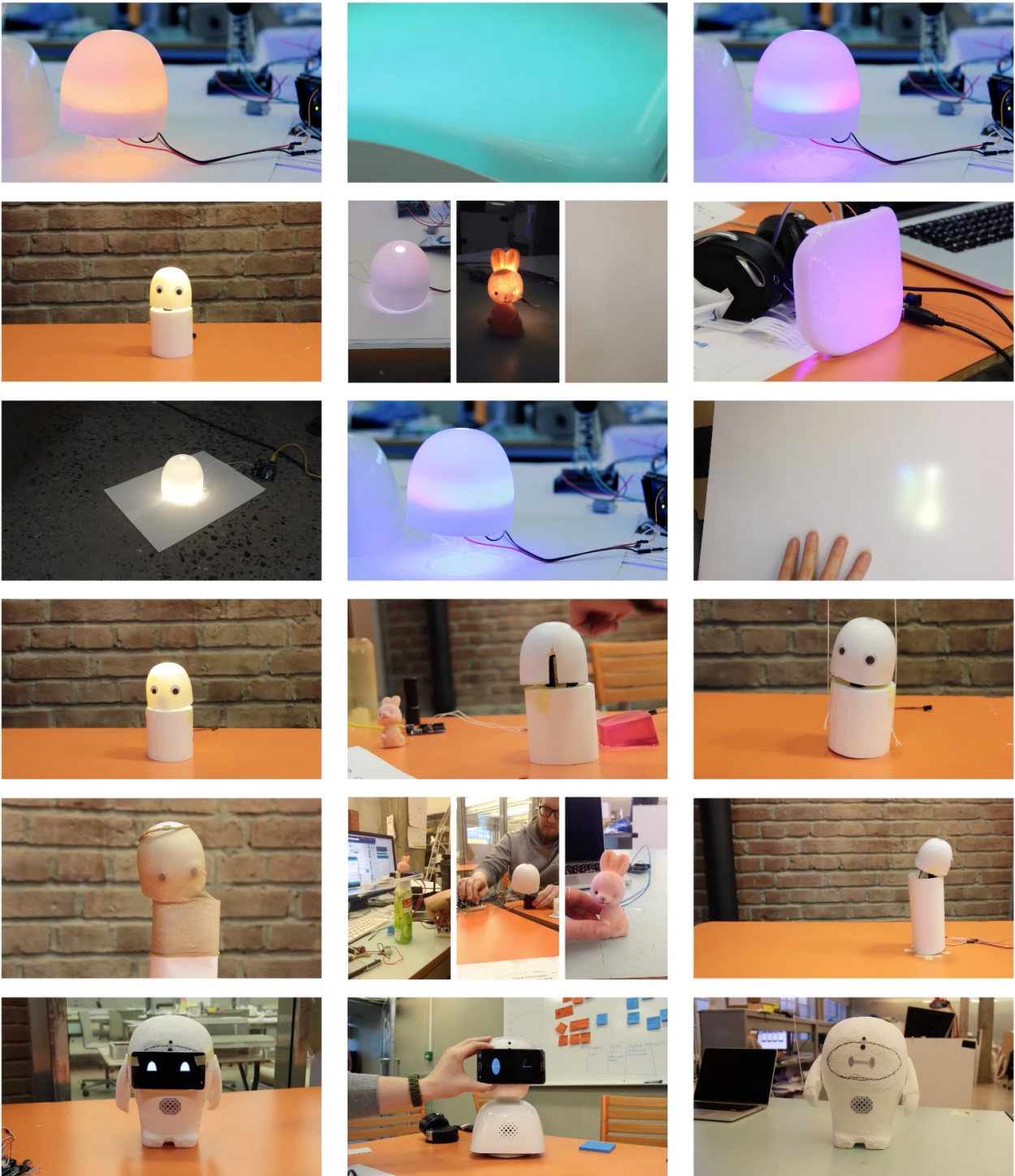



# DEFINED FUNCTIONS

Balancing the physical aspect and the interaction part as been a clear guideline for us during the entire project. It is important that the functions are as clearly defined as the shape.

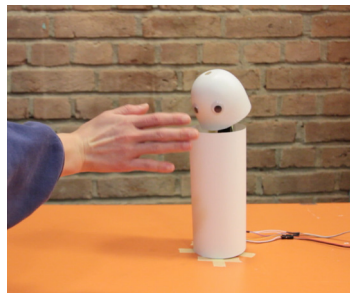
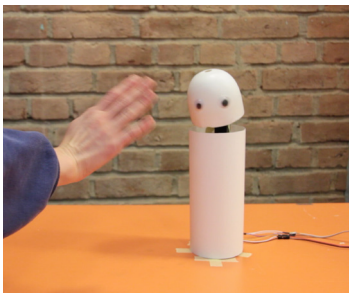

**The AVI moves its head up and down, to turn the hole body will turn, we wanted a more human motion, could you turn the head as we humans do instead of the hole body?**

We made a new movement for the neck, allowing for 40 degree turn of the head, and kept the motion of up and down. We also kept the 360 turn of the body, but this will follow after the neck motion if the user wants to look all around.



**We do not want the users to be able to peek into the technology inside the Avatar. In the AVI you can look inside at the joint where neck meets body and on the underside. By covering it with a flexible material we can hide these parts without sacrificing range of motion.**

We did rapid test with covering up with flexible textile or silicone, we see this as a "skin" it moves more humanlike and cover the joint as we aimed on. This can be in textile or also use silicon for instance. Covering the joints and openings also helps prevent dust and dirt getting into the finer electronics.

## DEFINED FUNCTIONS

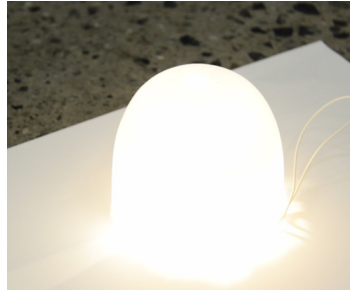
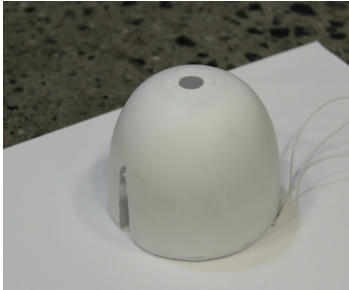

**The Avatar will need to get the teachers attention in a room filled with children. How can this be done? Raising your hand is the normal gesture as a physical student, so what can we use?**

Testing with arms moving on the Avatar did not catch as much attention as we hoped for and they would need to be infeasibly large, so we decided to try with different lights instead. Lights of different intensity levels and rhythms catch the eye in a good way, as we discovered through testing. This is already done in the AV1, but too discrete.



**The primary users of the avatar suffer from many different illnesses and need the option to participate in a passive mode and be able to get the educational input but not actively participate.**

Using light as we do with getting attention you can play with colored light to clearly show a difference from the other modes, and you can have it pulsing so it is not forgotten and just a subtle indicator for the secondary users interacting with the Avatar.

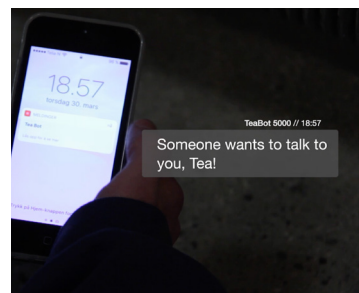
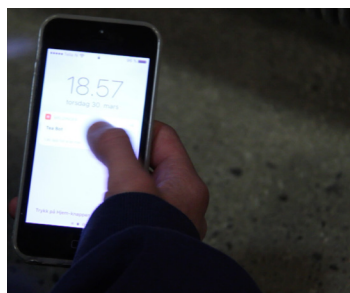

**Giving the secondary users a way of contacting the primary user through a discreet "nudge" function. How can this be implemented, but not too intrusive, neither in the robot or for the sick child?**

We want to give the avatar a function that allows the secondary user to give the primary user a notification in the app, telling the person that someone wants to talk to him or her. This can be an encouragement to join in, and a subtle way to show that you are thinking of the person or just a nudge to say hi.



# EXPRESSIONS

**The face of the AVI is very static. It has two round eyes that light up in white when the avatar is on, and turns off when it powers down. We wanted to give the user the ability to express emotions and reactions through our design, a want reflected in much of our user research.**

What emotions do humans have, and what are the corresponding facial expressions belonging to these emotions? Which of these would our robot need to get through a regular school-day? Using what psychologists refer to as the basic emotions we analyzed what primary emotions to express.







In 1992, Paul Ekman identified six basic emotions (anger, disgust, fear, joy, sadness, and surprise) Ekman puts forth that basic emotions evolved in response to the ecological challenges faced by our remote ancestors and are so primitive as to be 'hard wired', with each basic emotion corresponding to a distinct and dedicated neurological circuit. Being hard wired, basic emotions (or 'affect programs') are innate and universal, automatic, and fast, and trigger behavior with a high survival value. (Ekman. (1992)

Even though we would like to include all emotions in our avatar, we see that is neither practical (how would you effectively change between a large scale of expressions) nor necessary.

Out of these 6 basic emotions, only two are needed in a classroom setting for a viable function. Joy and a negative reaction, here represented through a combination of anger and disgust. Like with our shape we needed to abstract a human face. Taking a cue from classic animation and Disney, we looked into how they in the 50s had perfected abstracting the human expressions.

**In the book *The Illusion of Life: Disney Animation*, two pioneers of animation, Ollie Johnston and Frank Thomas go into great detailing about how abstractions of the human face can be done.**

Since the avatar is controlled through an app on the user's phone or tablet, and the avatar itself will have certain limitations on movement and flexibility, certain abstractions can be made immediately. An easily readable body language can be a challenge to understand, both because of the size (visibility), and the mobility. Facial movement could be limited, and because of the size of the avatar they could be hard to see. From *The Illusion of Life* we learned that the most important part of any emotion is the eyes, and how they are shaped and change with different expressions. Using these simple facts and the knowledge of Disney, the bare minimum we would need for our avatar to have understandable emotions are emotive eyes.

ANGER	DISGUST	FEAR	JOY	SADNESS	SURPRISE
					
<ul style="list-style-type: none"> <li>• Eyebrows &amp; lips pulled up</li> <li>• Thightening of lips</li> </ul>	<ul style="list-style-type: none"> <li>• Eyebrows &amp; upper lip pulled up</li> <li>• Wrinkled Nose</li> </ul>	<ul style="list-style-type: none"> <li>• Eyebrows pulled up &amp; together.</li> <li>• Stretched mouth</li> </ul>	<ul style="list-style-type: none"> <li>• Cheeks raised</li> <li>• Muscles around eyes tightened</li> <li>• Lip corners raised</li> </ul>	<ul style="list-style-type: none"> <li>• Inner corner of eyebrow raised.</li> <li>• Eyelids loose.</li> <li>• Lip corners pulled down.</li> </ul>	<ul style="list-style-type: none"> <li>• Entire eyebrow raised</li> <li>• Mouth hangs open.</li> <li>• Eyelids pulled up.</li> </ul>

## EXPRESSIONS

**One of the most distinct features of the AV1 are its oval eyes. They can be seen whether the robot is on or off, and are a prominent part of what makes the avatar recognizable.**

We wanted to keep the primary oval shape of the eyes. Having a pair of recognizable eyes will indicate a family of products, even though the rest of the avatar is completely different.

Out of the 6 primary emotions, two emotions are needed (Joy and Anger/Disgust) in our robot, along with a neutral state. Further emotions could be added later, through software updates, directly being updated in both the app, and portrayed on the MicroLED screens running the eye animations.



### The oval neutral eyes

Keeping in line with the existing AV1, a pair of neutral eyes are the default state for the responsive eyes. These will blink every so often, as to prevent coming static and dead, as demonstrated in the Illusion of Life (Johnston, O., & Thomas, F. (1995))



### Joyful eyes

A happy reaction is one of the most natural emotions we can express. Giving this response to the avatar allows the user to react positively if something nice happens, he is interested or generally likes what is going on. These responses last just a short time, returning to the default state, oval eyes, after a while.



### Negative response

A negative response can be used both as an expression of resignation, for example if you get a piece of homework you don't like, or as a direct negative, showing you do not like what is going on or are disgusted.

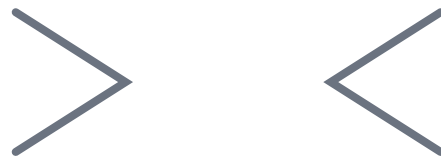

## CONCEPT DEVELOPMENT

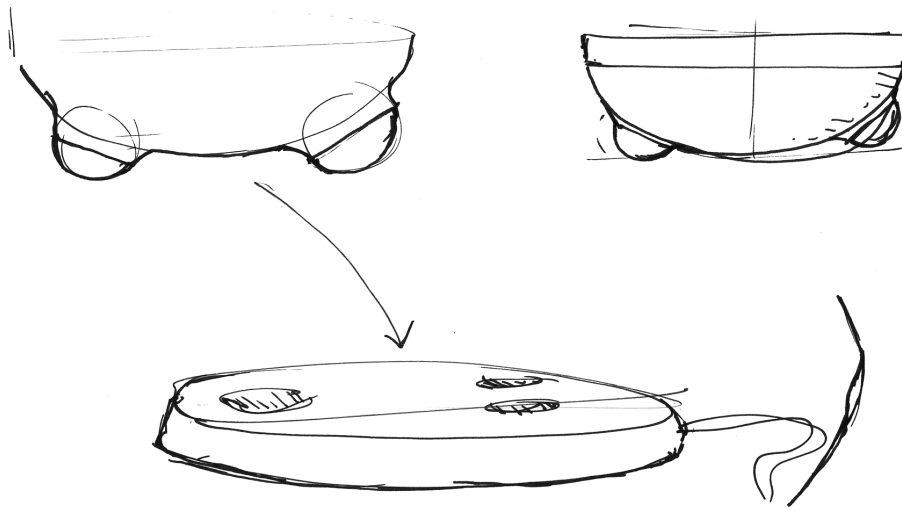

We want a steady base for different surfaces the Avatar will stand on, we want to test with a tripod style, giving it 3 rubber "feet" to give good stability.

Giving the Avatar the possibility to charge without any plugging in we make a docking station for the three legs to be placed in for charging as a daily routine.

Sketching on the shape and creating an "arm" for gripping the Avatar, is something we wanted to test in our prototype with children, we would go for a round arm for the first testing seeing the effect this gave to holding and carrying it.

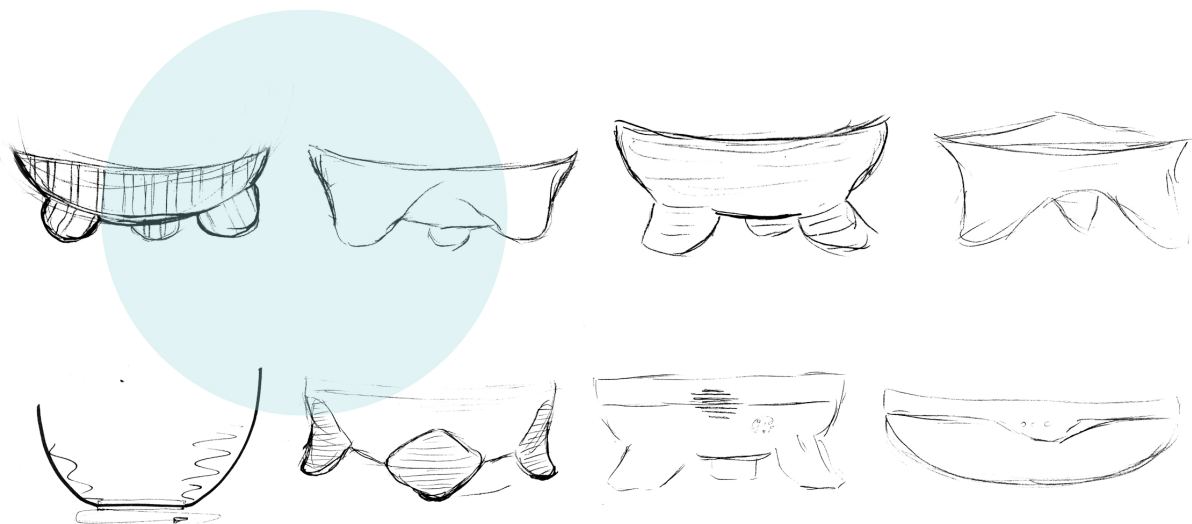

CONCEPT DEVELOPMENT



# DEFINING THE CONCEPT

From all our sketches and prototypes, we synthesized a list of demands that would define our concept. Using a combination of the functional demands, and ideas from the sketch generation, we developed a shape that could fulfill all the demands set before it.

Giving the avatar a soft outer shell would make it more tactile, while closing the body off but still keeping the flexibility intact, allowing for movement. A prevalent feedback we heard both from users and experts was

an expressed wish for the avatar to be customized to fit the individual. An exchangeable fabric body allows for a wide range of expressions, both in color and fabric type. The fabric body can also help absorb shocks or bumps in case of dropping or falling.

A whole figure, with a discernible base-element will give the avatar a fuller look, completing the figure.

A tripod style mount will give stability while lifting the avatar off the ground, underlining the completeness of the form.



Situation

Sound Record:	✓	Sound Recieve:	✓
Volume control:	✗	Video Recieve:	✗
Video Record:	✓	Movement control:	✗
On/Off:	✓		
Level of Activity:	✗		
Movement of Avatar:	✓		
Avatar Info:	✓		



Sick Child

Sound Record:	✓	Sound Recieve:	✓
Volume control:	✓	Video Recieve:	✓
Video Record:	✗	Movement control:	✓
On/Off:	✓		
Level of Activity:	✓		
Movement of Avatar:	✗		
Avatar Info:	✓		

SHAPE	MATERIAL	EXPRESSION
Desktop (100-300mm) Easy to carry Grip & Weight Indoor - Outdoor Steady Robust Avatar - Person	Clean Practical Outdoor use Water proof Tactile Tough	Passive Active I want to speak / Attention please. Positive Reaction Negative Reaction
<b>Technical</b> Battery docking		

Avatar Info

SPEC	Must	Should	Could
Mode:		✓	
Battery:	✓		
User Info:			✓
4G Connectivity:	✓		
Wi-Fi Connectivity:	✓		

Technical Specs AVATAR

SPEC	Must	Should	Could
Internal HD Camera:	✓		
Speaker:	✓		
Microphone:	✓		
4G Connectivity:	✓		
Wi-Fi Connectivity:	✓		
Camera Movement:	✓		
Signaling func.:	✓		
Moving parts:		✓	
Visibility of APP user:			✓
Wheels/Tracks			✓
Flight:			✓



## DEFINING THE CONCEPT

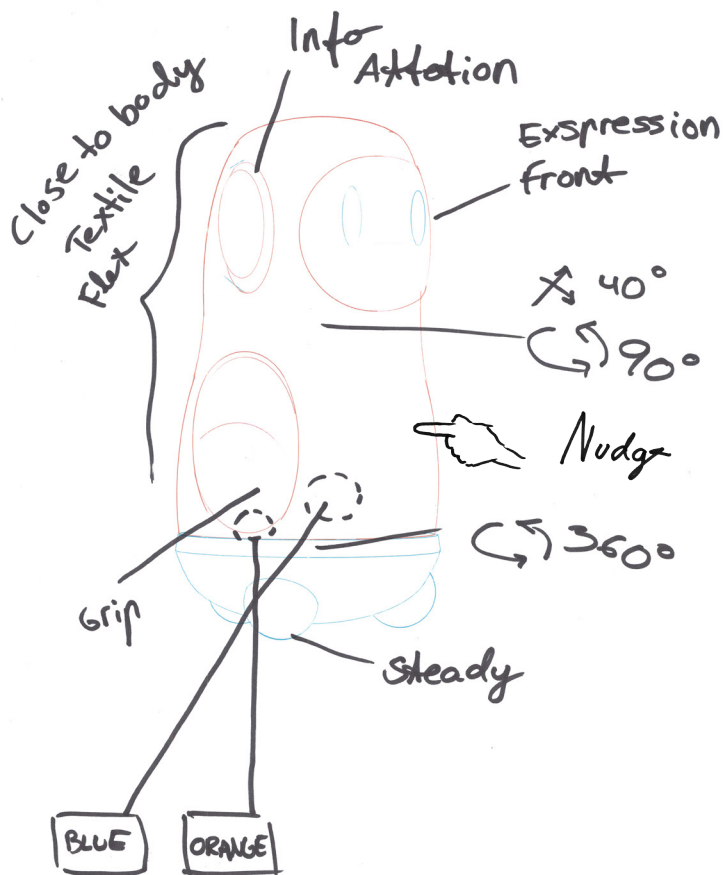
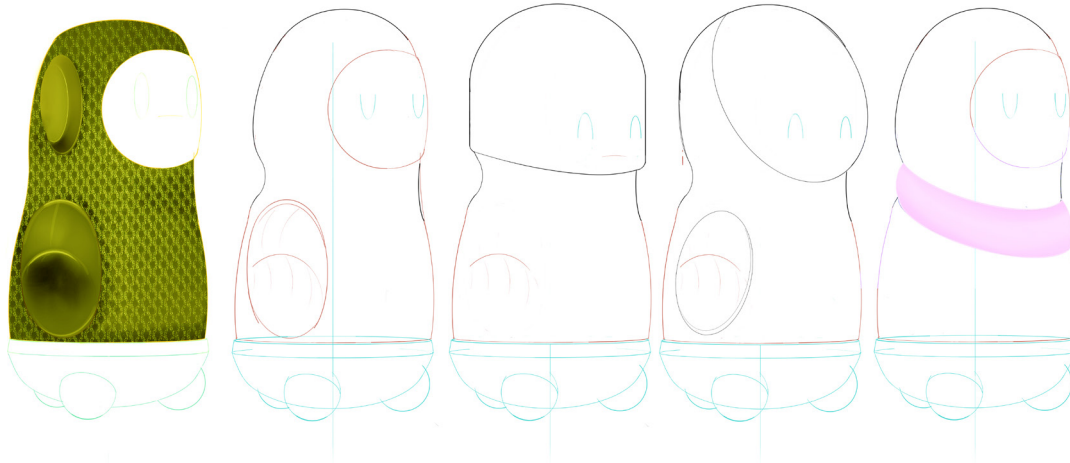

Soft arm-like protrusions from the sides of the main body will act like grips, while also giving a sense of character to the avatar. This will help the secondary users lift, and carry the avatar, not having to fear losing grip of it. These can also act like bumpers in case of the avatar falling over, alleviating fears of it breaking.

A soft round face with light-up eyes bring expression and life to the avatar, being able to be changed by the user controlling it to reflect his/her mood and reactions to things happening around the avatar. We believe this will help secondary users relate more to the avatar, ultimately building better relationships to it and the sick child.

One of the major new functions we wanted to bring to our solution was a new axis of rotation in the neck. From our prototypes we found this movement to give a much more natural feel to the movement of the avatar, giving a greater illusion of life. Because of the soft fabric outer shell we are able to maintain a closed outer surface, even when turning the head sideways. To mimic a human movement, the neck is limited to a 90 degree turn, 45 in each direction. If the user continues to turn the avatar, a 360 degree rotation in the base takes over, allowing for a full turn letting the user see in all directions.

Light up ears are used to relay info about modus and attention, lighting up or flashing different signals, much like the top of the head of the AV1.

CONCEPT DEVELOPMENT

# PROTOTYPING:

TECHNICAL & EXPERIMENTAL

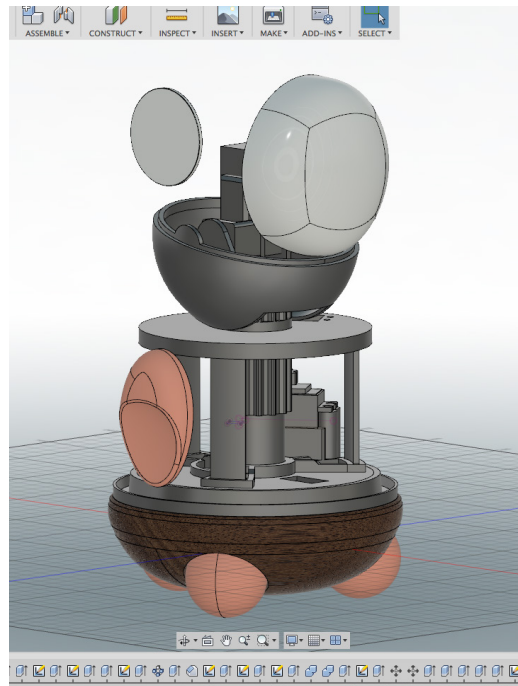

## PROTOTYPING

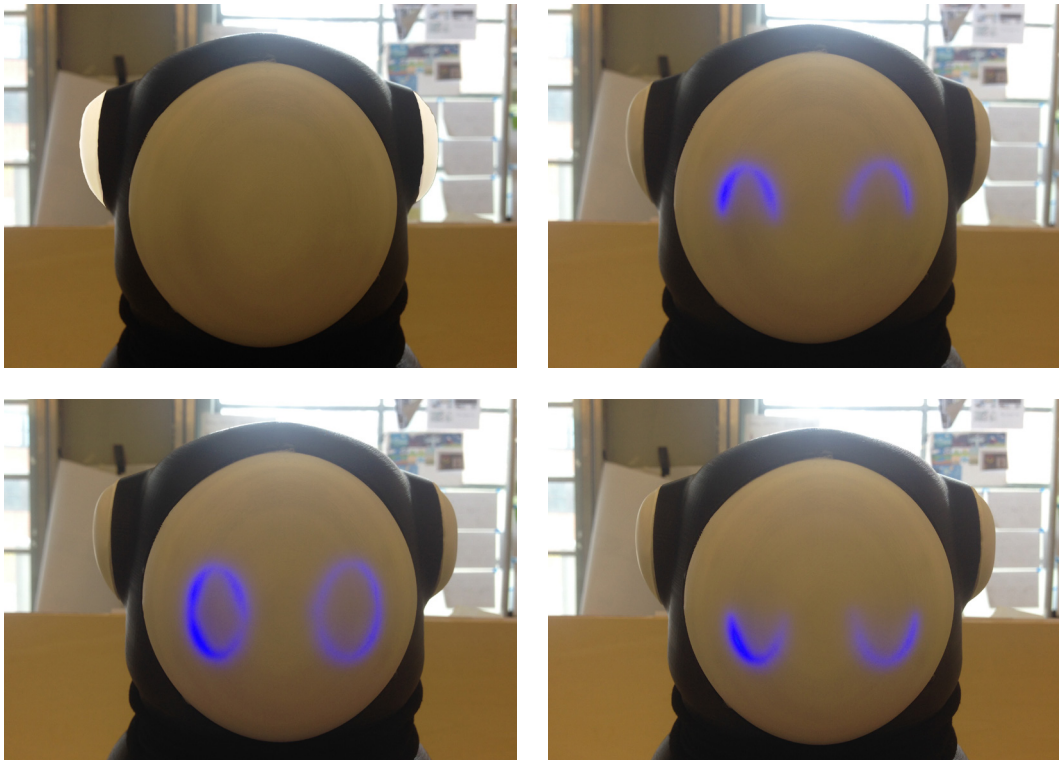

**Since our concept relies on a multitude of functions operating neatly together, the only real way of testing it out was by building several functional prototypes, each one increasingly more advanced than the others.**

Based on the size prototypes we had made during our earlier prototyping stages, we had a pretty clear idea about the size we would want to make the prototype.

Using a set of hand drawn blueprints, a cad model was quickly drawn up in Fusion 360 from Autodesk. This model could later be iterated upon, making multiple versions of all parts, allowing us to prototype digitally how everything would go together and work.

Using AHO's great possibilities for 3D printing, we were rapidly able to prototype several versions both in outer dimensions and with different versions of internal and external functions.

Using basic electronics and Arduino to mock up simple versions of the functions and movement we could quickly iterate on what would, and would not work in a final model.

The prototypes went through several iterations to meet the demands set by the list of demands. Especially the neck portion has been important to solve in a way that will solve the issues faced in the AV1, while still retaining, and even increasing mobility.

Since the prototype would be handled by children and youth, everything was constructed to be durable, with no direct drives, but reinforced gears and shafts.

Special light conductive filament was used to make certain the eyes would perform as intended, even in bright environments.



## CONCEPT DEVELOPMENT



# USER TESTING THE CONCEPT

**To validate and test our design, we conducted a user test session with three users in the primary age group, Birk, Ylva and Tea Oleana.**

They really liked the character, but wondered why it had a helmet? We suspect this opinion might have come from the fact that the neck of the prototype was a distinct white, while the rest of the prototype is black. They did however really like the additional movement in the neck of the prototype, especially when compared to the AV1 (we also let them try out, and play with the existing solution.)

Having eyes that can emote certain feelings and reactions was very well received, but they thought having some type of facial recognition of the user,

letting the avatar portray his/her reactions in real time would be much better than having to send "emojis" from the controlling app like we have planned.

We found that they had a hard time holding the avatar. We had given it small round arms, but these were too small to grip in any reasonable way, but too big just to be hand "rests" for a better grip. We would need to improve this greatly for it to be carryable. The round shape however was great for holding with your arm around it, cradling it in your elbow. Also holding it with both arms was very good.

If it would break during transportation was a concern, and if the different axis of movement could be locked with some sort of transport-lock was suggested as a solution.

# CHECKING IN WITH NO ISOLATION

**While meeting our users, we also set up a meeting with No Isolation to let them know what we had been doing, and show them our concept and prototype.**

In the meeting, the developers and the main entrepreneurs of No Isolation sat down with us to hear and discuss our ideas, and show us what they are developing on their next avatar.

Getting feedback from No Isolation was a great motivation for us to continue developing our concept, but also getting some recognition of our ideas was very fun.

They especially liked having a possibility for the secondary users to "nudge" the primary user in a kind way, and wanted to bring this into their new solution. They were also very impressed with our focus on making the avatar softer and more tactile, shifting away from a hard plastic exterior.

Alongside our diploma project, No Isolation has been developing their own redesign of the AV1, the AV2.

When we discussed their new solution, we were very pleased to discover that many of the insights we had gained during our process were reflected in the findings from theirs. We have deliberately not kept up on their progress, as to not be influenced too much, and keep our own development unbiased by theirs.

More movement in the neck to create a more natural motion, and interactive microLED eyes that could reflect emotions and reactions from the user were some of the things that both our processes had resulted in.

They had also refined the shape and material, resulting in a softer exterior for better handling and holding much like ours.

Even though we were impressed with their development, we did not feel they had taken a drastic enough step away from the existing solution, only tweaking it a little. Since we are much more free to develop our solution in a more radical way, we have completely changed the shape.



"Have you been spying at what we are developing? Because it is funny how similar it is to ours!"



# FURTHER PROTOTYPING:

## REFINING THE PROTOTYPE

**One of the main feedbacks we had from our user-testing was that the avatar was hard to carry. We had given our prototype two small arm-like cylinders on the sides to help with carrying, but this clearly needed to be developed further.**

It has been important to us throughout the entire project to solve how a grip would be. One of the primary reasons the AV1 is not used as intended today we found in our research, is that it is unergonomic and hard to carry due to its shape, leading to it just being left, or users figuring out unintended ways of carrying it, like gripping it by its neck.

Using some low-fi prototyping, we started looking into how we could improve the grip on the avatar when holding it with both hands. From small arm like grips on the sides, the grips were evolved into larger surfaces, giving good grip no matter how you hold the avatar. By using shapeable materials like styrofoam and plasticine clay, we were quickly able to develop multiple iterations, allowing us to quickly test our ideas and discard the ones that did not work.

# PROTOTYPING

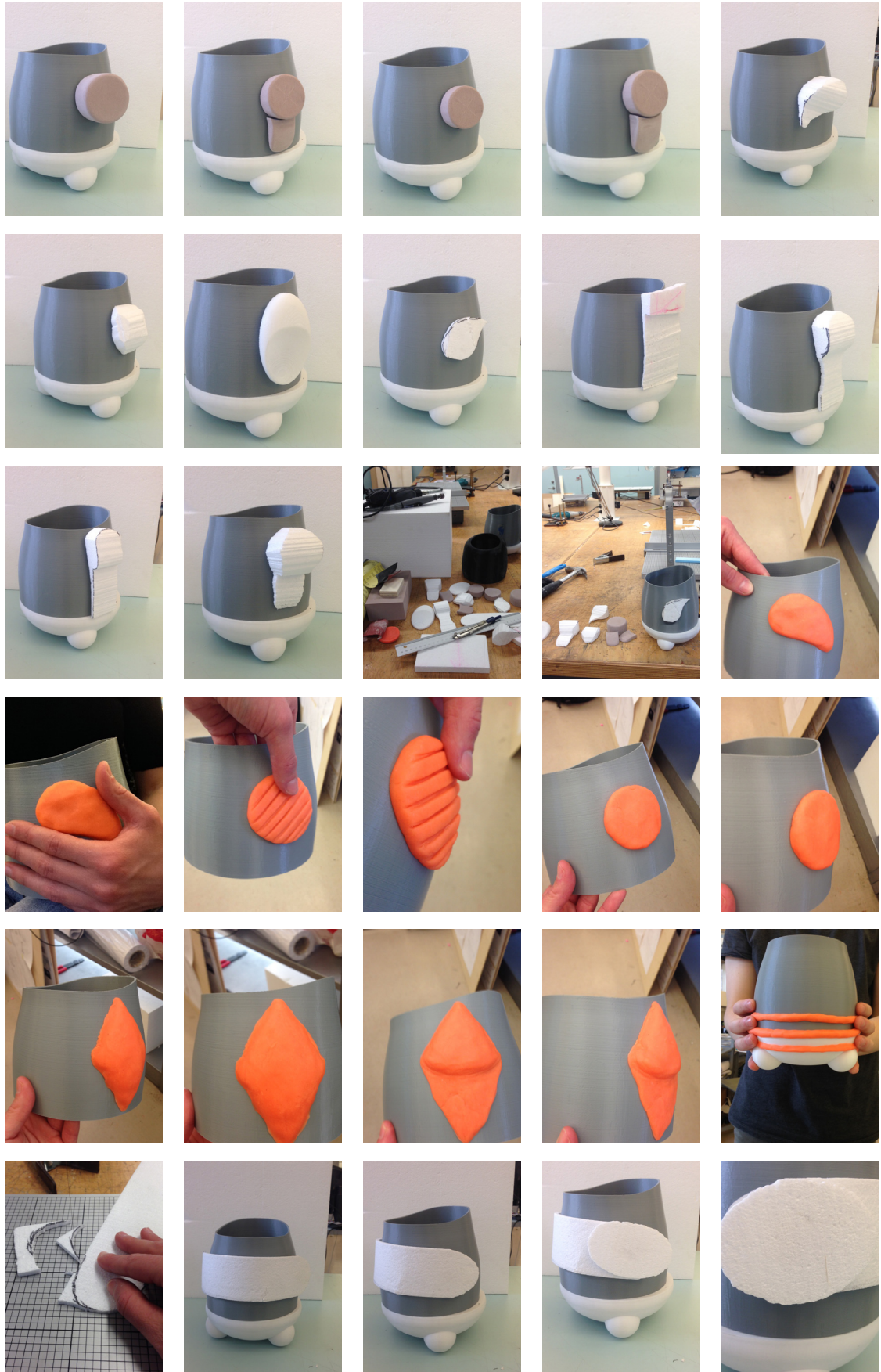

## DEFINING CONCEPT

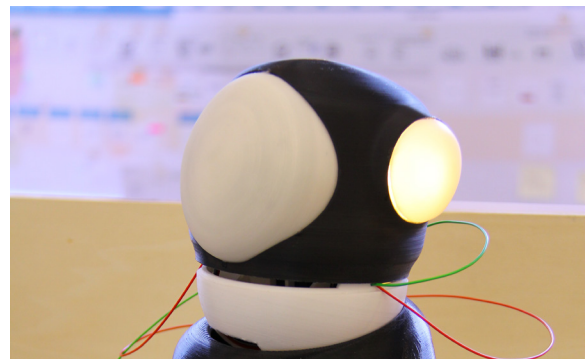

Another main finding we had from our feedback sessions was that the light-up ears we had originally envisioned are too anonymous and subtle, not attracting as much attention as we would have liked.

While working on the grips/arms of the concept, we decided that lighting up the body itself, and not small areas of the head would be a much more effective way of attracting attention. Combining the grips and light up signals would also influence the final shape greatly. Combining lights with one of the concept grips where a large band of textured grip would go around the entire main body of the robot, would give both a large surface for grips, and for lighting up when situated on a desk or classroom.

Based on the testing, we also reimagined the nudge functions to be a specific button, and not tapping the avatar on the head like our concepts had been developed.

**LEFT** A rapid test creating a grip surface using old bike tires

**TOP RIGHT** The tire made a good grip for the hand, but looks rather extreme.

**BOTTOM RIGHT** Indicating attention with light in the "ears" are too hard to notice.



## PROTOTYPING

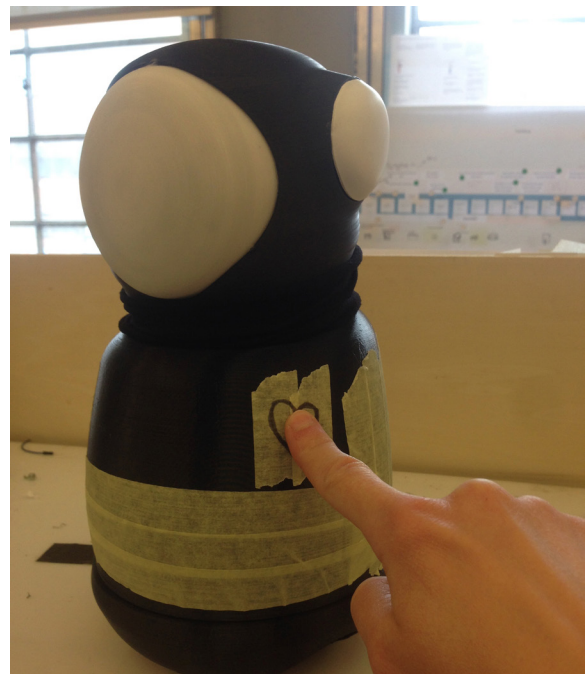
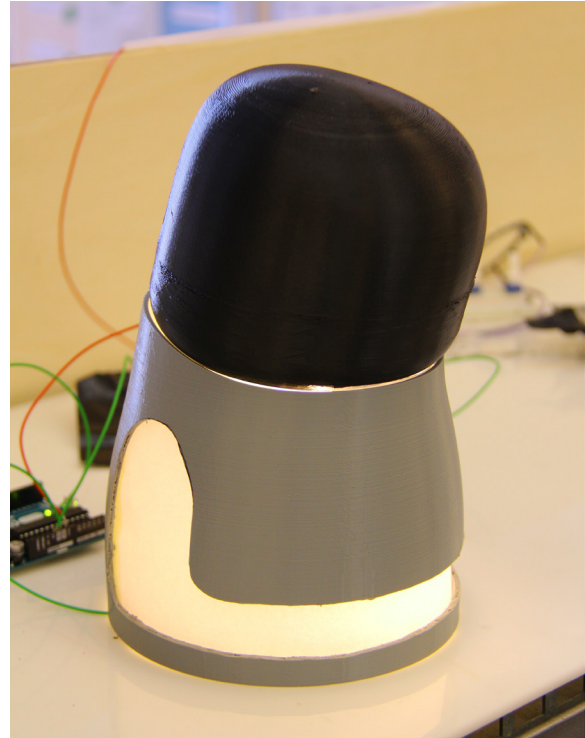

**LEFT TOP** The front of the prototype. Having the neck in a different color created a visual split. Looks like a "helmet".

**LEFT MIDDLE** Lifting opportunities

**LEFT BOTTOM** Marking up a front area for the grip, "arms" to grip and the nudge button "heart".

**TOP RIGHT** New placement of indicating modes with light in the grip sections.

**BOTTOM RIGHT** Press the nudge button, need a response to interaction, light?

# TESTING/FEEDBACK

**We invited Åslaug (a teacher for 1st to 10th graders, mainly 7th graders) and Kari (previously a substitute teacher, in 1st to 10th grade) to test the AV1 first and then our concept model.**

They had both seen the AV1 and talked about the commercial from TV (Telia Stories) they thought it was cute in real life, but quite small and when we demonstrated the different functions they got very engaged. However they did not notice the question modus when we turned that on and they did not see it as a robust product to bring out on excursion as they had seen on TV,

We introduced our concept model and explained the concept with the new interaction of the nudge button. They were very positive and could see how this would be a positive way of giving a discrete encouragement to the child to log on with the avatar.

" A child might not care to know he/she's missing out of a science class but getting a heads'up if its something fun happening is something I think would be very fun for the child being away."

- Åslaug

During this feedback session our goal was to see if the nudge button was a positive addition, how well they would read and respond to our new information-concepts, and to see how they responded to the AV1, and our other proposed solutions.



## TEACHER FEEDBACK



**BOTTOM** Aslak showing our model and drawings.

**TOP** Tea introducing the concept behind the AVI and explaining the functions.

# INSPIRATION

Making moodboards, or inspiration collages helped us define the general aesthetics of our final concept before final drawings or models would be created.



**INFORMATION BUTTONS**  
Tactile, symbols, embossed



Subtle, not showing light unless pushed to give you information when wanted. sunk down to not get pushed unintended.



**SCREEN**  
White screen for face, light up and eyes are higher intensity and different options.

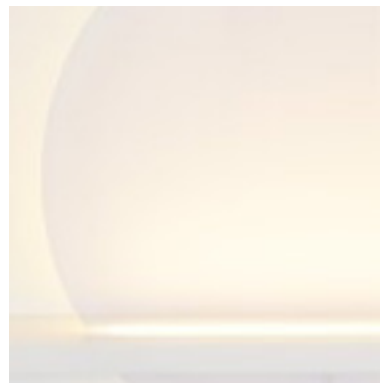

**LIGHT**  
Using colors and different intensity to indicate different moods and functions

## DEFINING CONCEPT



**GRIP** A surface that allow you to hold the avatar without being afraid of loosing it.

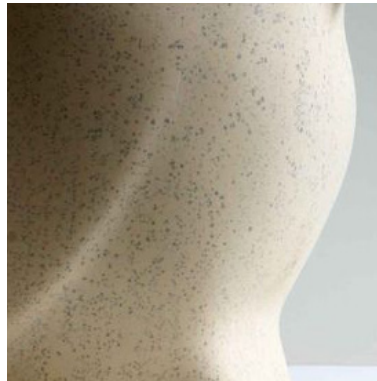

**DETAIL EDGE**  
Discrete but functions after needs, fitting the hand of a child as well as an adult.



**SOFT TRANSITIONS**  
Good to touch, easy to clean.



**FLEX TOP** taking in use flexi material on top part, allowing for human alike motion in neck, rubber/textile

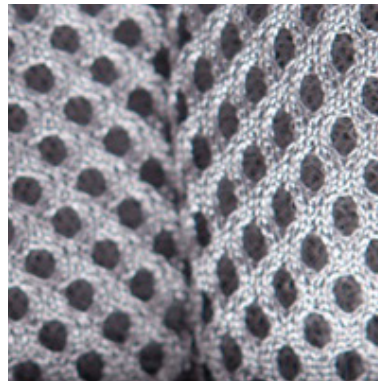

Soft, for protecting the technology but a nice meeting to the body holding it.

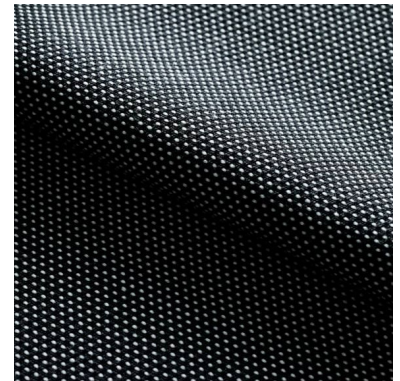

Strong for not being unsanitary and easy to take of and put in the washing-machine when needed.



**MATERIAL MEETING** merging, and all after needs, plastic for grip, textile close to body....

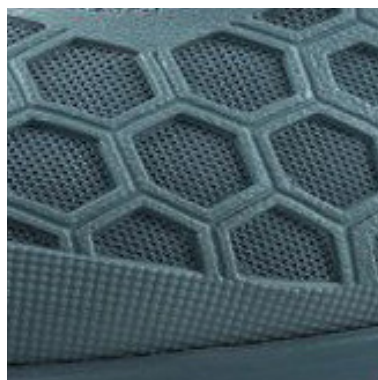

**TRANSITIONS**  
Between hard and soft

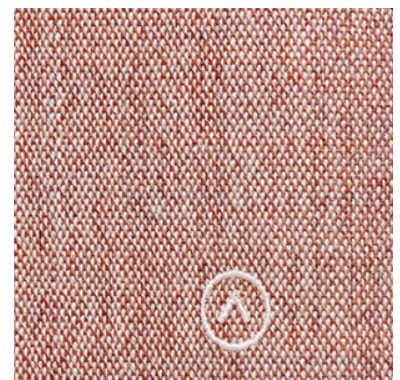

**Marked**  
Nudge button?

# 3D CAD ITERATIONS

Modelling out concepts in a 3D CAD program lets us quickly generate iterations and tweak our solutions. Going back and forth between a digital and several physical models through 3D printing helps us easily get a good feeling of the shapes and sizes we are working with. Working like this, we have constructed several hundred versions of the digital model, each time tweaking small things improving the overall quality.

From the CAD model, we have also been able to test out different visual and tactile appearances of different surfaces and materials, before having to realize them in a physical prototype.

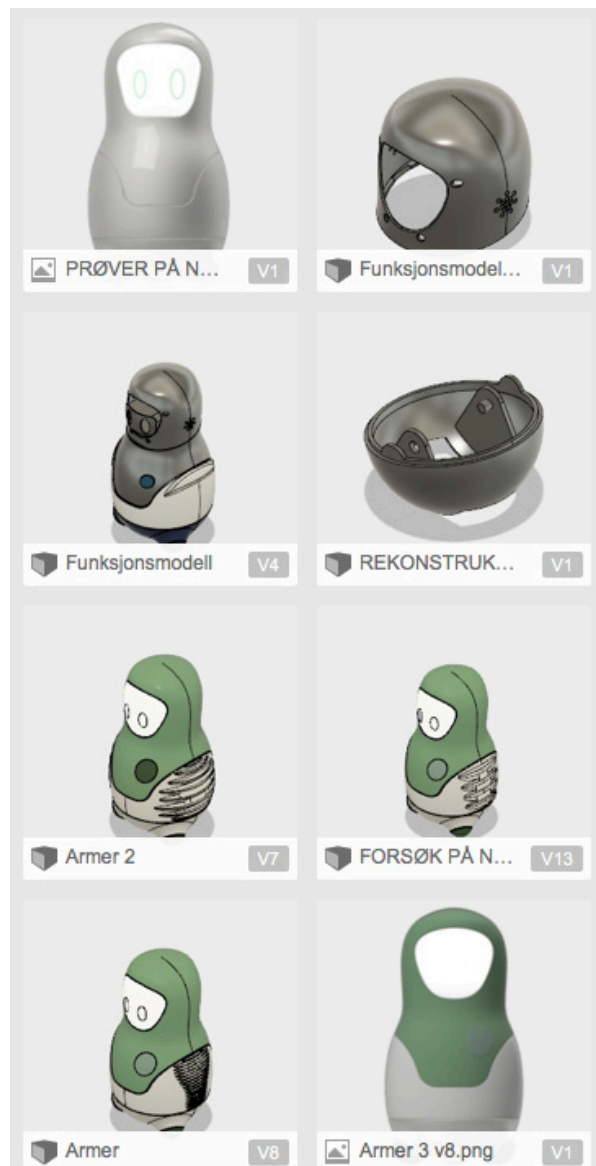



## DEFINING A FINAL SHAPE

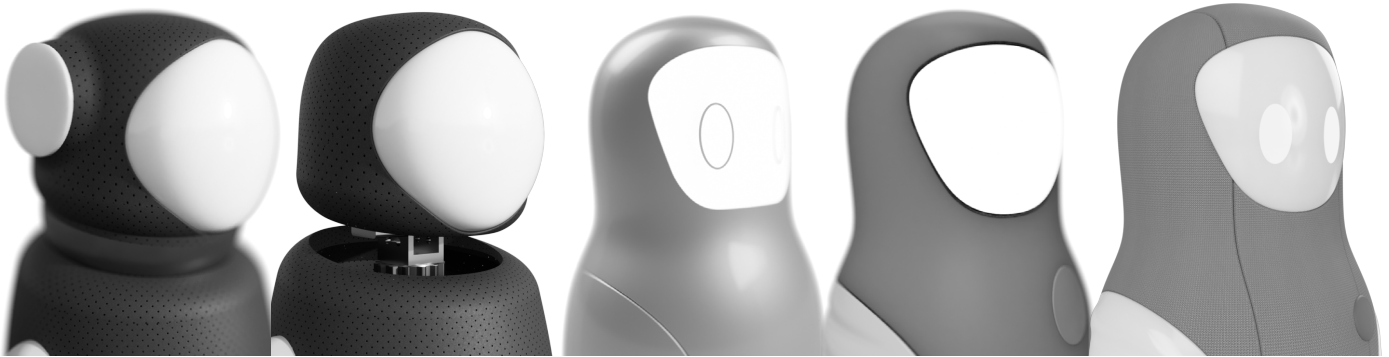

Chronological Iterations showing improvements in the face and head. Moving away from a rounded face insert to a sleeker humanoid visor shape.

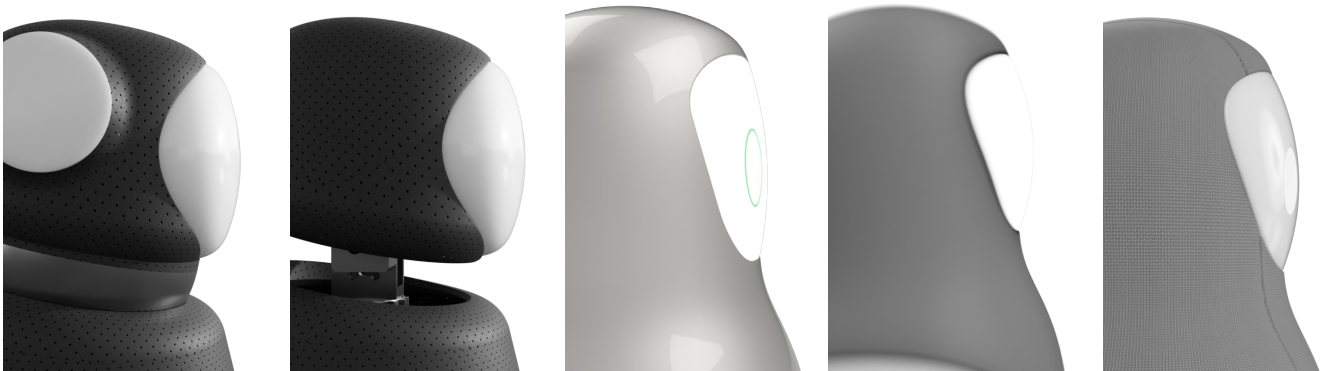

How to hold the avatar has been a major concern throughout our diploma. Solving how you would grip our proposal was therefore tested, prototyped and retested multiple times, also in CAD.

Having large grip surfaces on the sides gives great grip, but even then there is a slight chance of small slipping upwards, dropping the avatar. Having protrusions on the upper parts of the grips will prevent this, helping to hold the avatar in a steady grip, never fearing for its safety.

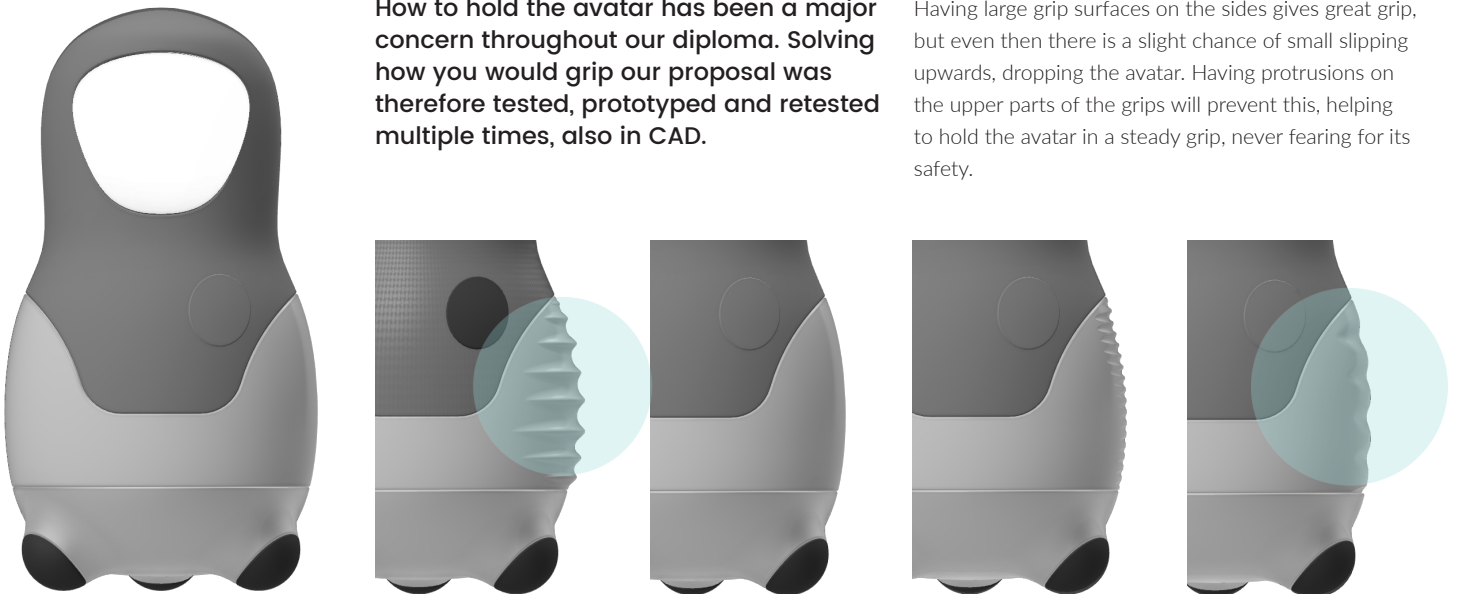



# PHYSICAL MODELS



**Exploring what type of tactile flexible surface the robot should have was very important to the development of the final concept.**

Being able to build models fast based on the CAD models we had made, and iterate on them physically by changing patterns and types of textile helped us gain an understanding of how it would feel, and how it should feel at the end.

At the end, by having continuously updated physical models we could also check with class peers what they thought, not having to explain every choice, but instead showing and letting them feel the surface of it.

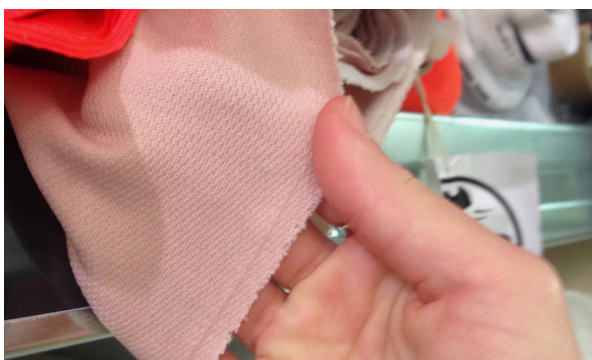

DEFINING A FINAL SHAPE







PICTURE The Avatar fits perfectly in a child's backpack.



# 6

## DESIGN PROPOSAL

IN THIS CHAPTER:

We will present our design proposal for a new robotic avatar. This is not a finalized solution, but a concept that demonstrates how we think many of the problems facing the current solution can be solved.

While we have not solved every detail, we see our proposal as a radical new direction in which to take the robot avatars of No Isolation, challenging most of the current conventions and solutions.

# THE AVATAR

## OUR DESIGN PROPOSAL

The AM8 is an avatar representative for children whom suffer from long term illnesses, and whose regular movements between the home, school and other social occasions is restricted. The avatar allows the child to stay connected and interact in situations they are unable to attend in person. Acting as a communication tool, the avatar affords the child possibilities to see, hear and speak through an app, staying involved and included every step of the way.

The AM8 can be used by teachers, family members, friends and fellow students, with no limits as to where the avatar can go.

For the avatars main use in educational settings, clear signals can be seen if in passive mode, or if questions want to be asked, gaining the attention of secondary users surrounding the AM8. Secondary users can also gain the attention of the primary user using the 'Nudge' button. By pressing this button a push notification will be sent to the users smartphone informing them that their presents is requested.

Through the app the primary user can pilot the avatar, turning the head 40 degrees in each direction and rotating the entire main body 360 degrees to cover all angles in all situations.

All of this encased in a customizable body with smooth, soft edges, textured materials and a expressive friendly face.



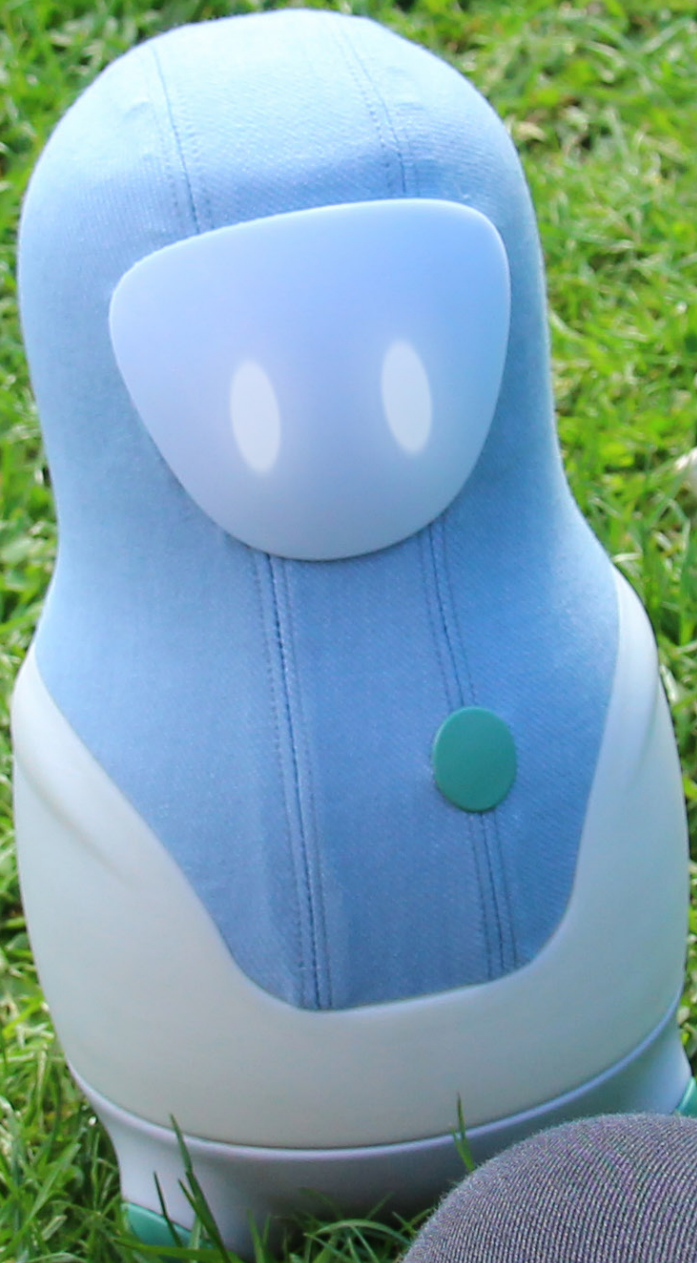



## DESIGN PROPOSAL

We made a little story line to show how the AM8 can be used. Here it is used by one of the typical primary users Lisa from our info mapping in a previous chapter.



This is Lisa, she is 12 years old. Lisa has ME/CFS. She's been away from school for several long periods during the last two years due to her illness. By using her avatar, "Little L" in school and with friends/family, she feels less lonely while stuck at home, and feels like she hasn't missed out when she goes back to school.

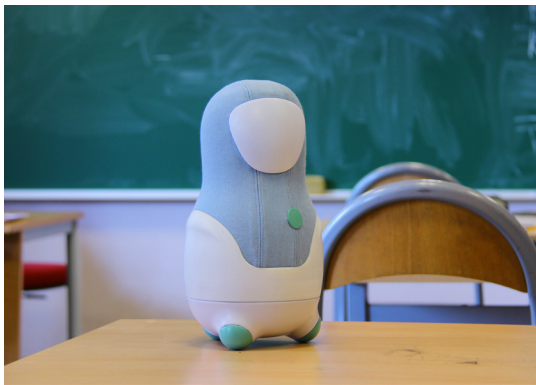

Every morning, "Little L" gets put on her desk by her teacher, patiently waiting for Lisa to log on.



When Lisa logs on "Little L", the first thing she sees is her friend Sally, sitting next to her.

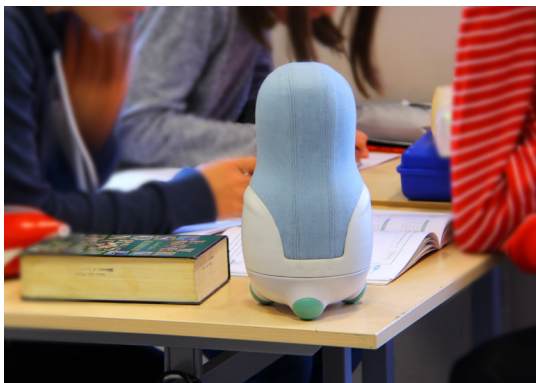

When the class has group work "Little L" joins a group, just as Lisa would if she was there. Lisa helps her friends do their math homework together.



They are a bit unsure of how the task should be solved and they have little discussion. "Little L" is easy to pick up, joining the conversation.

## THE AVATAR



After school Sally brings "Little L" with her in her backpack to the park to meet their friend Nena for ice cream and some gossip.



Lisa is not logged but they would love to show Lisa a cute guy sitting next to them, so they push the nudge button.

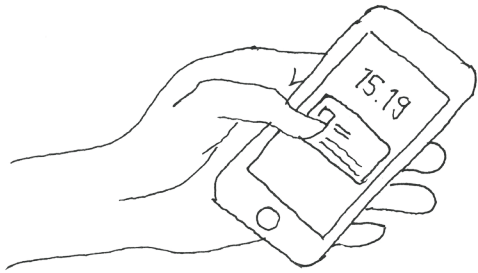

Lisa gets a little notification on her smartphone, notifying her that someone wants to talk to her. Lisa logs on out of curiosity to know what's happening.



She sees Sally and Nena eating ice cream and says "hi!"



They tell her about the boy and Lisa smiles and asks if they could "discreetly lift me so I can have a peek!"



This is what Lisa likes about having an avatar. Friends can easily bring it with them so she won't miss out on all the fun she would otherwise never be a part of. She would not miss it for the world.



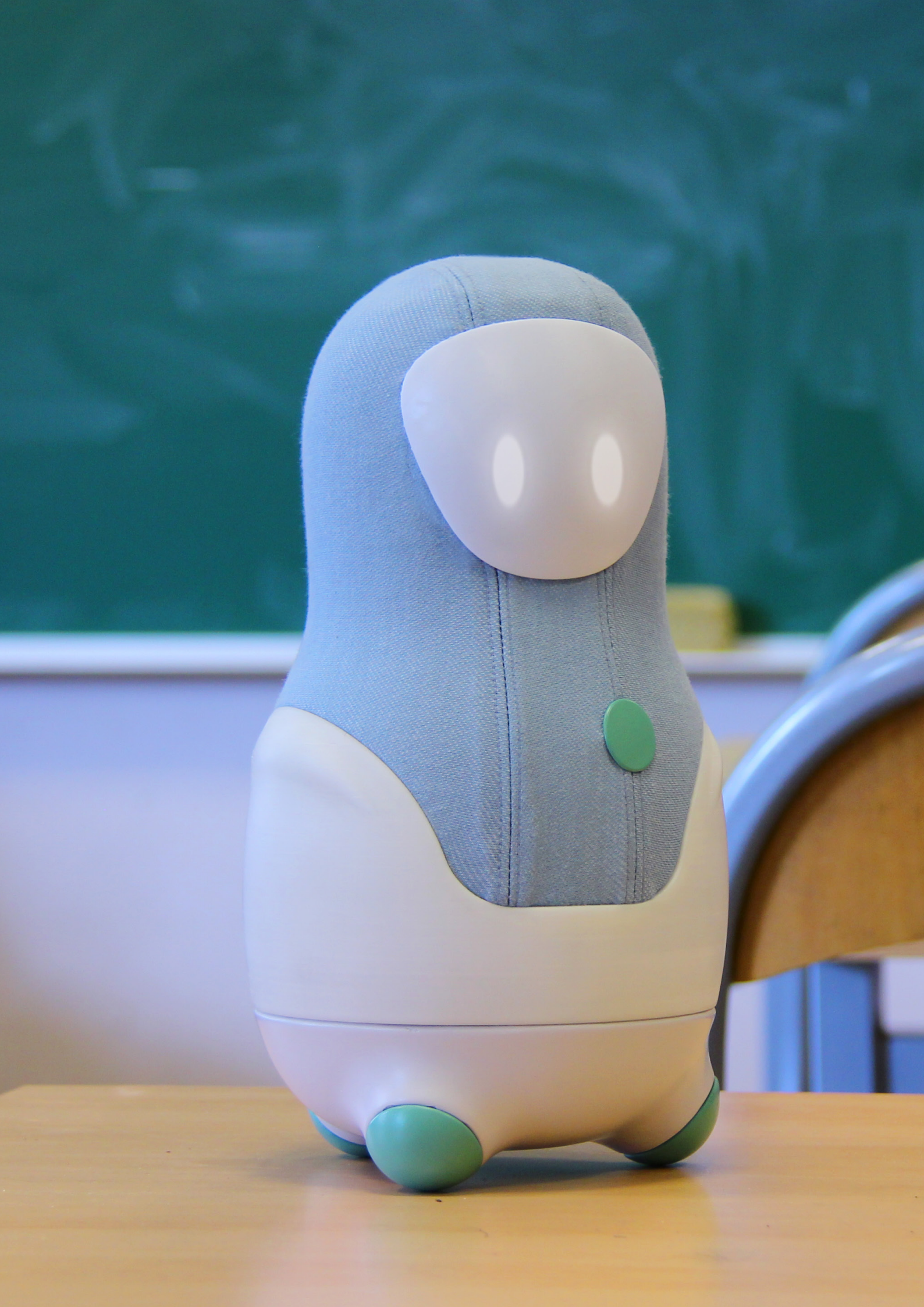



## THE AVATAR MATE

# AM8

### The AM8 is our redesign of the AVI from No Isolation.

The Avatar is a small humanoid robot that stands approximately 28 cm tall. The body of the robot houses all the necessary electronics, a camera, speakers, a microphone, and a battery lasting upwards of 8 hours. Movement in the avatar is made possible with multiple motors enabling 360° rotation at the base, a 40° up and down head movement as well as a 80° horizontal neck rotation. It weighs approximately 1 kg including all electronics.

Charging is done by docking the avatar in its charging dock, making for easy maintenance and use.

The Avatar is remotely controlled, through an accompanying app installed on the users personal smart device, such as a smartphone or a tablet. Through the app the user can turn the robot on, look around through the movement and rotating of the avatar's movements, and communicate with teachers, friends and family on the receiving side. Friendly eyes allow the user to send "emojis" from his/her phone, responding with facial expressions to events surrounding the Avatar.

To indicate passive participation, a ring around the lower main body lights up in two pulsating complementary colors (cyan and magenta). To indicate questions or active participation the whole main body lights up in 4 bright consecutive flashes, then settling on a constant light for 10 seconds or until the light is turned off from the app.

The physical shape of the Avatar invites classmates to easily pick the avatar up and carry it to places such as the schoolyard during breaks or on class excursions so that the user can participate in extracurricular activities along with friends. Users can easily grip and handle the Avatar by its grip surfaces, not needing to fear dropping it by accident. If the worst happens, the construction of the Avatar is made to roll and withstand damage. Rubber and soft materials absorb impacts, reducing the risk of breaking. Along with an integrated 4G connection lets

the user participate, no matter how high or low the Avatar goes.

To reflect the users personality, the Avatar can be ordered in different colors and textures, opening up for highly personalized avatars, for every personality and age.

#### TECHNICAL SPECS THE AVATAR

- WEIGHT - 1,2KG
- DIMENSIONS - 27.8 CM X 17.5 CM X 12.9 CM
- BATTERY - ABOUT 1 SCHOOL DAY OF USE (8 HOURS)
- CAMERA - 13 MP, 77.6° ANGLE, AUTO FOCUS, 360° ROTATION, 40° UP / DOWN AND TO RIGHT / LEFT
- AUDIO - SPEAKERS WITH CLEAR SOUND FOR VOICE
- CONNECTION - BUILT IN WI-FI AND 4G
- CONTACT BUTTON FOR NOTIFICATION TO USER OF APP.
- TWO AXIS OF MOVEMENT, HORIZONTAL & VERTICAL CAMERA MOVEMENT.
- LIGHTWEIGHT CHASSIS MADE FROM 3D PRINTED NYLON, TRANSLUCENT RUBBER PLASTIC, AND TECHNICAL TEXTILE OR FLEXIBLE SILICONE.
- AVAILABLE IN A WIDE SELECTION OF DIFFERENT COLORS ON BOTH THE PLASTIC PARTS AND THE TEXTILE.

# FEATURES

To answer the challenges we saw in the AV1, our Avatar has been redesigned from the ground up to solve the issues faced in the previous edition.

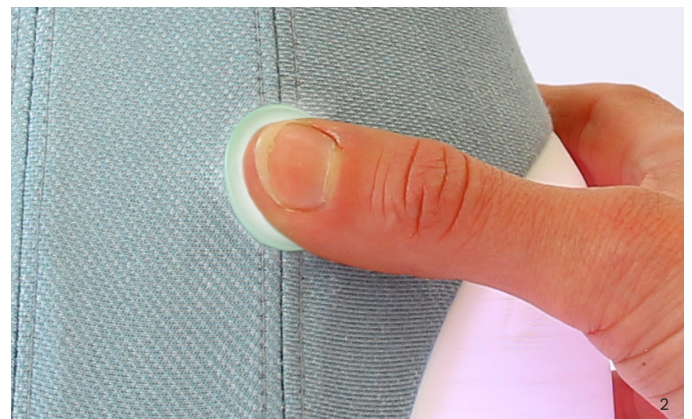

1

## BUTTONS

Much of the information you can get from the avatar is not required regularly. We have moved the information to the back, available on demand.

Battery and connection information can easily be read by pressing their respective buttons.

These buttons will then pulse in one of three colors;

Red -v Battery Low, Bad Coverage.

Yellow - Mid Life Battery. Varying coverage.

Green - Fully Charges Battery.

Good Coverage.

More information about coverage can also be accessed through the companion app.

2

## NUDGE BUTTON

Giving the secondary users a discreet way of contacting the sick child, even when he or she is not logged on, is not a part of today's solution.

The Avatar has a "nudge" button, that when pressed sends a push notification to the sick child's tablet or phone, notifying that someone wants to talk or show them something. It's a symbolic placement on the left side as the human's heart, it will lit up when pressed and fade out over 2 minutes

This can be overlooked, or acted upon according to the child's health.

3

## STABLE FEET

Bringing the AV1 where you want means it has to be stable wherever you put it down.

Rounded tripod feet made from rubberized plastic secures a stable position, no matter where the avatar goes.

4

## ONE HANDED GRIP.

The middle part of the avatar is made in 3D printed translucent rubber, creating a surface you can hold around with one arm and carry it with you.



# THE AVATAR

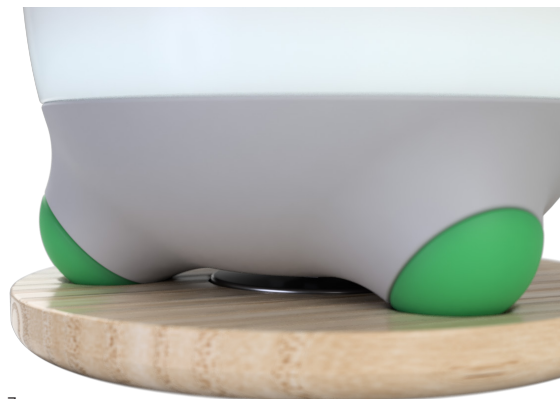

5

## TWO HANDED GRIP!

While the avatar can be held with one hand, a two-handed grip is a lot better. The avatar's ergonomic design makes it easy to hold, and the material makes it hard for your hands to slip. Holding the avatar like this ensures that the avatar is facing the right way, and the primary user has a proper field of view.

6

## MATERIALS

We made a conscious choice of using 3d print in different materials and textiles/ silicon to solve some of the issues found in the AV1. A soft top in textile/silicon makes it pleasant to touch, while also protecting the innards from damage from falls and drops.

We see the top part made in textile or silicon and being connected to the rubber middle part, you separate these two of from the base and wash it if needed.

7

## CHARGING DOCK

To make the daily routine as easy as possible you simply charge the avatar by placing it in the docking station.

8

## LIGHT INDICATIONS

We have kept light as an indicator for the primary user's modes. We have improved the placement and size of the indicator light. The passive mode is a calm pulsing of two colors, and the attention light is a series of flashes (4) before a continuous light that lasts for 10 seconds. We discovered through testing that this is an efficient way to catch the teacher's eye in a class full of raised hands.

Upper Body: Perforated 3Dprinted part is covered in textile or silicon. This is a product you will hold close to your body and the material should be something you would want to keep close. Using textile or silicon gives a soft surface, also protect the shap if it falles and you can easily wash it. It will give the microphone and speaker good quality all 360° around and not be exposed but protected.

Face: 3D printed tranlucent rubber/plastic, lights up when Avatar turns on, creating a distinct face on the Avatar allowing the user to have a clear reference point of a front. Clearly visible from 3 sides, letting peers know it is active.

Camera: Placed behind screen, looking out.

Eyes: Light up when Avatar is on. It has three diffrent expressions: positive, negative and netural. Expressions conveyed controled through app.

Nudge button: Allows the secondary user to send a notification to the primary user "someone wants to talk to you". The botton will light up when pushed, pulsing before fading out. A two way communication to get in touch. Notification on app, primary user can choose to turn on/off notification.

Base: 3D printed plastic. Base connects to body on bearings, allowing body to rotate 360°. When neck fully rotates 40° base rotation takes over.

Tripod: Three "legs" gives the best stability on diffrent surfac- es the avatar will be standing on. They are also the charging parts for the induction charging. Made in 3D printed platic.

Neck: Rotates 40° to the right / left and up /down, covered by the textile/silicone making the motion smooth and human-like.

Neck bent, looking down when logged off, raising head, waking up, when user logs on.

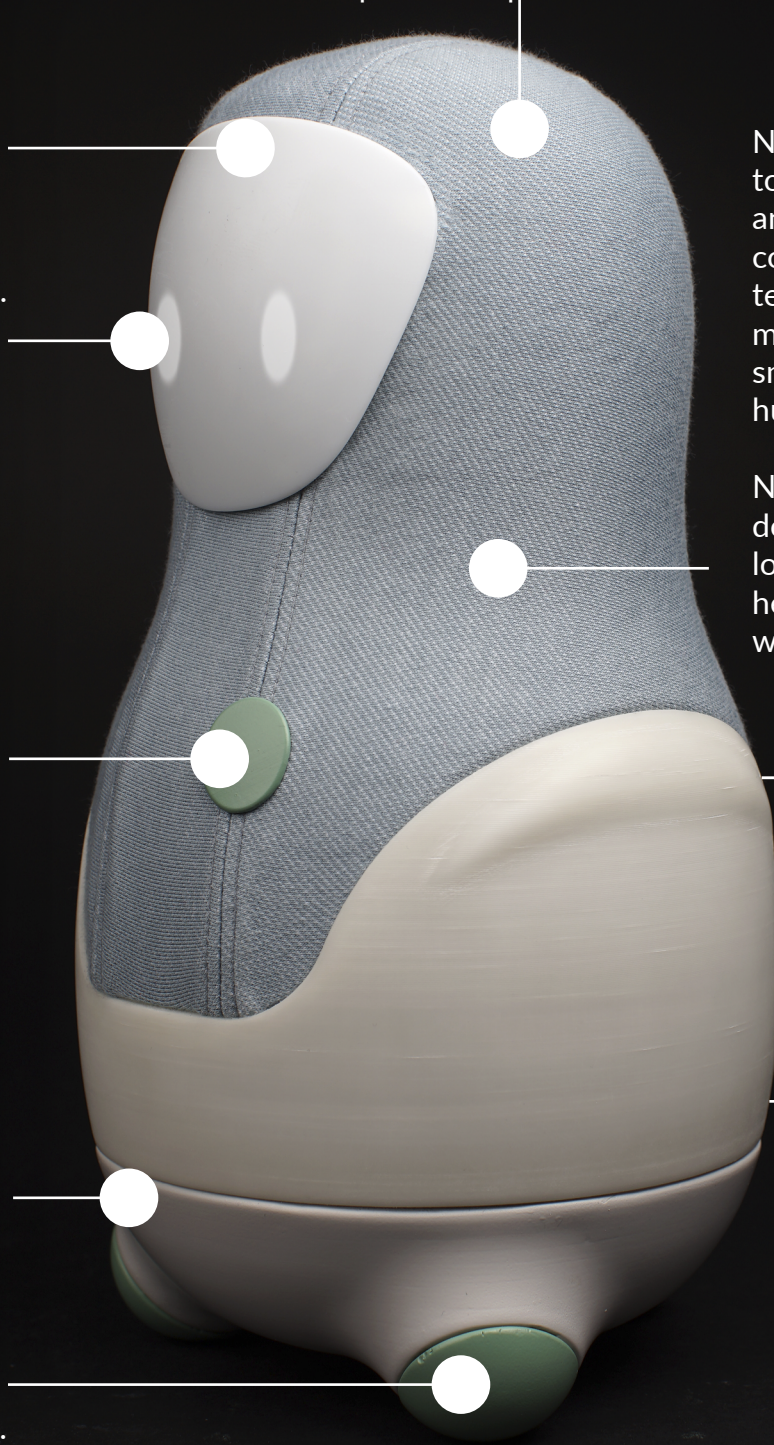



## THE AVATAR

- Controlled remotely by user, using an app on phone or tablet.
- Connected by WiFi or 2G, 3G and 4G.
- Direct streaming, this data is encrypted; both out and at the receivers side.
- Password required to log on.
- No recording, screen-shots are restricted
- A guardian must also approve that only the user him/herself will be able to connect to AV1 before being granted access. If a guardian should log on with the AV1 is therefore a breach of contract, leading to termination of the agreement.
- Transport-mode possible, locking all joints, protecting the avatar from shaking and dropping.



In the back you have three buttons;  
-one turning on/off Avatar (only used in special needed situation) press for 4 sec.  
-2G, 3G, 4G and WiFi reception info, press and light will appear; red(none), yellow(poor), green(good).  
-battery level, press and light will appear indicating low/middle/fully charge.



The middle part of the Avatar is made in 3d printed translucent rubber/plastic, that will let light through indicating you want attention or that your participating in a passive mode. Using rubberized plastic will give the user a good grip to carry the Avatar and it will be a surface easy to clean.

Passive participation: A ring around the lower main body lights up in two pulsating complementary colors

Questions or attention:

The whole main body lights up in 4 bright consecutive flashes, then settling on a constant light for 10 seconds or until the light is turned off from the app.

# PERSONALIZATION

**The Avatar is a highly personal item, representing the users where they cannot be. Having a personal avatar means more than just owning one, it should also portray who you are, through colors, textures and personality.**

Upon ordering the Avatar, users are prompted to customize their own personal versions of the robot. Giving users the ability to change nearly all aspects of the visual presentation of the avatar gives users a great way of presenting themselves in just the right way. They can also see what others have done, meeting

other peoples avatars and get inspired, or base their own on what they have done.

Are you a heavy metal fanatic? Choose some black heavy textured textile with a red mohawk stripe running down the middle.

Are you the world's biggest Disney's Frozen fan? Choose a frosty blue with and a snow white base.

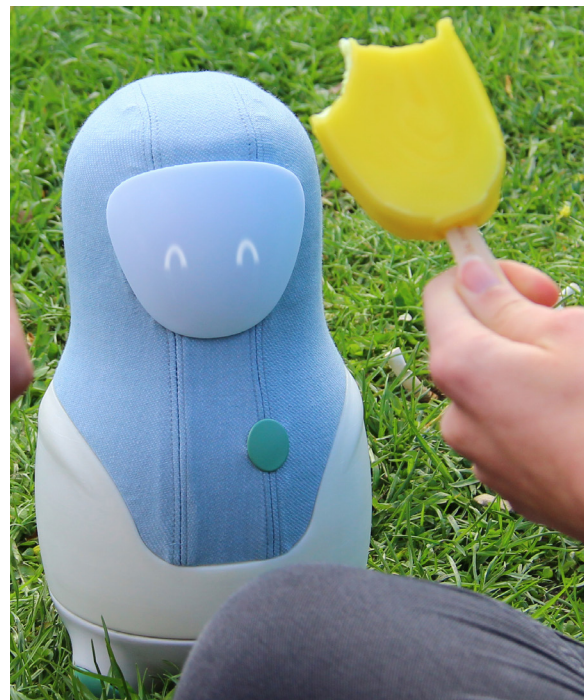

# THE AVATAR

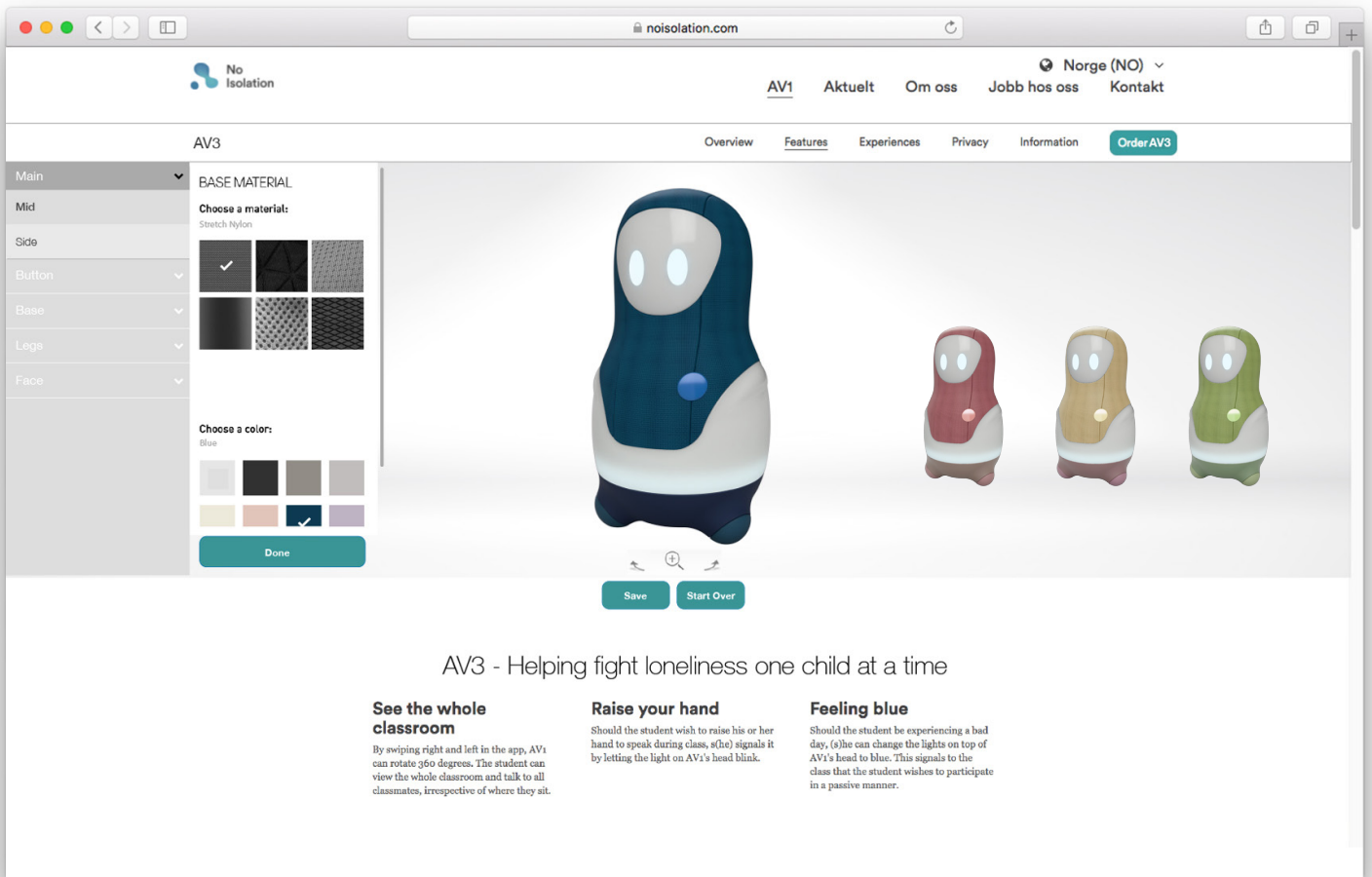

**TOP** Ordering the Avatar from No Isolations web-page.

**BOTTOM 3** Not all Avatars are created equal, just as it should be.

# FUTURE DEVELOPMENTS

**On this diploma we have worked with the startup No Isolation, and we wish to share with them what insight we have gained. It is up to them if they want to use it/parts of it for further development in their business. Most of the following implementations appear in our proposal, but some are things we would like to do if we could spend more time on the project.**

## **App: Teachers**

To simplify things for the secondary users we do see a benefit in designing an app for the teacher or other secondary user to use. This also makes troubleshooting easier, as the app will provide more specific feedback on potential errors, effectively cutting down on time spent figuring out what's wrong and making solutions more obvious.

No Isolation is currently working on a similar application for teachers, and would include and utilize their solution. We would like to work closer with No Isolation looking into the functions needed, and how these would be solved, integrating it with our solution.

## **Test prototype: feedback iterations**

To make progress with our design proposal we would make a fully functional prototype and test it for minimum one month to get feedback, then analyze the feedback and make new iterations. Having tested the AV1 ourselves for a long time, and building on the feedback of the users of the AV1 over the course of 12 months, we see the necessity of testing intricate products like an avatar.

## **Nudge button: encourage and included?**

In our proposal, we have suggested a nudge button, a discreet two-way communication possibility. It will notify the primary user in the app (it is optional to have this function turned on). By this you can let the primary user know that "someone wants to speak to you" and then it's up to the user to log on if desired.

We think this can create a positive influence on the interaction between the two users. We have had many good feedbacks on this new feature, but it would have to be tested out for a long time, and vetted by medical personnel before implementing. We would love to see this tested out, because we believe this could lead to a significantly increased feeling of social inclusion.

## **Facial recognition: Secure login and expressive eyes**

Like the AV1 our Avatar also has eyes. We have three different sets of expression instead of just one as in the AV1. We have then added in the primary user's app where these can be changed. We would like to see if this change could be done by using facial recognition. Implementing facial recognition would also provide added security when logging on. In the AV1 a secure log-on consists of a personal password. A major concern that surfaced during the research and interview phase was "what if someone else is sitting behind that app and can see in to the classroom?" We see facial recognition as a way of making things more secure by checking who is logging on.

## **Production:**

How would the avatar be manufactured?

We envision the parts to be produced using rapidly emerging additive manufacturing methods. The current price tag of the product (about 30.000 Nok) but a relatively low production volume could possibly leave injection molding as a unfavorable production method. Utilizing additive manufacturing, with its low volume production capacity could be a great solution for the production of the AM8. This also opens up for more customizing, not only of colors and textures, but possibly also shapes and volumes. For the flexible textiles, further exploring brand new 3d knitting technologies is possible. Much like shoes or other high performance specific textile products, new technologies could solve many of the production challenges.









PICTURE The finished AM8

# 7 OUR REFLECTIONS

IN THIS CHAPTER:

On the conclusion of this project and this report, we have some final reflections on what we have done, what worked, what didn't and what this has meant for us.

## OUR REFLECTION

### Different people, similar purpose

At various points throughout the process we have been asked about how it is working together, because we are different people with very different backgrounds and interests. In the face of this, we have worked together as a very strong team. It has been a stable process using what we have "collected" of knowledge from 5 years of studying various design topics. Keeping each other motivated when the going got tough and driving the project to new levels.

Both of us see a big value in working as a group, you will always have some to share ideas with or to discuss the project with, and you are never alone about decision making.

Utilizing each others strengths while balancing out each others weaknesses, we believe we have done a project we could never have achieved if we worked alone. Working this way we have together found solutions that will hit home with a much audience than if it was only one of us.

### Working with a collaborator

Throughout the project we have had a open collaboration with No Isolation.

While working with a external collaborator like No Isolation is a great opportunity to learn and work with a real-world business it can also be a challenge.

Before starting this project, neither of us knew anything about No Isolation or their product, leaving us on bare ground when it came to choosing if we wanted to work with them at all.

Not knowing what we could expect from them, we might have been a little too optimistic in our expectations of how involved they would be. This lead to us working more by ourselves without their involvement that we envisioned when originally contacted for the project.

### If we had done this project now, what would we do different.

Now as we are on the very end of our diploma have we sat down and talked about what would we have done differently if we could do this again.

When we look back we do see that we would have wanted to give ourself even more time to observe children in schools. Our project would have been even more balanced out if we could have gotten in touch with the primary users, however we see this as a difficulty due to not wanting to increase and worsen health for them.

If there is one thing we really wished we could have done is started earlier. We were contacted by No Isolation in late December through our supervisor Nick Stevens. Nearly a month after our pre-diploma course was finished. We both had very different projects planned but when we got introduced to this we took a turn and went for it.

Ideally we would have done all of the defining of this project in our pre diploma class and not meeting up after christmas in January and then mapping out our program. Spending the first three weeks of January planning a new diploma was time spent we could have spent interviewing or researching. We would have gotten in touch with the users more rapidly, done users observation sooner, in parallel with the research stage.

### All in all

We genuinely believe that if implemented in No Isolations product line, our ideas and focus, if not the whole project, could impact a lot of peoples lives for the better. Given our focus on the inter human connections, and the closeness of relationships, we believe our product would fill a niche not currently solved by any other product in the market.



## OUR REFLECTIONS

Thank you everyone, we would not have made this without you!

We have many people to thank for making this diploma an exciting project, and something we have learned a lot from and will remember forever.

To all of you sitting in S8 with us at AHO, creating a good atmosphere for working.

To our supervisors, Nick Stevens, Geir Øxseth and William Kempton

To the fantastic Workshop Masters at AHO,

To No Isolation for a great collaboration throughout the semester.

To Jorun and Alma for all your fantastic insights.

To all of you giving us important information and insights; Lene, Finn Even, Heidi, Åslaug, Kari, Martin, Anne Karin, Suzanne, Birk, Ylva, Tea Oleana, Karen, Sondre, Irma, Henrik, Hannah, Benjamin, and Ralf.

We have probably many more to thank, so all we can say is a BIG thank you and we highly appreciate all of it.

# 8

# REFERENCES

& READING LIST

Throughout the entire project, we have tried to anchor our findings and concepts in other research and literature.

What follows is a complete reference and reading list for our project: "The Avatar"

Anna Holm Heide, 2017. Debatt: Teknologi - Robot hjelper over 150 barn å delta i skolen. Dagbladet. Available at: <http://www.dagbladet.no/kultur/robot-hjelper-over-150-barn-a-delta-i-skolen/66932222> [Accessed May 11, 2017].

Annie Jin, S.-A., "It Feels Right. Therefore, I Feel Present and Enjoy": The Effects of Regulatory Fit and the Mediating Roles of Social Presence and Self-Presence in Avatar-Based 3D Virtual Environments.

Åsbring, P. & Närvänen, A.-L., Women's Experiences of Stigma in Relation to Chronic Fatigue Syndrome and Fibromyalgia.

Balkind, N., Animation Comes to Life: Anthropomorphism & Wall-E.

Behm-Morawitz, E., 2012. Mirrored selves: The influence of self-presence in a virtual world on health, appearance, and well-being. COMPUTERS IN HUMAN BEHAVIOR.

Børsting, J. & Culén, A.L., 2016. A ROBOT-AVATAR : EASIER ACCESS TO EDUCATION AND REDUCTION IN ISOLATION ? , (September 2015).

Bremner, P., Celiktutan, O. & Gunes, H., 2016. Personality perception of robot avatar tele-operators. ACM/IEEE International Conference on Human-Robot Interaction, 2016-April(March), pp.141-148.

Brian R. Duffy, 2003. Anthropomorphism and the social robot.

Dalibard, S., Magnenat-thalmann, N. & Thalmann, D., 2012. Anthropomorphism of artificial agents : a comparative survey of expressive design and motion of virtual characters and social robots. Computer Animation and Social Agents (CASA), (Casa), pp.1-20.

David S. Bell MD, ME/CFS in Children. Available at: <http://www.prohealth.com/library/showarticle.cfm?libid=28892> [Accessed January 24, 2017].

## REFERENCES

- de Lourdes Drachler, M. et al., The expressed needs of people with Chronic Fatigue Syndrome/Myalgic Encephalomyelitis: A systematic review.
- Duffy, B.R., 2003. Anthropomorphism and the social robot. *Robotics and Autonomous Systems*, 42, pp.177–190.
- Edith Nybakk, 2017. Debatt: Roboter - Skal vi tillate videoovervåking i norske skoler? *Dagbladet*. Available at: <http://www.dagbladet.no/kultur/skal-vi-tillate-videoovervaking-i-norske-skoler/66922647> [Accessed May 11, 2017].
- Even Lusæter & Knut-Øyvind Hagen, 2017. Emma (10) fekk uventa robothjelp. NRK Hedmark og Oppland - Lokale nyheter, TV og radio. Available at: [https://www.nrk.no/ho/emma-\\_10\\_-fekk-uventa-robothjelp-1.13225522](https://www.nrk.no/ho/emma-_10_-fekk-uventa-robothjelp-1.13225522) [Accessed May 11, 2017].
- Fussell, S.R. et al., How People Anthropomorphize Robots.
- Gavrilova, M.L. & Yampolskiy, R., 2011. Applying Biometric Principles to Avatar Recognition. *Trans. on Comput. Sci. XII LNCS*, 6670, pp.140–158.
- Granly, A. & Johansson, S., 2007. Film kobler mennesker. AHO Master Thesis.
- Guy Hoffman, 2013. Robots with “soul.” In TED Talk. Available at: [https://www.ted.com/talks/guy\\_hoffman\\_robots\\_with\\_soul](https://www.ted.com/talks/guy_hoffman_robots_with_soul) [Accessed January 18, 2017].
- Hooi, R. & Cho, H., 2012. Being immersed: avatar similarity and self-awareness. *Proceedings of the 24th Australian Computer-Human Interaction Conference*, (November 2012), pp.232–240. Available at: <http://dl.acm.org/citation.cfm?id=2414536.2414576&coll=DL&dl=ACM&CFID=556508679&CFTOKEN=31085299>.
- Isolation, N., 2016. Oppsummering av Pilot 5x5.
- Isolation, N., Culén, A.L. & Børsting, J., 2017. Experiences with a Research Product : A Robot Avatar for Chronically Ill Adolescents.
- Johnston, O. & Thomas, F., 1995. *The Illusion of Life: Disney Animation*,
- Ki Lee, J. et al., 2008. The Design of a Semi-Autonomous Robot Avatar for Family Communication and Education.
- Kyle Mathews, Bricolage | What are Social Objects? Available at: <https://www.bricolage.io/what-are-social-objects/> [Accessed January 16, 2017].
- Lombard, M. & Ditton, T., 2006. At the Heart of It All: The Concept of Presence. *Journal of Computer-Mediated Communication*, 3(2), pp.0–0. Available at: <http://doi.wiley.com/10.1111/j.1083-6101.1997.tb00072.x> [Accessed January 13, 2017].
- Margareth Rodes, 2017. The Touchy Task of Making Robots Seem Human—But Not Too Human. *WIRED*. Available at: <https://www.wired.com/2017/01/touchy-task-making-robots-seem-human-not-human/> [Accessed January 24, 2017].
- Mehrotra, S. et al., 2016. Embodied Conversational Interfaces for the Elderly User. In *Proceedings of the 8th Indian Conference on Human Computer Interaction - IHCI '16*. New York, New York, USA: ACM Press, pp. 90–95. Available at: <http://dl.acm.org/citation.cfm?doid=3014362.3014372> [Accessed January 16, 2017].
- Mike Pearl, 2017. How Scared Should I Be of the Internet of Things? *VICE*. Available at: [https://www.vice.com/en\\_se/article/how-scared-should-i-be-of-the-internet-of-things](https://www.vice.com/en_se/article/how-scared-should-i-be-of-the-internet-of-things) [Accessed January 16, 2017].
- Morie, J.F. et al., Virtual Worlds and Avatars as the New Frontier of Telehealth Care.
- Nishio, S. et al., 2016. Iconic Gestures for Robot Avatars, Recognition and Integration with Speech. *Frontiers in Psychology Front. Psychol*, 7(7).
- Paul Ekman, 1992. An Argument for Basic EMotions. Available at: <http://server2.docfoc.com/uploads/Z2015/12/01/dkj9U2srfd/8bbd3af747461c86a17e9f8be45f191b.pdf> [Accessed May 9, 2017].
- Roche, J. & Tucker, S., 2003. Extending the Social Exclusion Debate: An Exploration of the Family Lives of Young Carers and Young People with Me. *Childhood*, 10(4), pp.439–456. Available at: <http://chd.sagepub.com/cgi/doi/10.1177/0907568203104004%5Cnhttp://resources.library.brandeis.edu/login?url=http://search.ebscohost.com/login.aspx?direct=true&db=aph&AN=11802593&site=ehost-live&scope=site>.
- Samani, H., 2016. The evaluation of affection in human - robot interaction. *Kybernetes*, 45(8). Available at: <http://www.emeraldinsight.com/doi/abs/10.1108/K-09-2015-0232>.
- Sara Johansson, 2007. SNIFF Tangible Toy for visually impaired children.



Scheeff, M. et al., Experiences with Sparky, a Social Robot.

Sekiguchi, D., Inami, M. & Tachi, S., RobotPHONE: RUI for Interpersonal Communication.

Weerdesteijn, J. & Gielen, M., 2004. Playing With Body Language and Emotions. Studiolab.io.Tudelft.Nl, pp.1-9. Available at: <http://onlinelibrary.wiley.com/doi/10.1002/cbdv.200490137/abstract%5Cnhttp://studiolab.io.tudelft.nl/manila/gems/gielen/Playingwithbodylanguage.pdf>.

Yamen Sarajji, M. et al., Real-time Egocentric Superimposition of Operator's Own Body on Telexistence Avatar in Virtual Environment.

Yee, N. & Bailenson, J., The Proteus Effect: The Effect of Transformed Self-Representation on Behavior.

Zlotowski, J. et al., 2016. Appearance of a Robot Affects the Impact of its Behaviour on Perceived Trustworthiness and Empathy. *Paladyn, Journal of Behavioral Robotics*, 7(1), pp.55-66. Available at: <http://www.degruyter.com/view/j/pjbr.2016.7.issue-1/pjbr-2016-0005/pjbr-2016-0005.xml>.

Anon, Senter for IKT i utdanningen. Available at: <https://iktsenteret.no/> [Accessed February 15, 2017].

Anon, 5 Reasons to Fear Robots. Available at: <http://www.livescience.com/18641-reasons-fear-robots.html> [Accessed February 3, 2017].

Anon, Human-Robot Relations: Why We Should Worry | Sherry Turkle. Available at: <http://www.livescience.com/27204-human-robot-relationships-turkle.html> [Accessed February 3, 2017].

Anon, Real-world beaming: The risk of avatar and robot crime - BBC News. Available at: <http://www.bbc.com/news/world-europe-17905533> [Accessed January 16, 2017].

Anon, Use and benefits of Avatars in virtual learning | Aspin eLearning. Available at: <http://www.aspinelearning.com.au/content/Use-and-benefits-of-Avatars-in-virtual-learning> [Accessed January 13, 2017].





