

Process

The House of Photography
Amanda H. J. Solberg

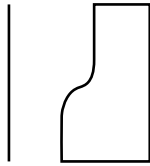

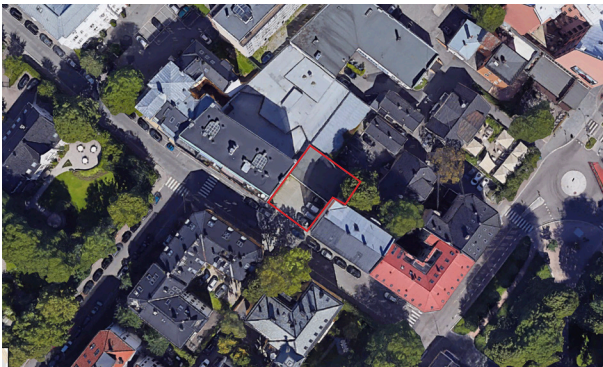

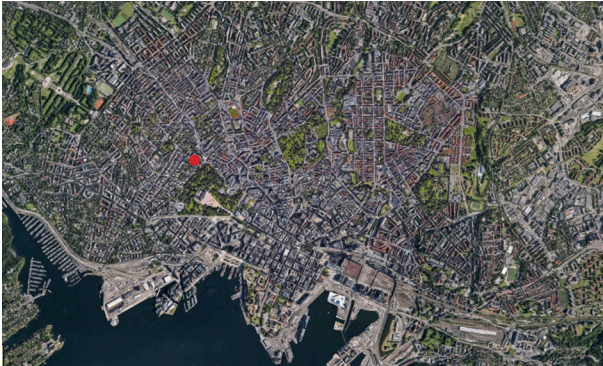



*Fitting the pieces into a set square
using only undefinable objects, filling
the space.*



Breaking up an existing image, adding new facade elements. The break/cut revealing something hidden that was in the image all along.



Which way is up? Challenging the definition of the right rotation and direction of things. Creates in a perspective-like street.



*Framing elements framing elements.
Beam, roof, construction and railing
framing floor, ceiling, walls, windows
and corners.*

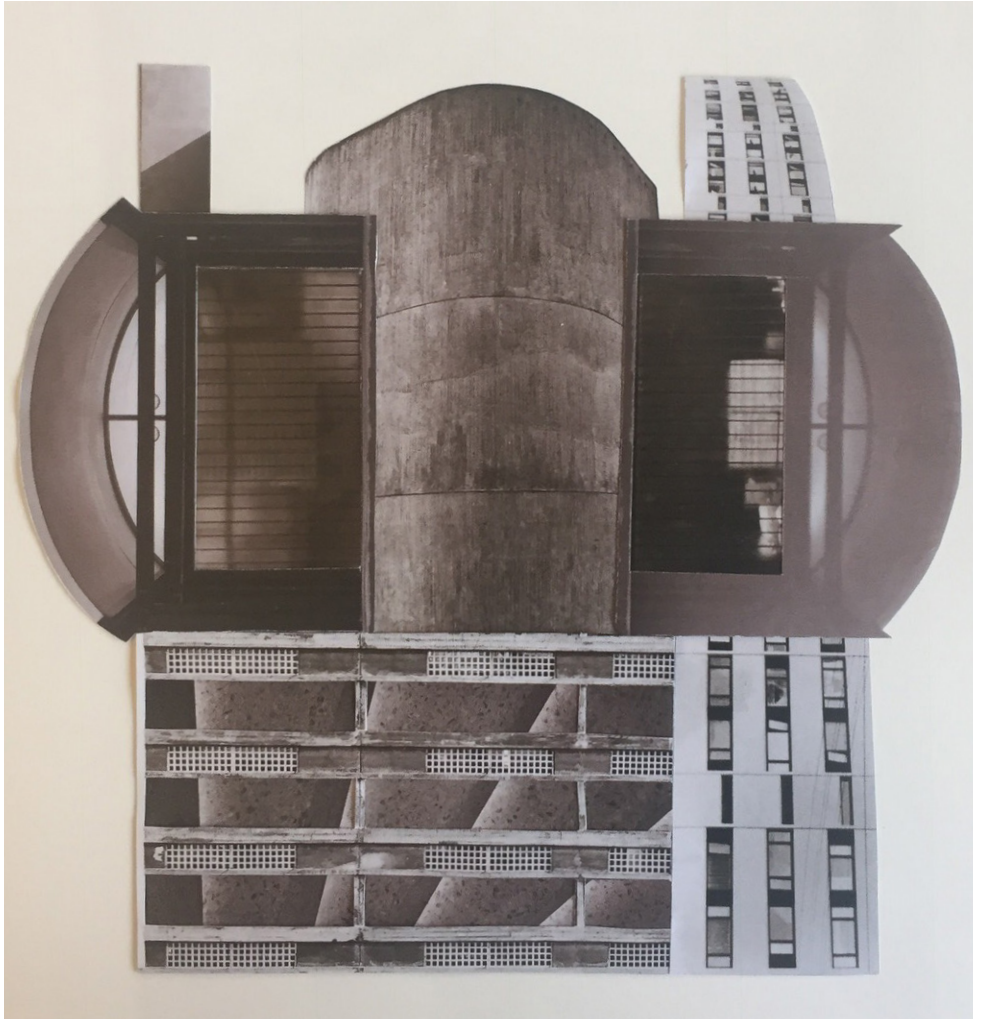

Filling the gaps. Cutting the pieces in their "natural" gap, filling it with a new content.



Involving nature elements that could belong, challenging the perspective of the architectural elements.

The site model is made in scale 1:200.
This scale came natural to be used for
volume and light studies.



Dividing the program into two parts. The creation of photography and the display of photography.

When moving around in one of the sections, one is able to move undisturbed to the other parts of the section through a vertical communication. There can still be communication between the two sections on the horizontal communication. By visual communication, physical communication or shared spaces.

Other times the sections will be completely separated where it is necessary.

The three studies show different design and placement for the vertical communication. One where they are as far away from each other as possible, one where they are quite centred in the building but still separate and one where they are connecting.



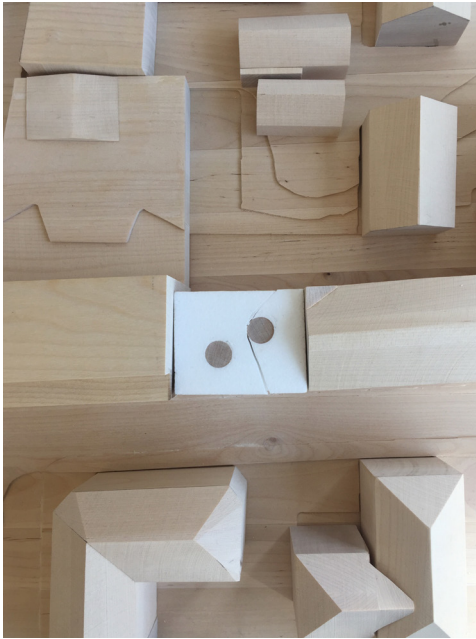



Photography has the chance of being damaged if it is exposed to too much direct sunlight. In a gallery, one has to be careful about this. If one wants natural lighting in the gallery rooms, some filtration of the light is necessary



Light entering the room through elevated boxes. The light enters through the sides of the boxes.



A second wall with its back to the window and the light.



A filtrated skylight. The element elevated from the ceiling has two curved sides that transforms the light into the room.



A low window opening gives natural light that hits only the lower part of the room.



A room with oval walls. The wall with the photograph is pulled out from the rest, creating an opening behind it. The light flows on to the curving walls.



Combining the load bearing columns and the transportation of light through the levels of the building.



A general lighting provided through the ceiling. The glass is frosted, evening out the light.

DIRECTED SEQUENCES OF ROOMS

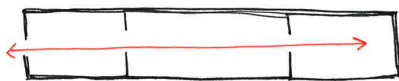
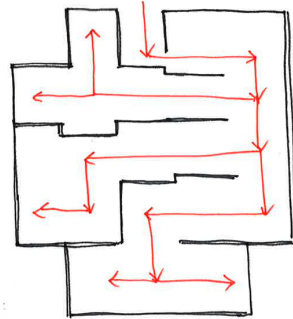
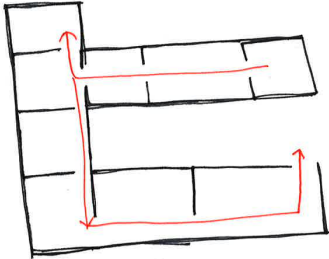
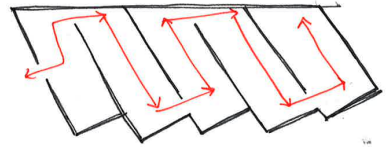
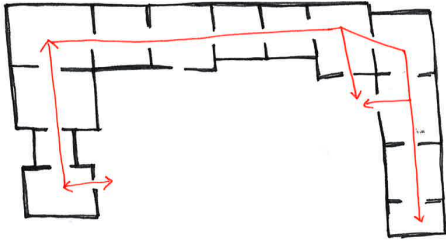

*Directed sequences of rooms
Connecting rooms along a single axis*

DIRECTED SEQUENCES OF ROOMS

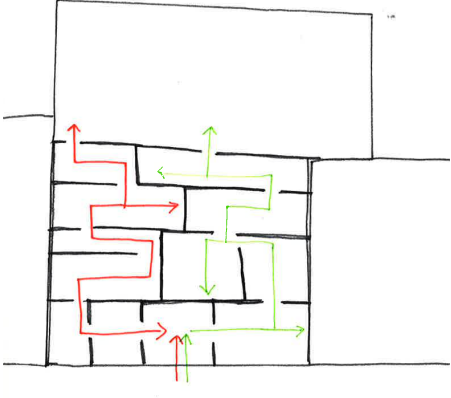
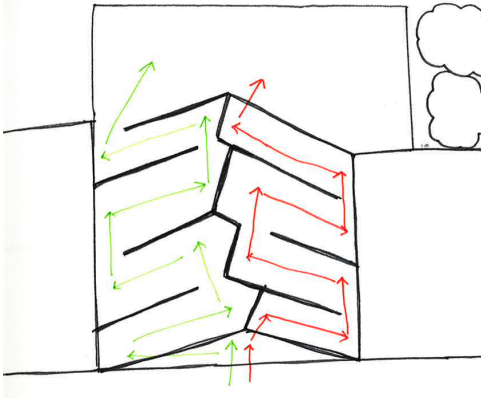

MATRIX-LIKE ARRANGEMENTS OF ROOMS

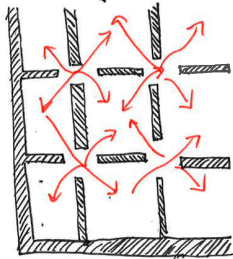
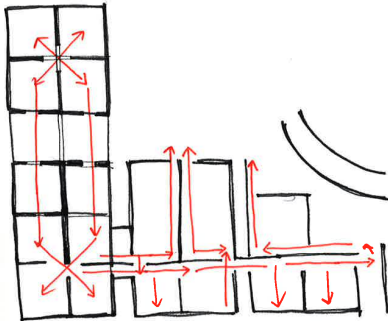
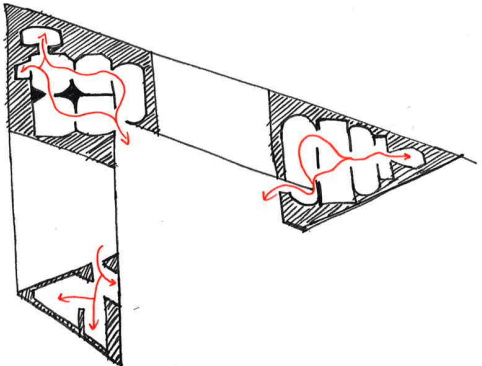
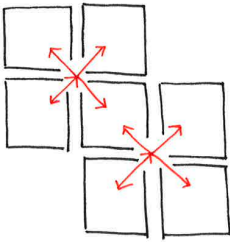

Matrix-like arrangement of rooms

MATRIX-LIKE ARRANGEMENTS OF ROOMS

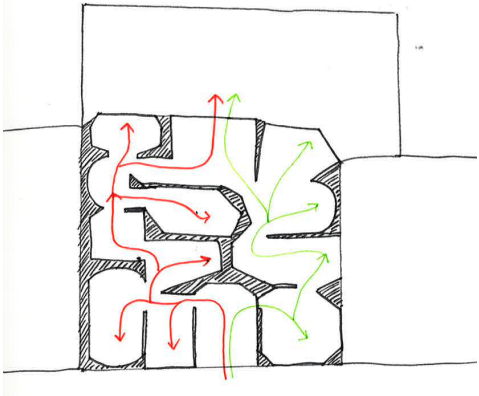
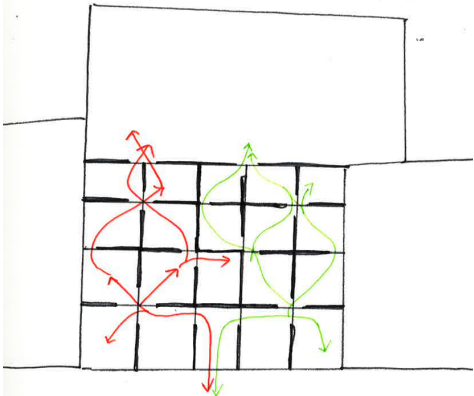

SPATIAL INTERPENETRATION AND
SPATIAL ISOLATION

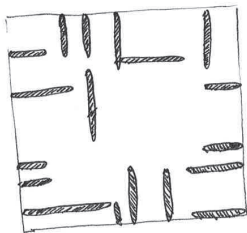
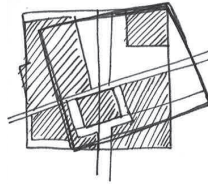
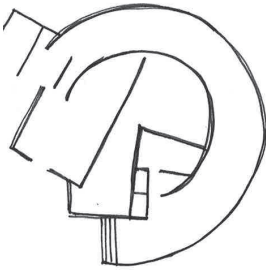

Kunsthalle Philip Johnson

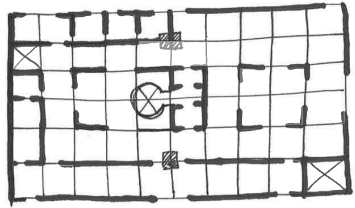

*Spatial interpenetration and spatial
isolation*

SPATIAL INTERPENETRATION AND
SPATIAL ISOLATION

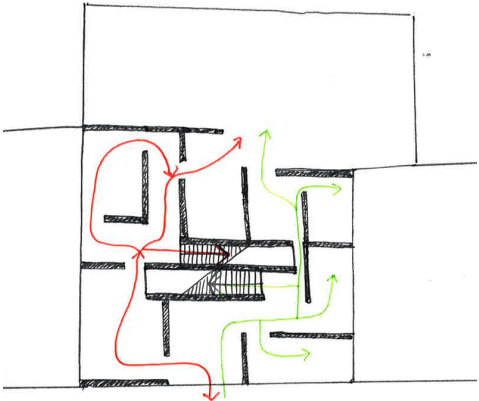
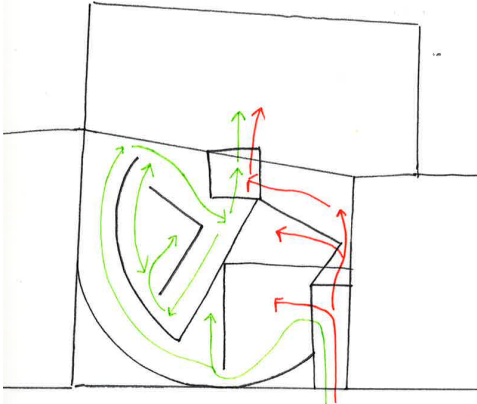

OPEN PLANS

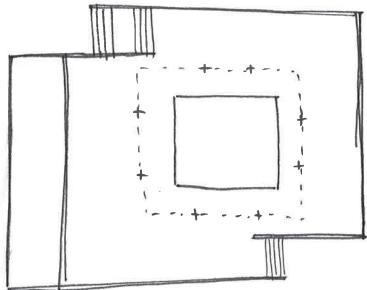
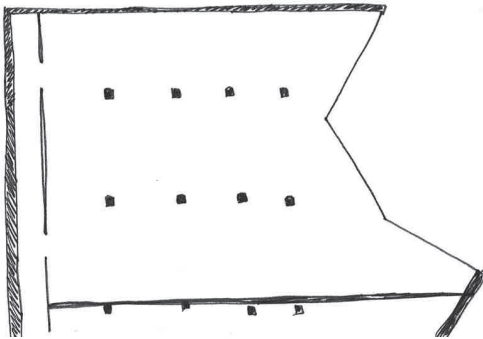
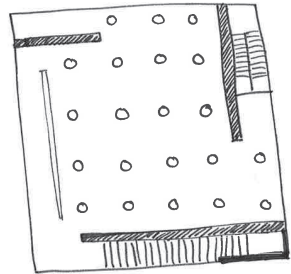
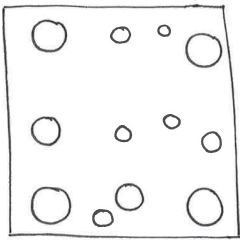

Open plans

OPEN PLANS

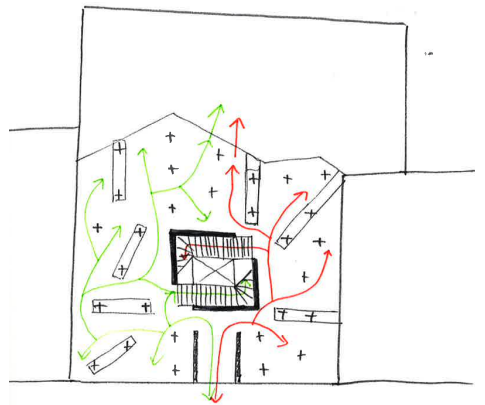
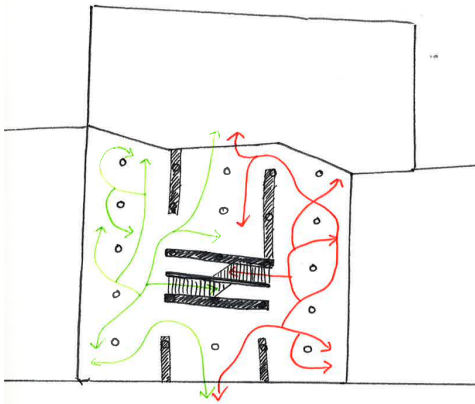

FREE FORM SPACES

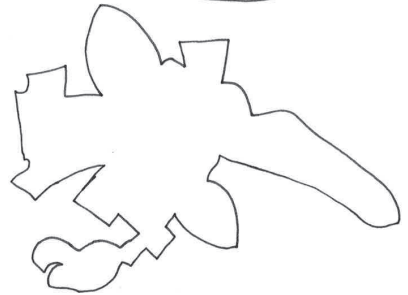
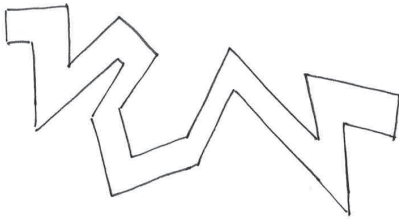
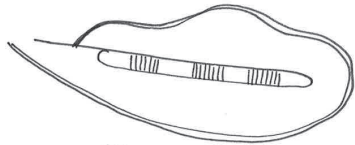
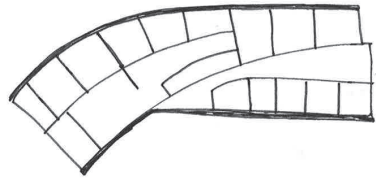
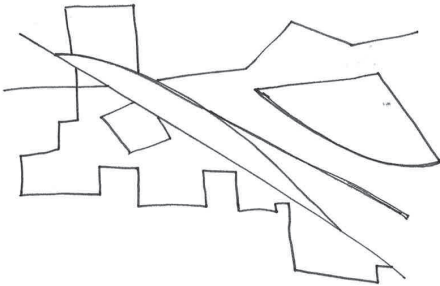

Free form spaces

FREE FORM SPACES

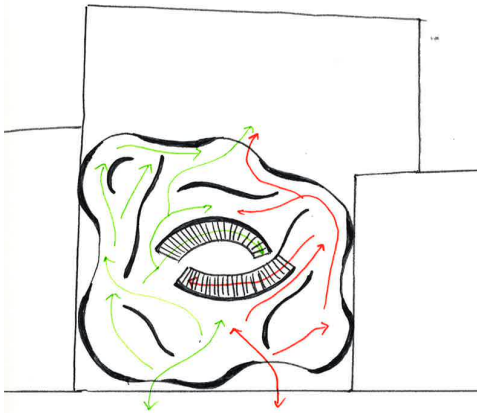
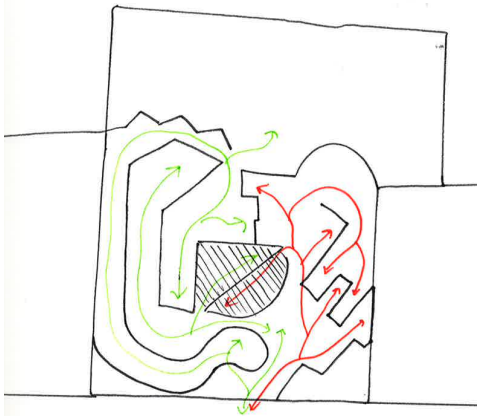

CONSTRUCTION STRATEGIES

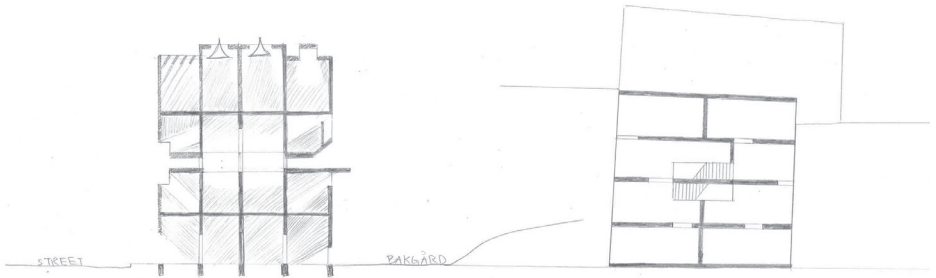

■ PHOTOGRAPHER
■ VISITOR



1

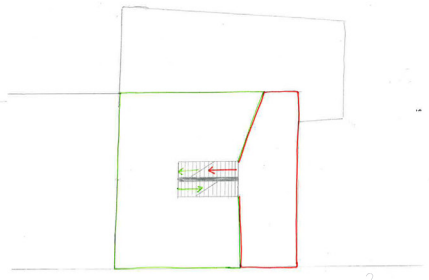

2

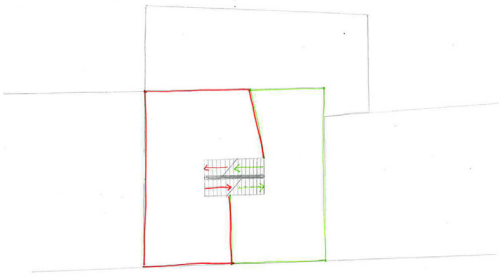

3

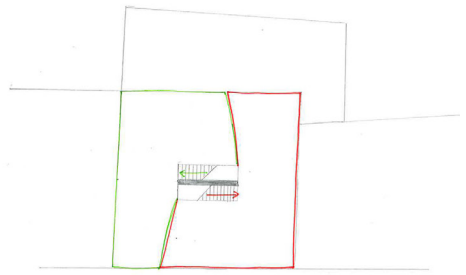

4

Photography makes something three dimensional into something two dimensional. By reversing the process through architecture, I use the two dimensional elements - frames, and create a three dimensional space

between them. The frames will open and close to allow light to enter the building.

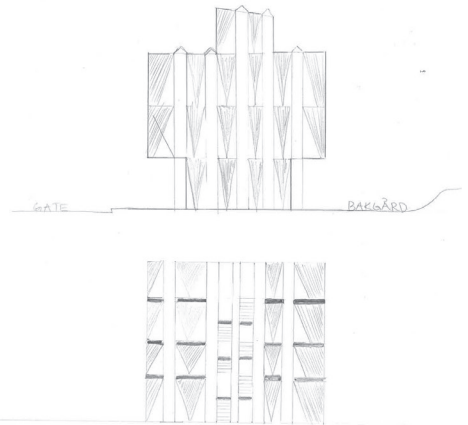
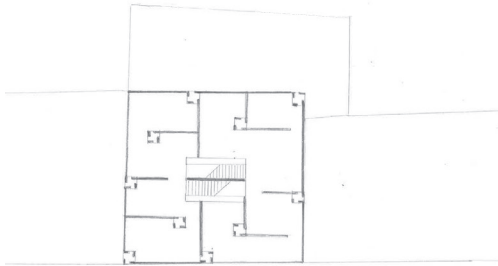
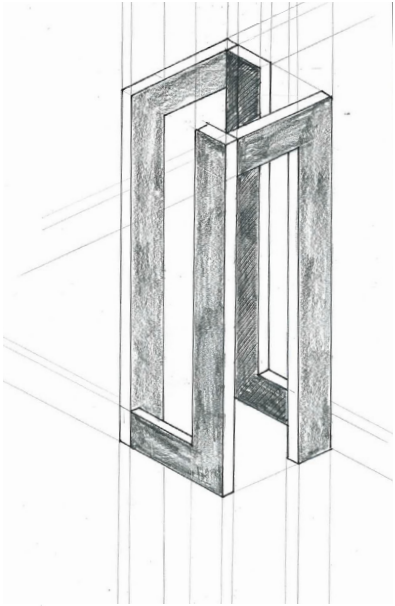

Combining construction and transportation of light, through columns/light wells. Functioning as the load bearing construction and the only source of natural light. The light intensity will vary down through the

floors, and the program will therefore adapt by their needs of light. The light wells will be in reflecting materials to be able to transport light.

STUDYING THE PHOTOGRAPHER



Mapping the photographers workspaces. Three different photo studios and workshops for both analogue and digital works.

MARTHE EMILIE STRAMRUD

An artist/photographer, working in her own studio at Khio. Her photographs are mostly still life, taken in her studio. Only working with natural light entering through the four large windows on the south and west walls. Working with still life photography gives her the opportunity to use long exposure time and small aperture. This makes her less dependent on a large amount of light. Working with natural lighting is her preferred way, although it is less predictable, making her workday spontaneous.

She primarily uses analogue equipment, develop them at professionals, receives the negatives and cre-

ates her own copies at workshops at Khio. She does not develop her own photographs, since she takes colour photographs, which are much more difficult to develop than black and white photography.

In a new studio, she would want larger windows, transporting more light into the room, especially for non-still life photography. Rooms where the light easily can be controlled and adjusted, with blinds, shades and filters. Since she works as an artist and a photographer, she prefers to have her own permanent workstation.

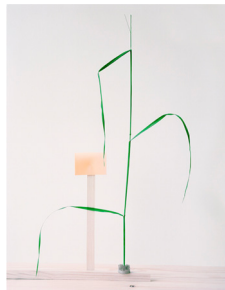

WLODEK WITEK

Working full time as a paper and photo conservator, Wlodek Witek proves to have a deep interest in experimenting with paper qualities and characteristics. His full time hobby is therefore an early photographic process called calotype, using large cameras and making his own negatives. The whole process can take a whole day, from capturing the scene through a shutter speed varying between 45 seconds and two hours to developing the fragile photo paper. Going through this complicated process, he has a success rate of 50%, making it a slow working method.

Capturing most of his photographs on his travels, he does not use studios much. He does however need a darkroom for developing his work and galleries to exhibit. In his opinion, a gallery wall should never be white, since it “steals” the light, but a shade of light grey is to be preferred.



SARA ANGELICA SPILLING

Self-employed photographer working as a part of Studio 110 at Ensjø along with five others. Everyone at the studio has their own equipment stored, but they share a workspace, a 5x5 studio and a kitchen. She works with a wide range of photography, both commercial and artistic. This means that she works in her own studio, larger rented studios and outdoor.

The studio is simple, yet flexible, with large windows to the southeast. If possible, she works with natural lighting entering through the windows that in the morning and early day, providing direct sunlight and defined shadows, and in the afternoon a more general and milder light. She primarily uses digital equipment but still prefers a dark space for the editing, to be able to edit in

despite of the days lighting conditions.

In a new studio, she would want a much larger room, preferably 10 meters wide. It should be angled to point north, to get the best possible light conditions. There should be skylights to get the most optimal natural lighting. A permanent cove would be interesting to use, with the possibility to cover it with sheets of different colors and shapes.

STUDYING THE PHOTOGRAPHER

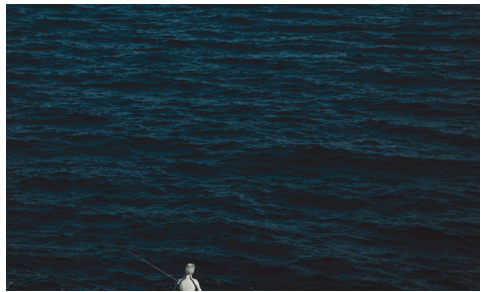
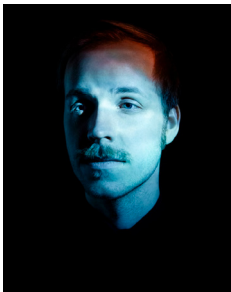

STIAN SCHIOLDBERG

Working part time as a photographer perusing his dream. He could no longer afford to keep a personal photo studio, but now rents studios or works on location for clients. Working primarily with art photography and portraits, for clients and for his own exhibitions. He has worked on many different locations chosen by the client, and is excited by the challenges they bring.

Working in the photo studio, he is most used to work with artificial light. Having large open spaces and a selection of equipment. He mostly prefers the digital photography, because of its flexibility and effectiveness, but sometimes use analogue for experiments. The home office is the preferred workspace, which is where he does the editing and some of the smaller-sized printing. The

larger print and aluminium prints are done professionally.

In a new studio, he would want a very large space, similarly to the ones he had before. A ceiling height of 3.5 to 4 meters and a width of 7 to 10 meters. The ceiling should contain a frame, to hold the lights, reflectors and other equipment to be easily adjusted. A north-angled window or a ceiling light, providing an even light of the room, is preferred while working with natural lighting.



STUDIO DAG ALVENG

Not being able to meet with the actual photographer, as he is on one of his trips, I got an interview with one of his assistants and a tour of the studio. Being one of the more famous photographers, Dag Alveng has three assistants working full time for him producing the prints of the work while he is out traveling and taking pictures.

Dag works exclusively with analogue photography and with large negatives. The negatives are stored in shelves at the studio along with master prints and equipment. The work is developed in a darkroom at the studio, where it can be printed in a certain size. For the production of exhibition prints, he has a barn in Asker with a large printer. As he is a photographer “on his way”, he takes

most of his pictures spontaneously, and after a while, he finds that something can turn into a photo series.

Taking most of his photos on his way, he uses indoor studios quite rarely. But when he does, it is all about spontaneity and flexibility. Having the possibility to choose between a studio facing a large window being able to use natural lighting or pulling the blinds and having a set of lights and reflectors to move around the room as he pleases.

STUDYING THE PHOTOGRAPHER



By talking with the different photographers, I gained more knowledge and information about what a photo studio should be and what is necessary for it to be a success. In conclusion, I have learnt that photographers have very different working methods, but can agree on some things when it comes to the indoor photo studios.

One of the things that caught my attention was the interest for photo studios with natural lighting. Most of all, the repeated wish for a large north-angled photo studio. I wish to take this very specific and crucial discovery with me into the project.

The topic of skylight is also very well spoken of by the different photographers, which is something that will be worked with further in the project.

The shape of the cove, the rounded off edges that is used in almost eve-

ry photo studio, will be used both as a tool in the studios, but also as a symbol for the visitor to recognize. Seeing the back of this shape will inform them that what they are looking at is a place for the creation of photography, without them disturbing the work going on inside them.

Studios of total light isolation can be very useful for those who wish to only use artificial lighting. These can be combined with some adjustable solutions for light openings.

Rooms angled to the east-south-west side of the building are not preferred and can be more difficult to use for some photographers, although some actually prefer them, especially for still life photography. I will therefore include some smaller studios with this quality.

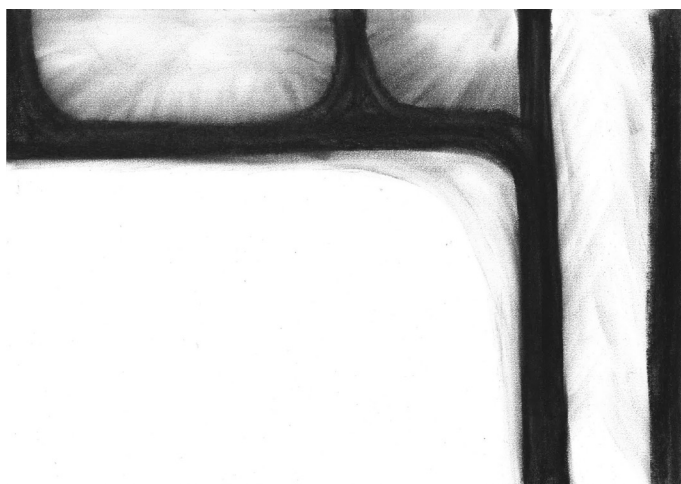
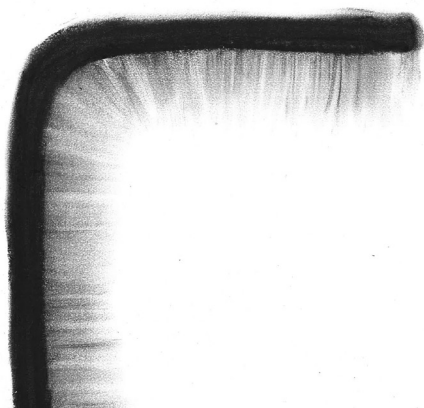
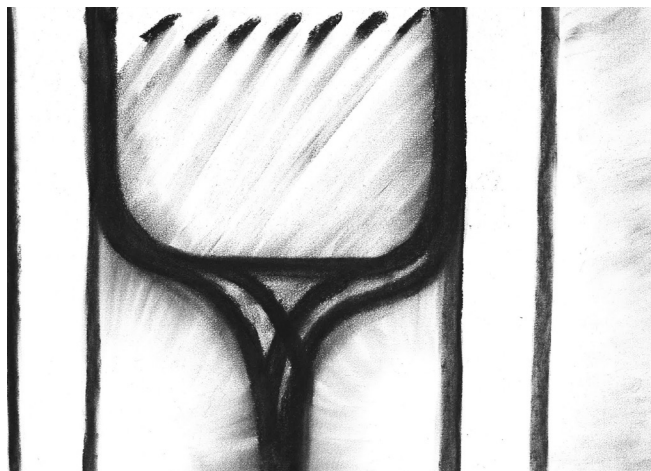

GRADIENT OF LIGHT



	Photo studio	
Exhibition space	Digital workspace	Exhibition space
Exhibition space shop	Meeting-rooms	Cafe Bar
Exhibition space	Darkroom	Exhibition space

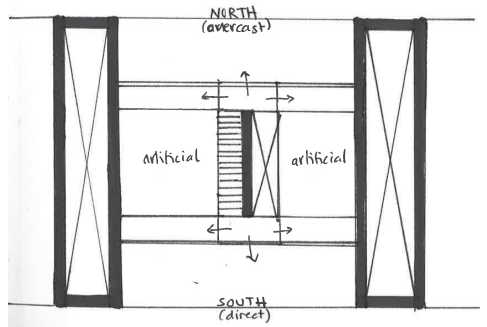
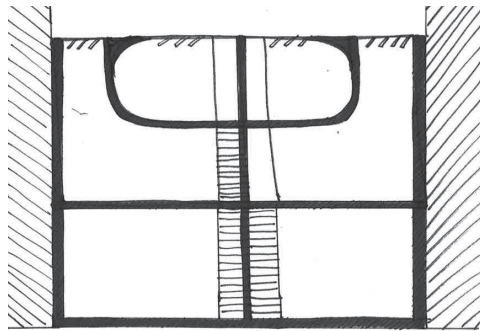

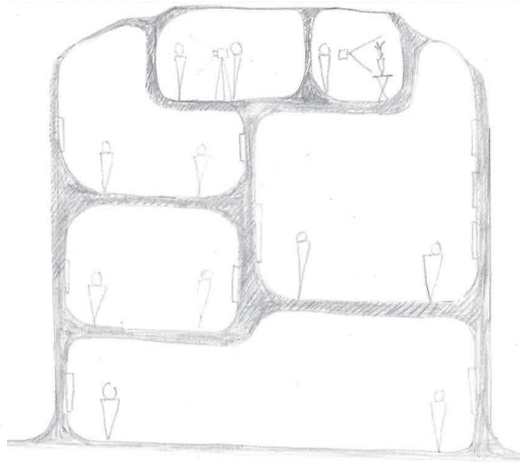
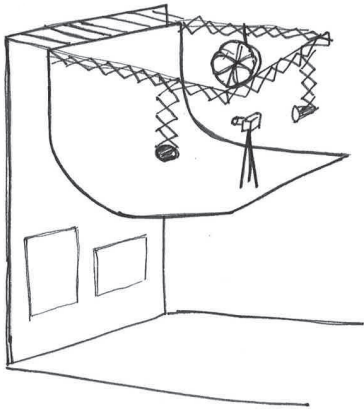

NO CORNERS

- creating a distance between the photograph and the visitor
- erasing corners and the meetingpoints of walls, floors and ceilings

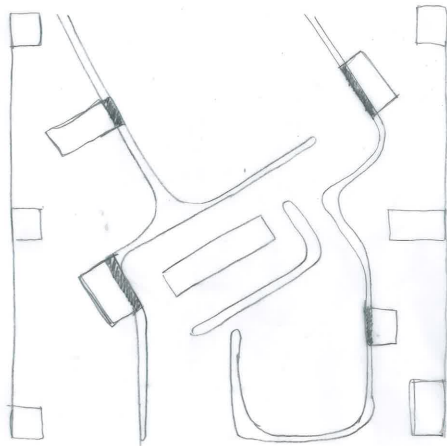
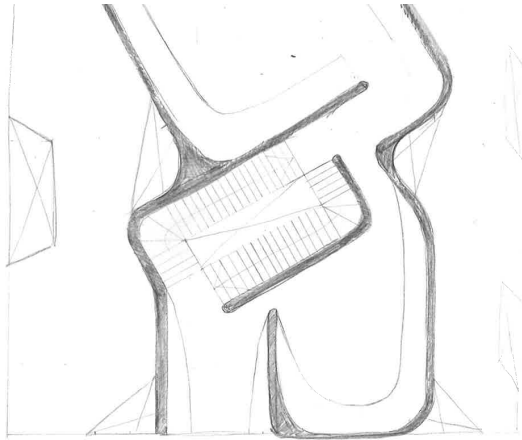
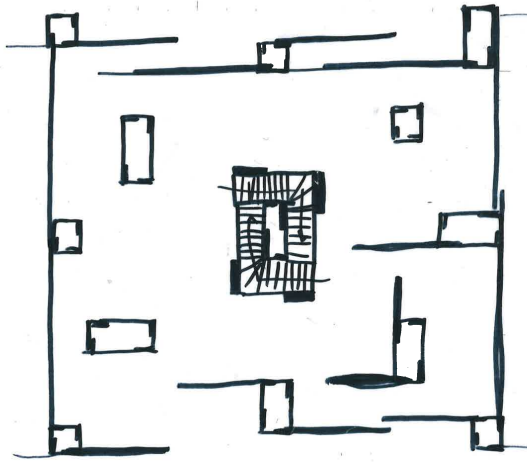

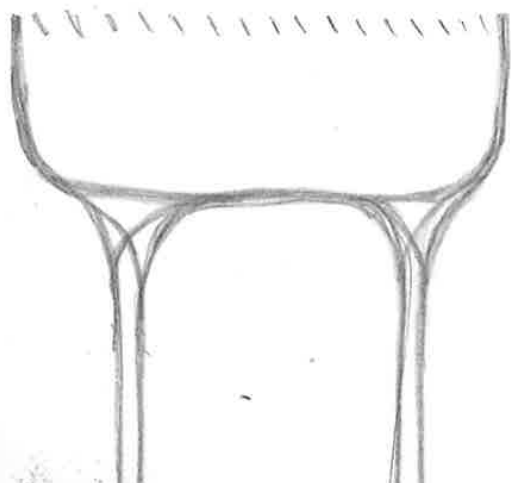
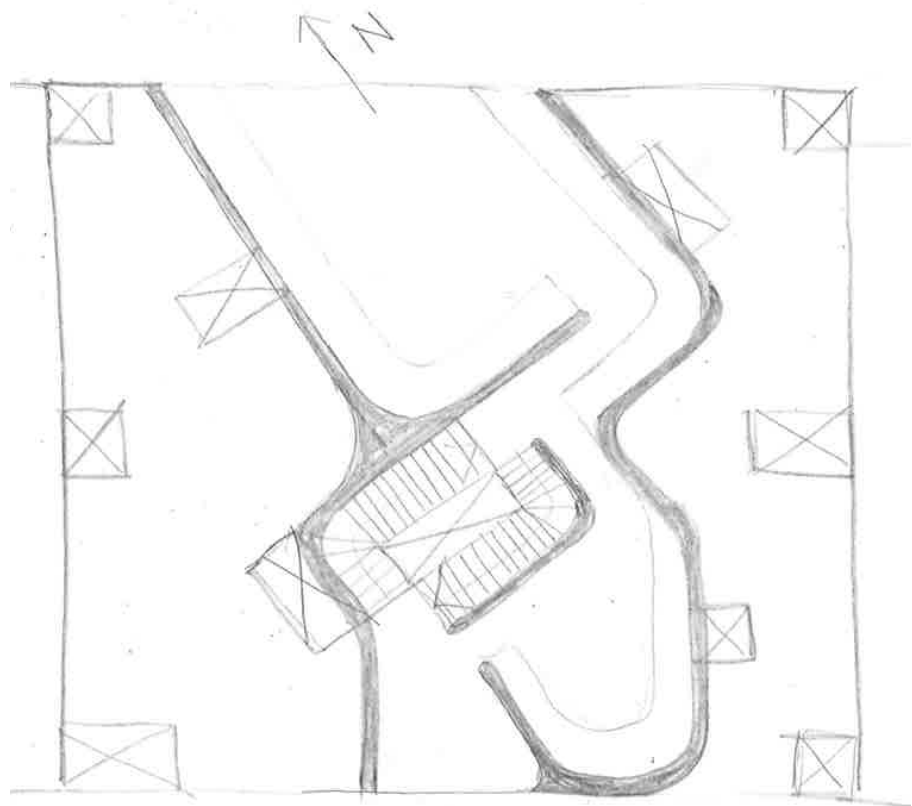

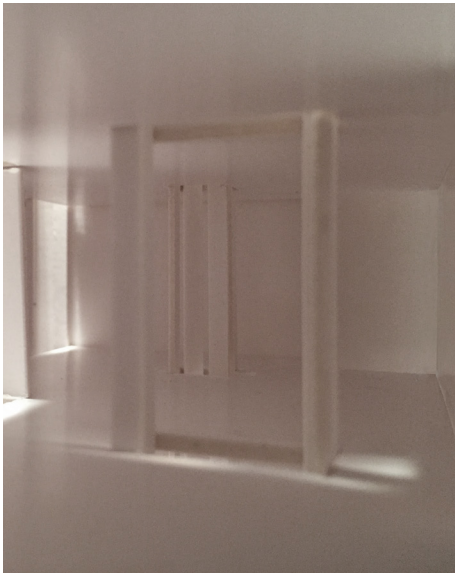

In a 1:100 model, I have tested the light wells drawn in the sketches. The wells vary in size from 1-2 meters long. The light varies quite a lot from the top to the bottom floor as

suspected. The light decreases and can be barely absent in the very last floor. In the two upper floors the light is very much present, and can be used as a light source at daytime.

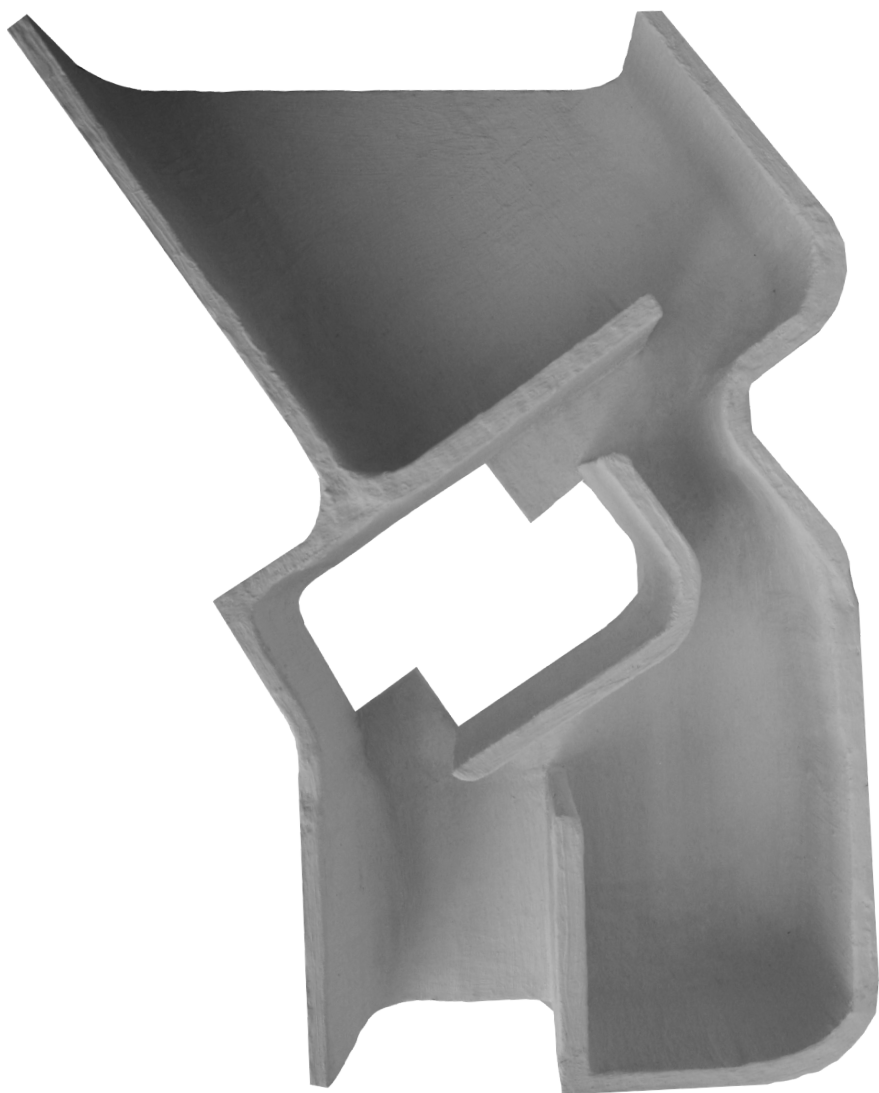

Model of photo studio spaces - 1:25



Photo studio facing the south-west. The open facade gives the studio the possibility to use direct sunlight, with creates harder shadows.



Photo studio without windows to the facade. The diffuse skylight provided with natural lighting gives a good start for an artificially lit photo-shoot.



Photo studio facing directly north. This gives the studio the advantage of always having a steady neutral natural light during the day, never having to tackle the hard shadows of the direct sun. The ceiling gives

a filtrated natural light, which is preferred in this kind of studio.

ELEVEN AND TWELVE

Taking this concept further, I made a model in 1:50, containing spaces created by the shape of the photo studio. The shapes are made solid in this model, but every wall is not necessarily closed, and can vary in the same way that the first three studio spaces were made. The spaces on the outside of the shapes are more open and flexible.

Although they are created for each part of the program, the spaces can in my opinion, both be used for the creation and the display of photography, making the building and the rooms more flexible.

PLAN SKETCHES

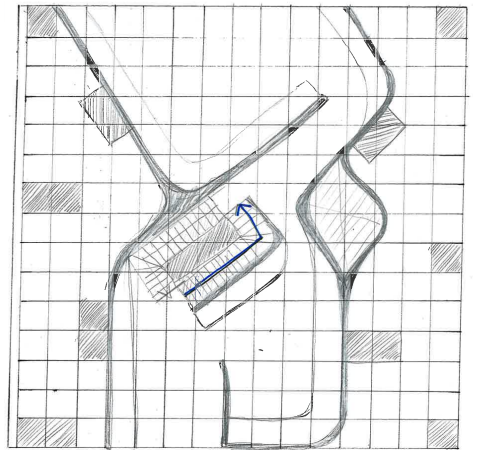
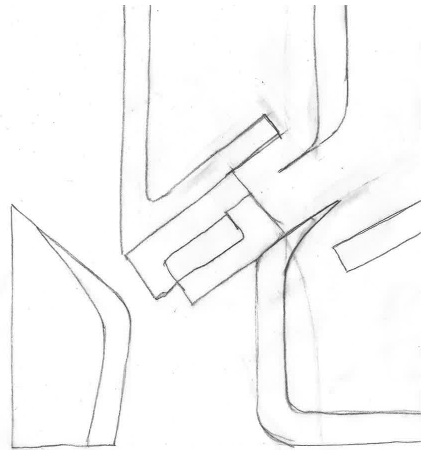
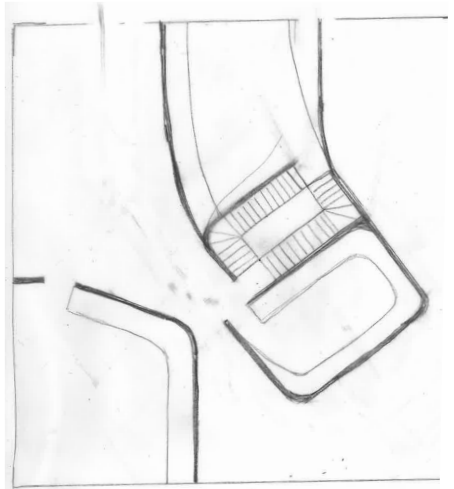
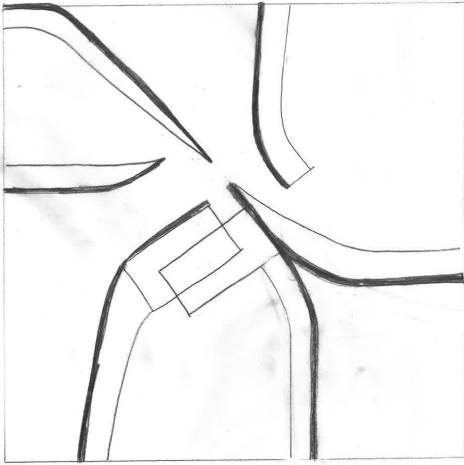

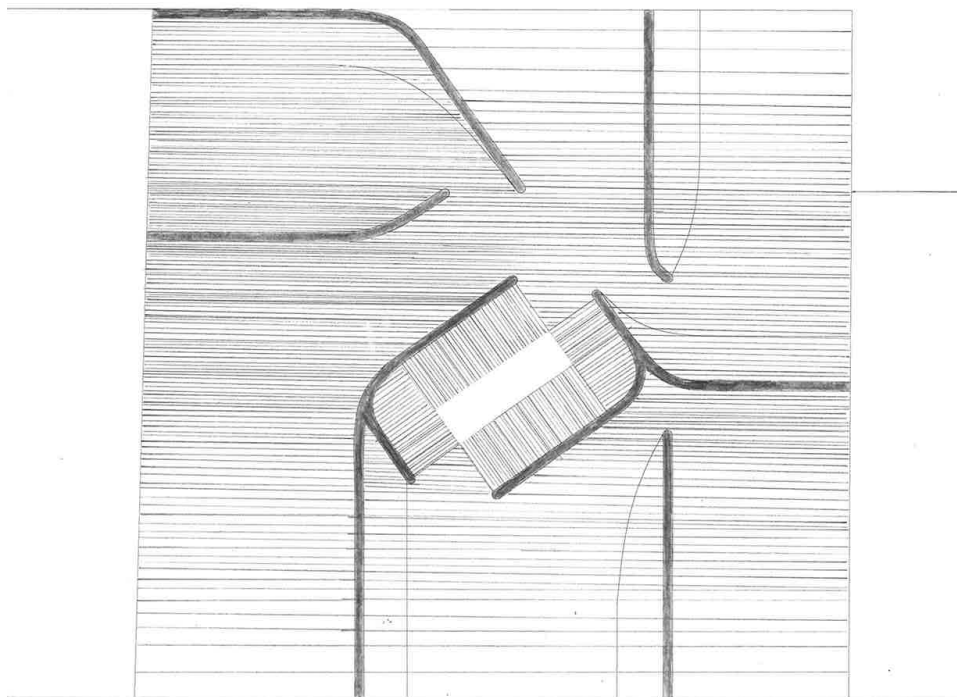

1

Plan drawings for the four floors. The plans are a representation of the 1:50 model. The vertical circulation is in a core, feeding into all the rooms at the different floors.

The plans and sections are illustrations of the natural light of the various rooms.

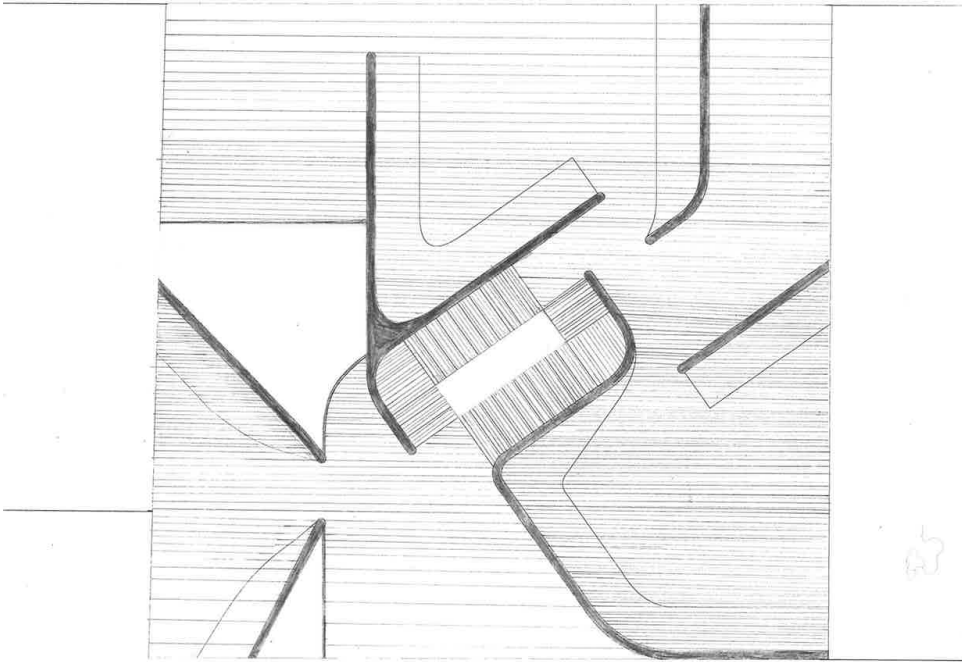

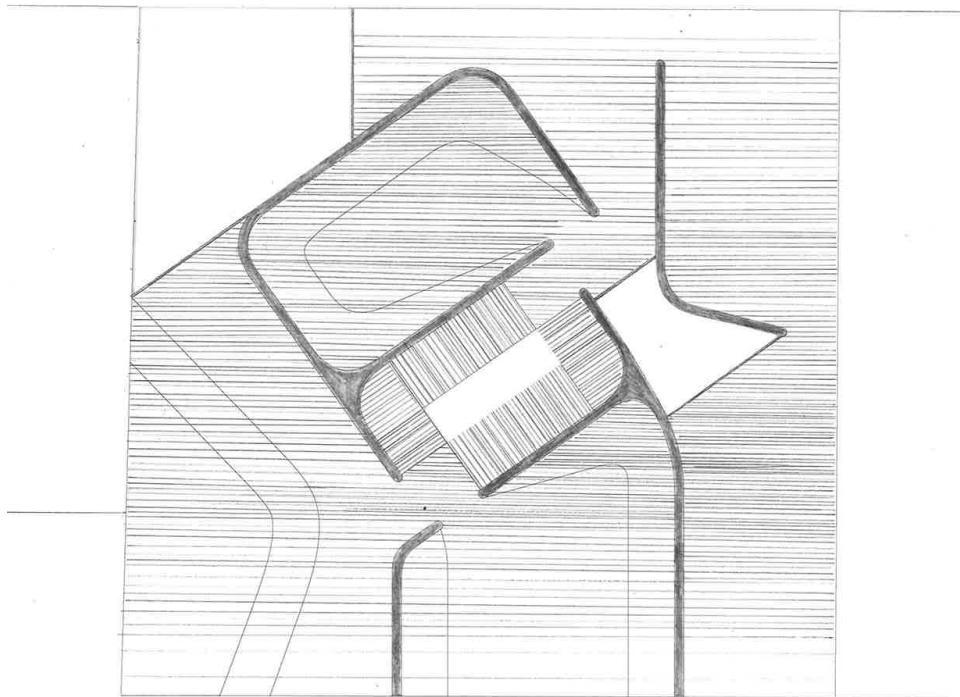

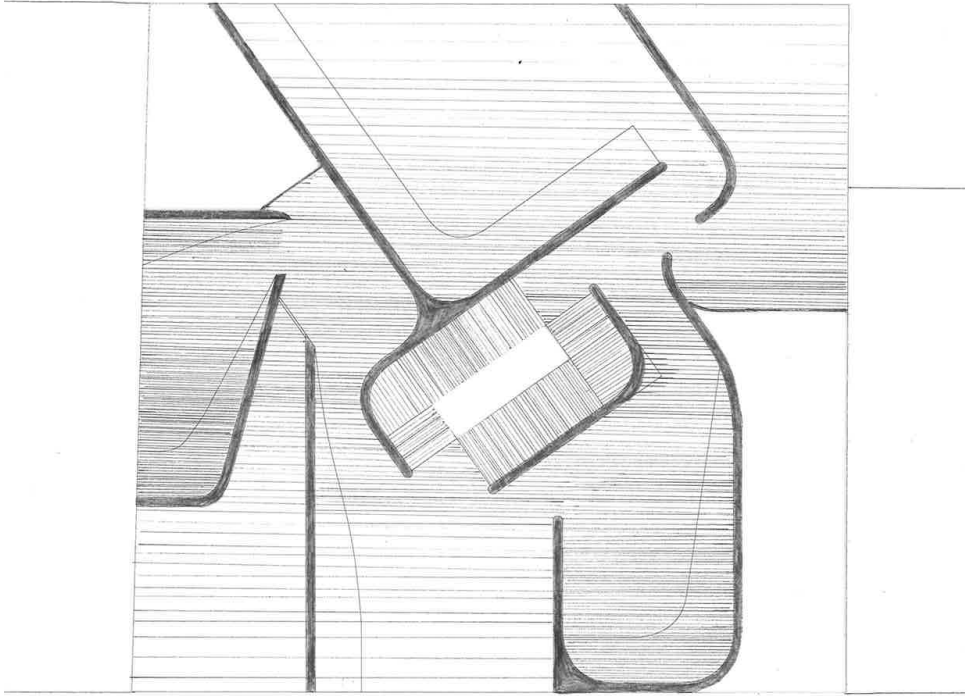

SECTION A

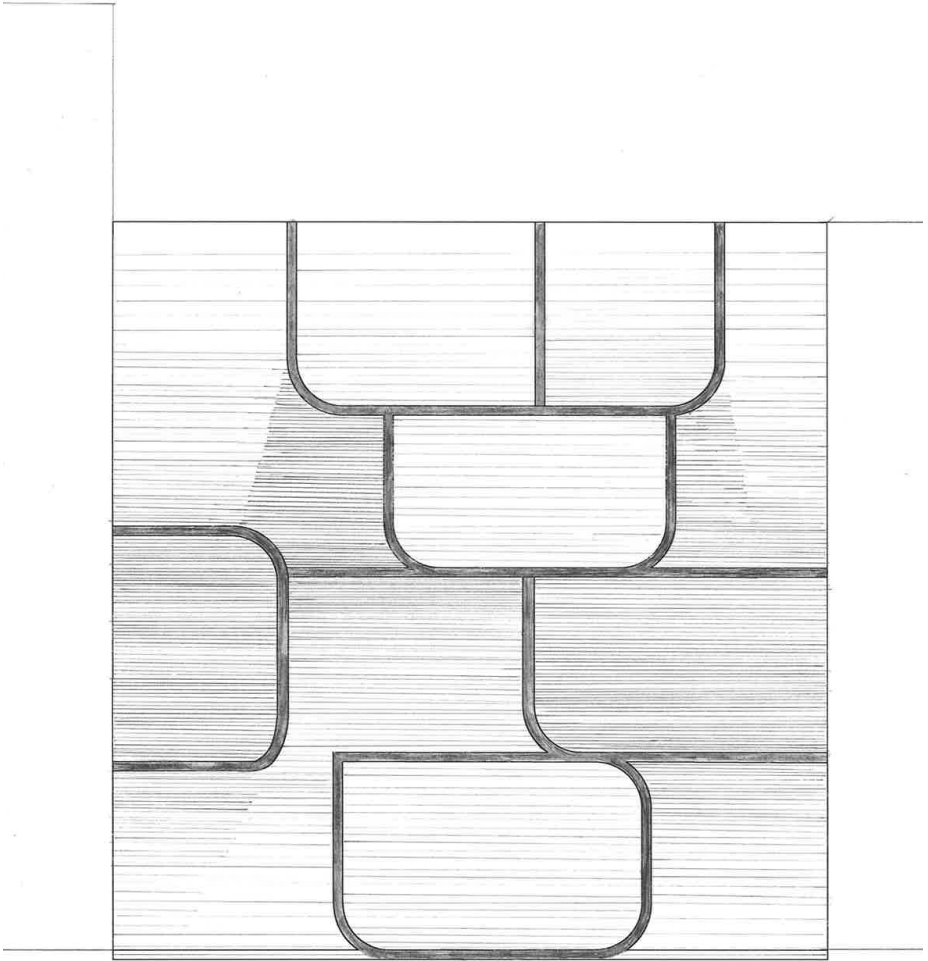

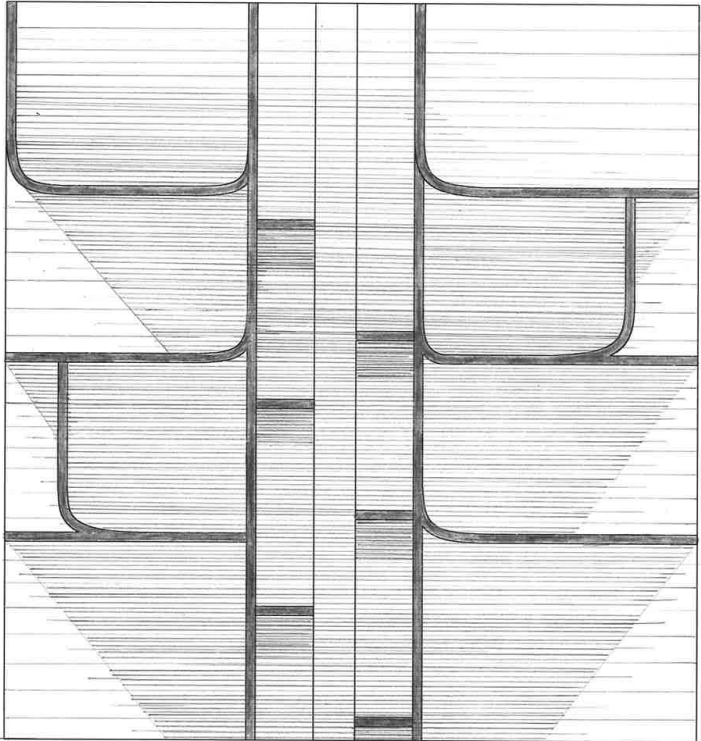

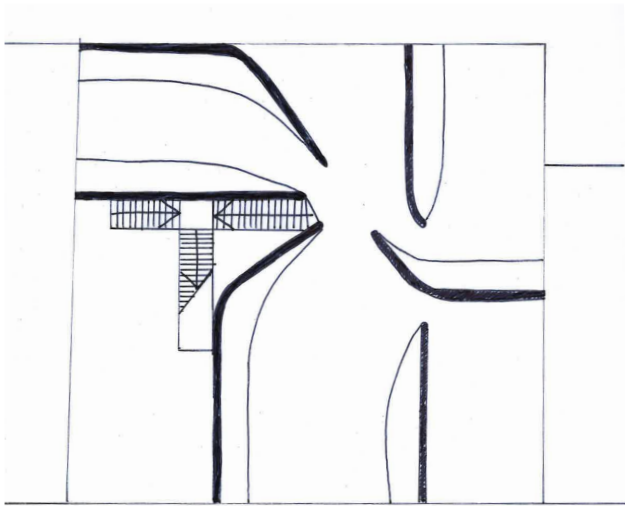

1

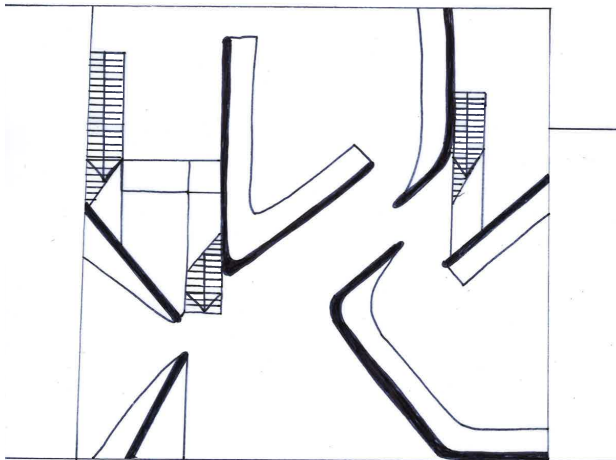

2

Trying out another way of solving the vertical communication of the building. The staircases are located in the “negative” spaces, where the floors open up and create double

heights. The stairs are therefore in different places for every floor, making you move horizontally in addition to vertically.

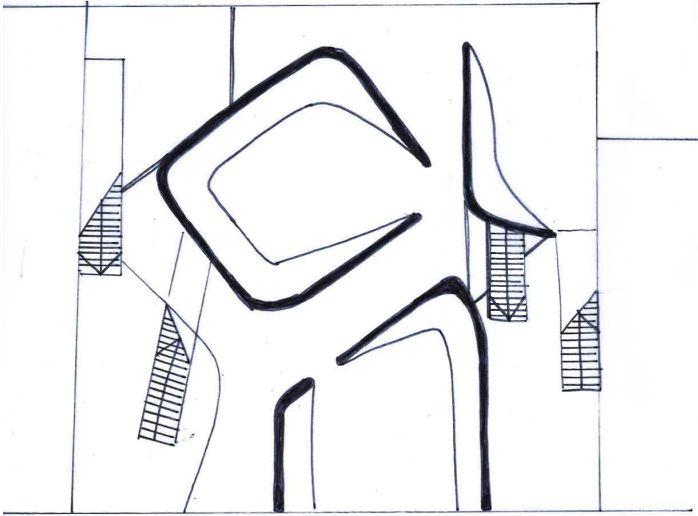

3

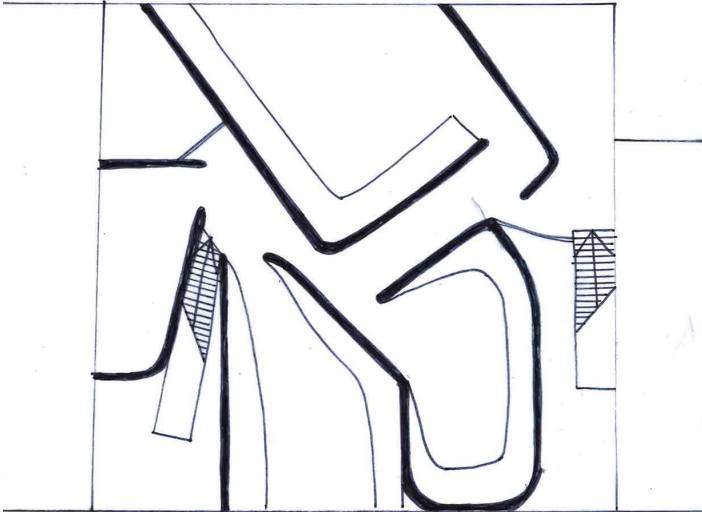

4

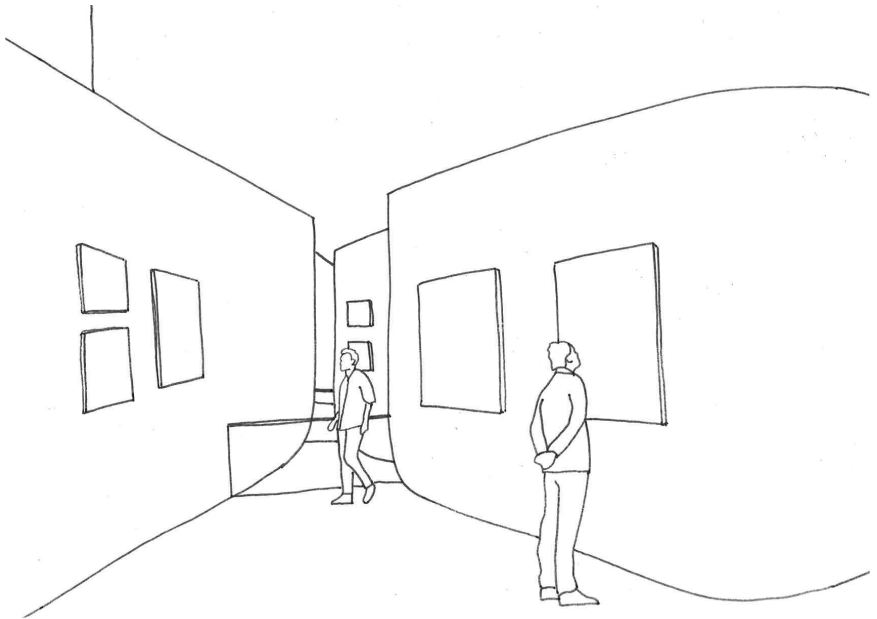
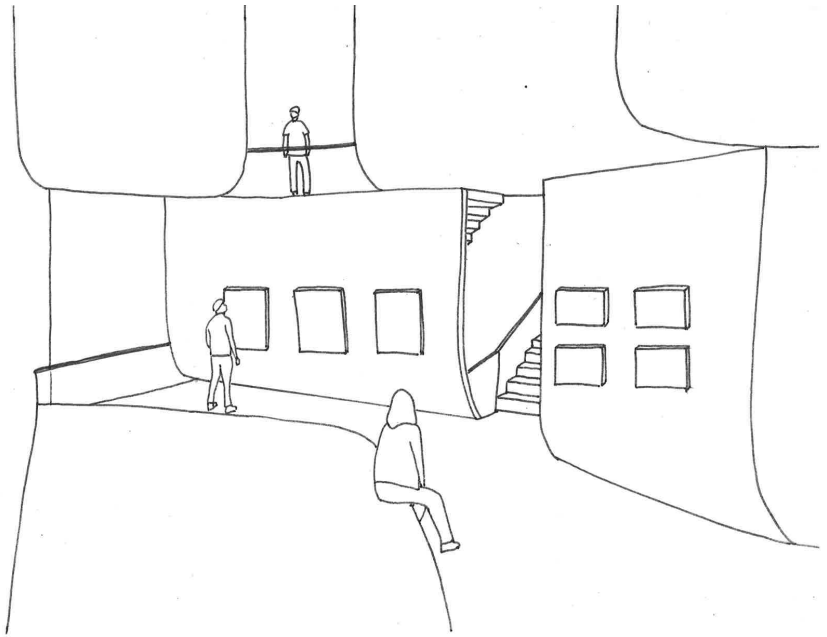

Sketch-illustrations based on the 1:50 model model

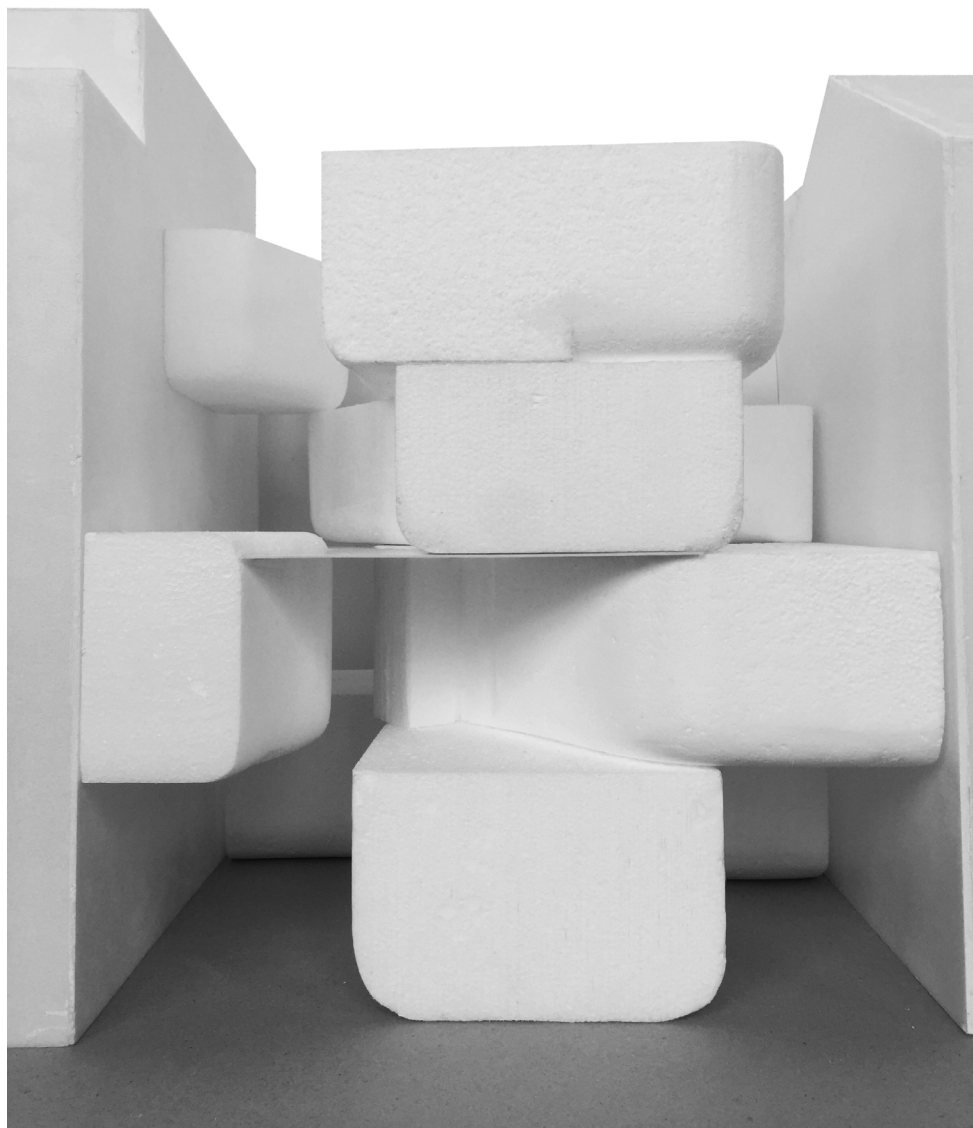

Model 1:50

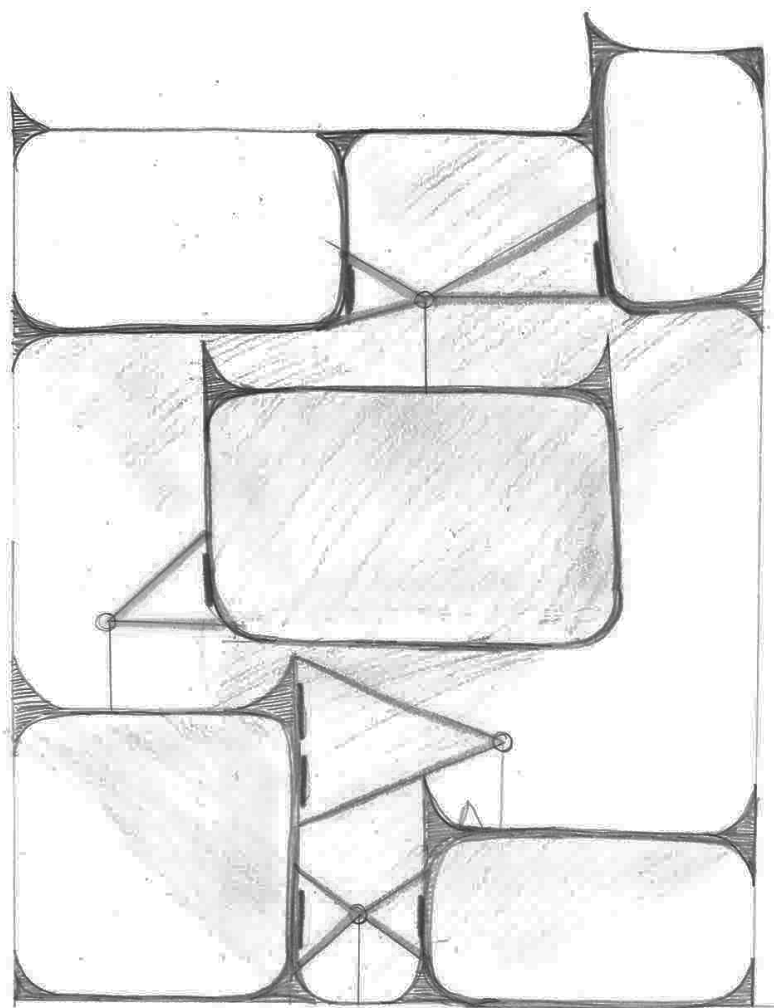

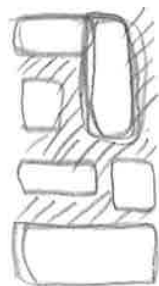
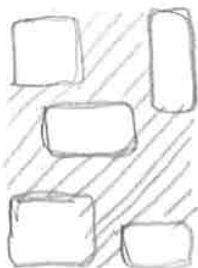
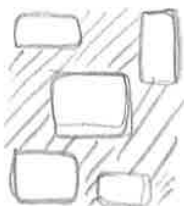
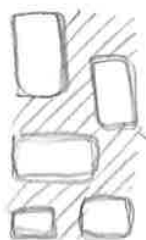
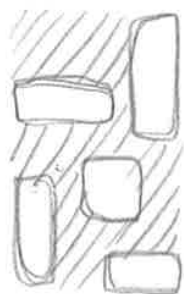
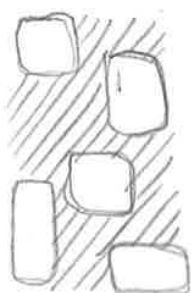
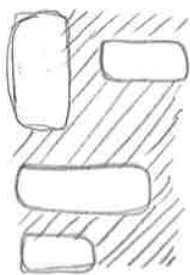
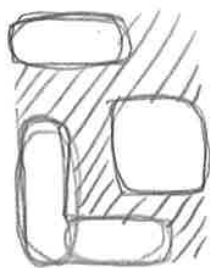

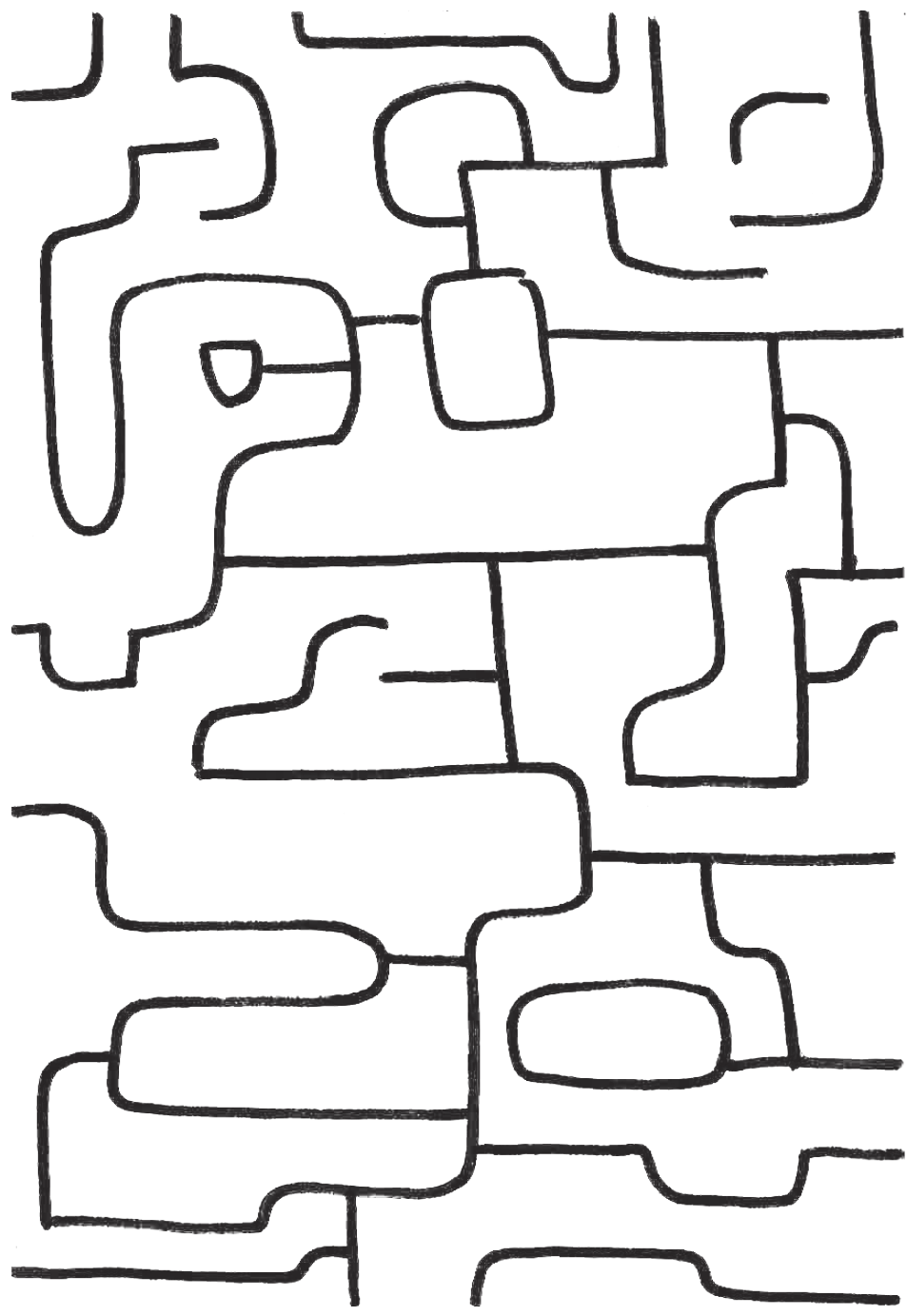

THIRTEEN AND FOURTEEN

Taking a step back, I find that there are some parts of the project that has been lost on the way. Some for the better and some not. One of the things I wish to bring back into the project is the two separate vertical communications - one for the photographer and one for the visitor. They can be physically separated but not necessarily visually. The spaces that are not gallery or photo studio spaces have also been out of focus the past weeks.

The construction system also has to be back in the focus, having an impact on the further development of the project.

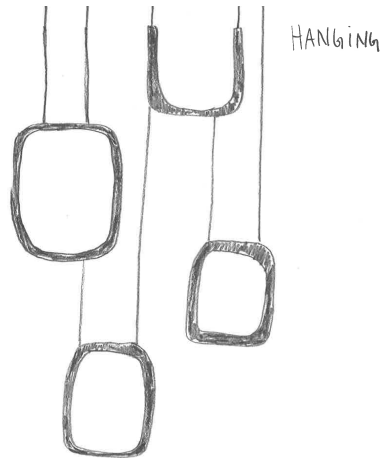
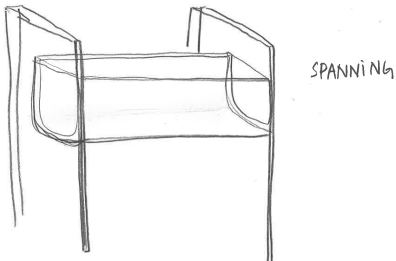
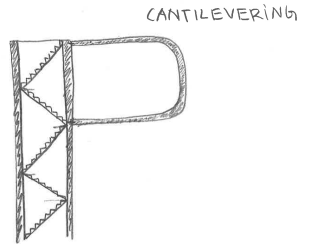
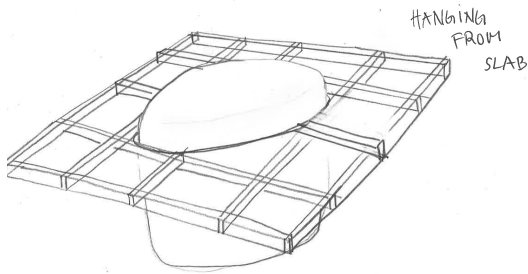
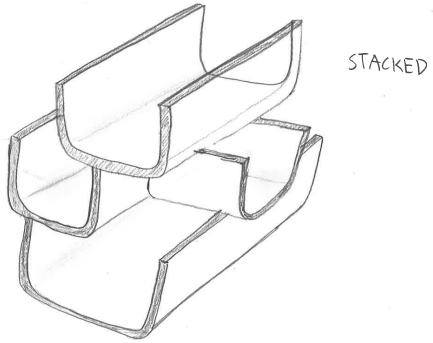
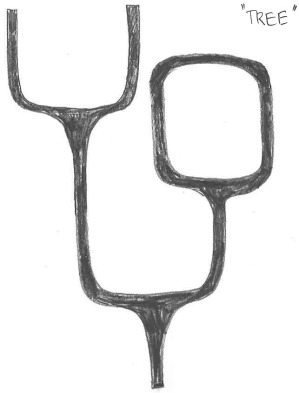

Testing out various construction methods and concepts. How can the photo studios be supported? Are they doing it themselves or is there a secondary construction.

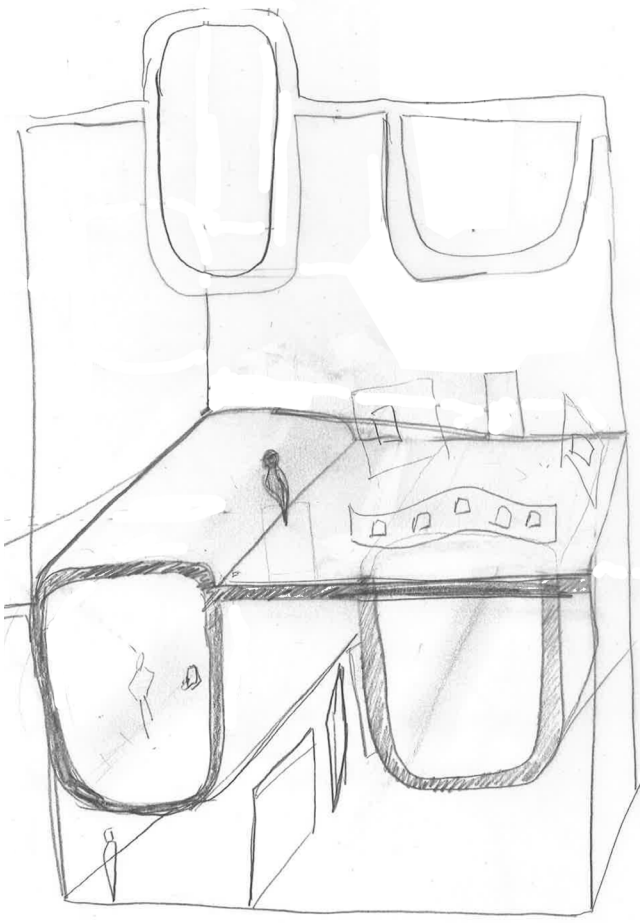
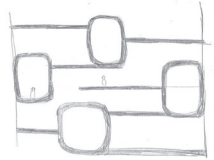

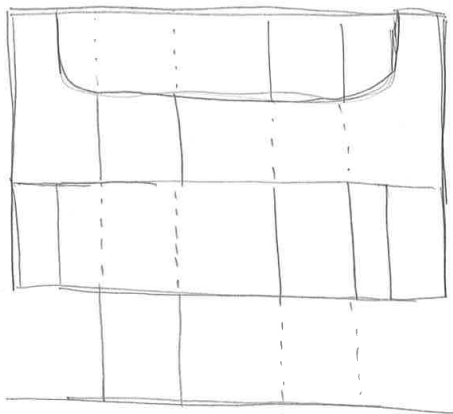
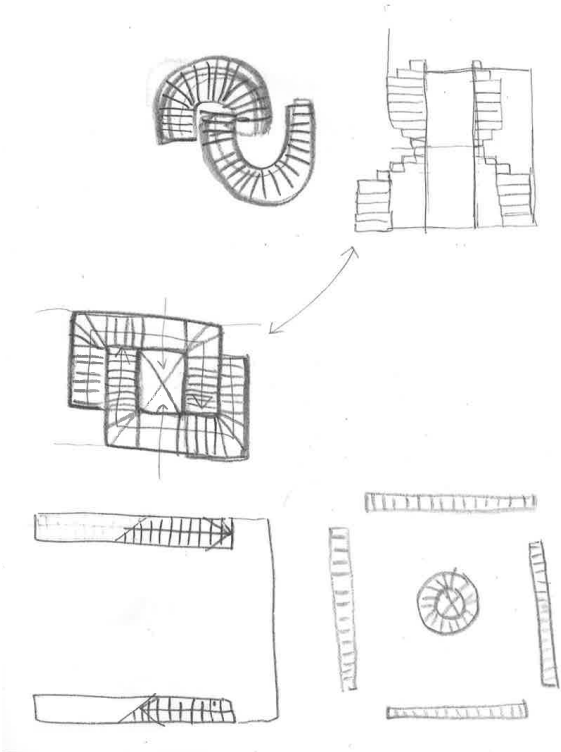

Produktespan

Utsikling

Produktespan

Utsikling

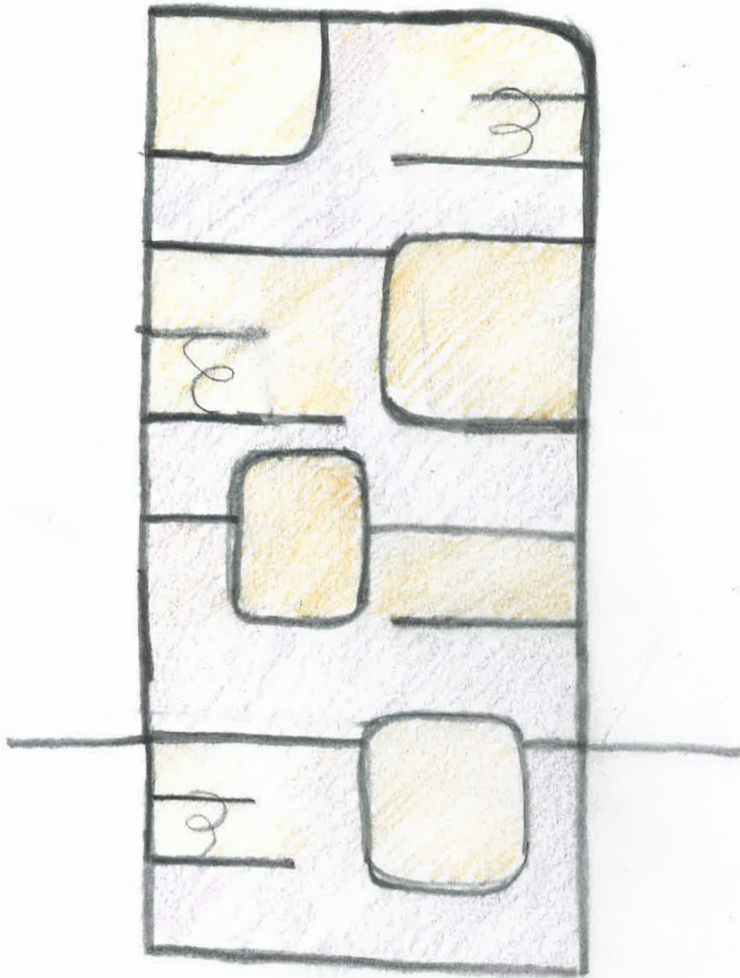

The separation of the two main programs - The display and the creation. The display is happening in the main floors, three above ground and one beneath. The creation is happening

in the “mezzanine” floors that are floating between and perforation the floors.

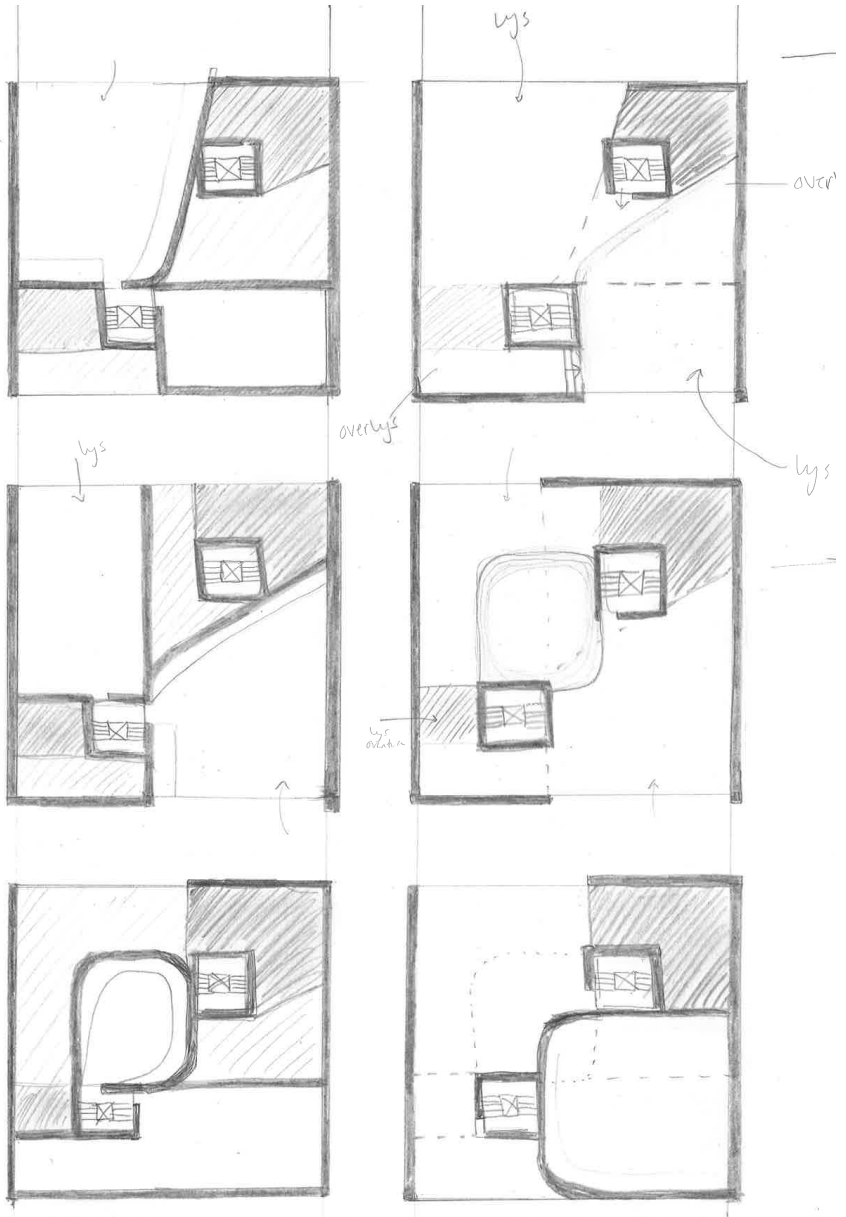

An attempt on making the mezzanine floors (to the right) and the main floors (to the left). Here with two separate vertical communication towers.

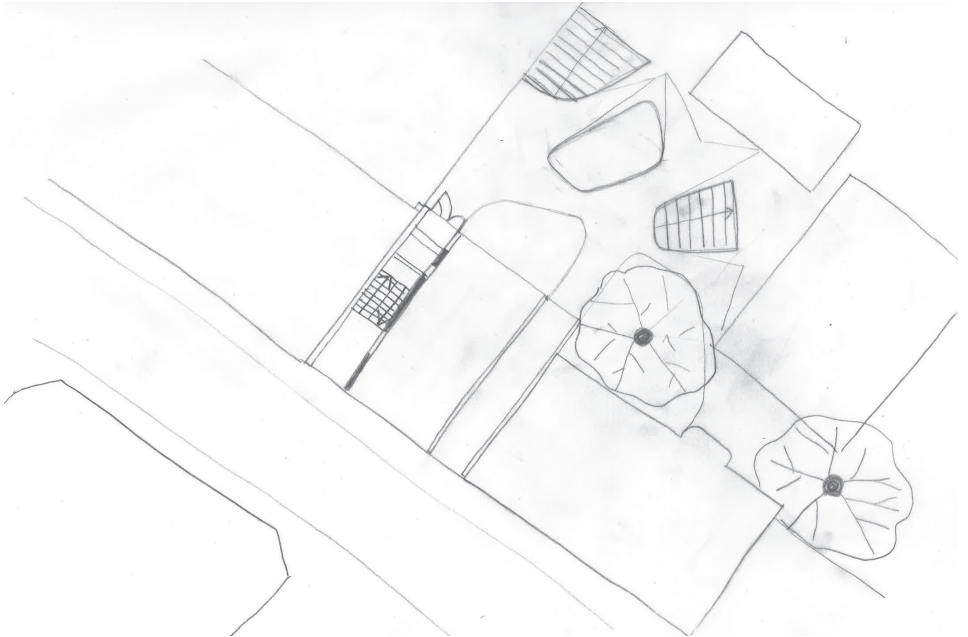
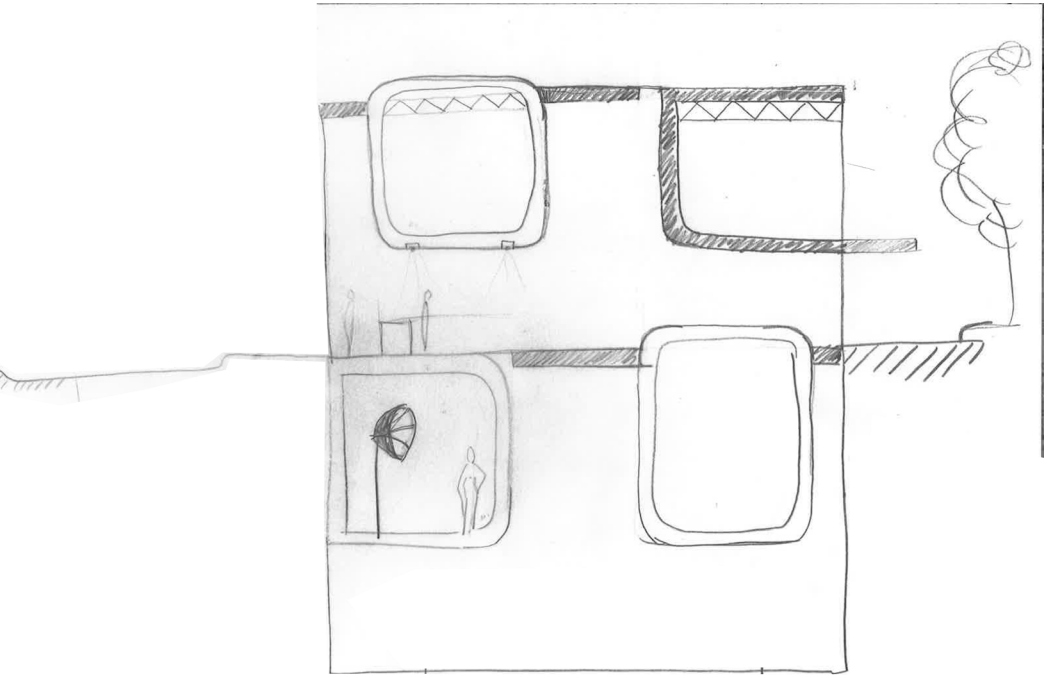

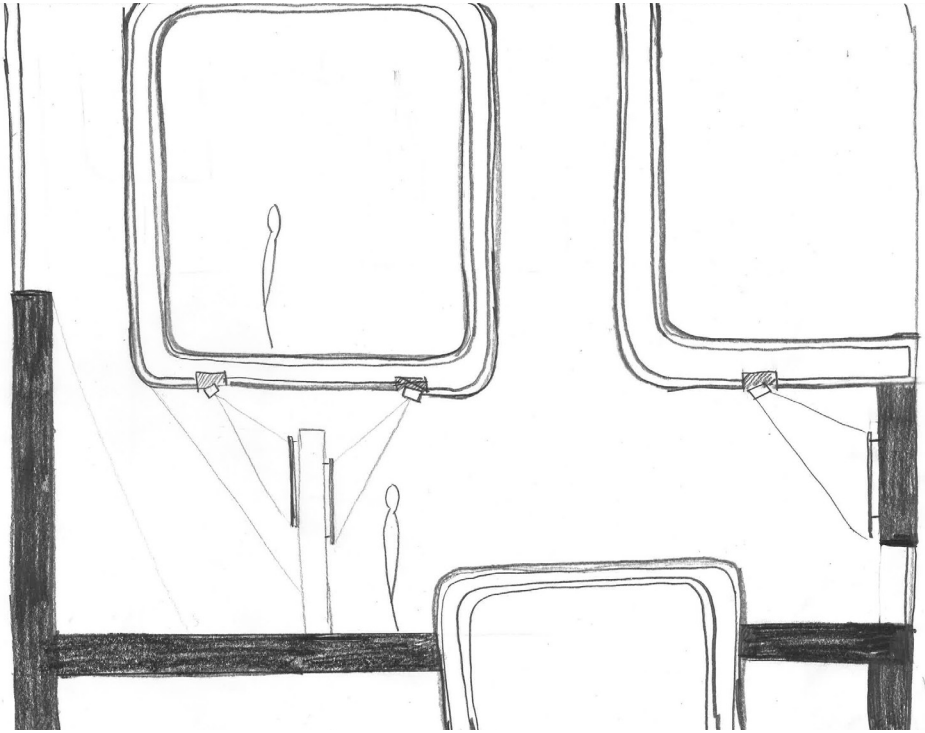

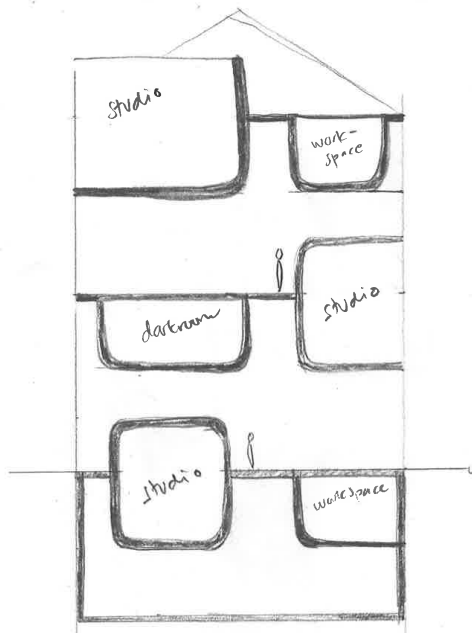

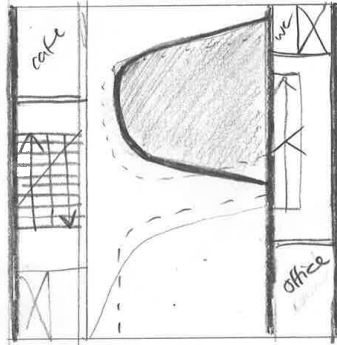
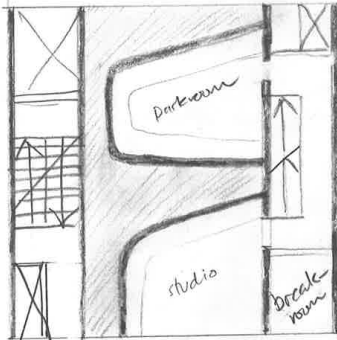
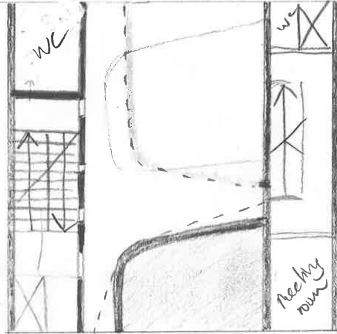
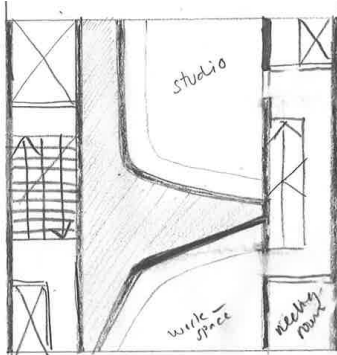

Ground floor

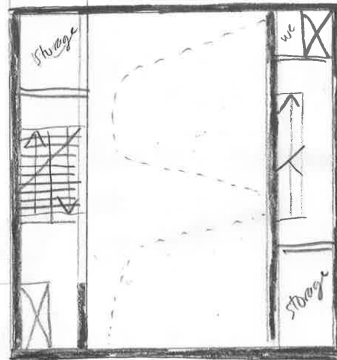
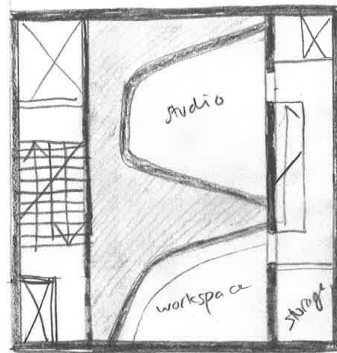

**Temporary
Exhibition
strategies**

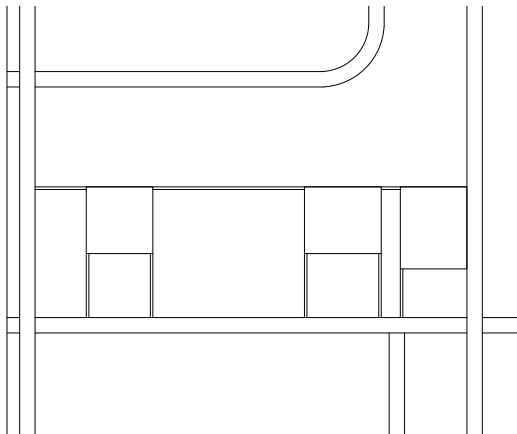

*Steel
systems*

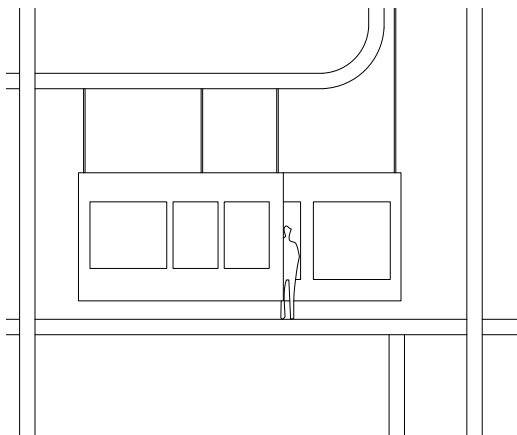

*Hanging
walls*

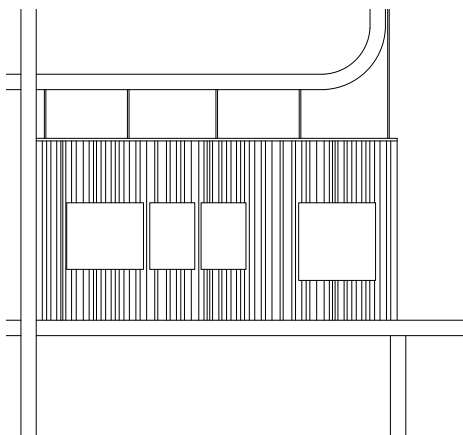

*Curtain/
drapes*

Neue Nationalgalerie, Berlin
Artist: Heinrich Ehmsen
Estate / SMB / Roman März



Neue Nationalgalerie, Berlin
Artist: Piet Mondrian



Neue Nationalgalerie, Berlin
Photographer:
Thomas Demand



FIFTEEN AND SIXTEEN



*Testing various flexible exhibitions in
a 1:25 interior model*





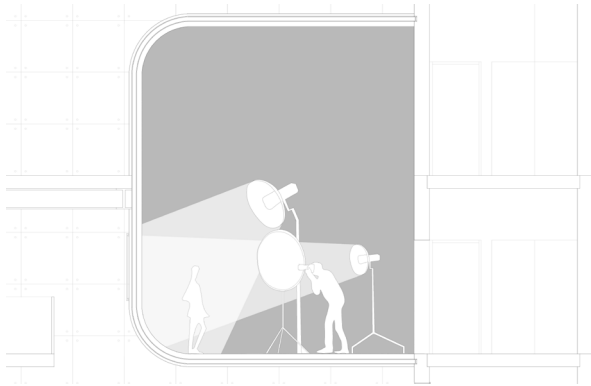

*Photo studio only with
artificial light*

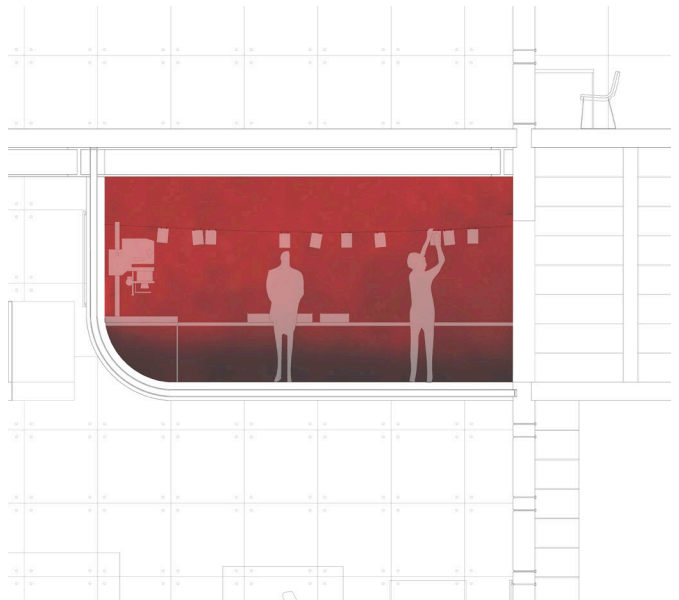

*Photo studio facing south-
west with direct sunlight*

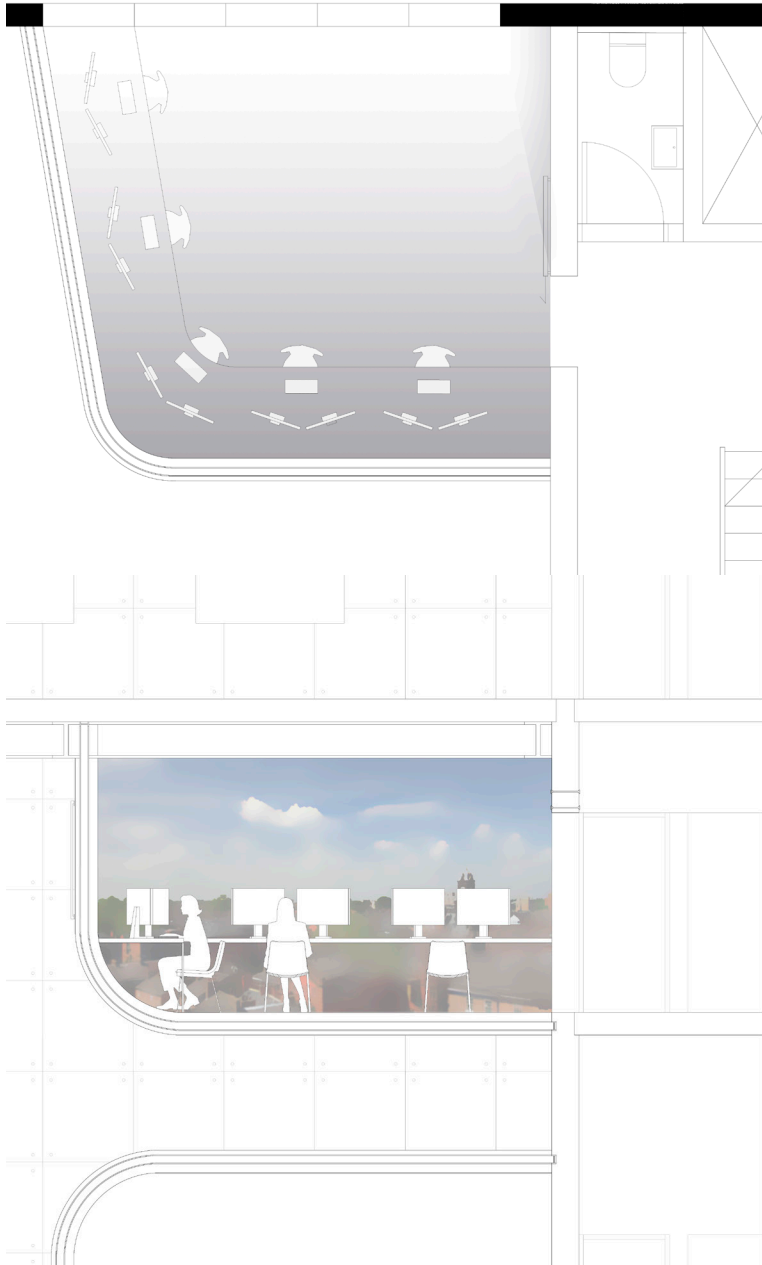

*Photo studio facing north
with indirect sunlight*

Darkroom



Digital workspaces



Hanging the art on concrete walls

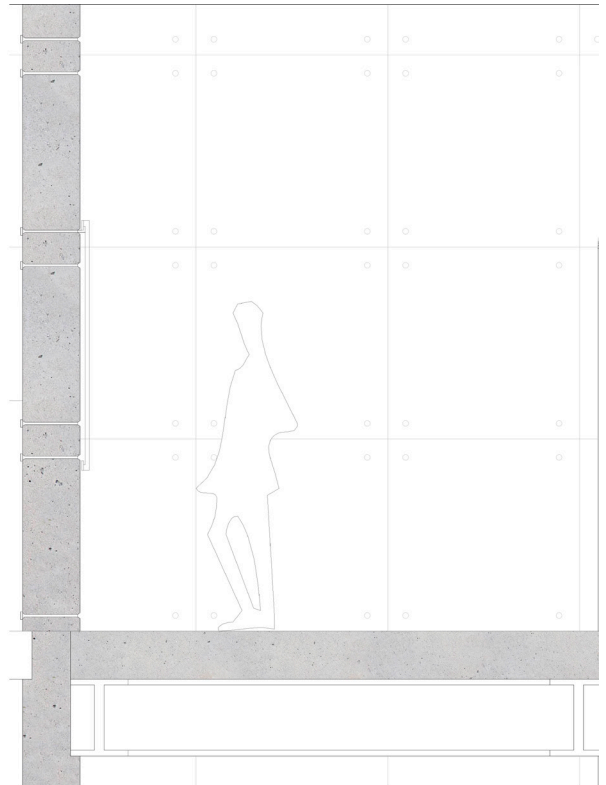

Using the cone holes in the cast for hanging the photographs

Sections of project

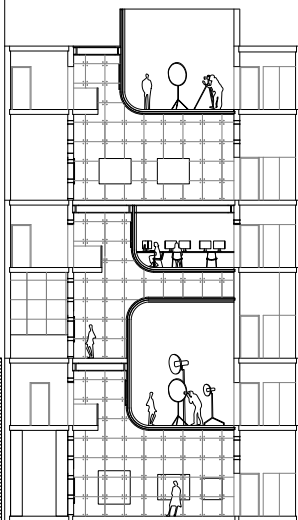
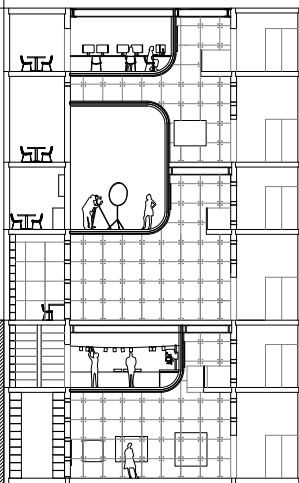

A desire to simplify the project lead me to a change. Simplifying the photo studios exterior shapes, creating one common shape instead. I also wanted to return to an earlier idea of the transportation of light vertically through the building. Having these thoughts, this concrete wall was created. The curves being a symbol of the photo studios at the same time leading light along it from the top to the very bottom floor.

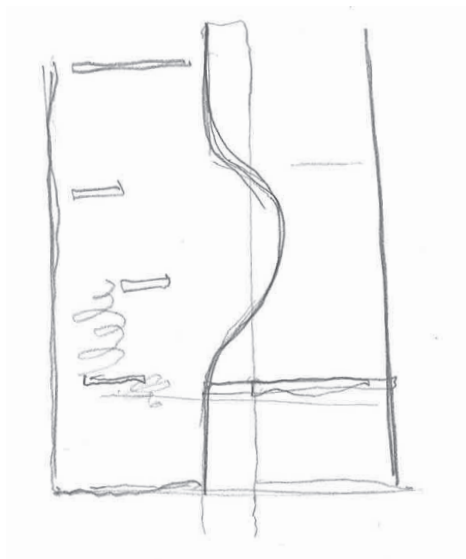
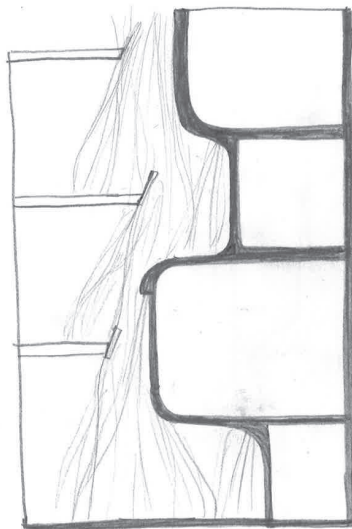

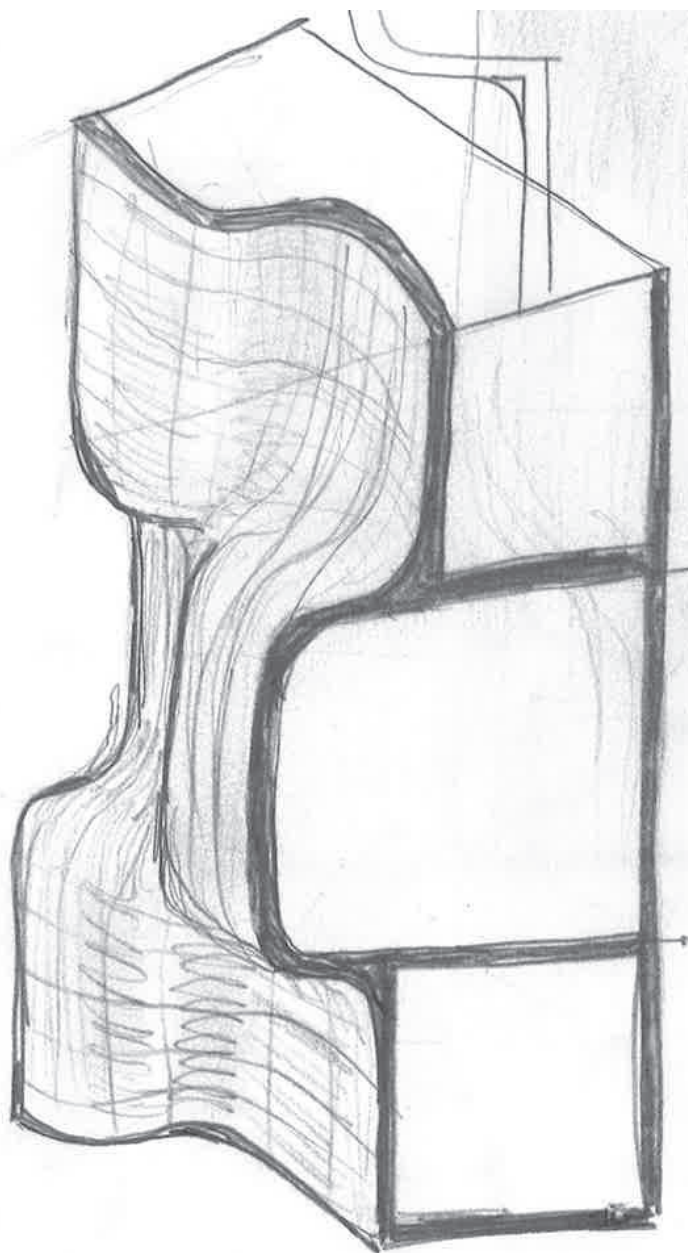

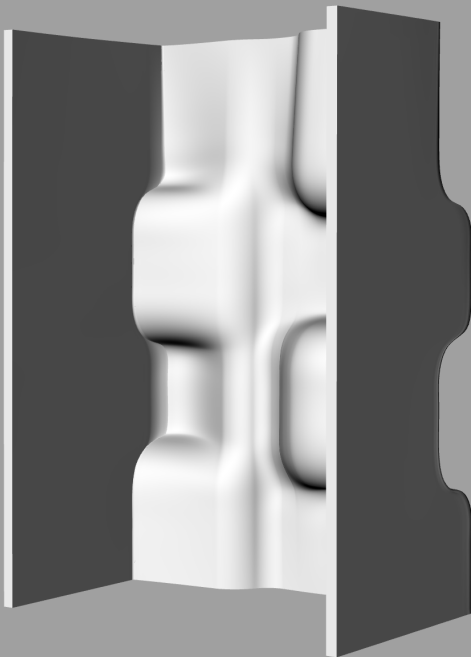
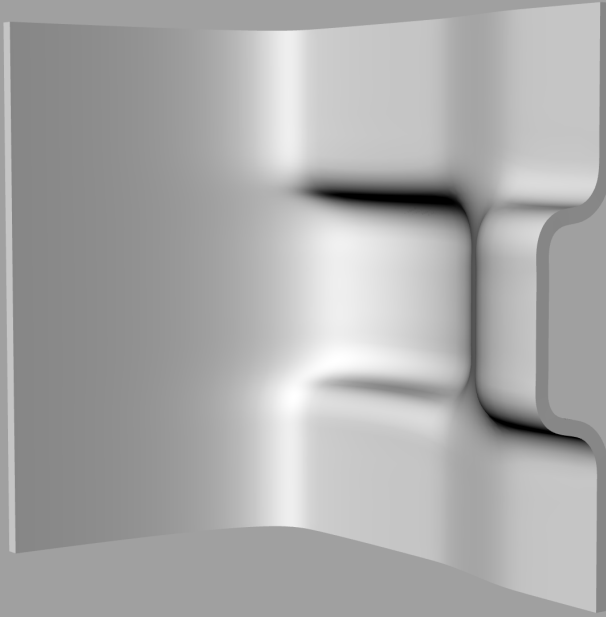

Testing the shape of the wall in 3D

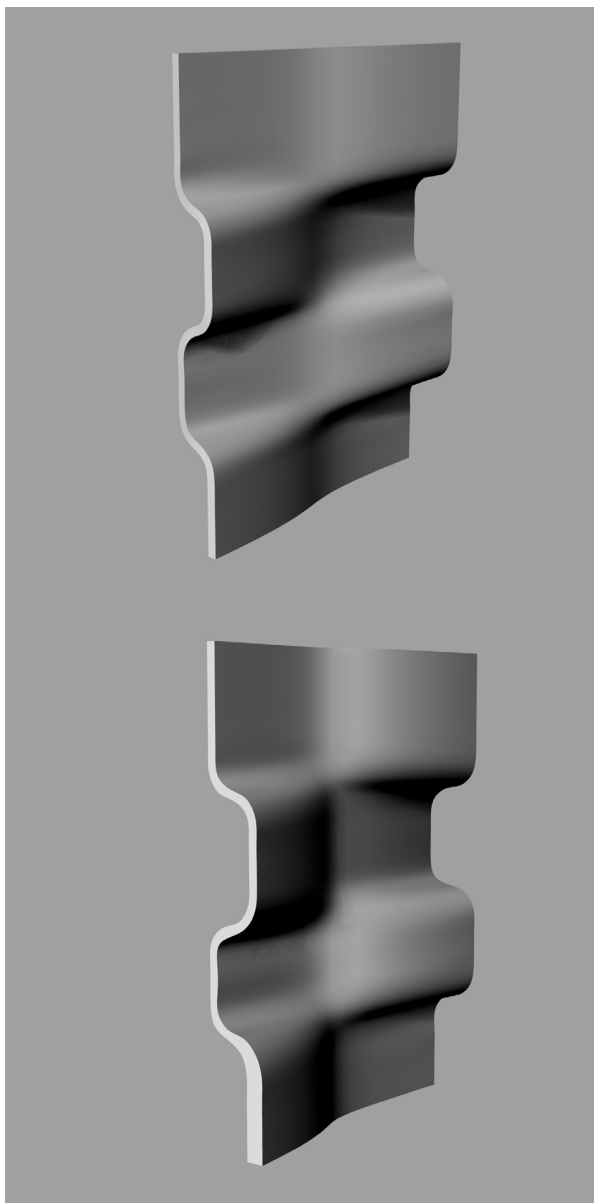

Cast of wall in 1:50

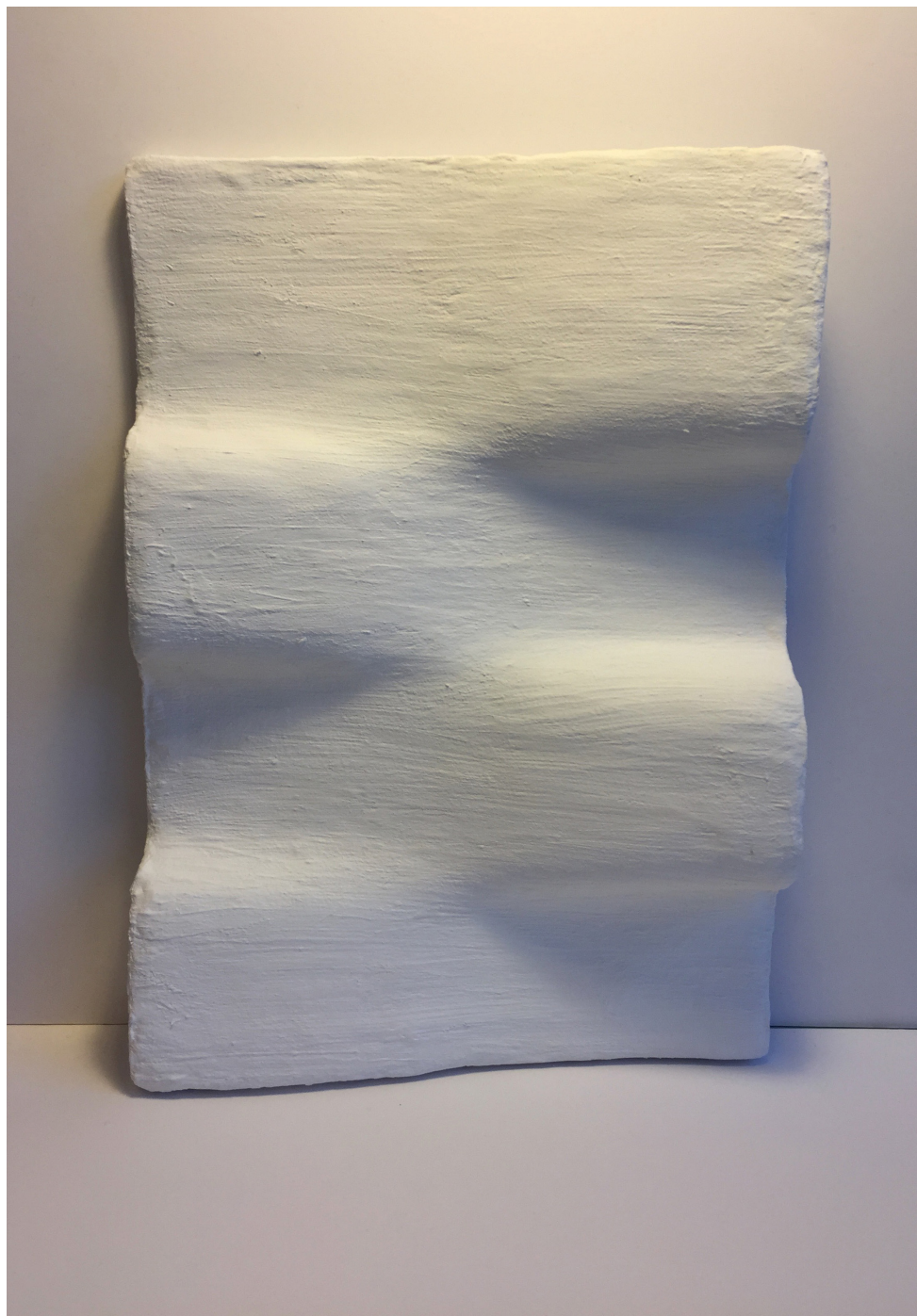



3D print 1:200

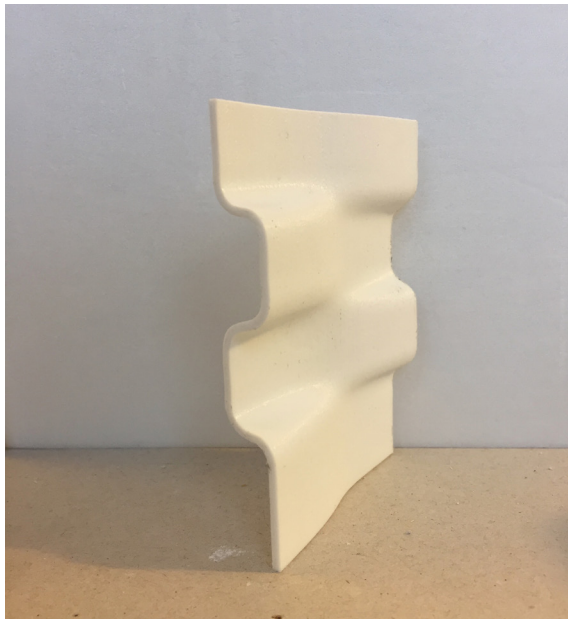

The courtyard

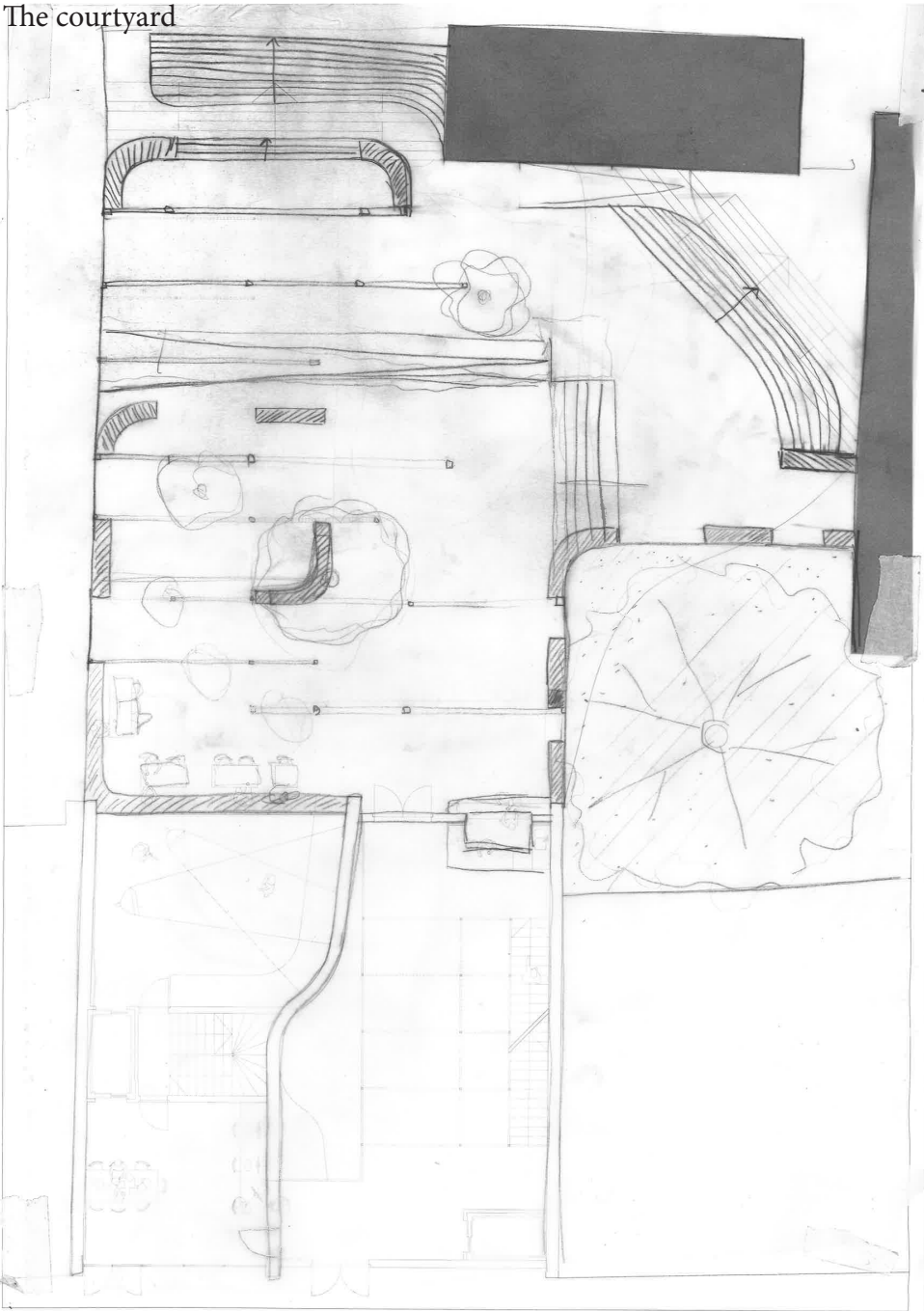

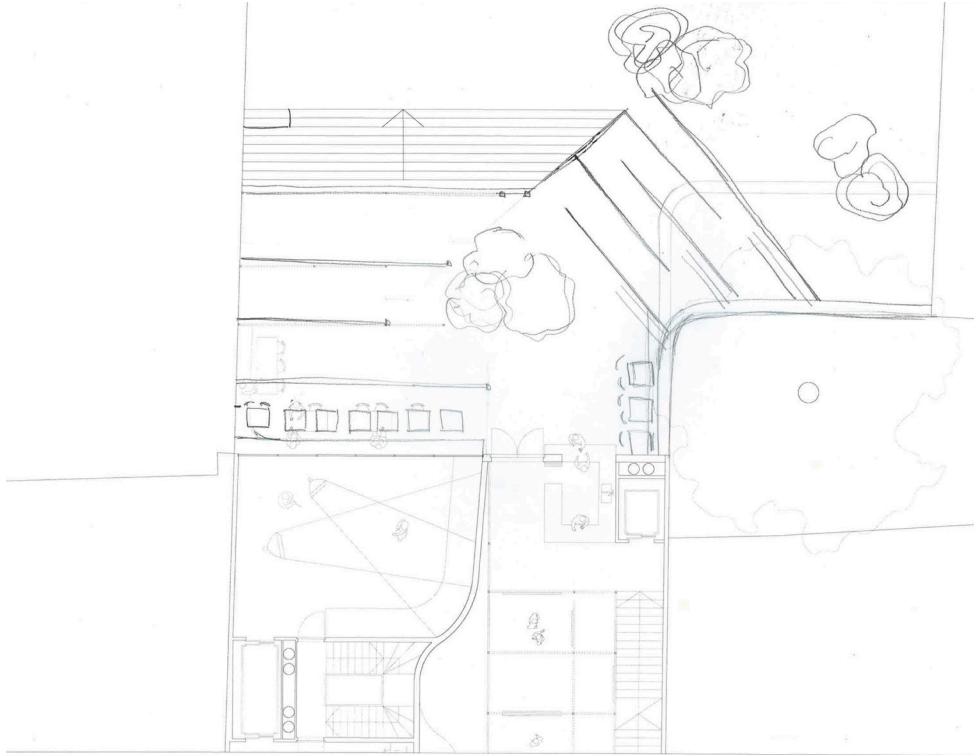

Creating a public space in the back of the building, to be accessed through the building or through the block. The space is to be used by the cafe/bar for outdoor serving and events, and as an exterior exhibition space open to the public.

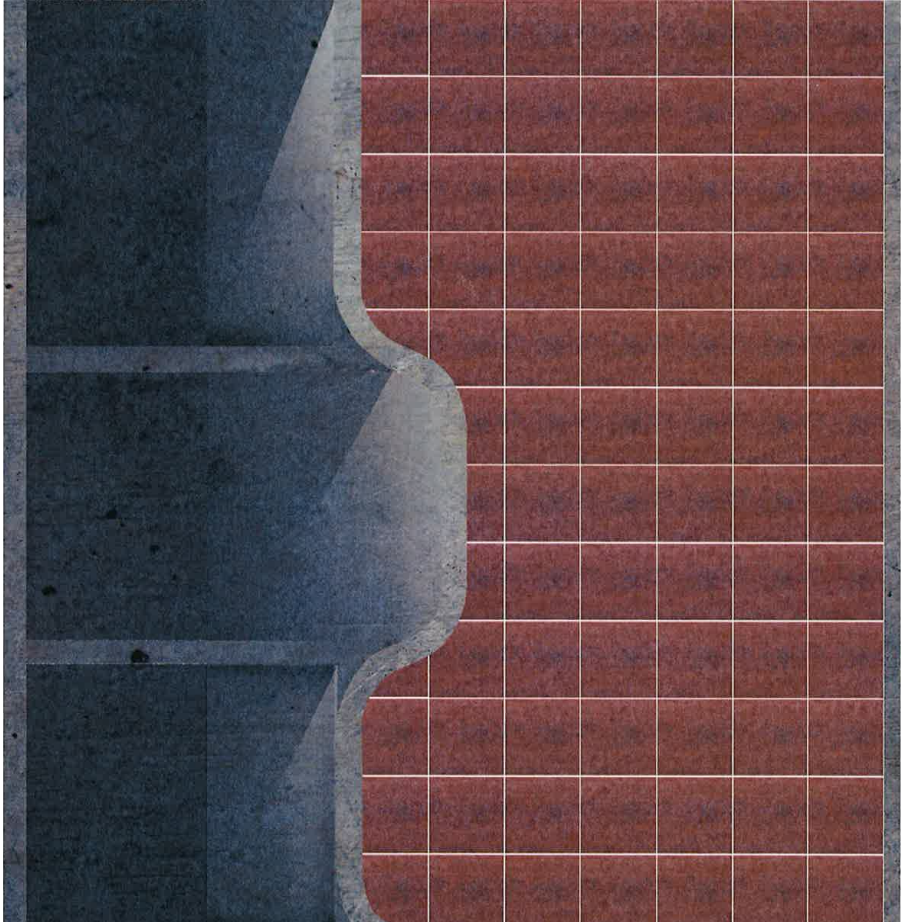

Testing the facade

The facade for the rooms for creating photography is open, to let natural light in and giving the photographer a connection with the world outside. The facade for the display of photography is closed, to be able

to control the light on the inside needed for the art

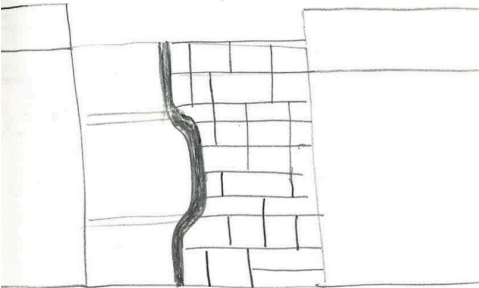
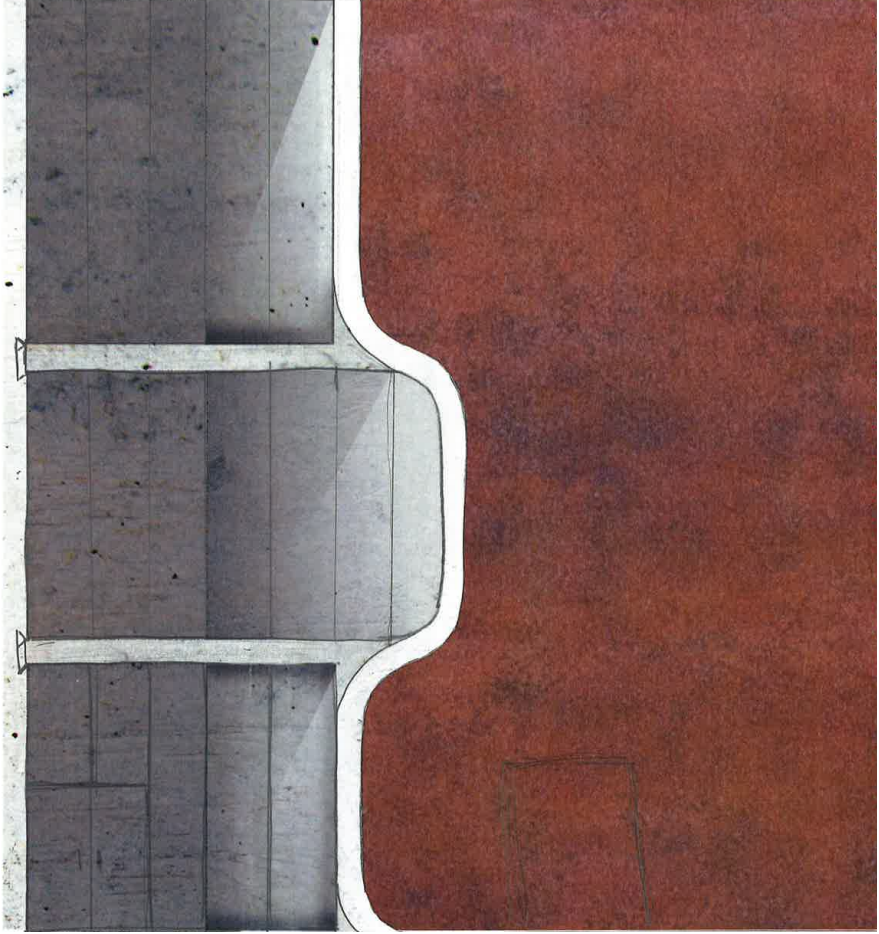

The concrete of the curved walls are visible.

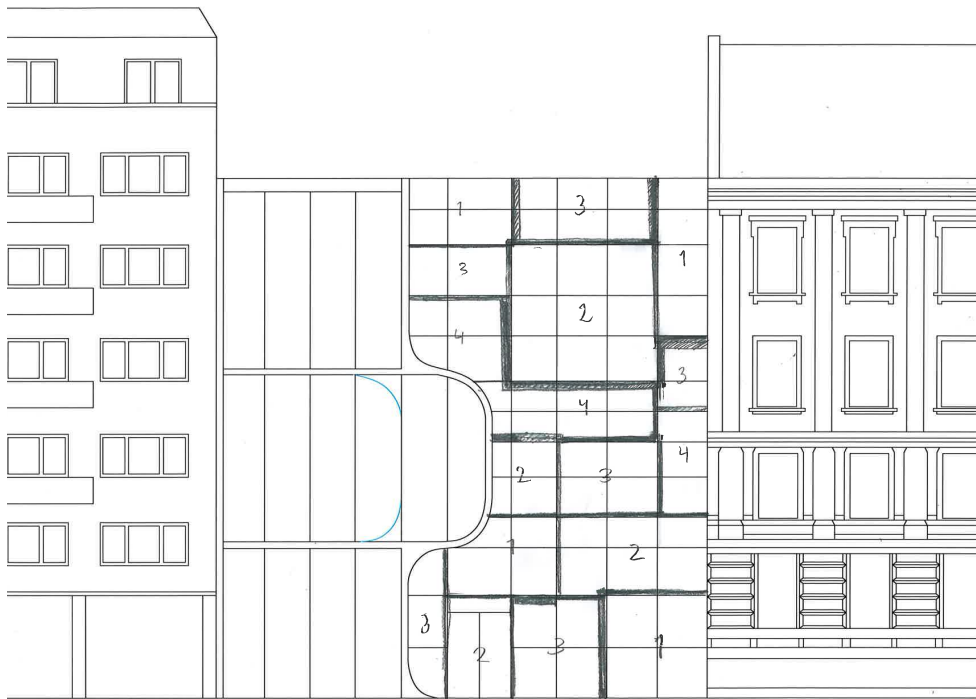

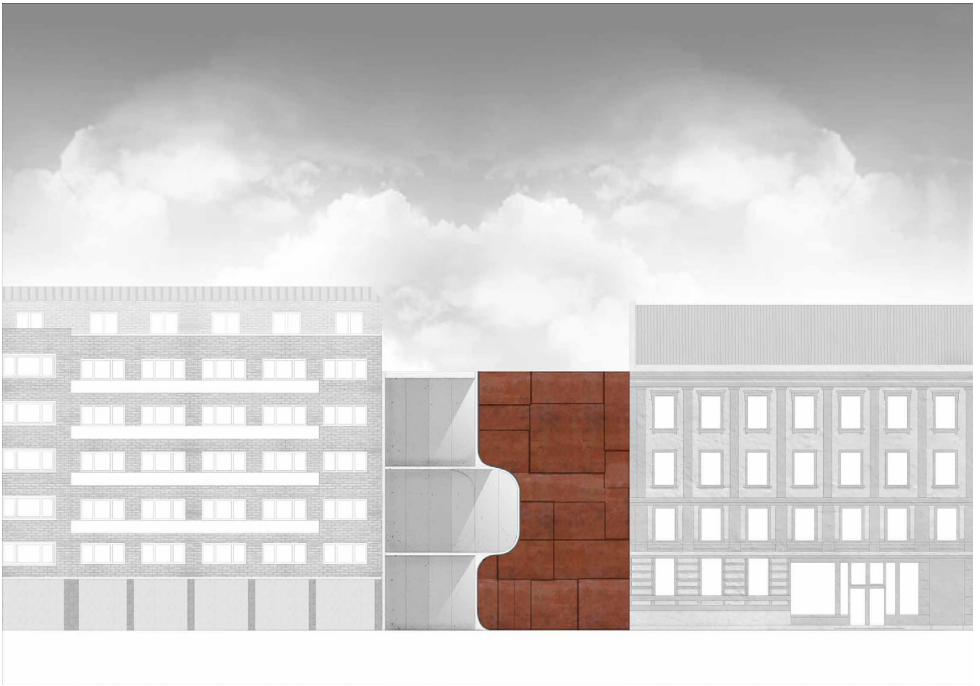

Two-dimensional corten steel plates overlapping and creating shadows, giving the closed facade a three-dimensionality

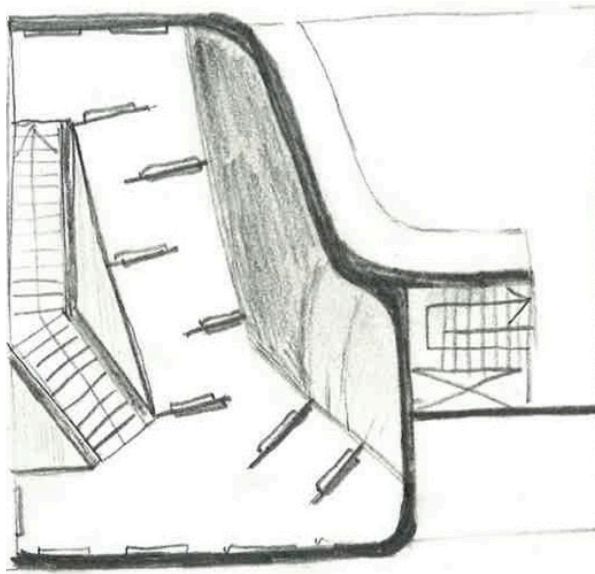

To transport the light through the building, the floors are not covering the whole space, providing openings where the light can travel.

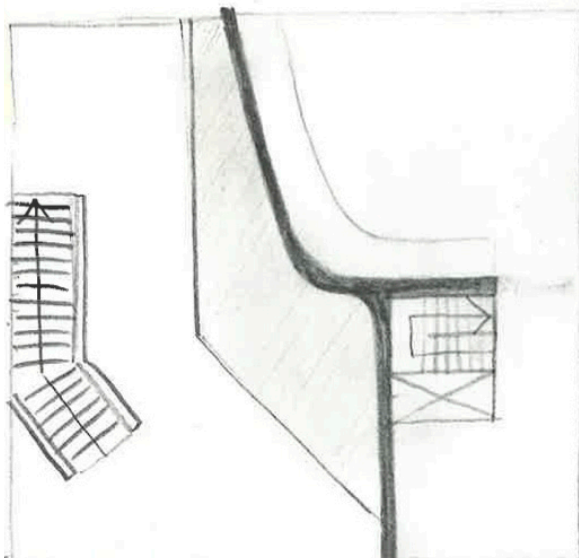

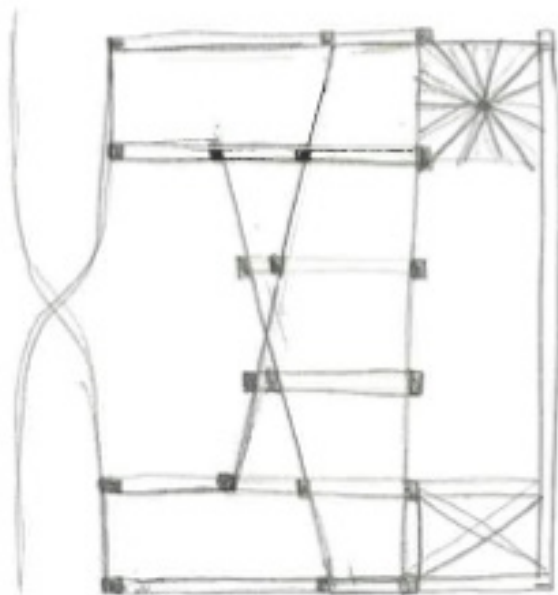
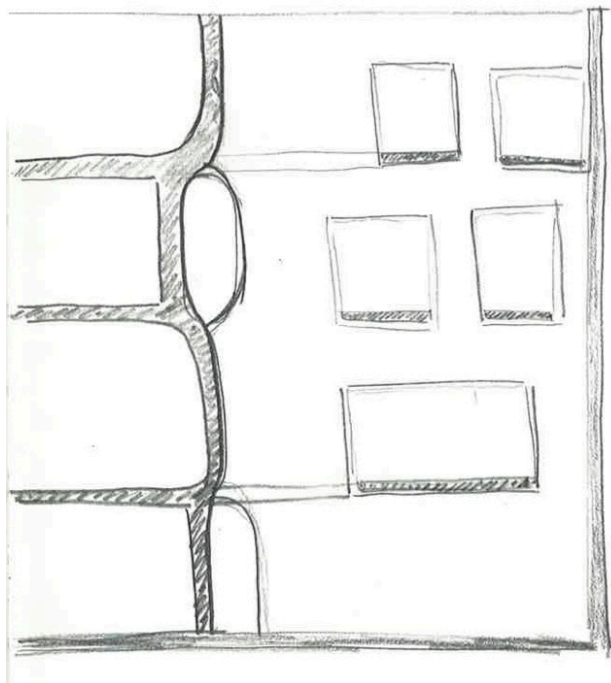

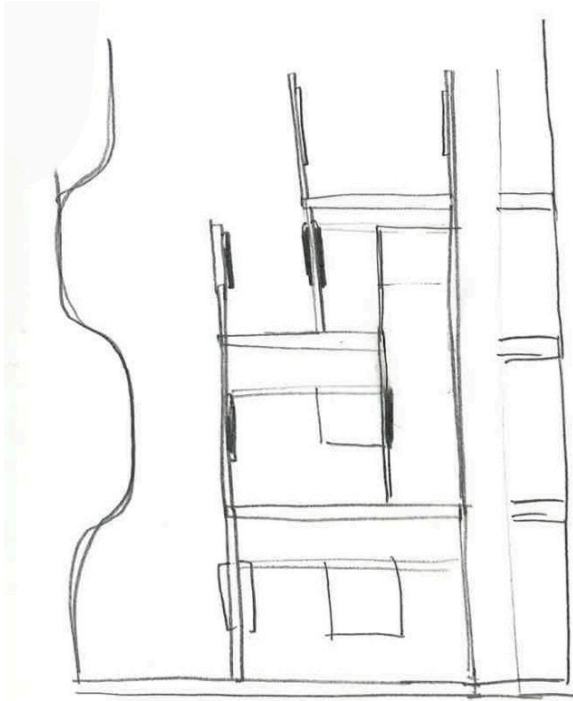

The system for hanging the photographs are in a rigid steel system, spanning between the four gallery floors.

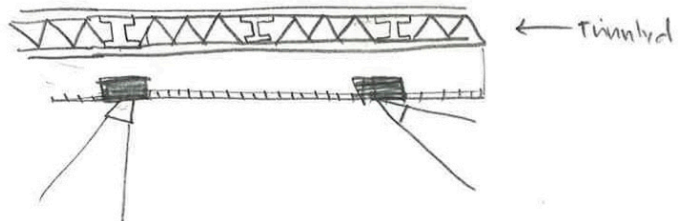

The technical systems needed are placed in the ceilings, such as lights that are adjustable to fit the variety in exhibitions.

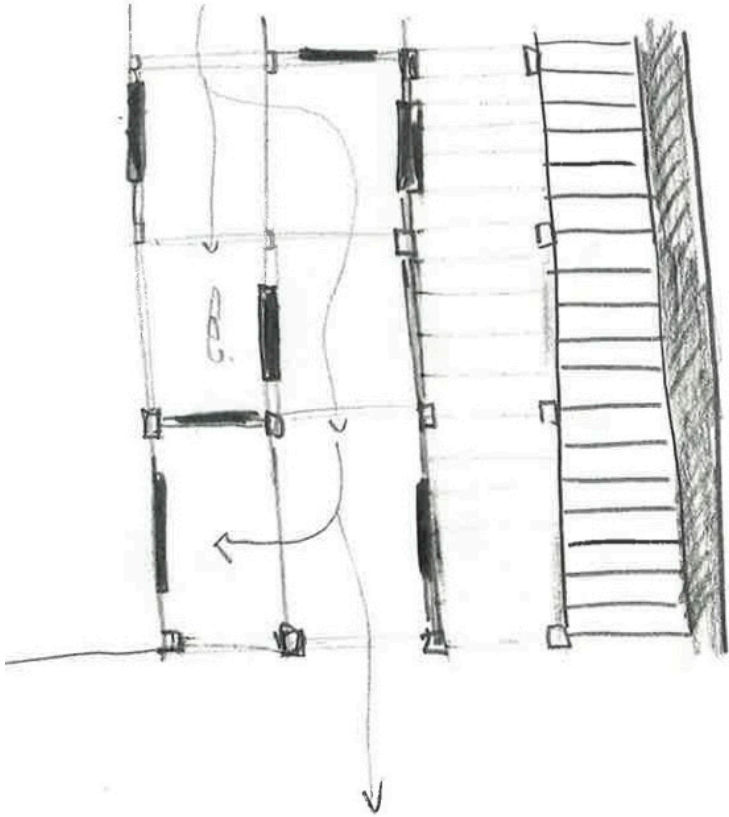

The steel system gives a flexibility in gallery situations and a free flow of people through it.

The stairs are included in the gallery as an exhibition space, being a part of the large open system.

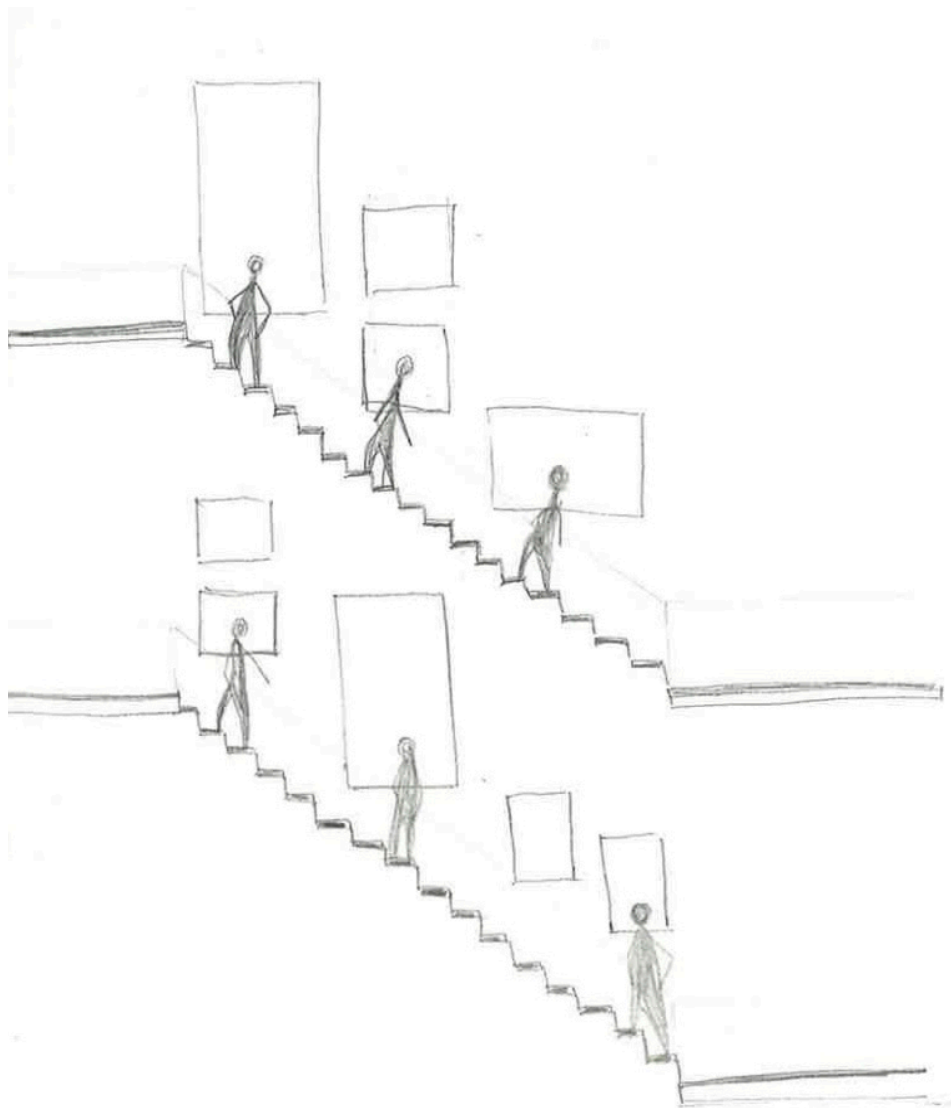

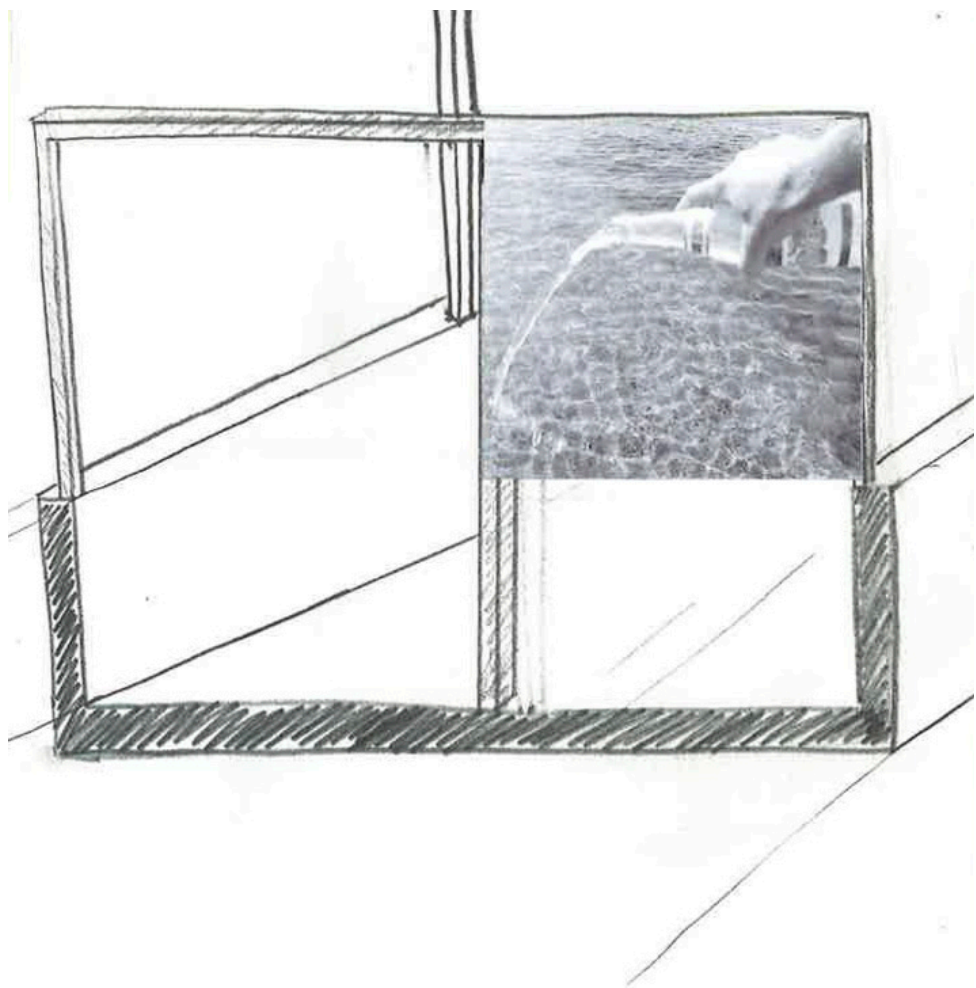

The roof

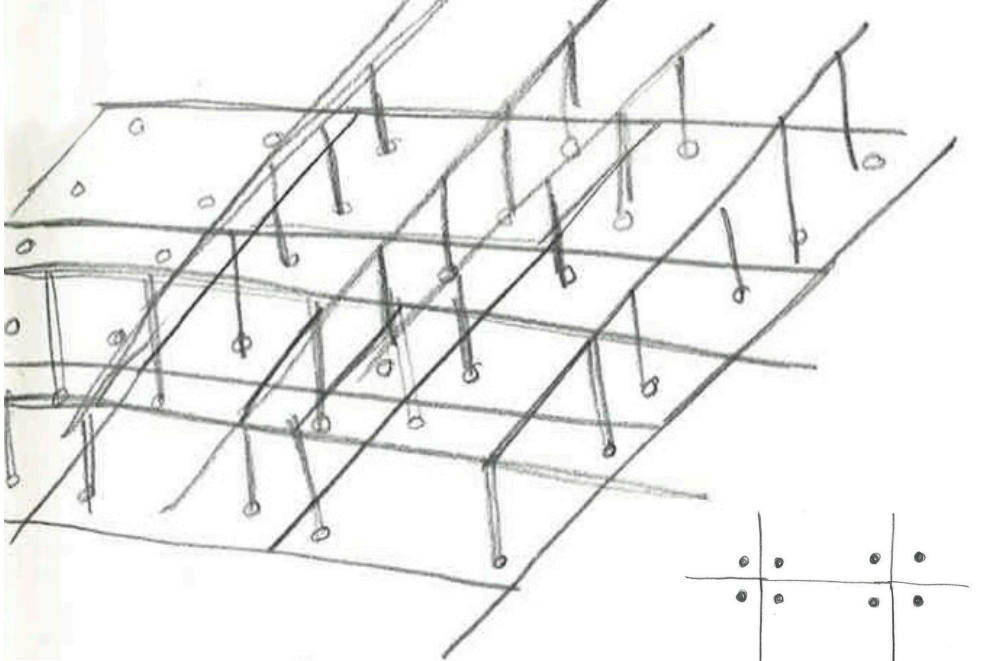

The photo studio at the top floor has a semi translucent ceiling, with exterior construction. Providing the right light for the studio without giving unnecessary shadows.

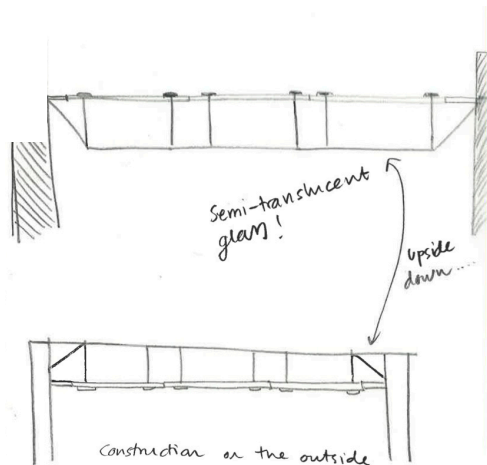

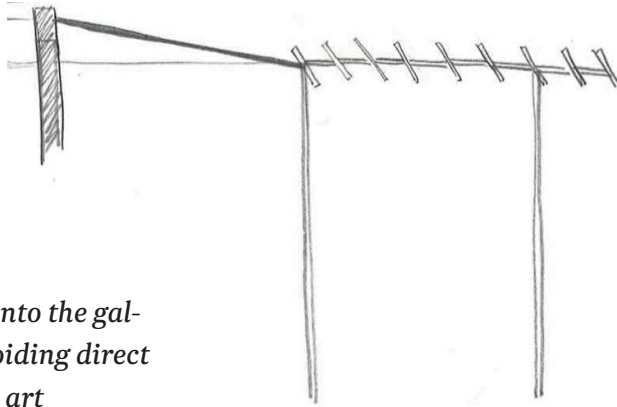

Filtering light into the gallery rooms, avoiding direct sunlight on the art

The roof over the gallery spaces is open to allow light to enter and travel down the concrete curved wall. To prevent direct sunlight on the photographs on the top floor, sun shading is used.

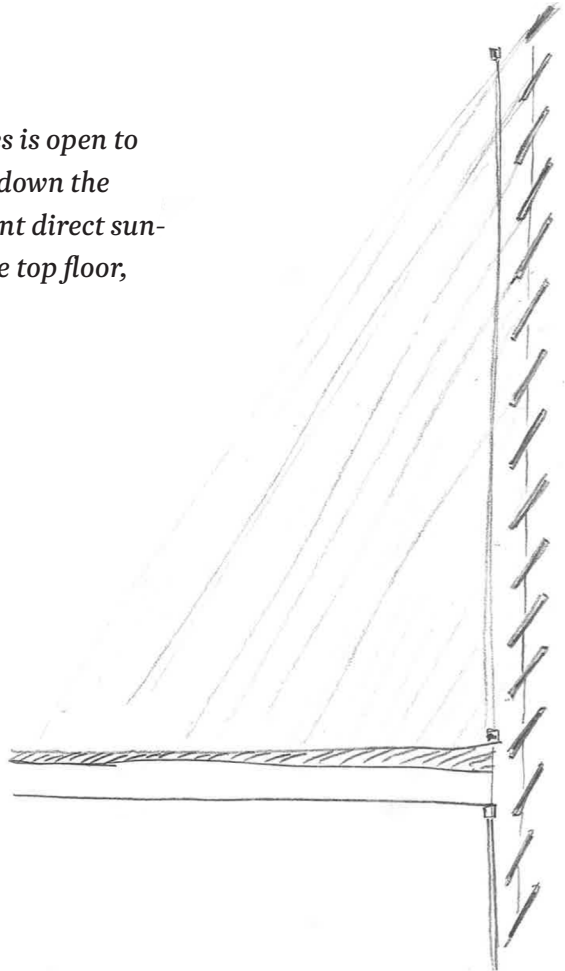

Sections through the building

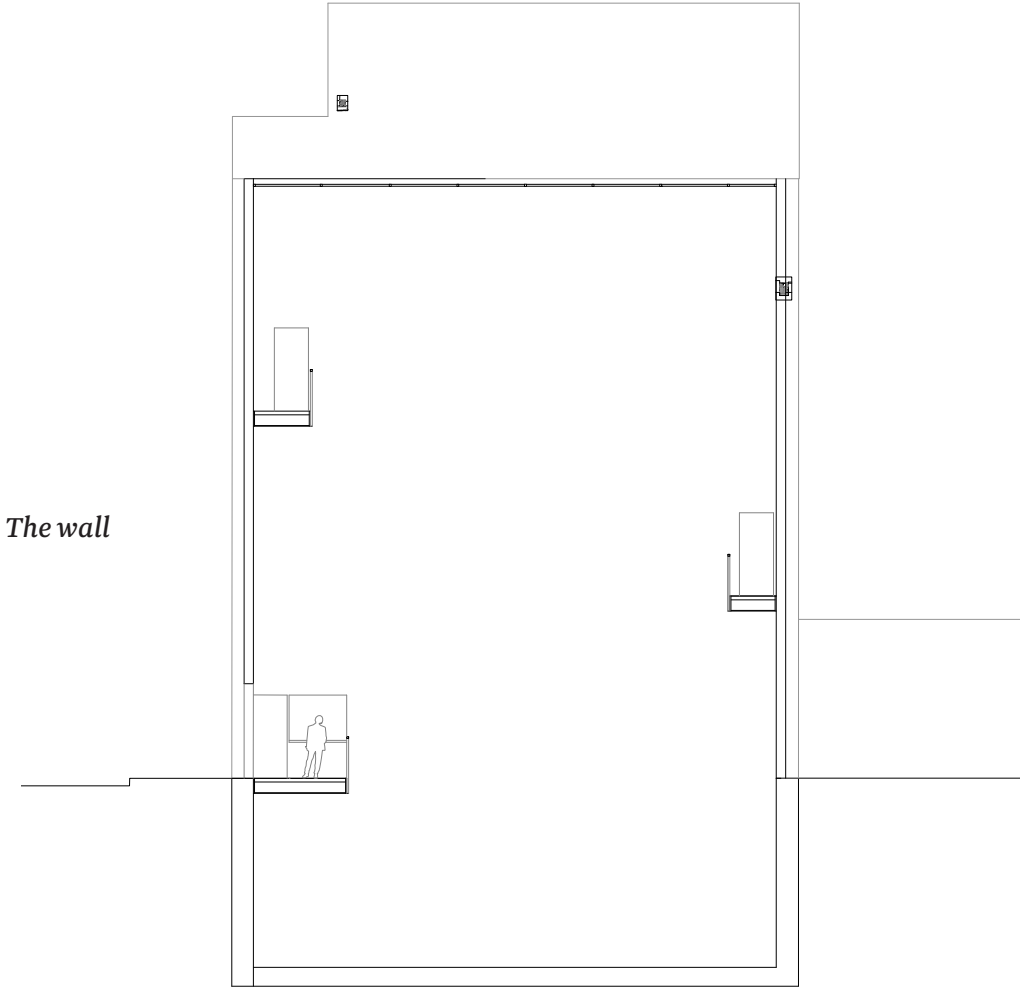

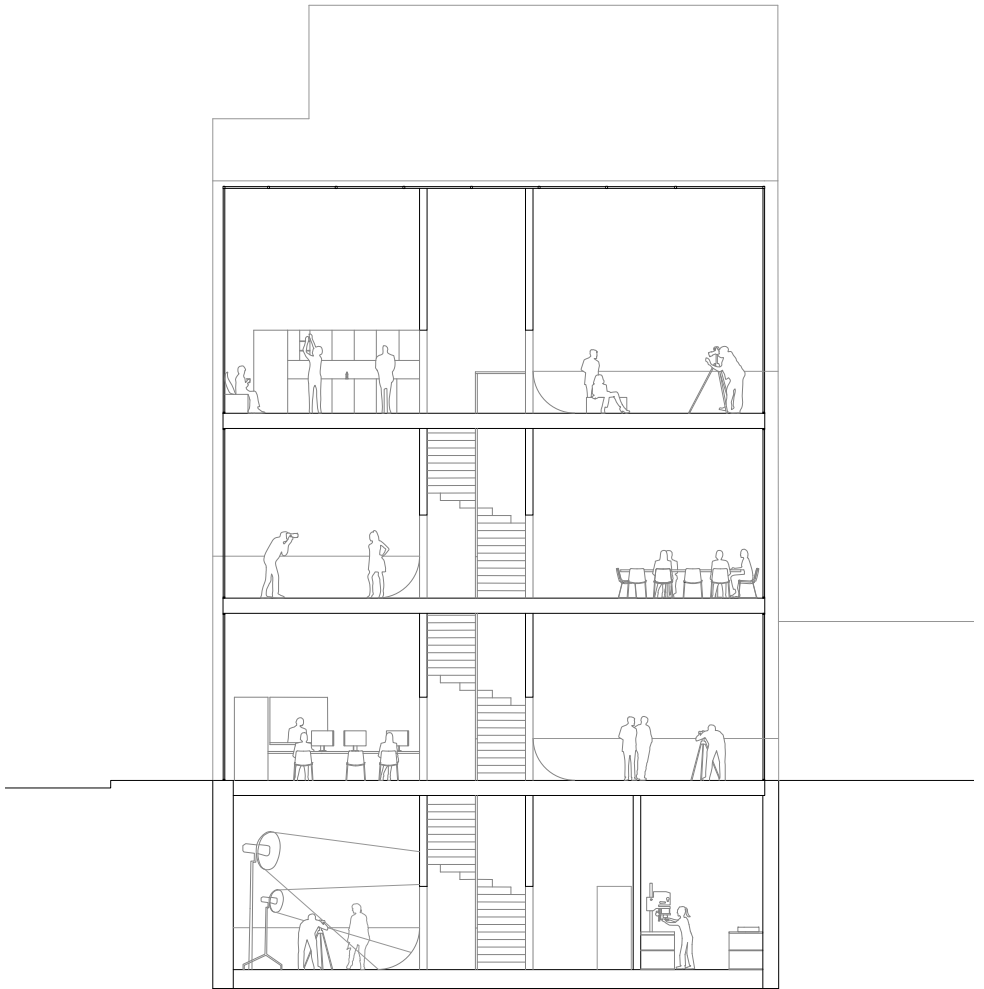

The spaces for the photographer

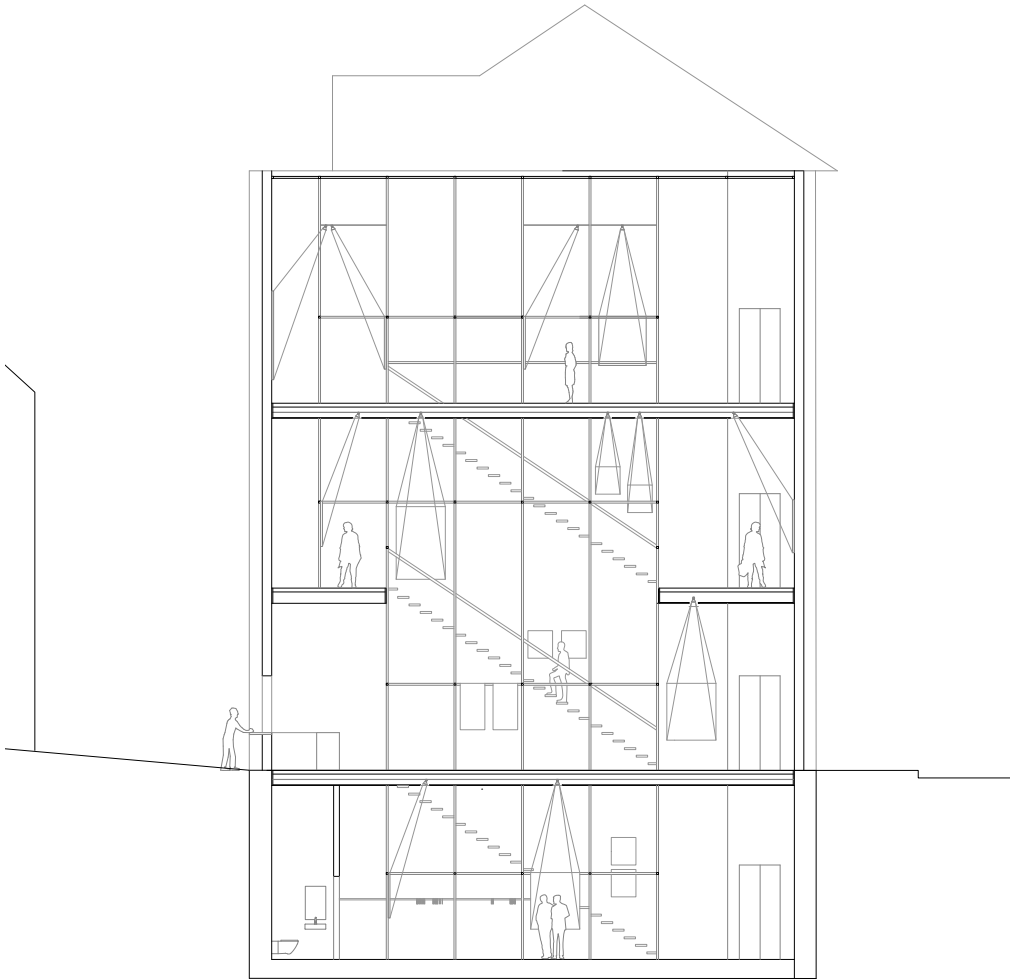

The gallery spaces

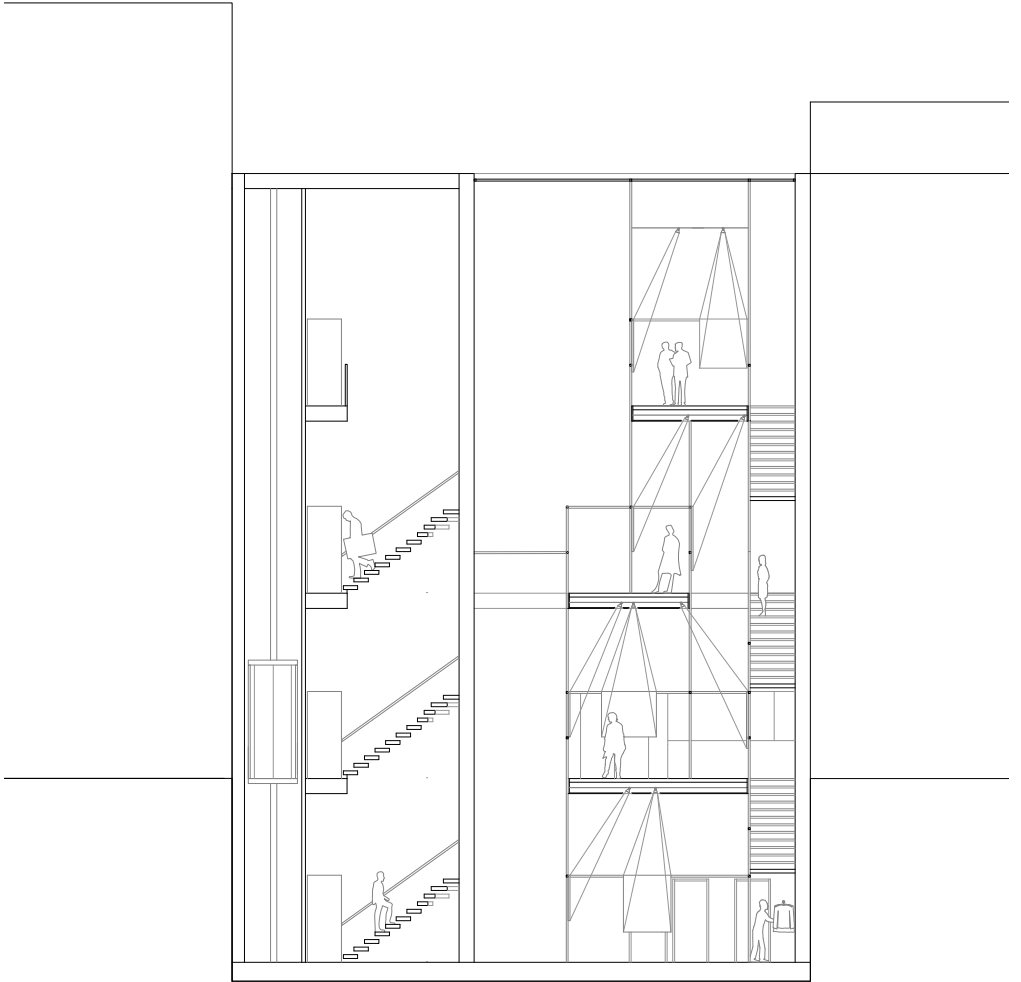

Vertical communications

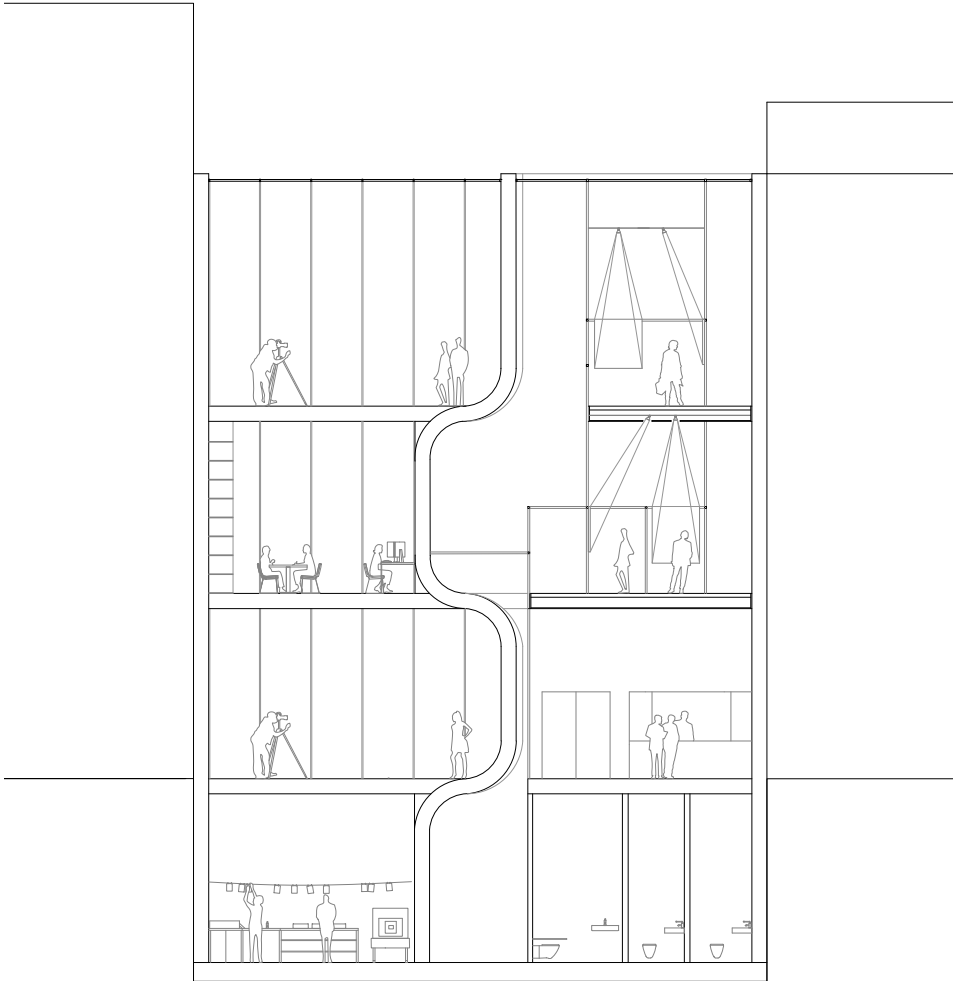

The two parallel programs

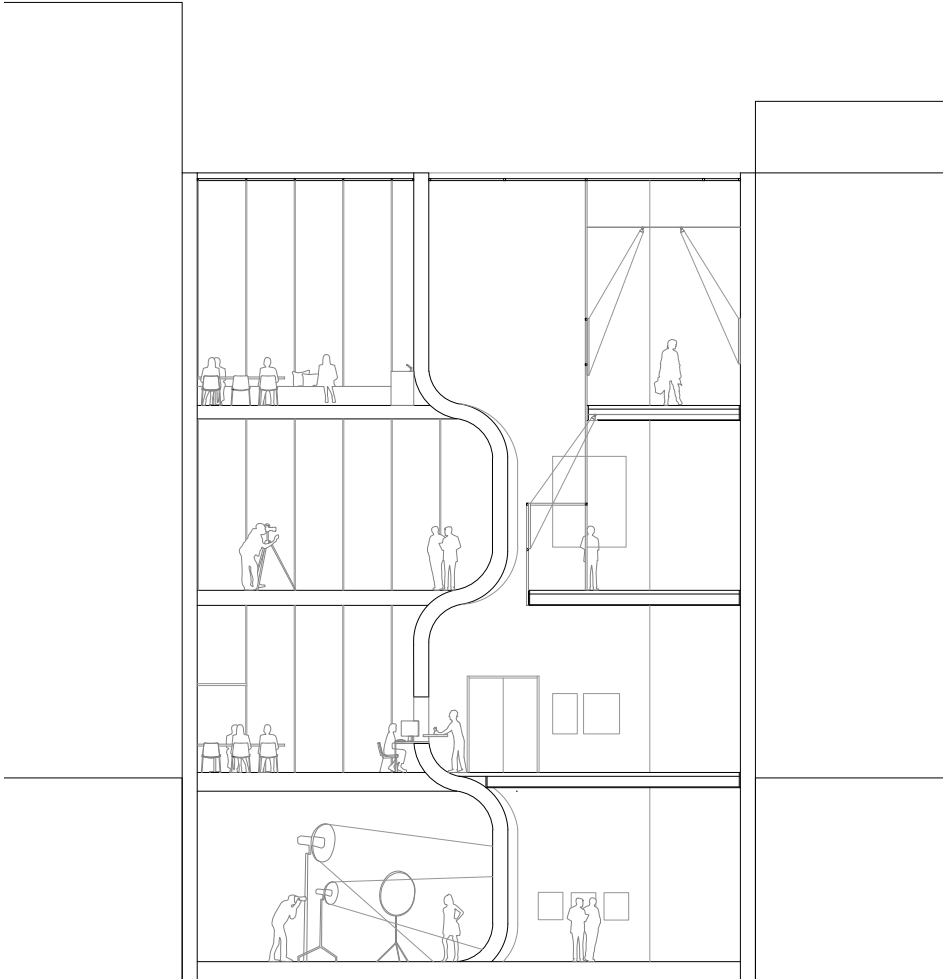

The two parallel programs

Plan U

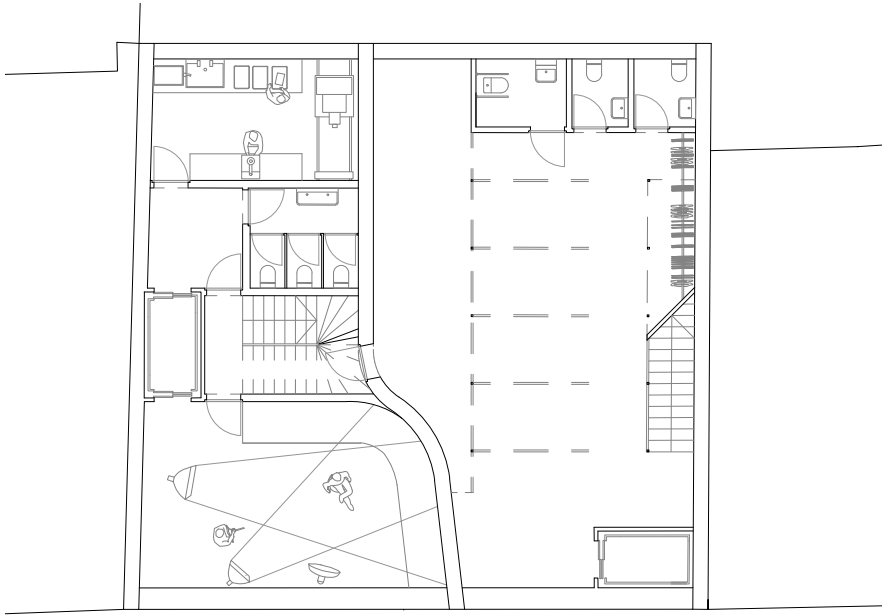

Ground floor

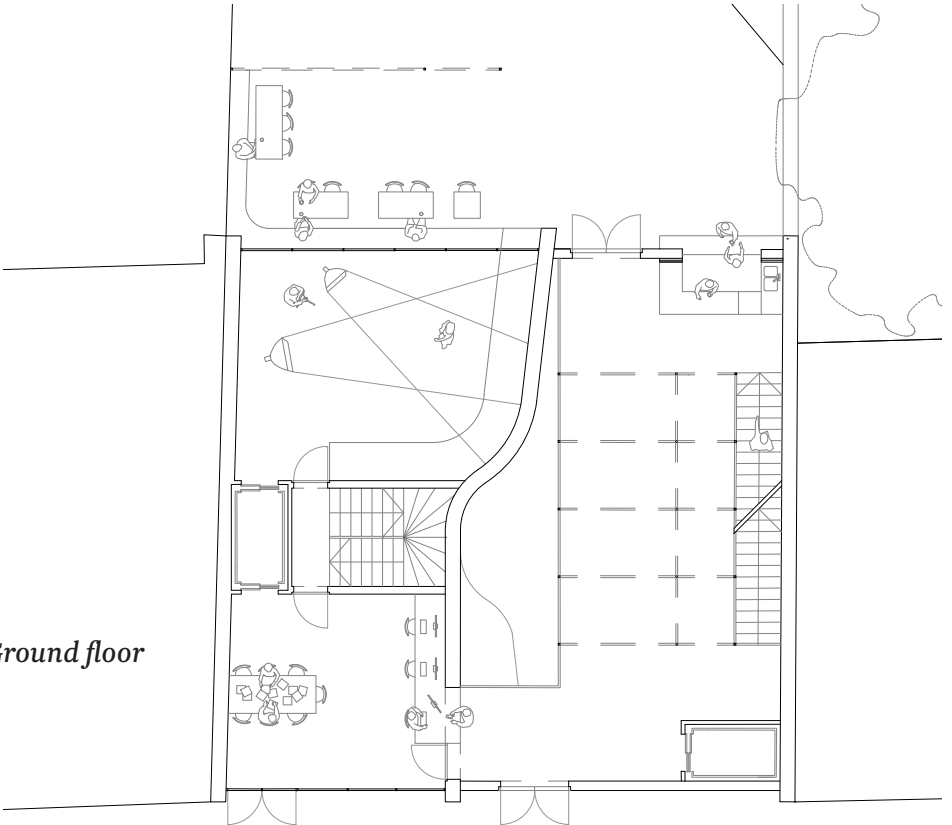

First floor

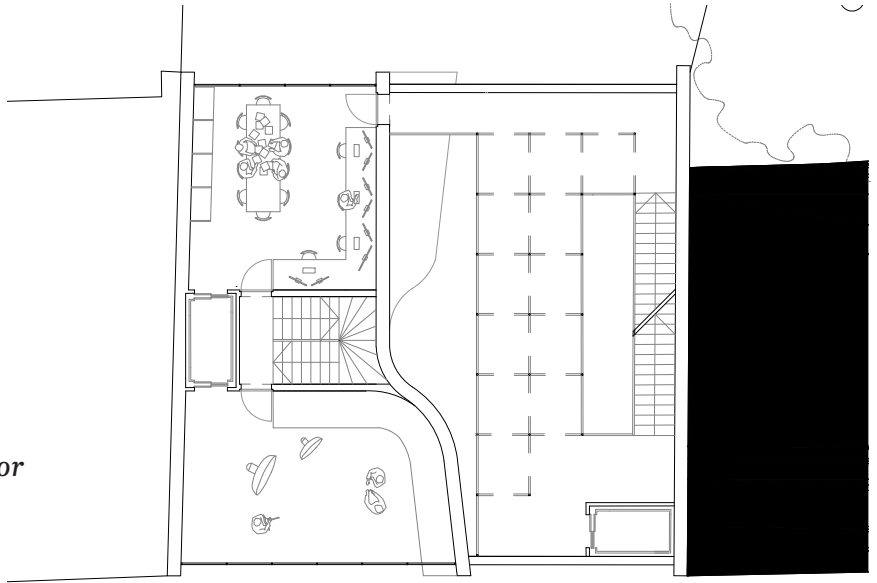

Second floor

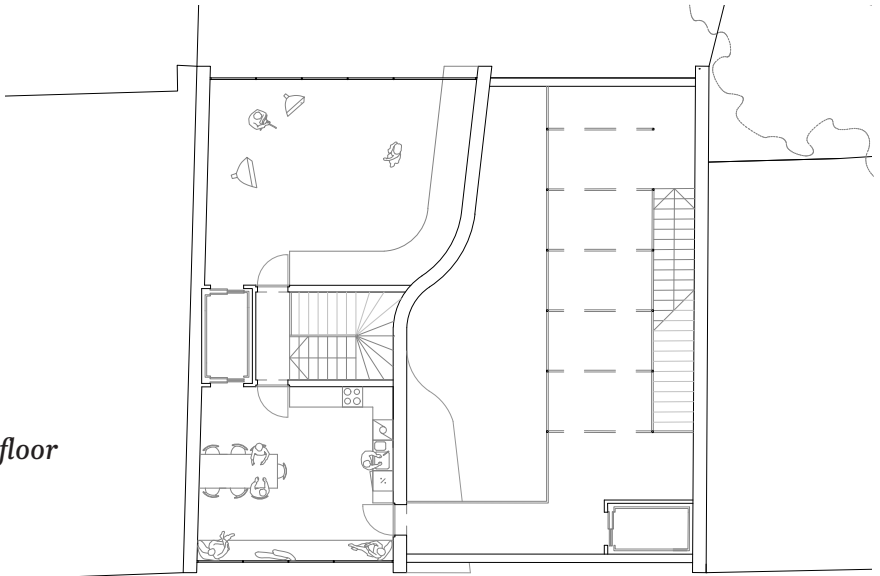

This is the end of the process. The final changes and the result can be seen in the exhibition and presentation.