

The bicycle trip



First day in Eidsvoll Park.



We set up our tent in the forest.

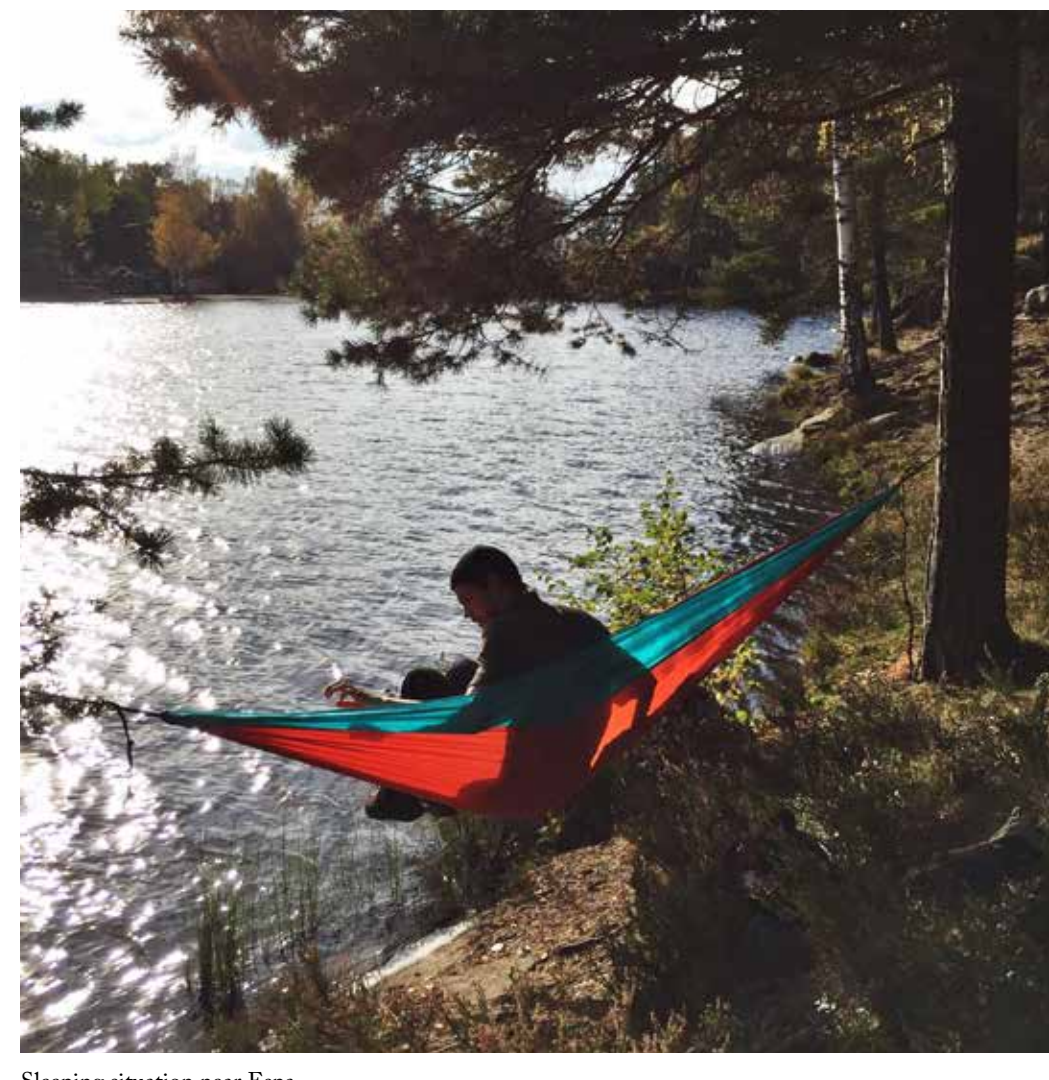

Relaxing in a hammock over the river.



Barn near Beret with an active program, an open structure in good condition with minimal need of maintenance. Property: 12496.



Barn located in Ekeberg. Older barn with high quality construction using the 'tjelle' technique. The structure is sturdy, dry, and well-maintained. The barn consists of three smaller sections with an old storage. Property: 12497.



Barn located in the middle of a hill in Beret. The barn is in good condition with the same wooden structure 100 years. One big open room will need some refurbishment and there is an active program using the 'tjelle' technique.

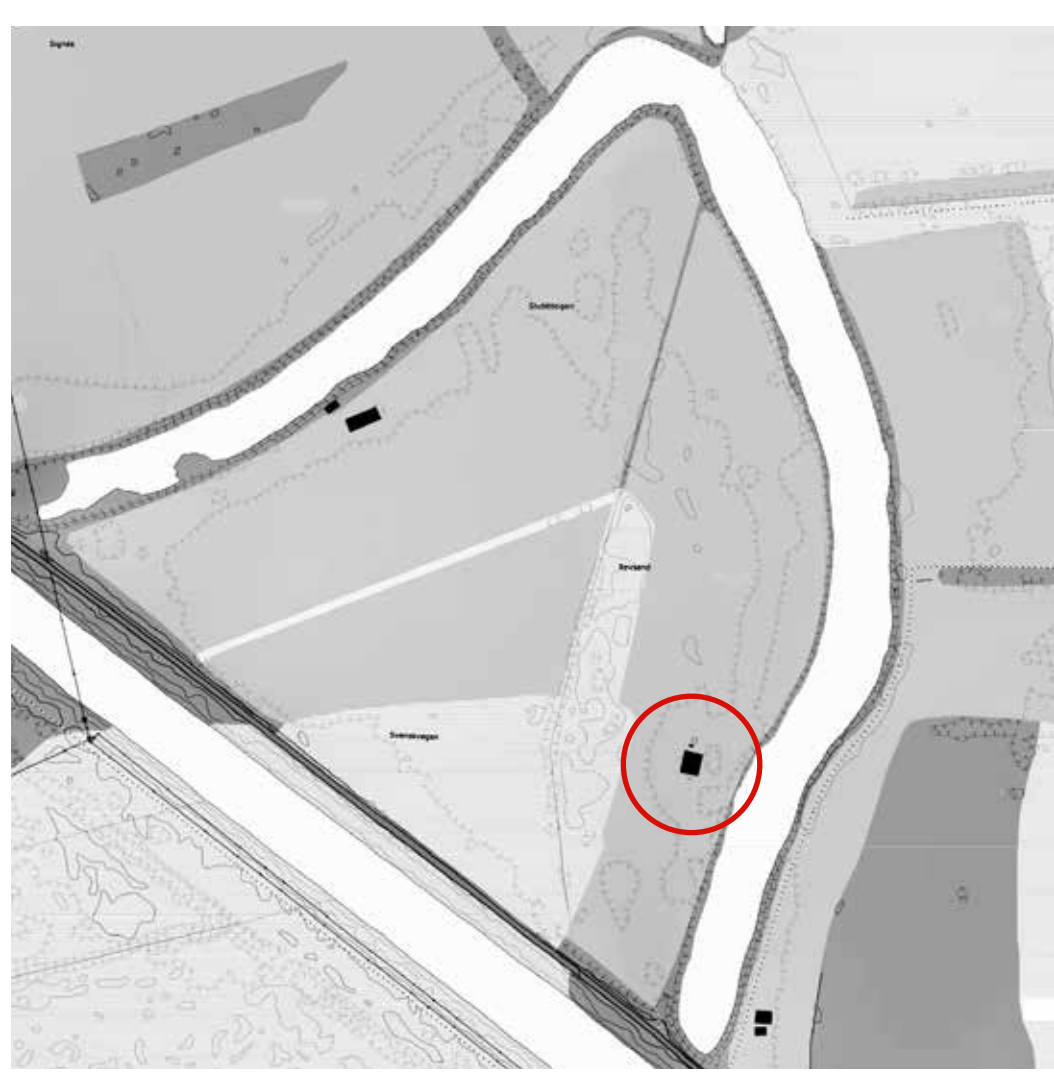

Site plan showing the barn in the middle of the field in Beret.

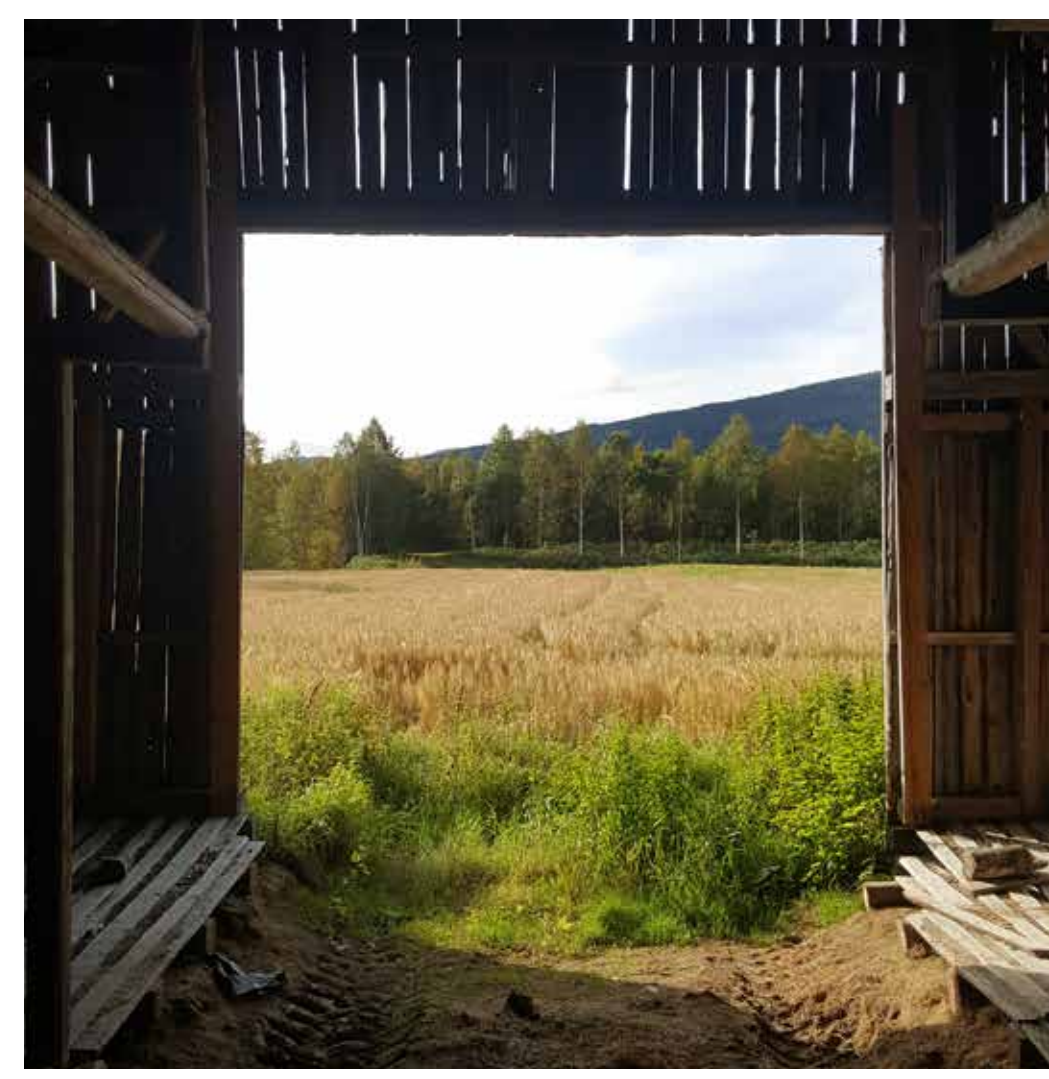

The barn in Rendalen

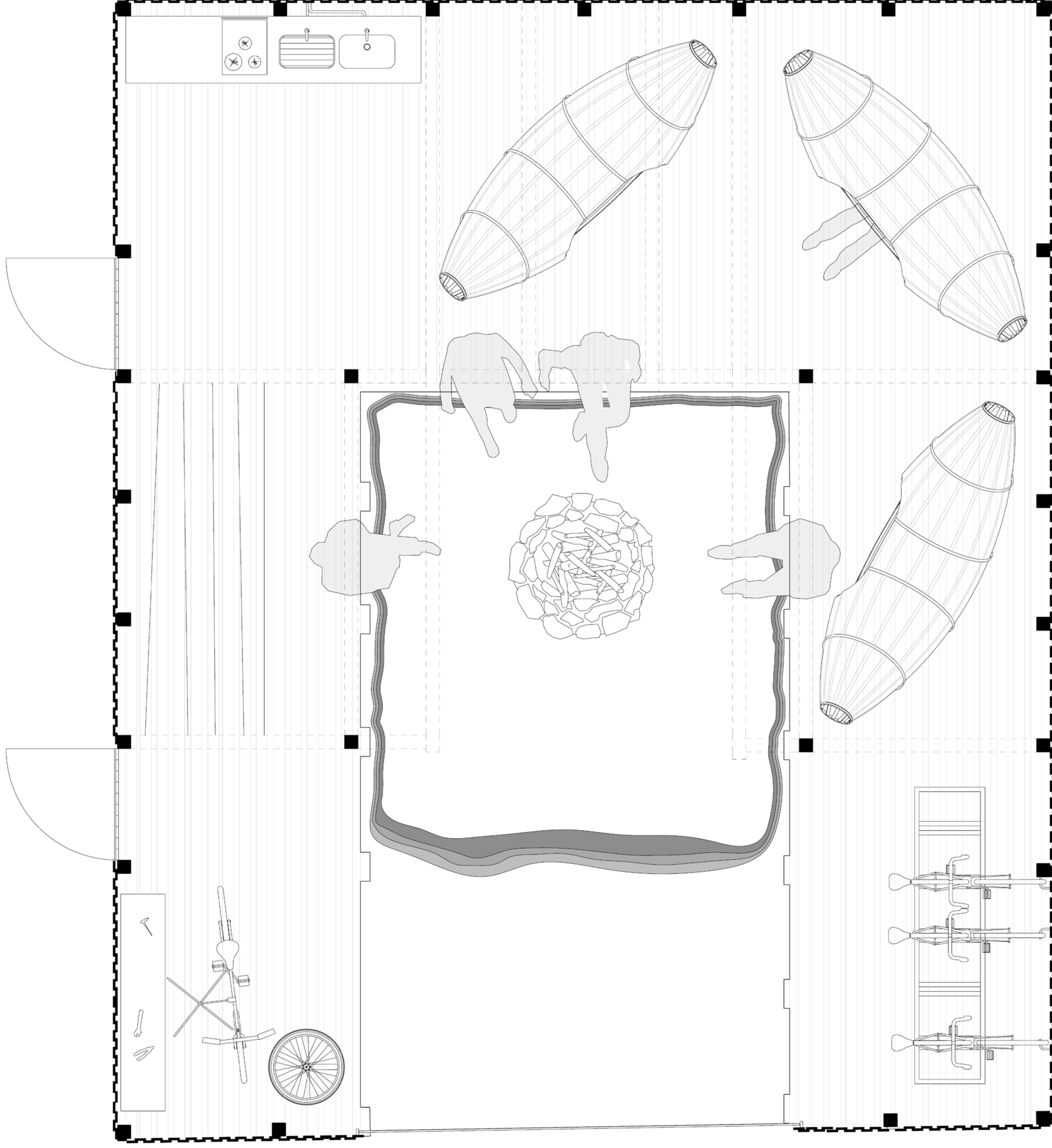

Plan 1:20

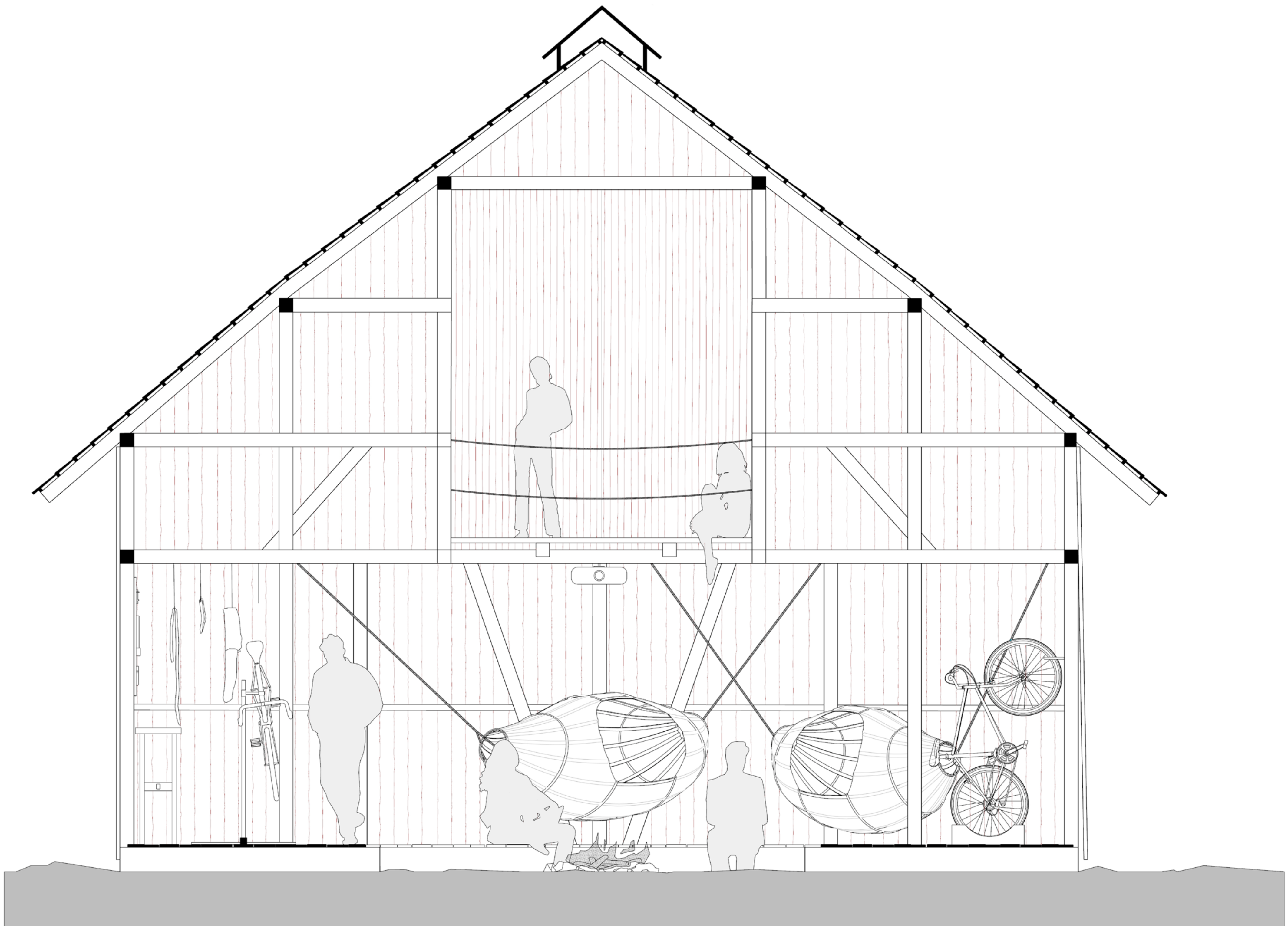

Section 1:20

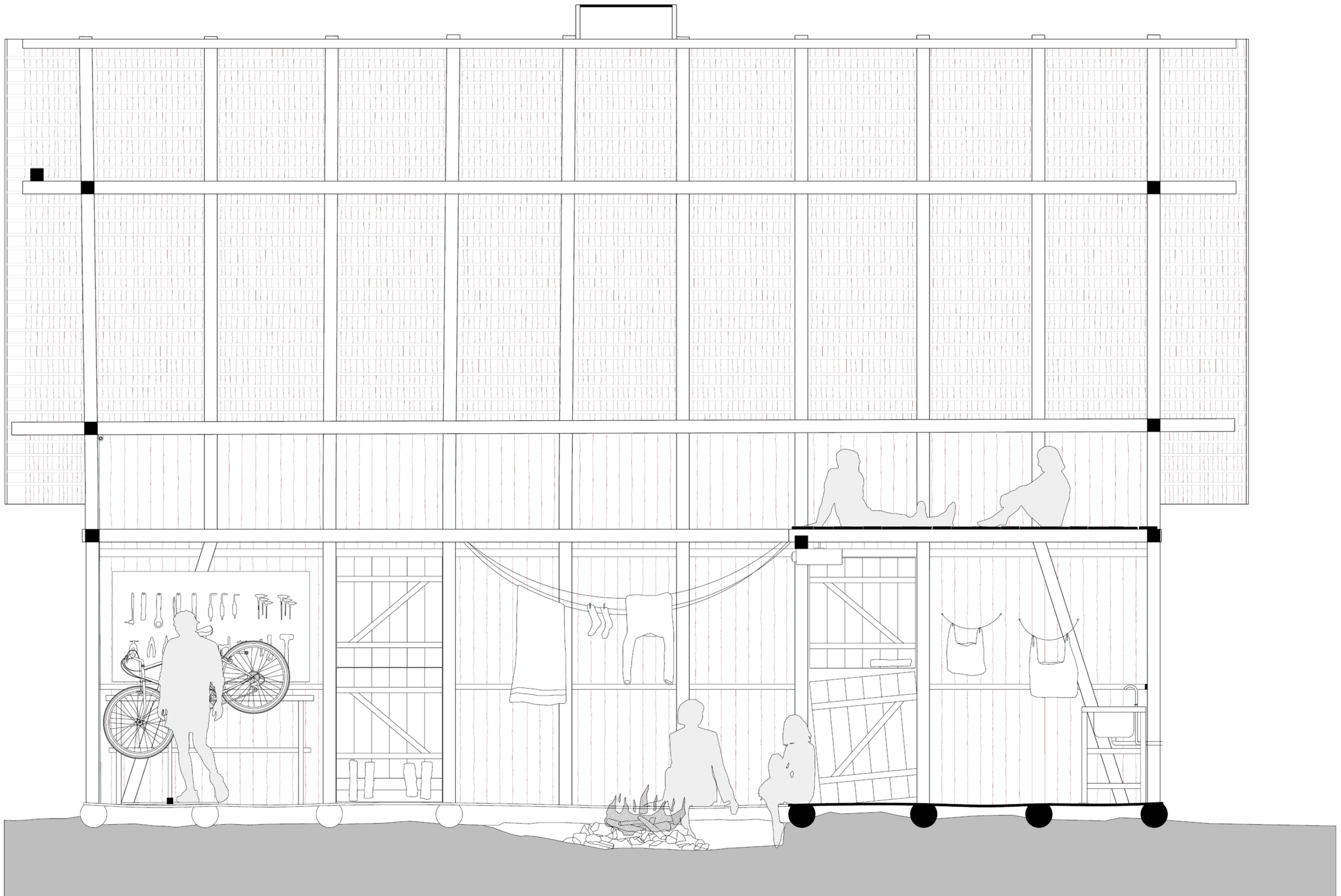

Section 1:20

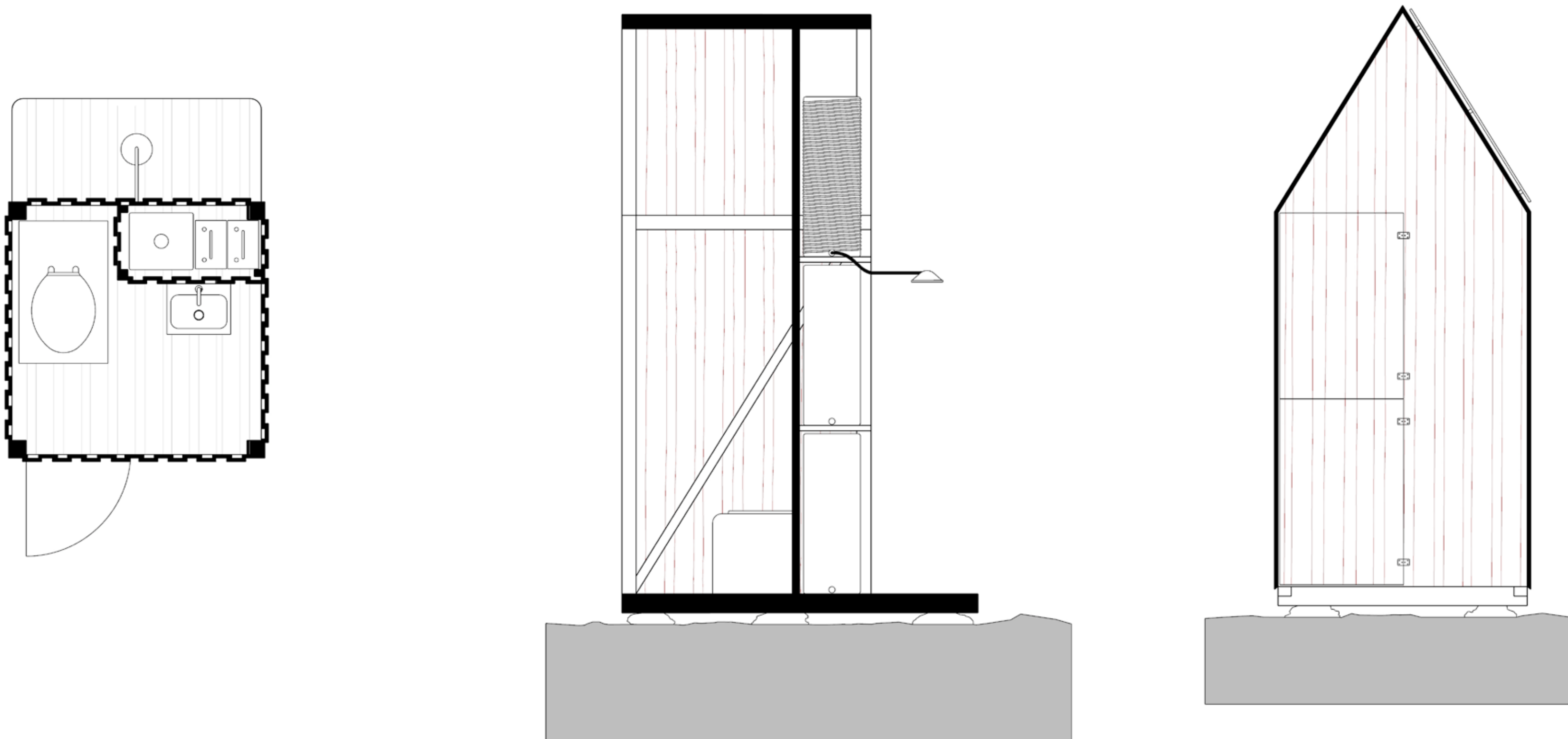

Plan 1:20

The pod

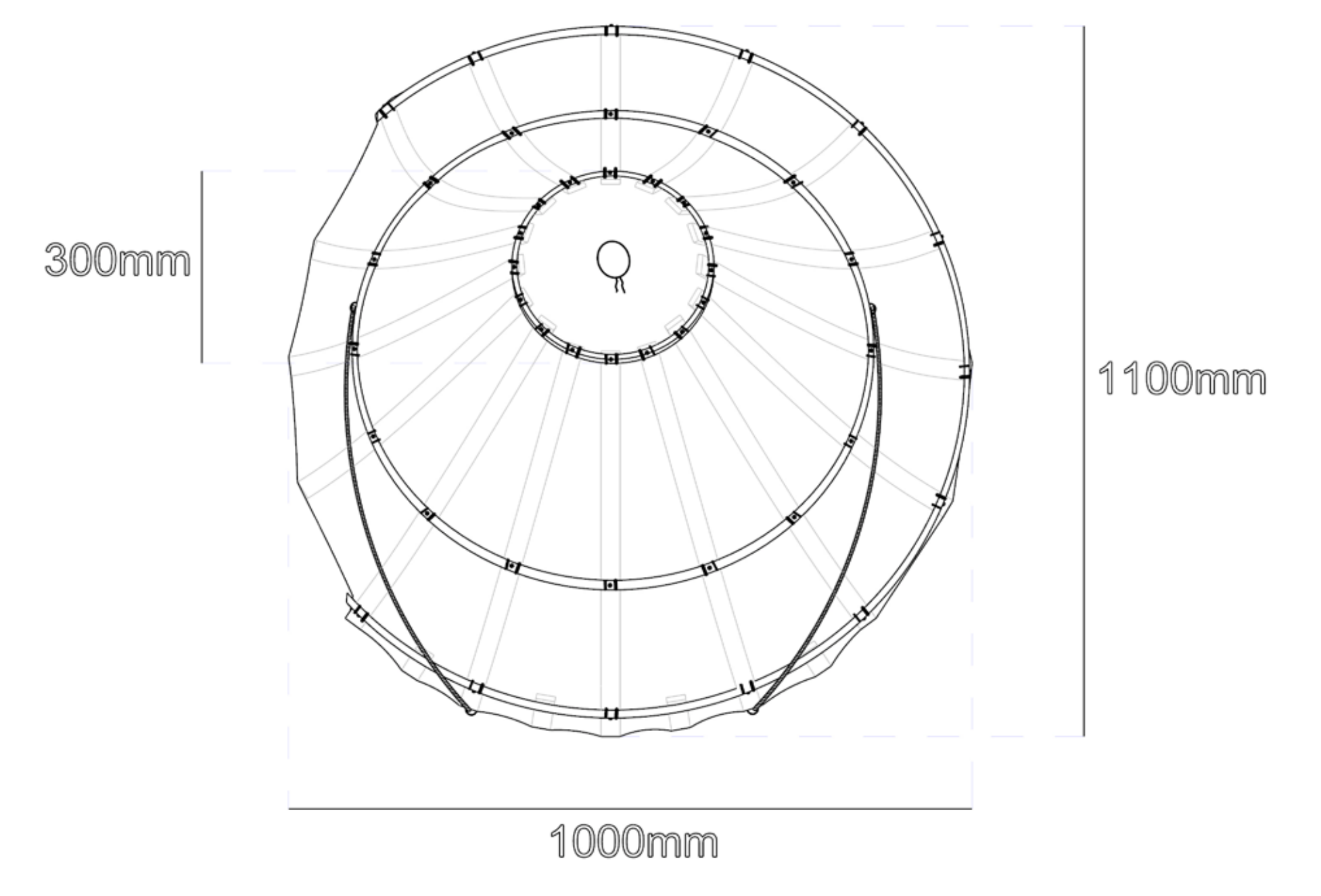
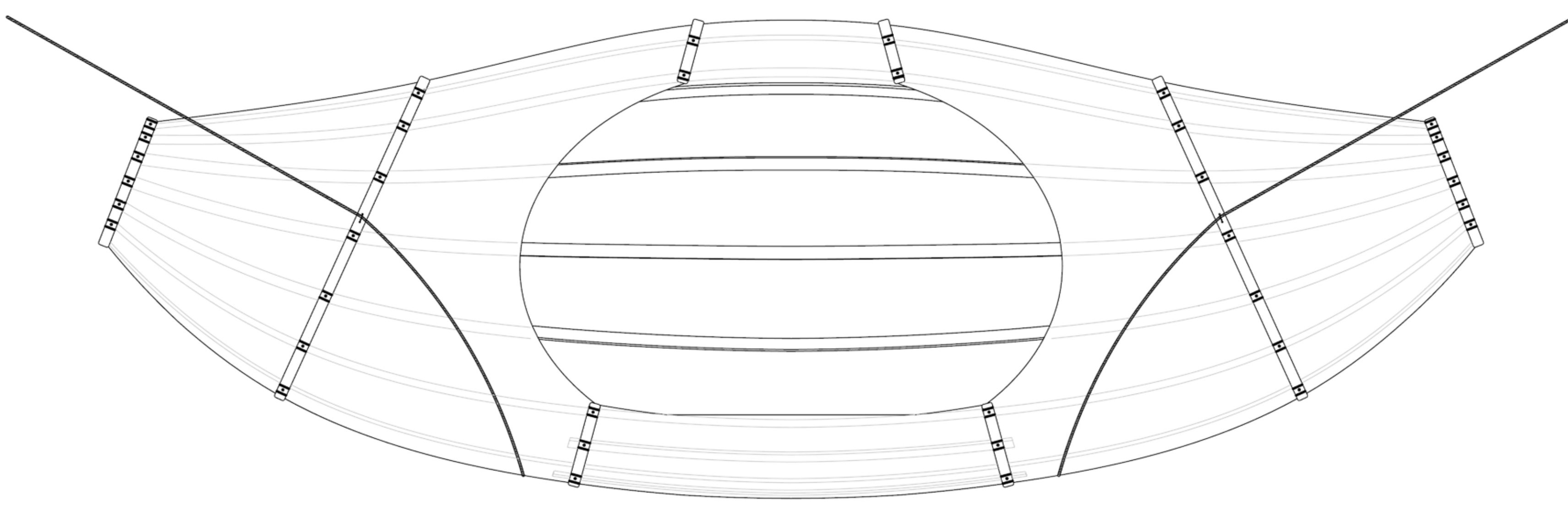
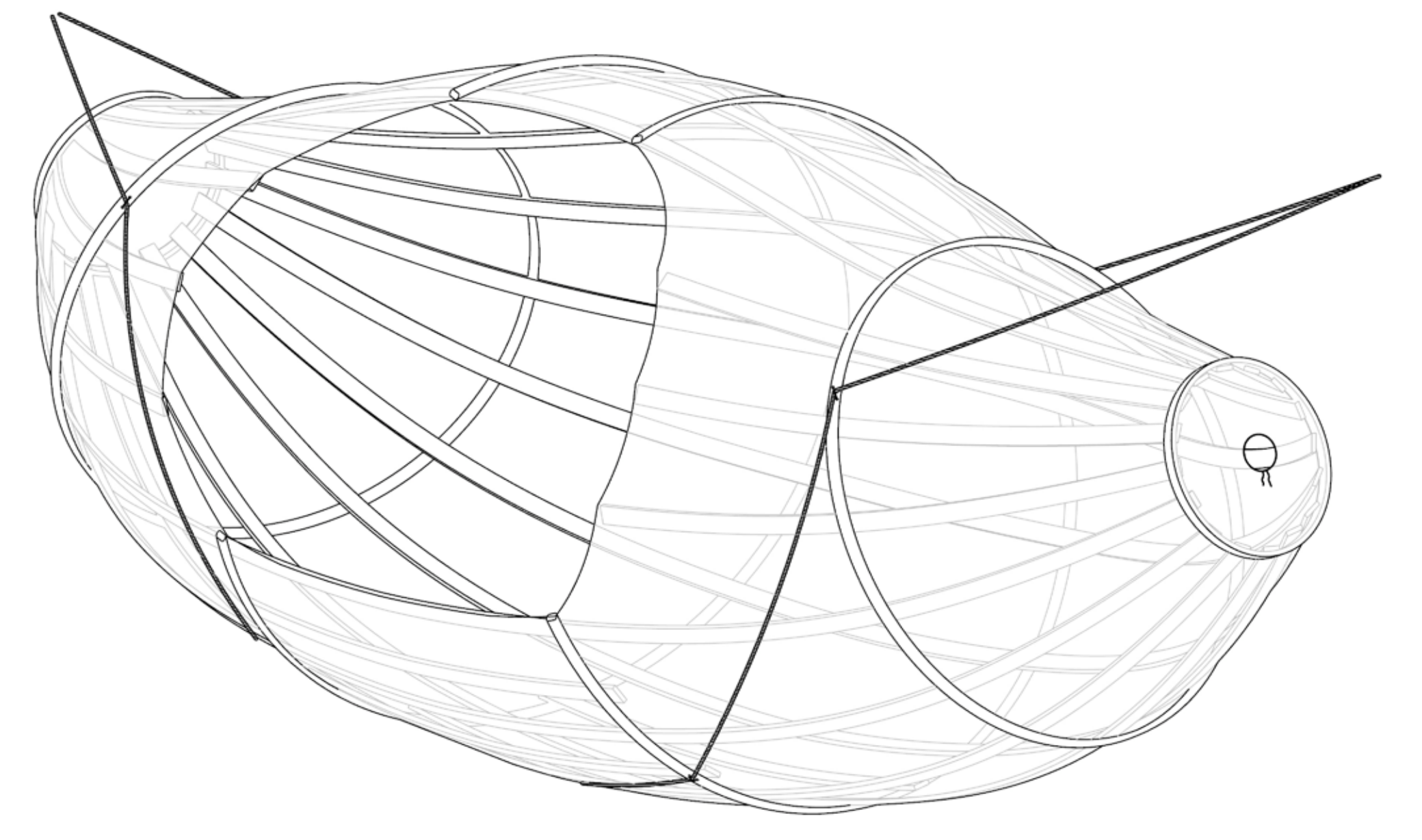
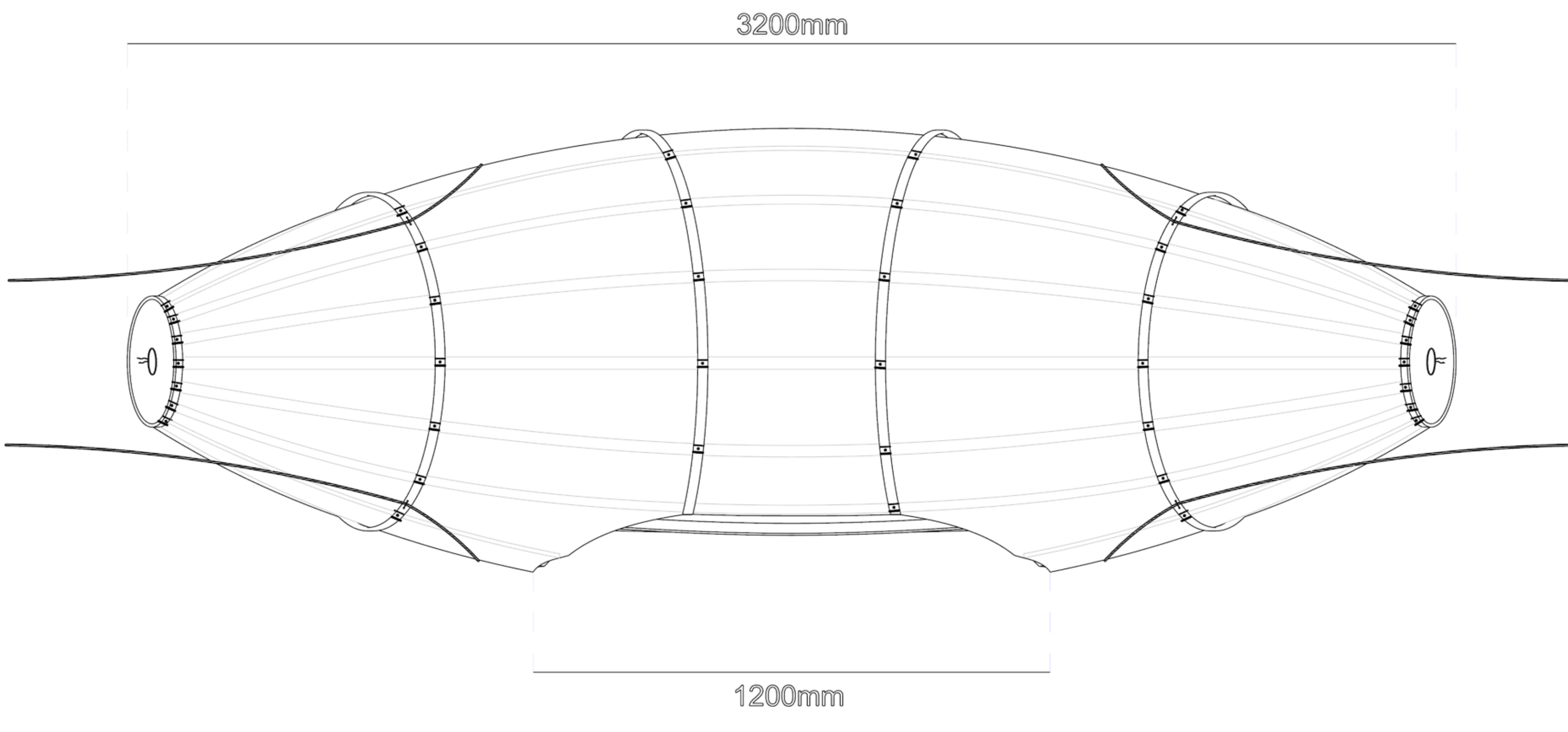

Scale 1:8

