



Arkitektur- og designhøgskolen i Oslo
The Oslo School of Architecture and Design

DIPLOMA PROGRAM FALL 2017

Diploma candidate: Ivana Mijic

Institute: Architecture

Main supervisor: Neven Fuchs-Mikac

Second supervisor: Andrea Pinochet

External supervisor:

Company cooperation:

Title of project:

Research Facility in The Botanical Garden of Oslo

INDEX

INTRODUCTION

THESIS

HISTORY

PROGRAM

SITE

SUBMISSION MATERIAL

REFERENCE PROJECTS

SOURCES

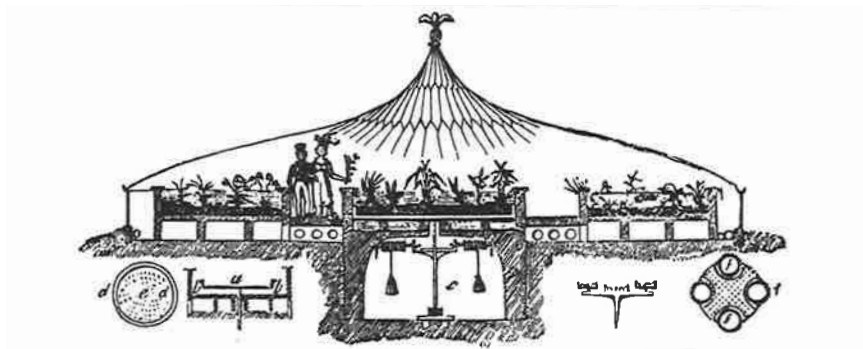

INTRODUCTION

The Botanical Garden in Oslo has a collection of more than 6.600 different plant species from around the world. A large part of these plants are endangered and preserved outside of their natural environment (ex situ). Some are placed in the existing greenhouses, Victoriahuset and Palmehuset, but most of the plants that need special care are placed in the working greenhouses where the research and preservation work is happening.

The research department is an important part of the garden in Oslo, but unfortunately the spaces today appear as temporary and neglected. The department is placed in the north side of the garden, where it is cut off from the rest of the infrastructure with fences and smaller buildings, the buildings are secluded even though there are daily activities between the research department and the rest of the garden.

THESIS

If we see the whole Botanical Garden as a 15 hectare large research field, the house for the plants should have a stronger presence and visibility in the garden. This diploma is introducing a new building for research that is representative for the scientific work performed in the garden. The aim is to transform the north side of the garden so that it works better as a city park and as a working space for the research department. By rethinking this area I am seeking to complete the existing garden and to include the research department as an important part of the story.

Project title:

RESEARCH FACILITY IN THE BOTANICAL GARDEN OF OSLO

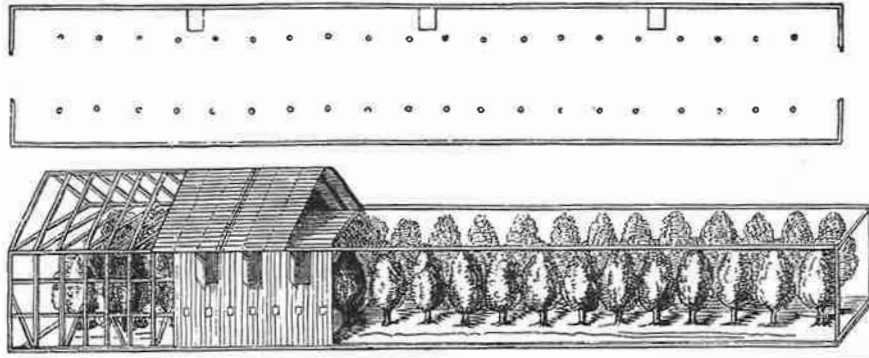

HISTORY

The concept of a greenhouse is an environmentally controlled area where plants can grow regardless of the climate in that specific country. The typology dates all the way back to the Roman empire where vegetables were grown in controlled areas so that the food would be available for the emperors whenever they desired it. The Romans were also aware of the medicinal properties of plants, and used this knowledge in developing medical products. In 13th century Italy a different kind of greenhouse started to occur, it was a house for the exotic plants that the explorers brought back from the tropics, they named it Giardini Botanici (Botanical Garden). By the end of the seventeenth century the botanic search was on. Wealthy private collectors and institutions financed plant and seed hunting expeditions round the world, it was the beginning of the international trade. The rapid expansion of the plant collections required better performance from the stoves, pits and greenhouses to cope with the new climate demands. The Dutch experimented with greenhouses that resembled an environmental machine producing plants. Early on they used heat storing materials such as bricks in walls and floors, solid back walls, double-casement windows and large sloped glass facades towards the south, as well as many different hot and cold air distribution systems. With time there has been many experimentations with the typology as the technology of glass and steel evolved. The development was great in England during the 19th century, big structures like Kew Gardens and the Crystal Palace in London were constructed and showed a great sophistication in technological progress of the country.

Today the Botanical gardens are cultural and scientific organisations that have a strong connection to the public, it provides information about the environment, issues about conservation and sustainability. In the last 30 years botanic gardens have seen a revival as scientific institutions due to the emergence of the conservation of plants worldwide. Studies show that around 43% of endangered plants are cultivated and preserved in botanical gardens around the world. Their importance is growing due to the existing collections and the scientific knowledge they possess in the propagation of plant species.

PROGRAMME

The program offers new workspaces for botanists and scientists that work in the garden today, and a visitor center where people can seek knowledge about the research work being done in the garden.

The project consists of the following spaces:

foaje
wardrobe
toilets
auditorium
library
reading area

greenhouses with five climate zones for research;

Mediterranean
Arctic
Rainforest
Cloud forest
Desert

wardrobe for scientists and botanists
work spaces
offices and lab areas
kitchen and eating area for staff
storage

SITE

UNIVERSITY BOTANICAL GARDEN

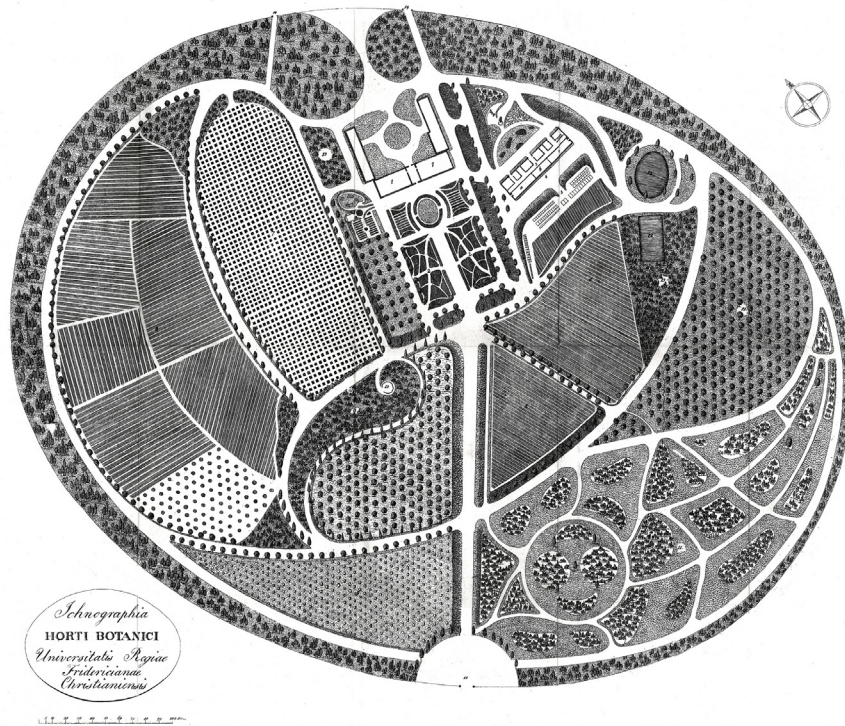

Map of the garden, 1825.

The University's Botanical Garden is situated in Oslo east in the neighborhood Tøyen. The first building was established in 1679, a noble garden called Tøyen hovedgaard. The property had many owners between 1679-1813 before it was donated to the University after the country became independent in 1814. The Botanical garden was established and is still administrated by the University of Oslo today. One of the main objectives of the garden was to map out the natural resources of the country. Minerals, animals and plants were collected so that the country could become self-sufficient. Botany became an important field of work in strengthening the country's horticulture and in finding new crops. The garden today is around 15 hectar and serves the purpose of research, education and as a city park. The garden consists of five museum buildings, a few other smaller administrative buildings, a research department and Tøyen Hovedgaard.



1879

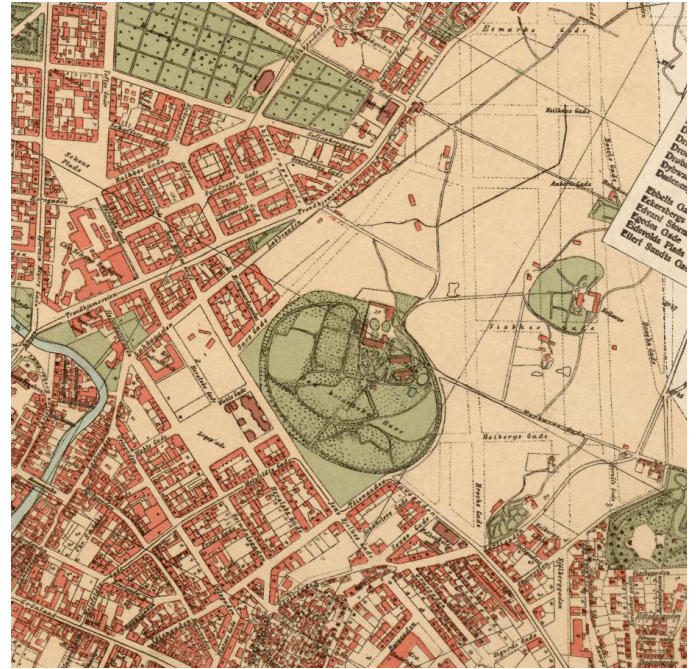

1901



1938



2017

THE GARDEN TODAY, LOCATION OF THE BUILDINGS AND ENTRANCES

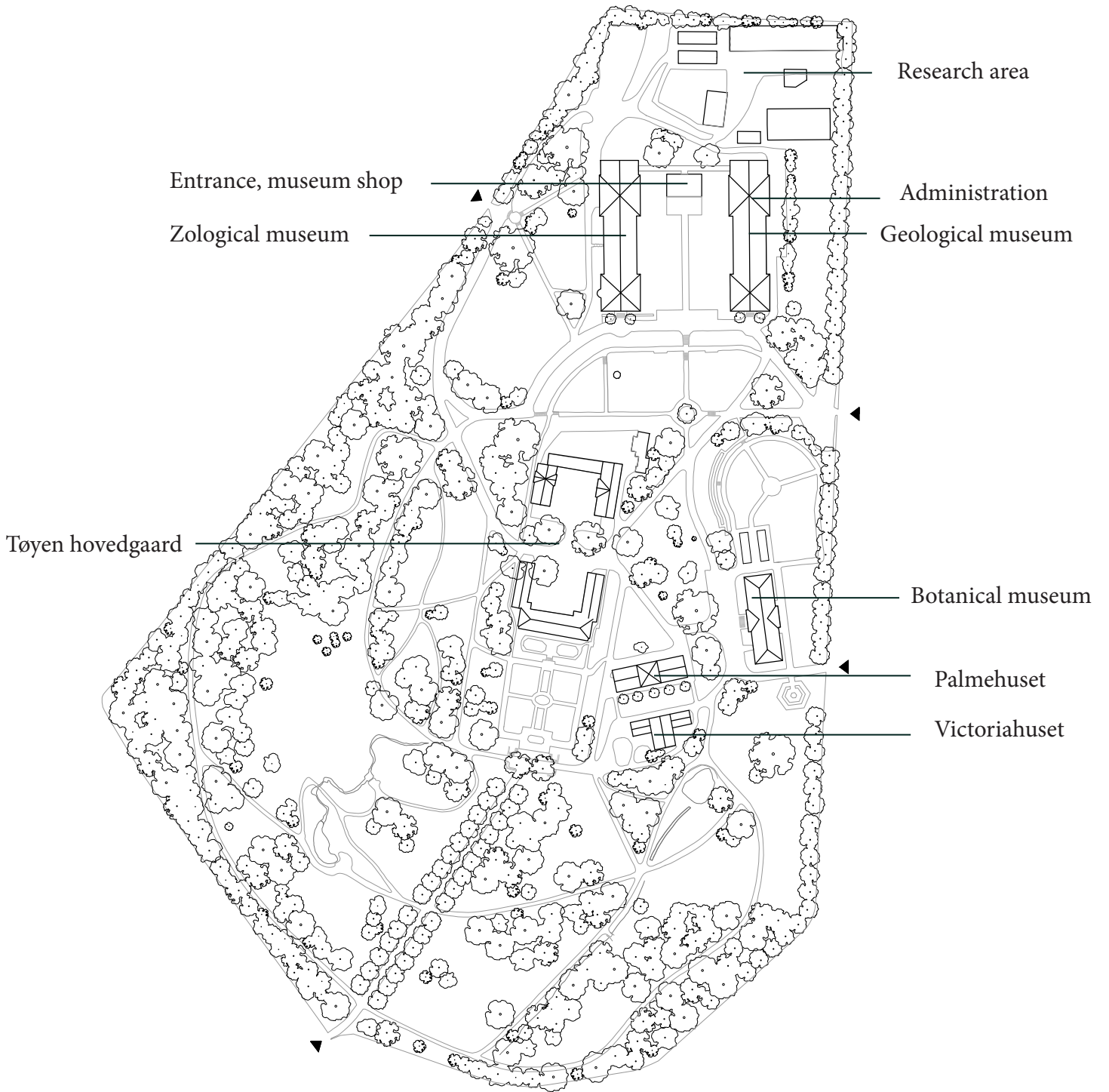

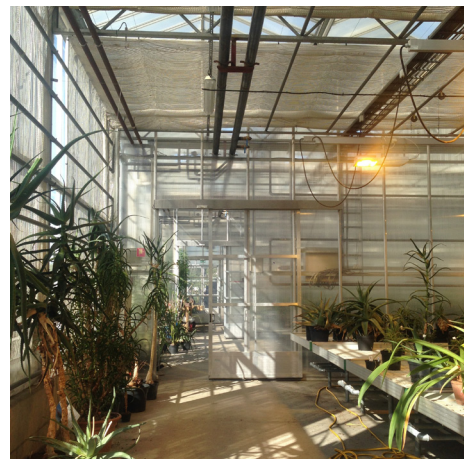

Pictures from the existing research department and area around.

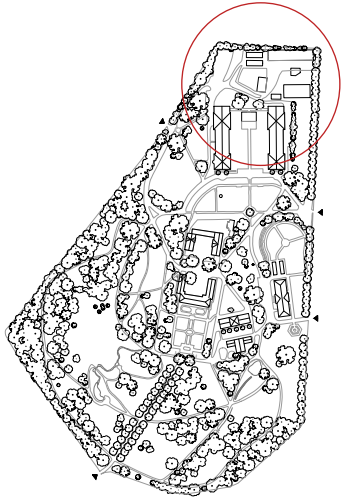

AREA IN FOCUS

SUBMISSION MATERIAL

DRAWINGS

situation plan 1:1000

situationplan 1:500

plan 1:100

sections 1:100

detail section 1:50

MODELS

situation model 1:750

situation model 1:1500

presentation models 1:50

model photos

ILLUSTRATIONS

TEXT

DIAGRAMS

PROJECT BOOK

REFERENCE PROJECTS

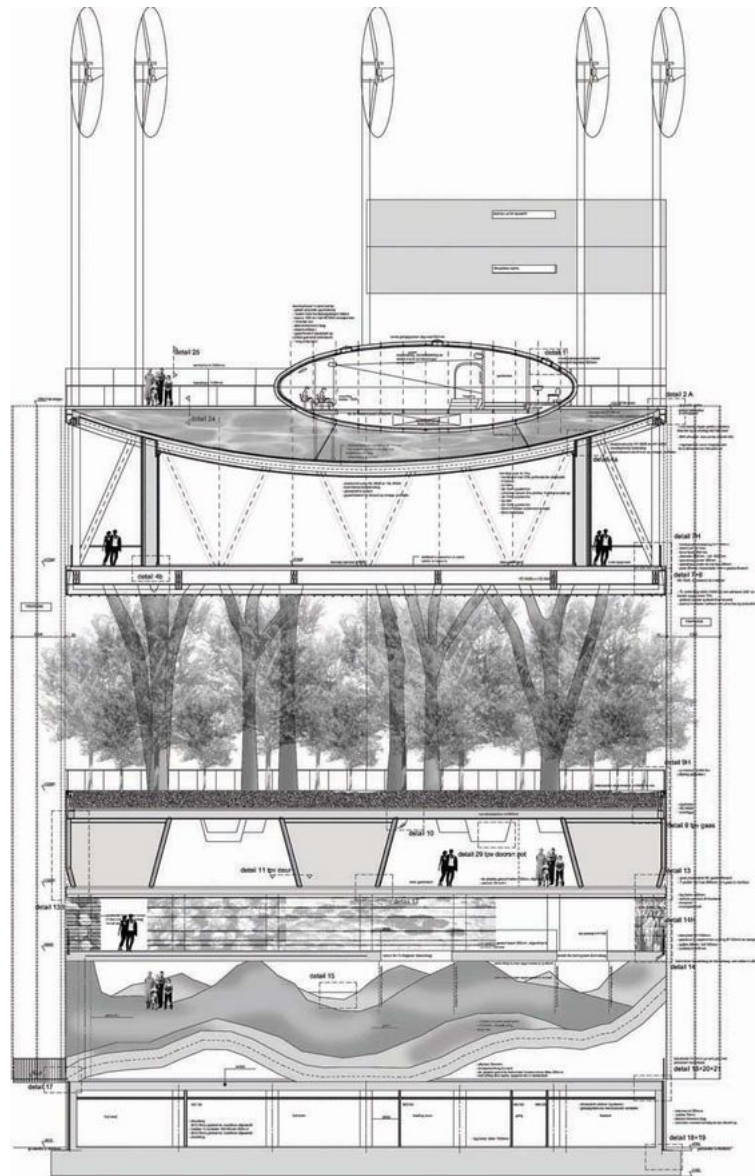

EXPO 2000, HANNOVER
MVRDV

Nature arranged on many levels provides both an extension to existing nature and a symbol of its artificiality. It provides multi-level public spaces that represents different kind of natures.

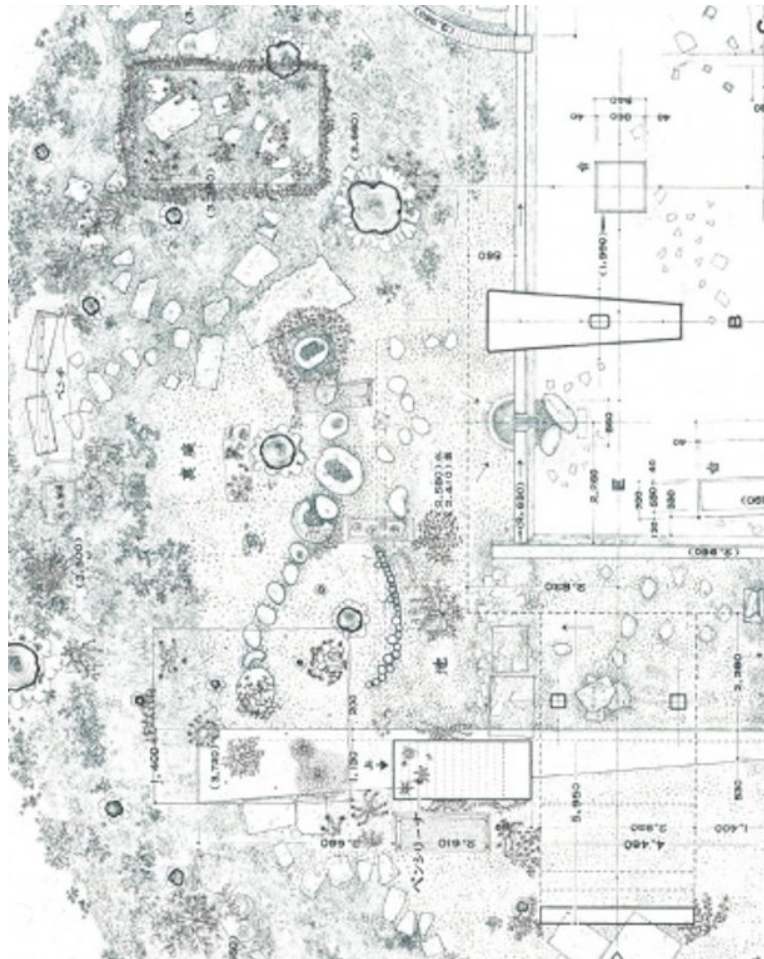

VENICE BIENNALE 2008
junya Ishigami

This project does not seek to dramatically alter the environment but to affect it ever so slightly by installing lightweight works of architecture. In doing so, the existing vegetation could be enriched to create diversified landscape, producing something that would expand the existing environment.

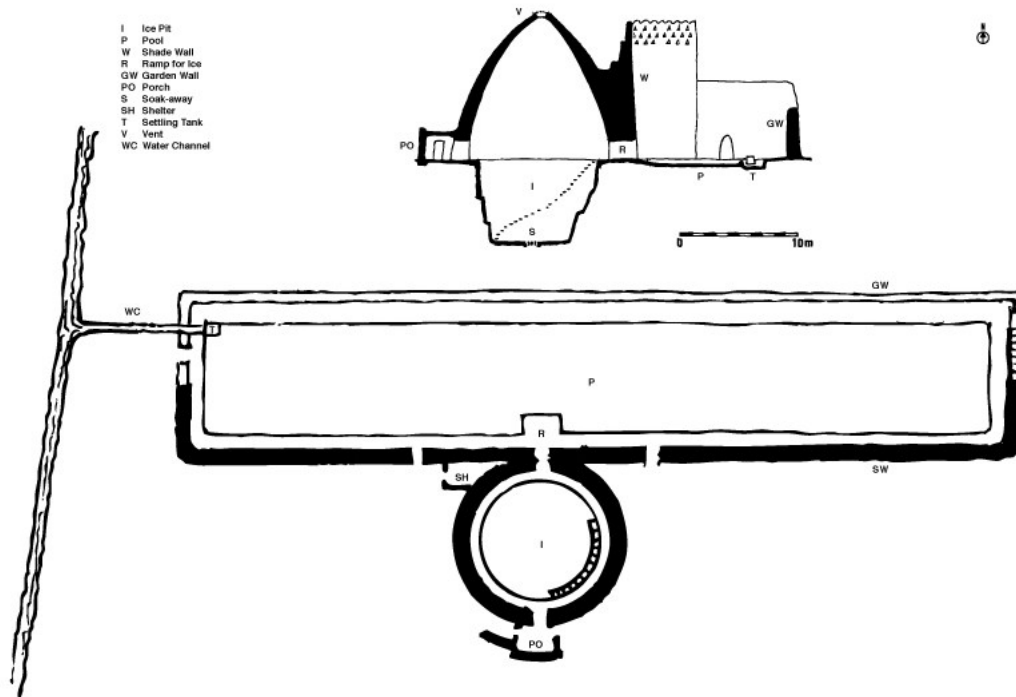

YAKHCHÁL

Persian ice house

The house is made to store ice that were created with special techniquet in the desert. It is a large subterrenean storage space that manages to keep a cool temperature by it's connection to a water system (Qanat) that brings cool air and maintains a stable temperature with the help from the sorrounding earth.

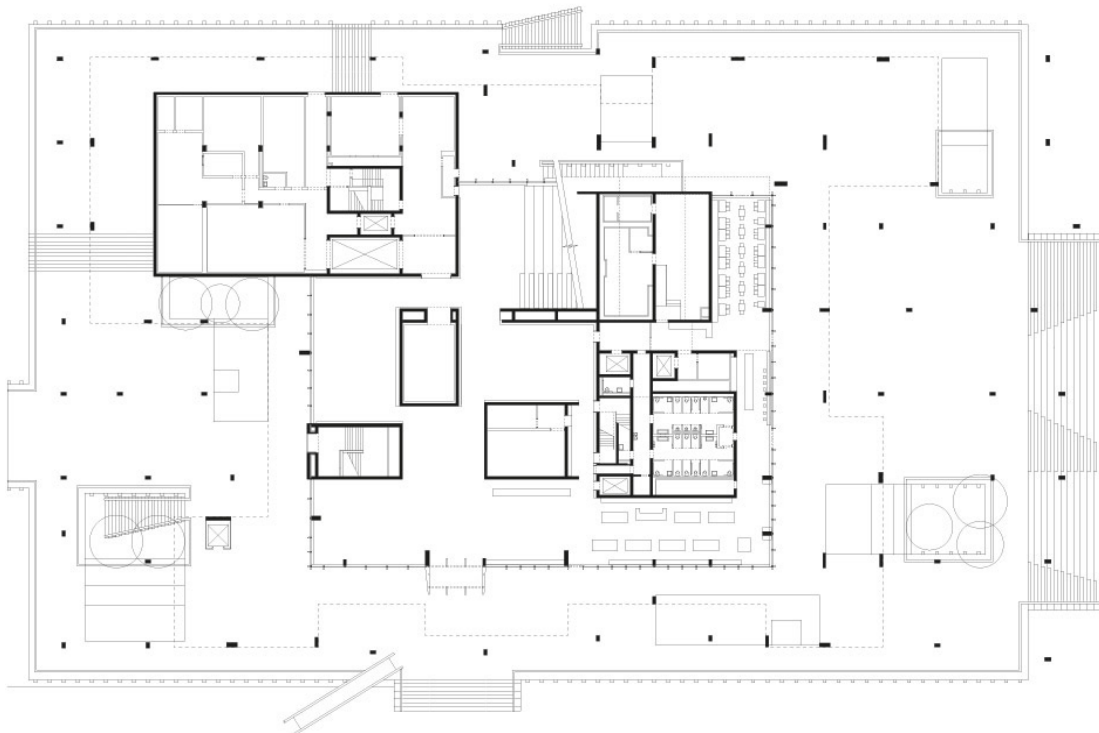
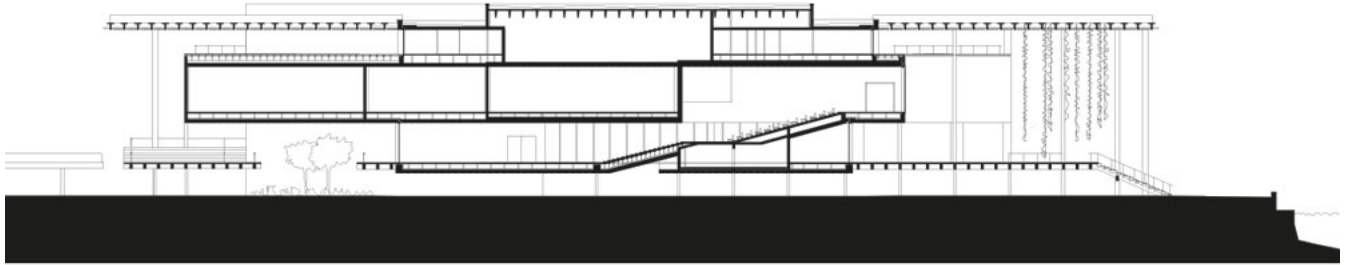

THE PEREZ ART MUSEUM
Herzog & De Meuron

The project creates an intermediate environment. It is a gradual transition between the hot and humid outside, and the cool and controlled inside. Smaller micro climates are raised from the ground with columns in different dimensions.

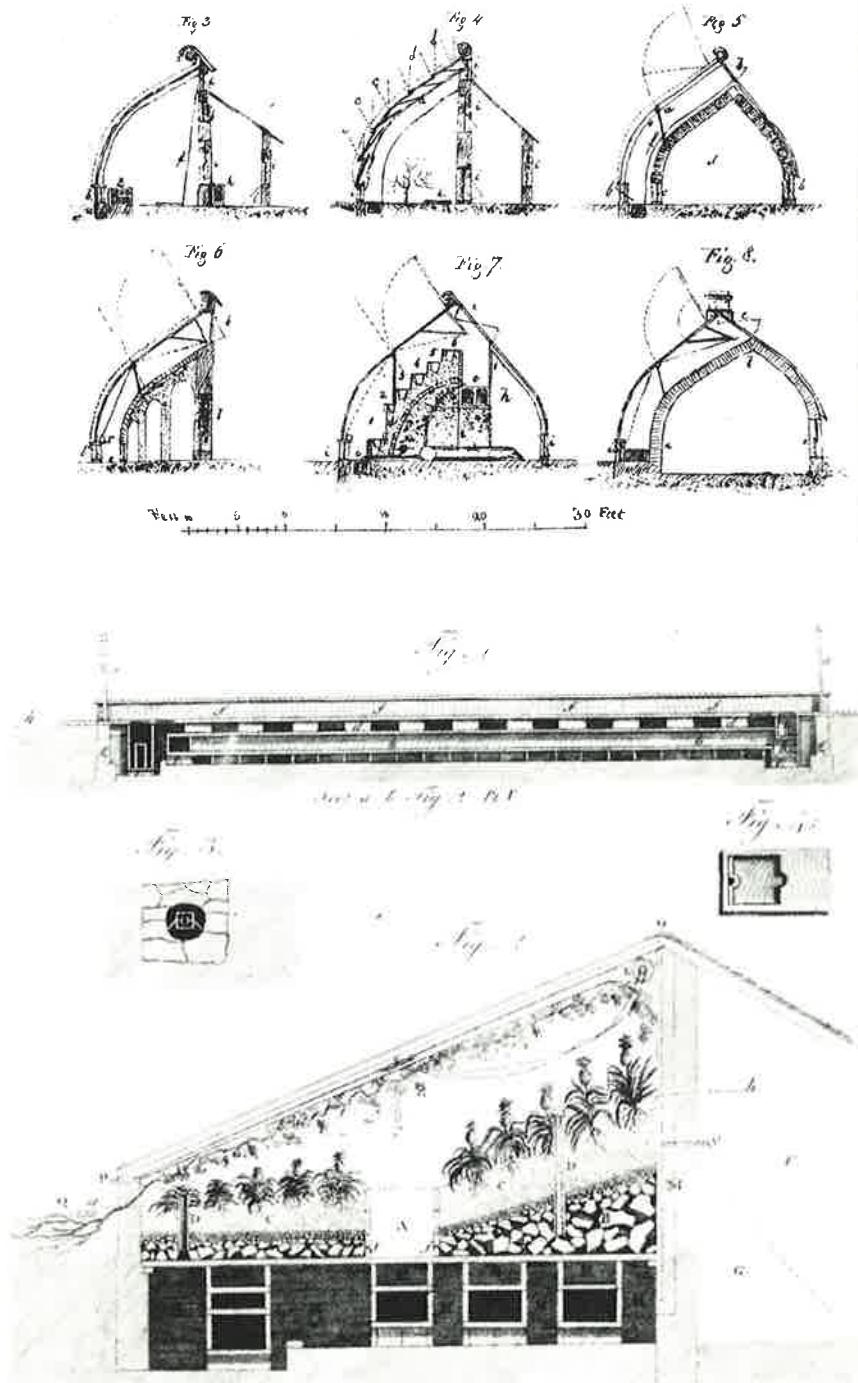

DUTCH GREENHOUSES

The Dutch experimented with greenhouses that resembled environmental machines producing plants. The typology was determined by the conflict between form and function, considering the plant culture as the main function that architecture was shaped around.

SOURCES

WEBSITES

<https://www.bgci.org/resources/history>

<https://www.iucn.org>

BOOKS

Charles McIntosh. The book of the garden.

John Hix. The glass house