

Galleri Oslo - A Project for a new Public Interior

Can leveraging the identity of public buildings challenge urban planning ideology to return it to the fold of the public domain?

In *The Public Interior as Idea and Project* (2016), Mark Pimlott defines a public interior as that space which architecture makes, which is all at once set apart from the world and in its midst... The interior, regardless of its scale, whether it is that of a dwelling, a temple, a settlement, a city or a continental territory, is informed and shaped by ideas.

By ascribing to the public interior a set of values and ideals, it adopts a political position and be understood as an ideological endeavour to propose an alternative.

In this regard, my project for Galleri Oslo proposes an alternative to the existing context.

On one hand, to what is by far the most predominant form of public interior in our cities today, which is the profit-based and often privatised pseudo-public interior meant for consumption, that we know from our shopping malls and theme parks, to our train stations and airports; and which, coincidentally, is also a prominent

feature of Galleri Oslo, whose shopping arcade runs along the entire length of the building.

On the other hand it challenges the institutionalised belief in public programs of high culture as an urban planning strategy to attract and to cater for the upper-middle classes. This, to a large extent, fails to recognize the gap in social and economical capital amongst citizens, affecting neighbourhoods like Granland, in particular.

Finally, the case for the preservation of the building itself adopts a position contrary to present plans for its demolition, which is underpinned by a largely deregulated, market-driven urban planning strategy.

Thus, in proposing a new public interior for the city, my project seeks to strengthen and to sustain a viable public realm and, secondly, by knowledge of its local context, it seeks to address the notions of place and identity as critical objectives.

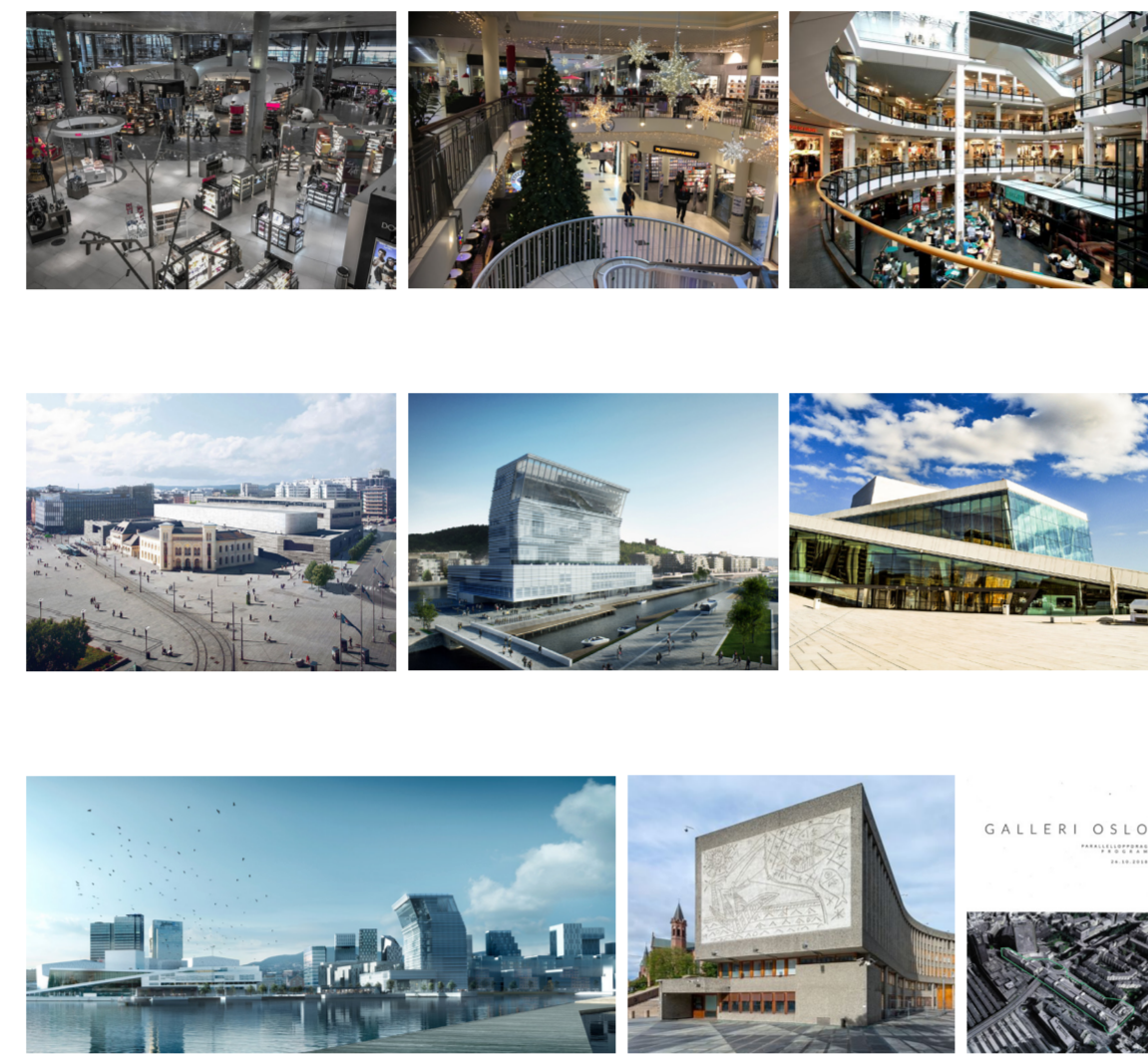

Site

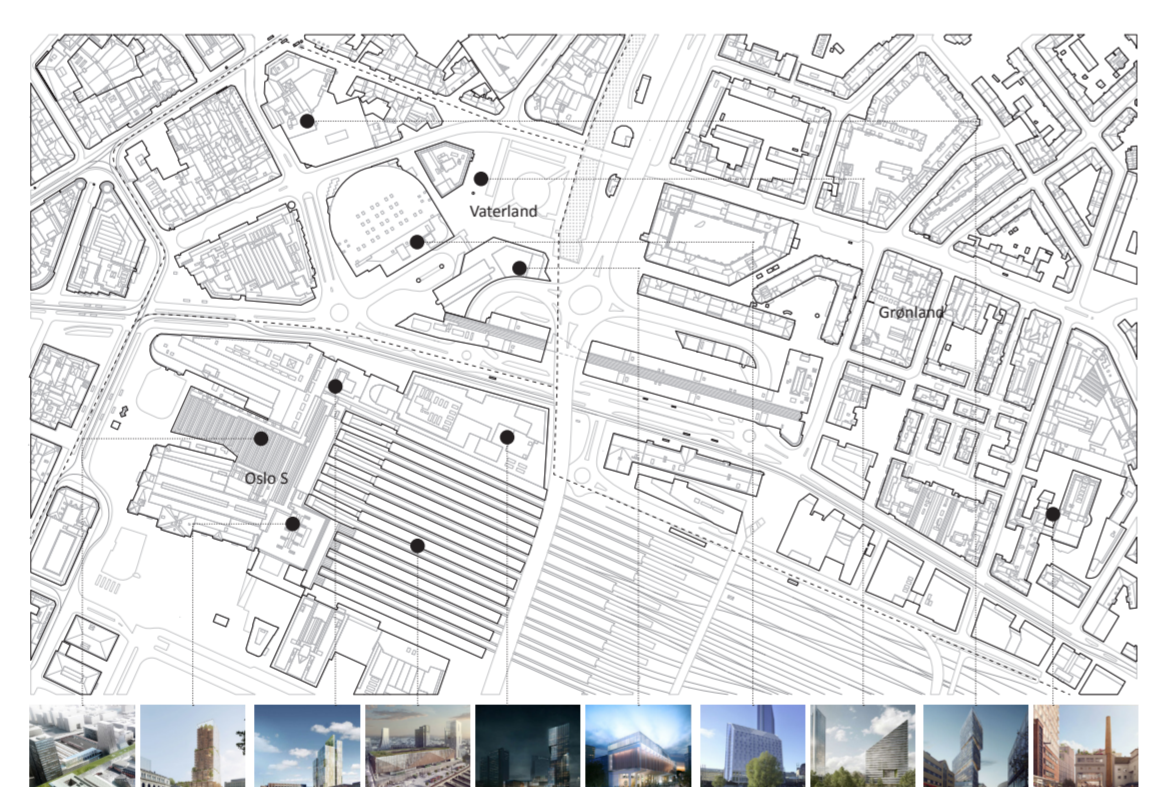
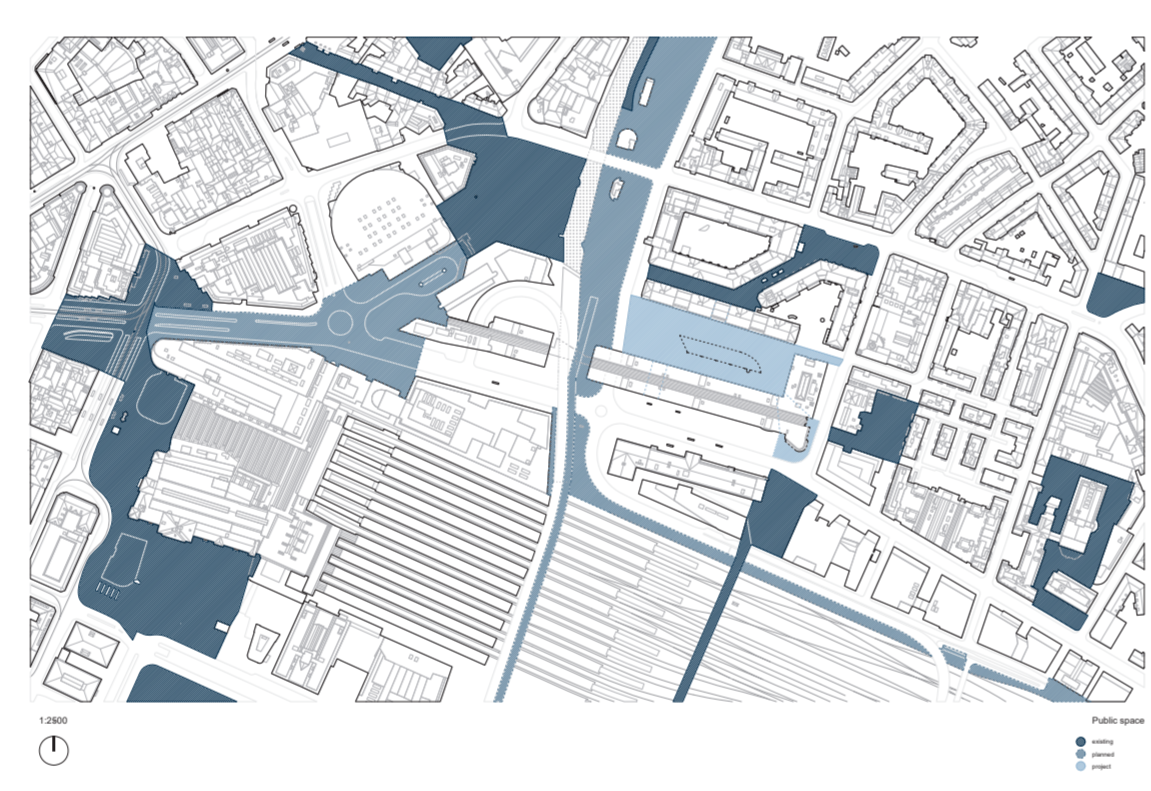
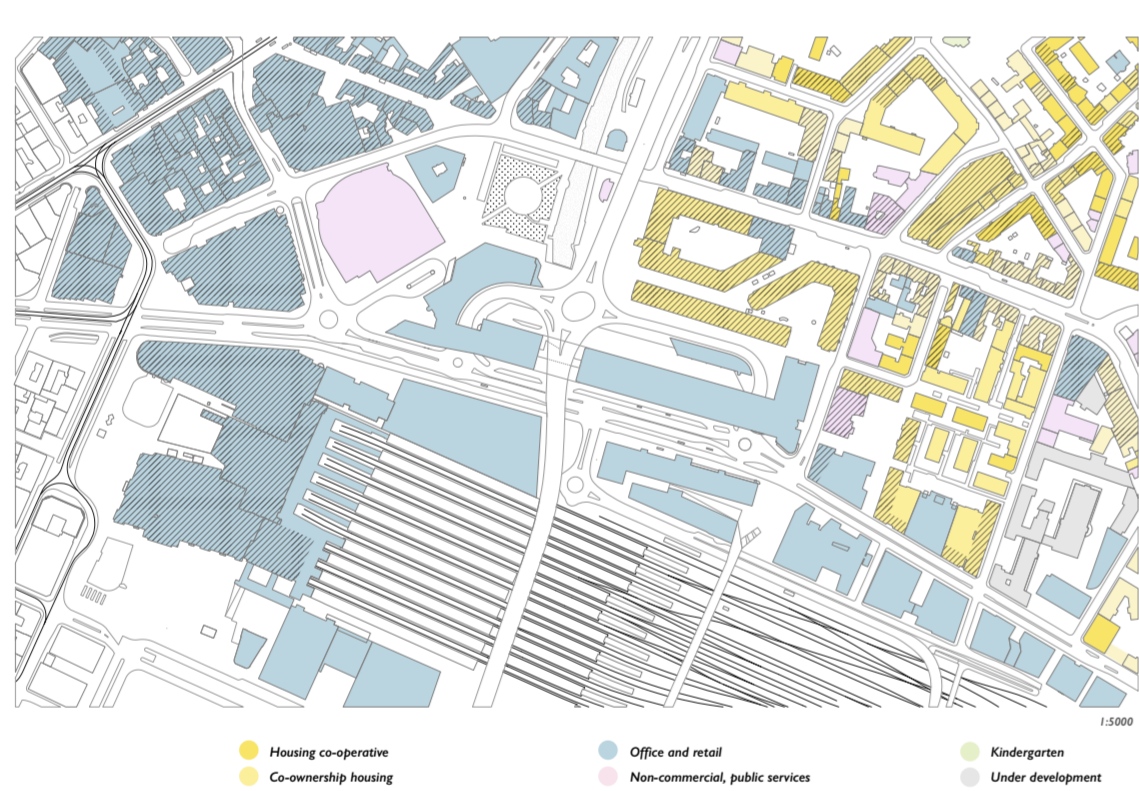

Galleri Oslo - project description

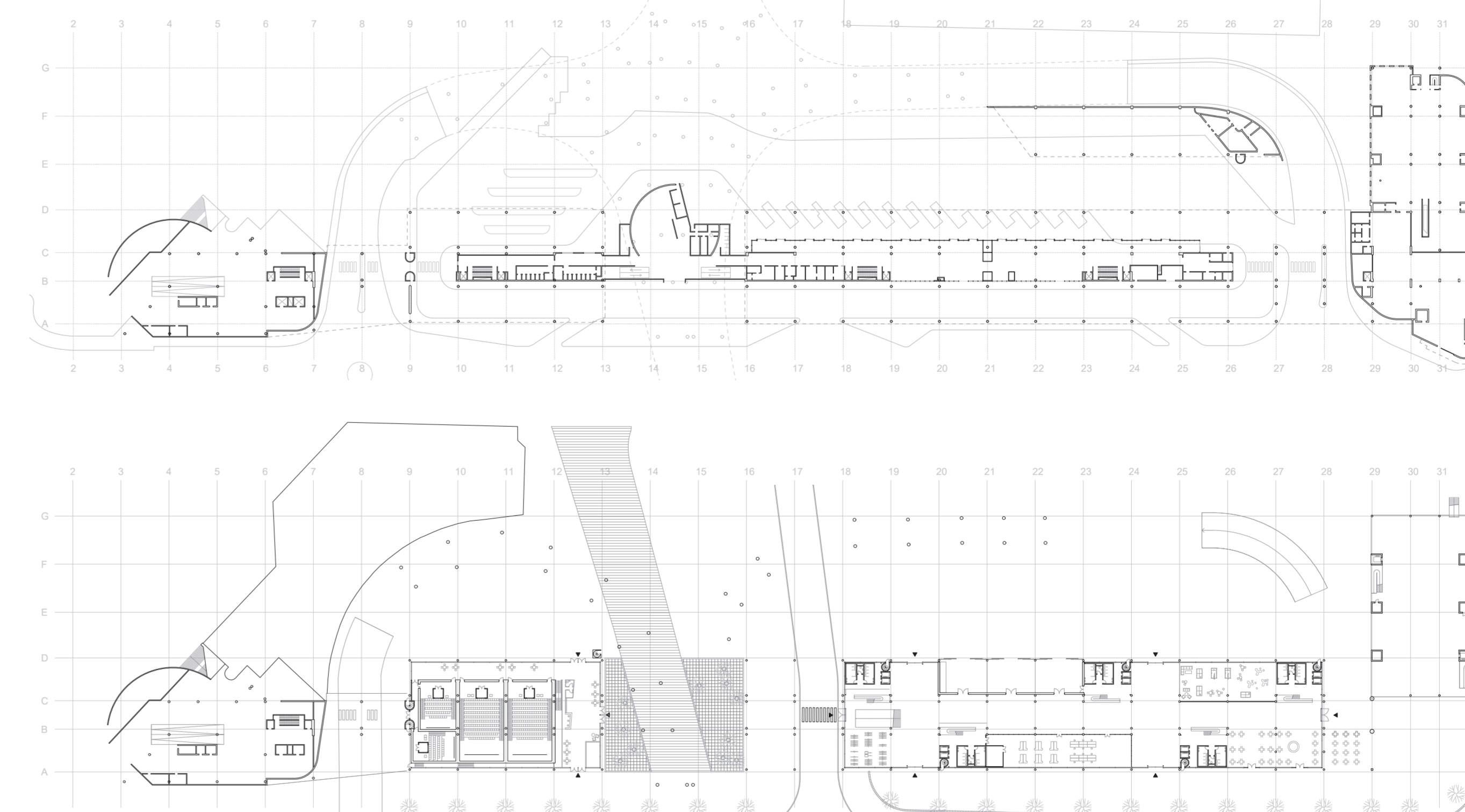
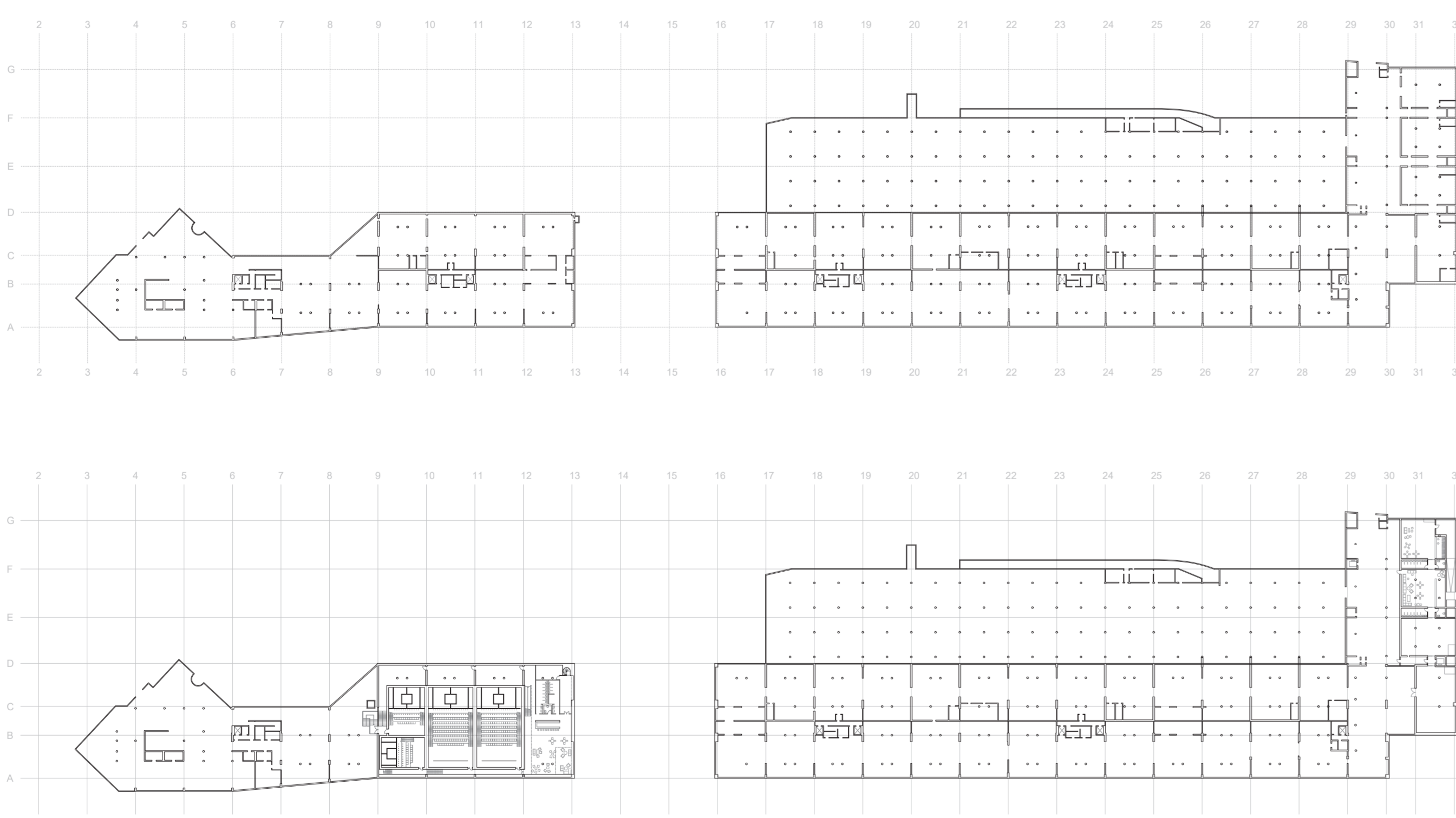
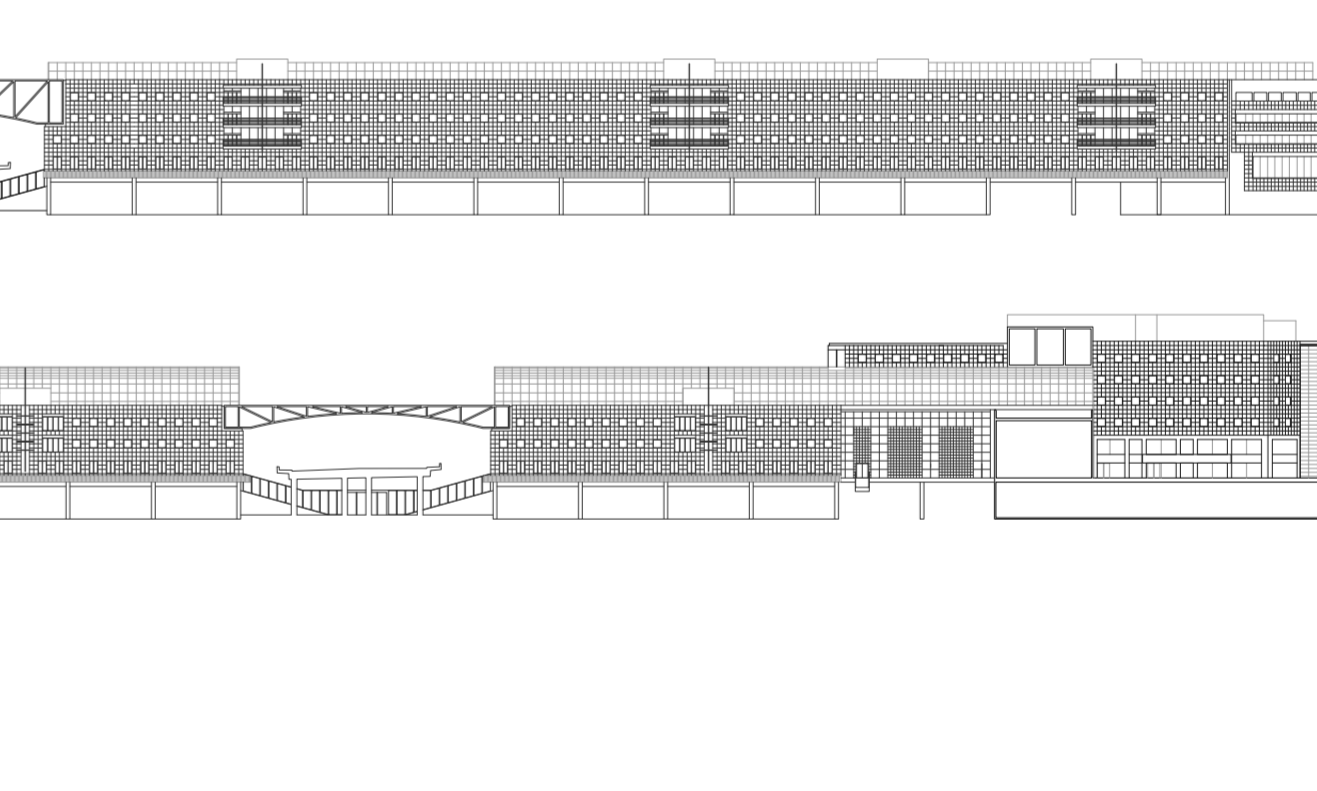
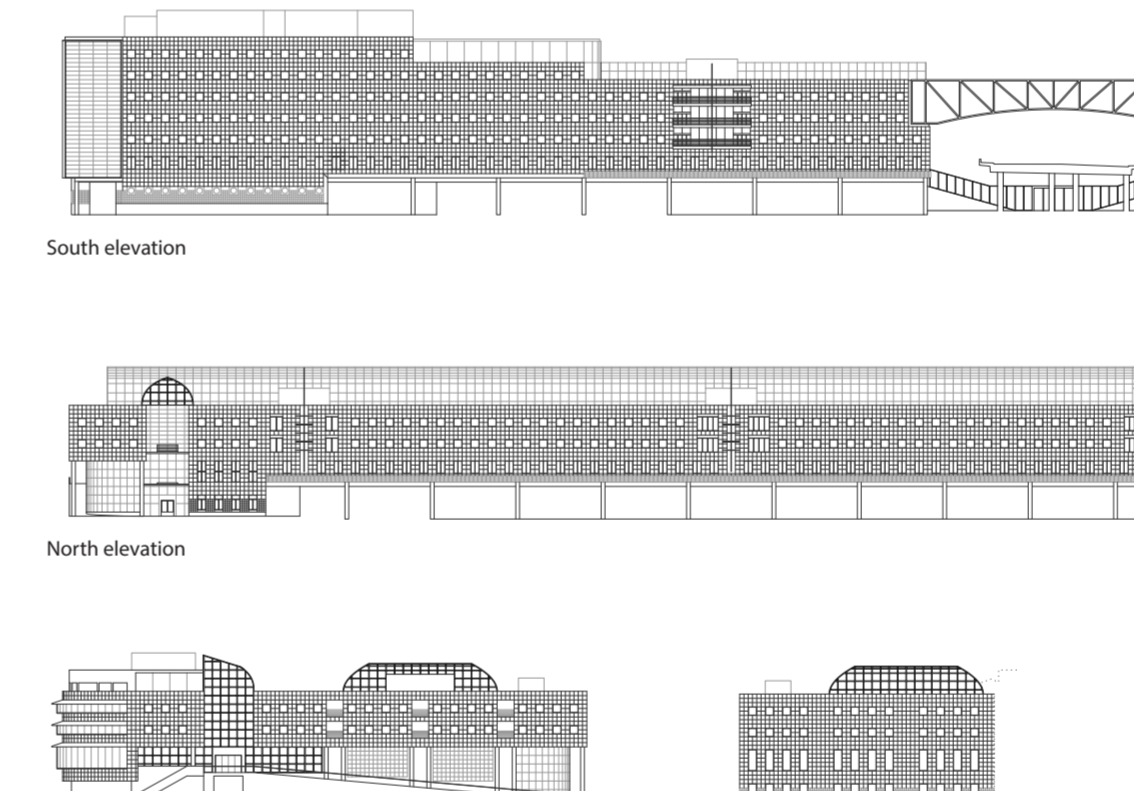
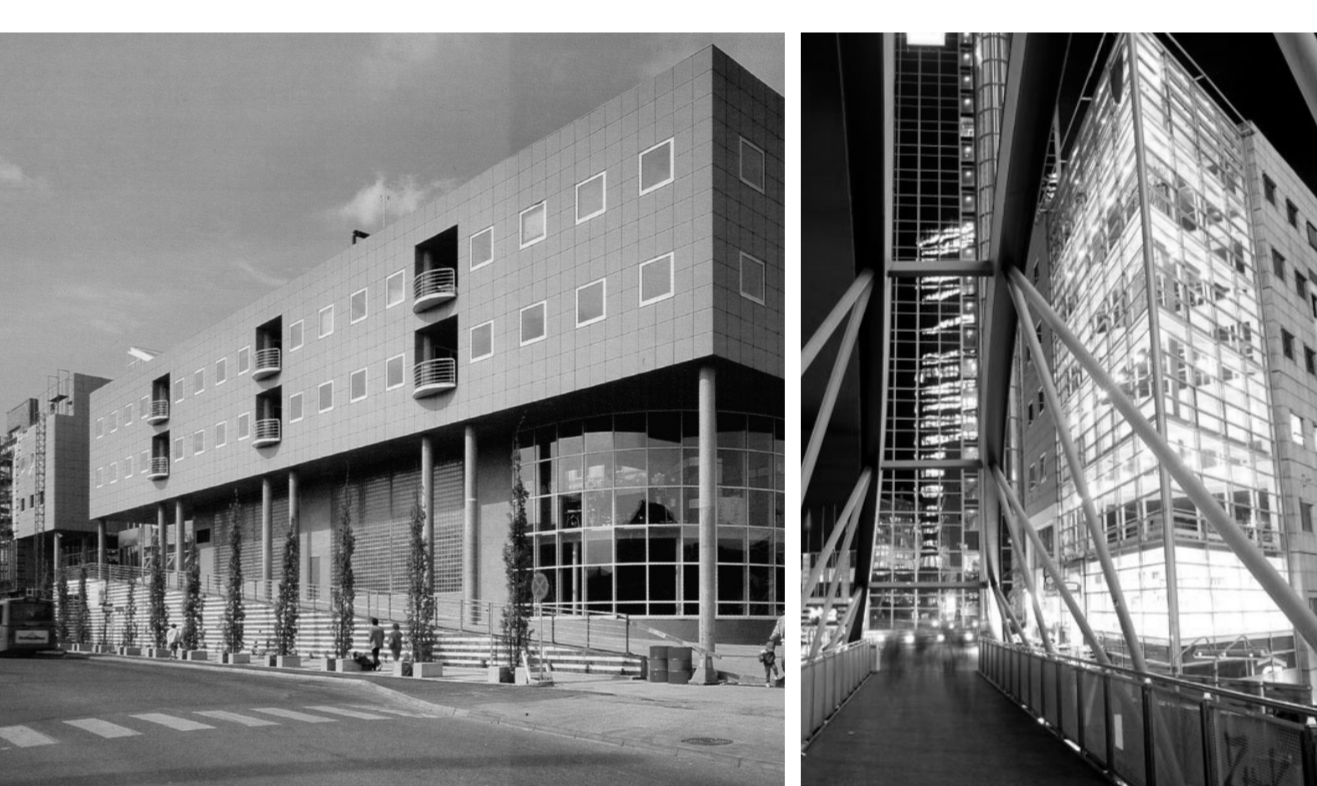
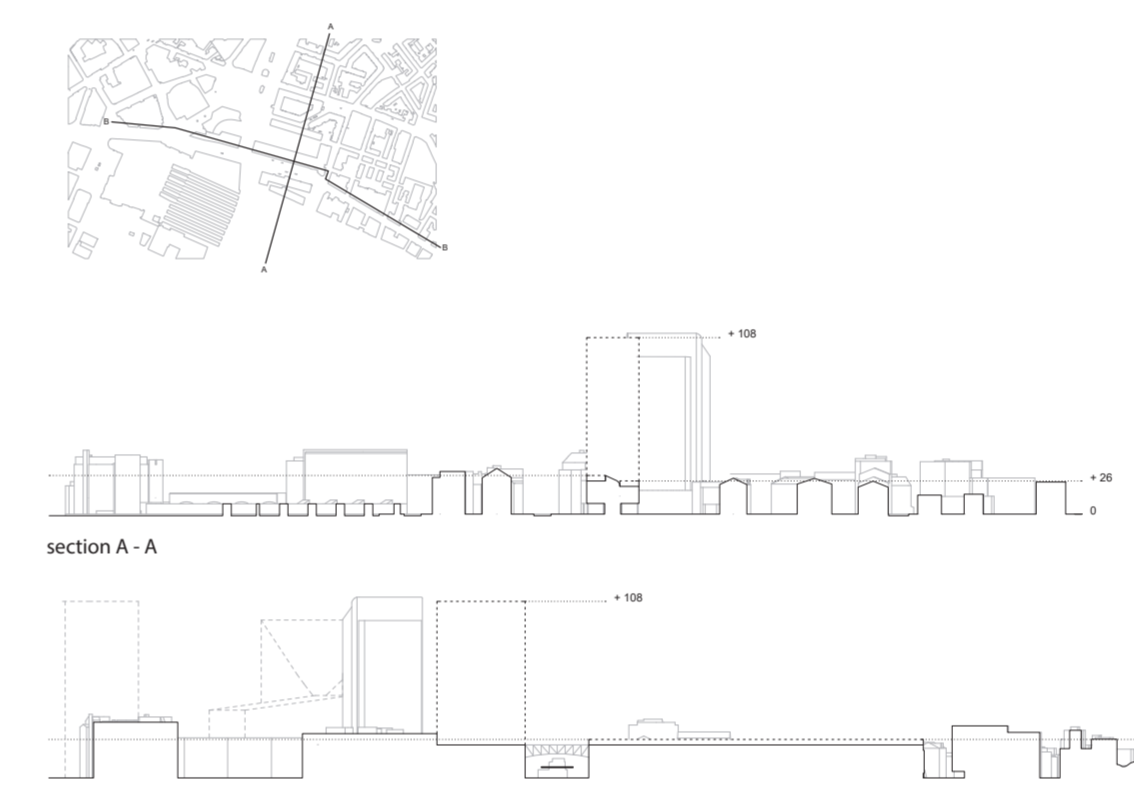
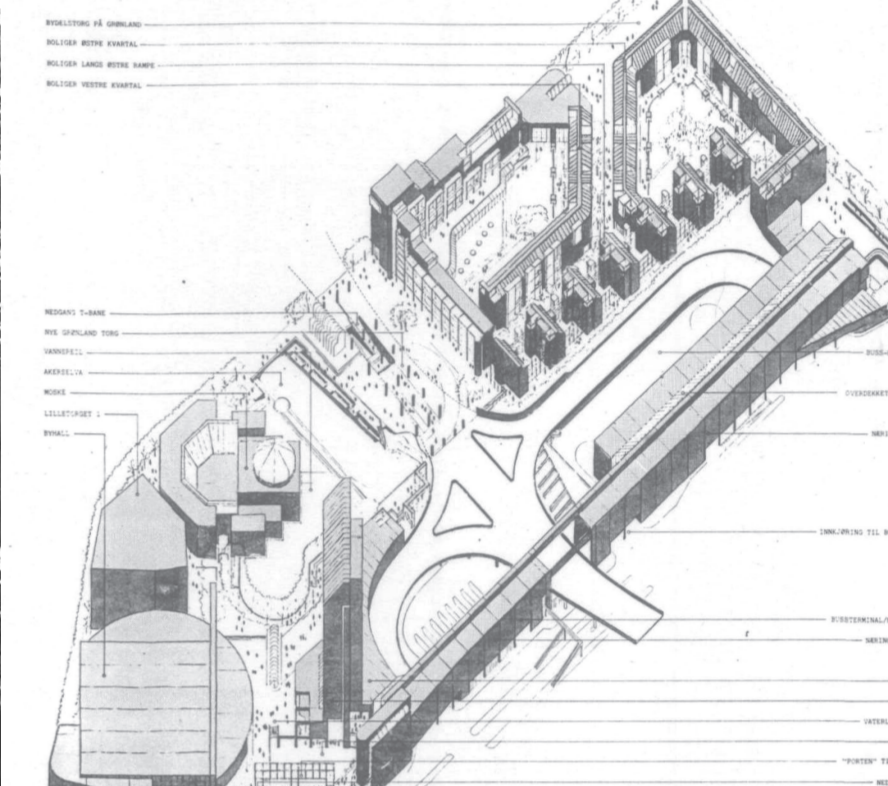

The "city wall"



Structural system

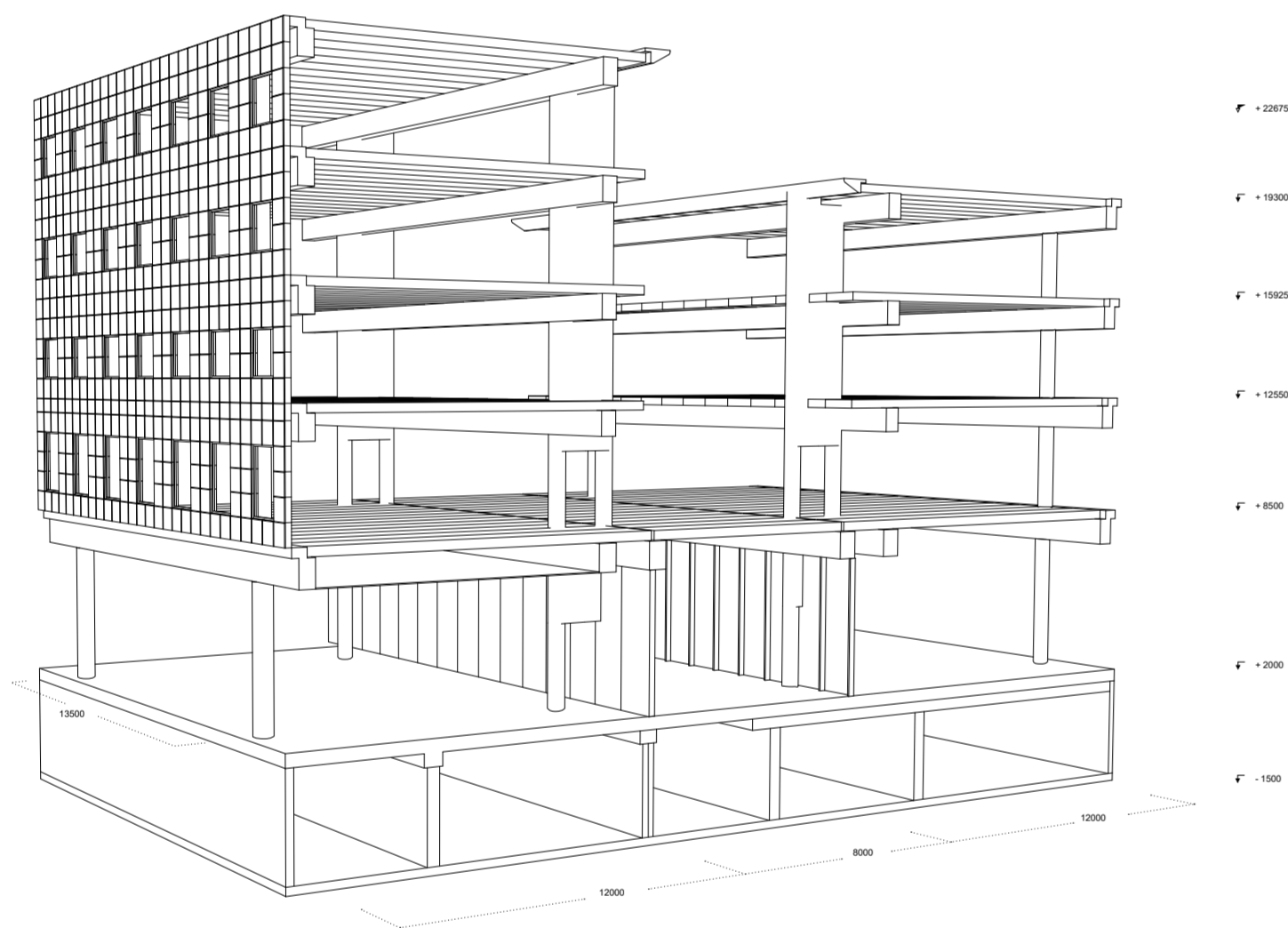
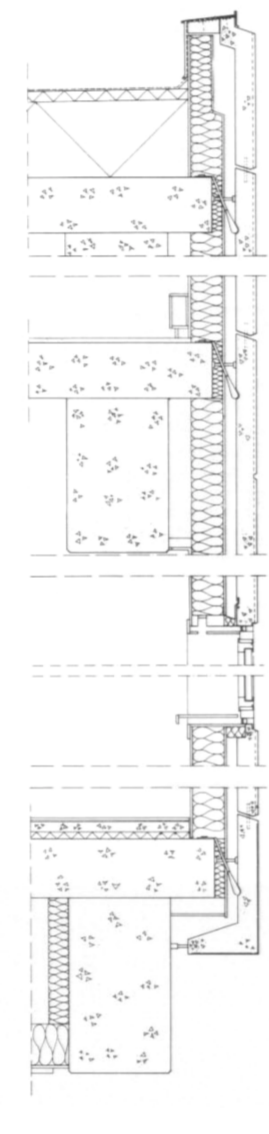

half section

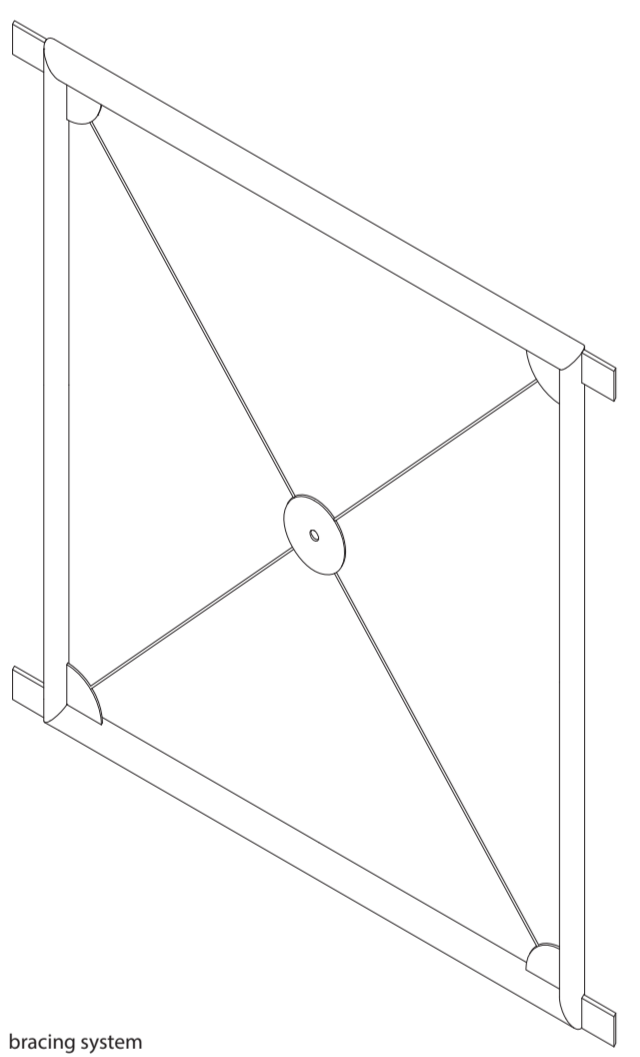

truss system

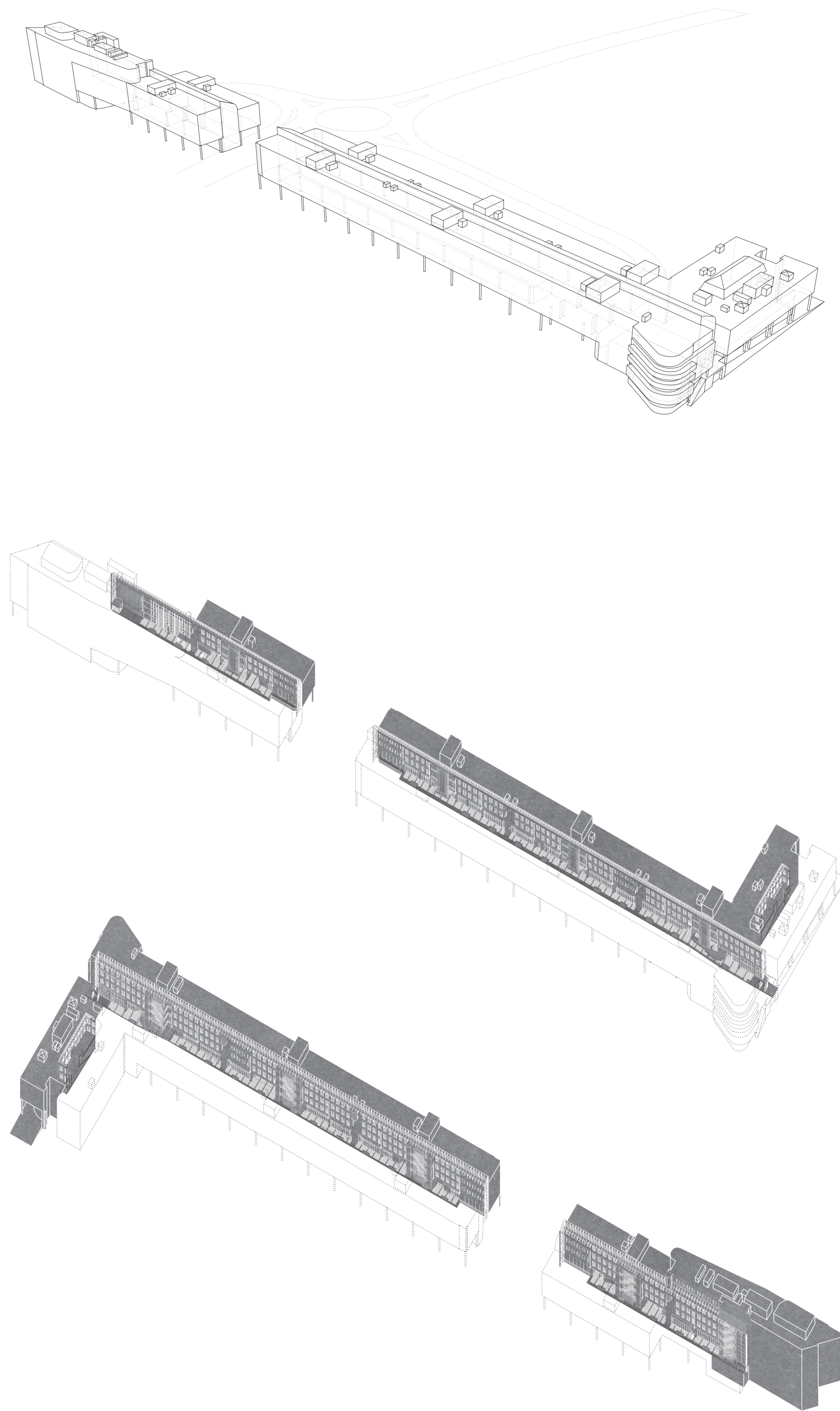

full floor public space

Circulation

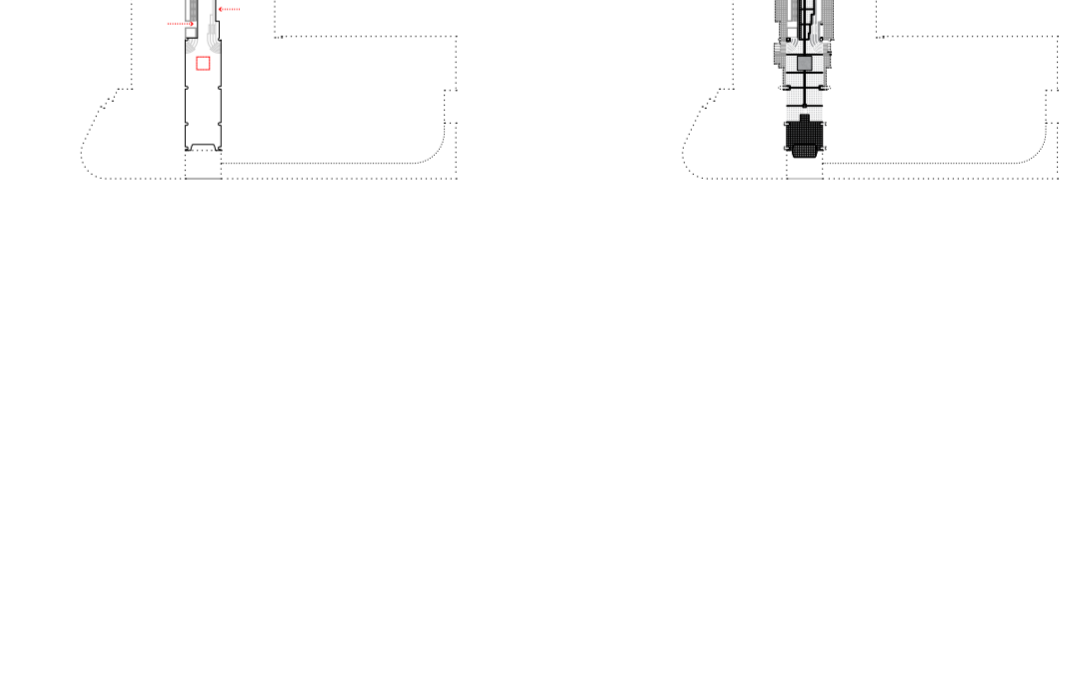
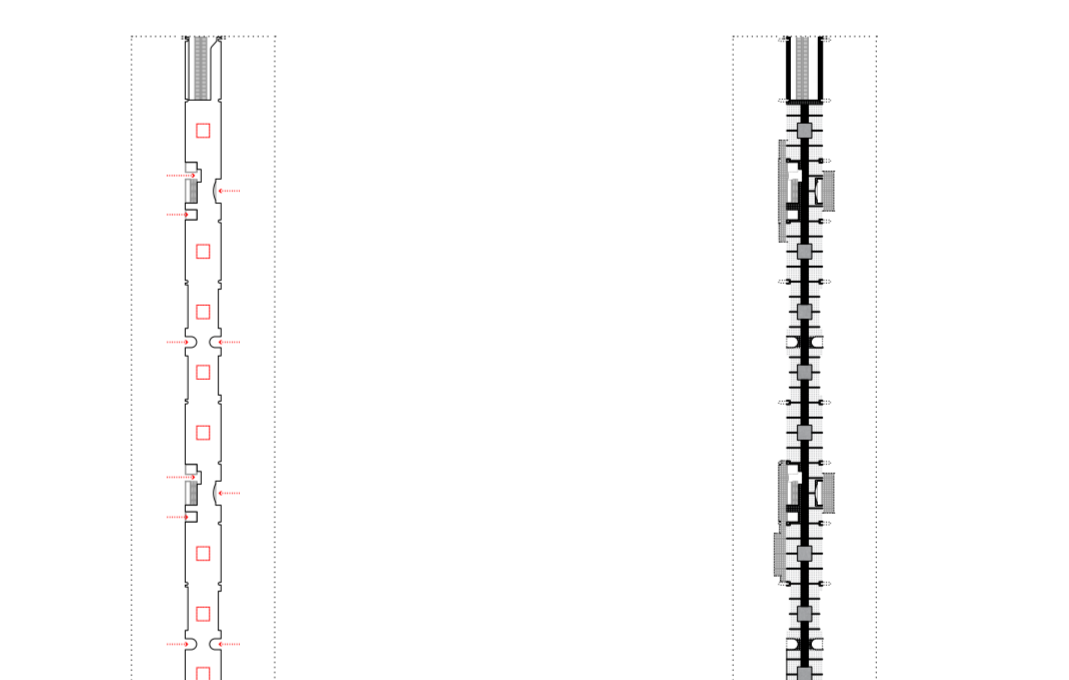
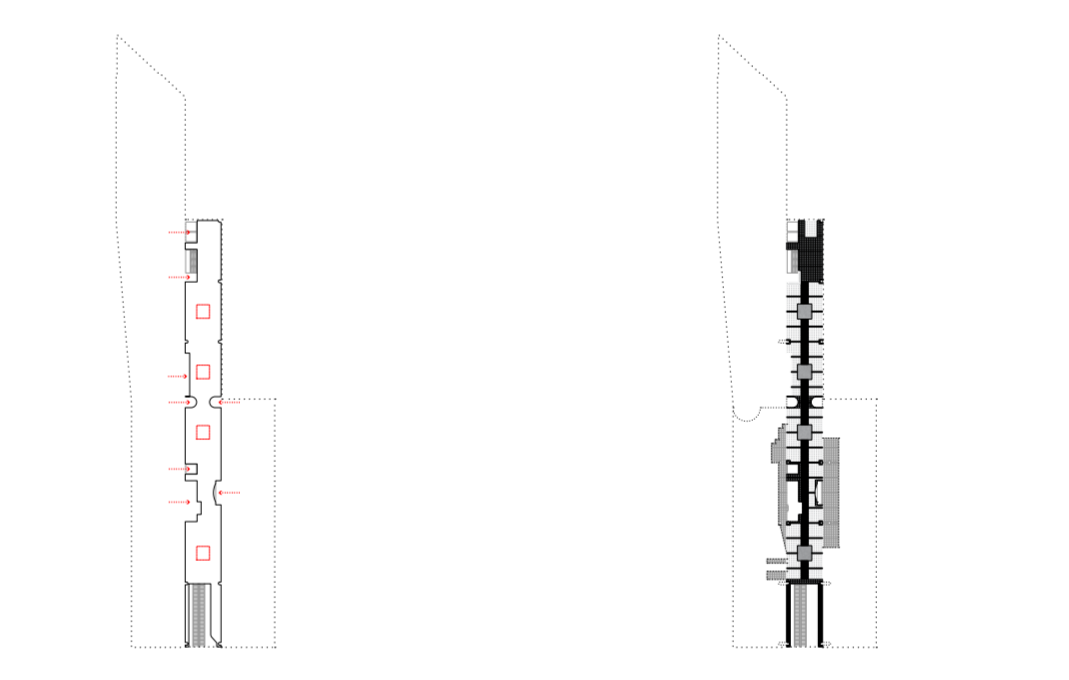
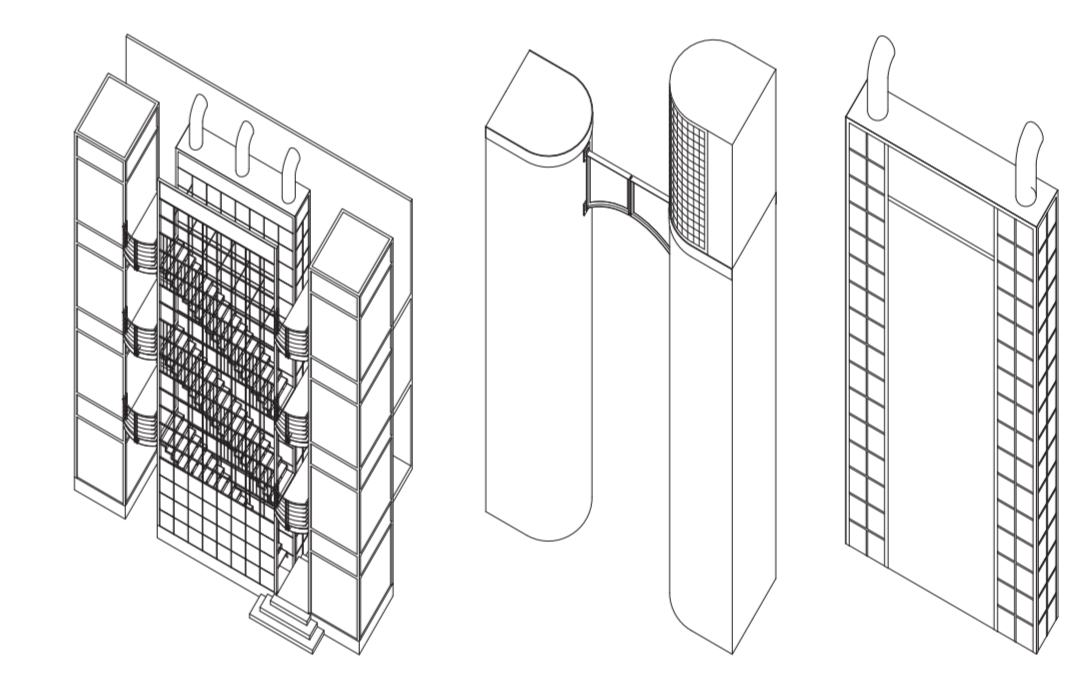
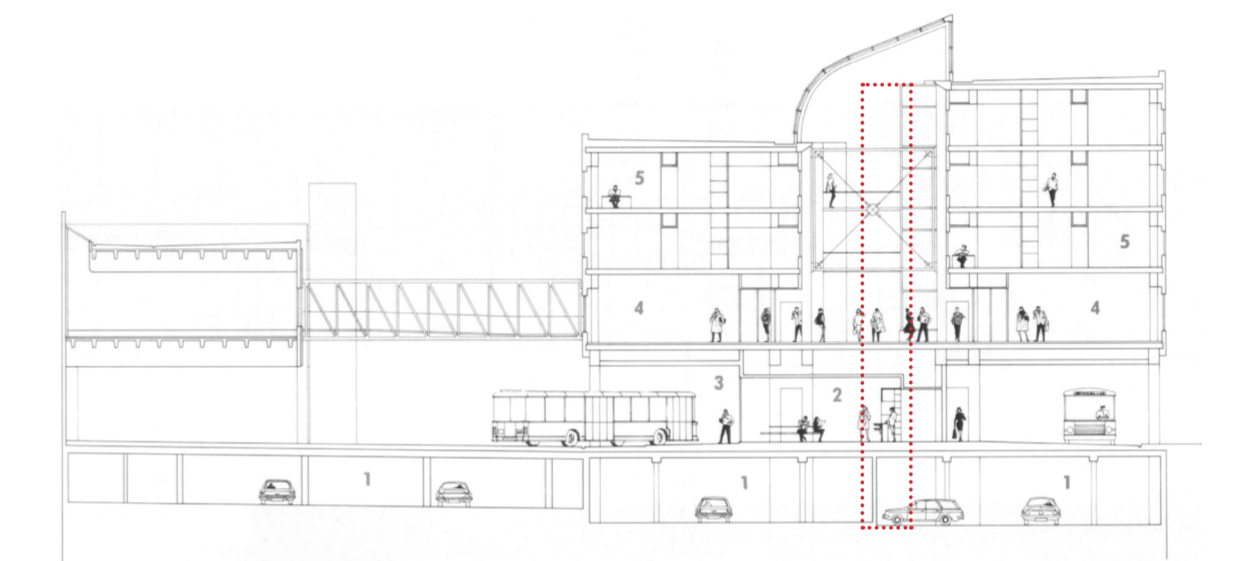
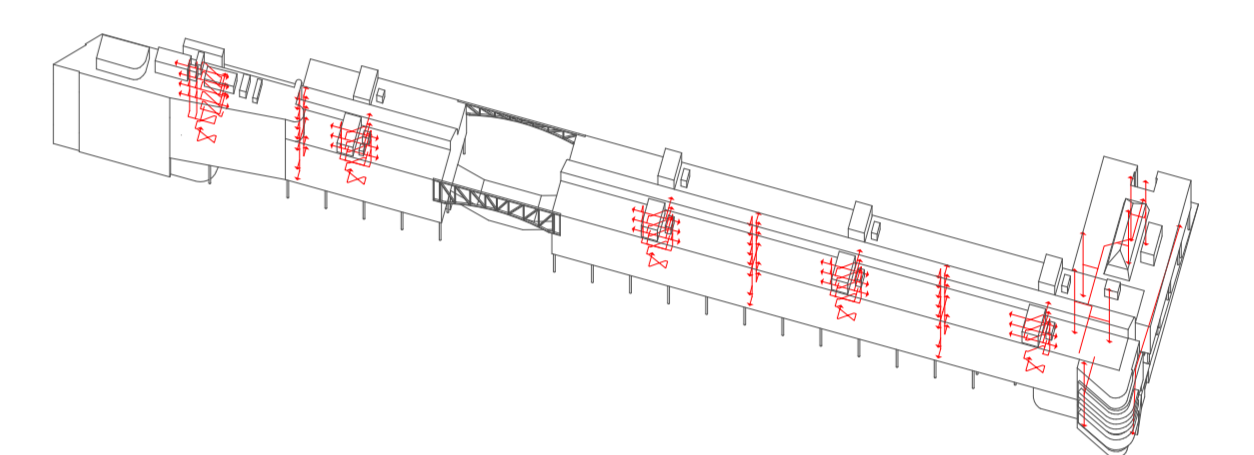

Interior space and the central arcade

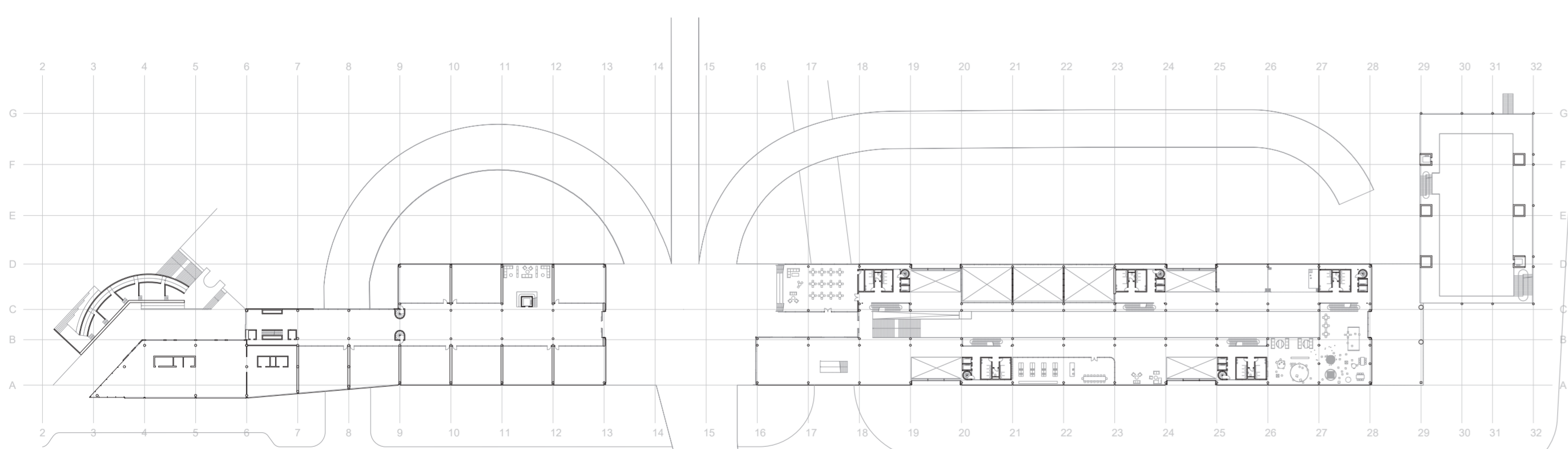
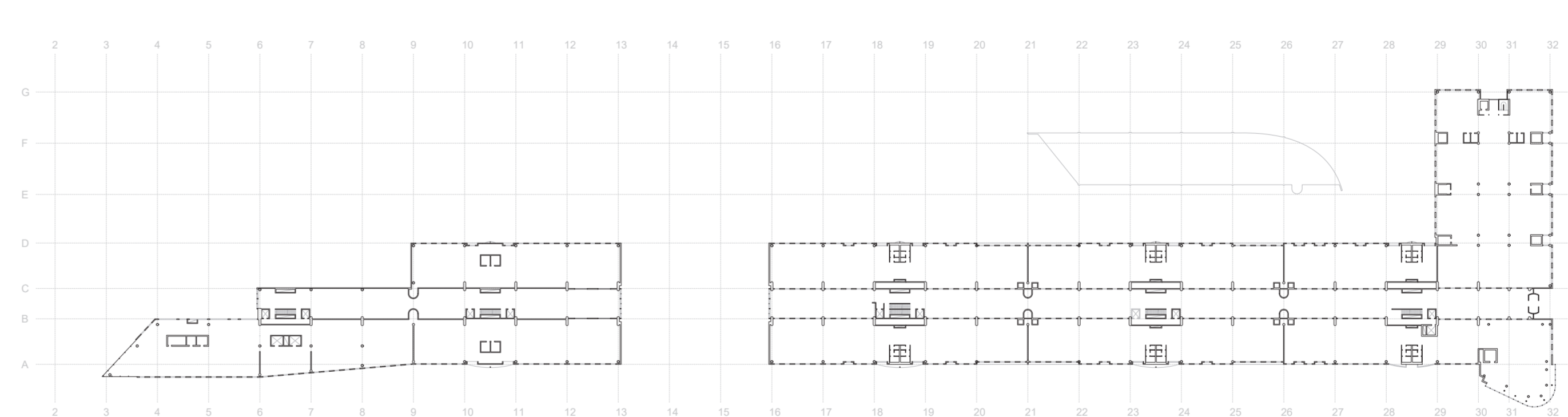
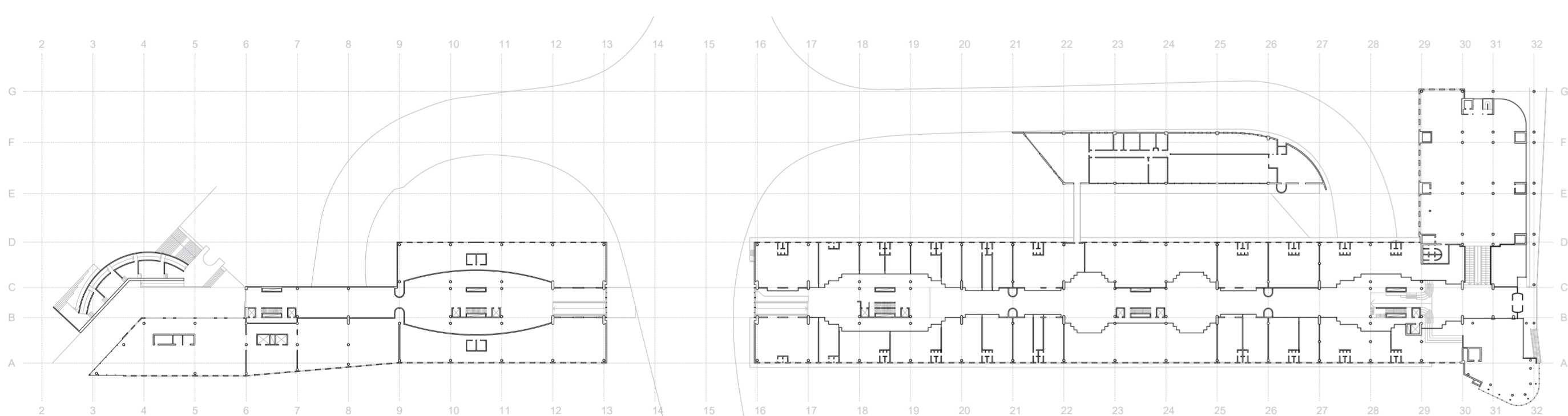

Galleri Oslo and the new public interior

