

Connecting Ship Operation and Architecture in Ship Design Processes

Etienne Gernez

The Oslo School of Architecture and Design, Oslo, Norway

It is challenging to deal with the operation of ships by crew members in ship design processes. This is important because the efficiency and safety of ship operations ultimately depends on the ability of human operators to use the technological systems designed for them, no matter how well the technology might perform. The challenge is that there are limited ship design processes combining coherent coevolution of ship architecture and ship operation. I propose a framework that helps ship designers connect the operation of ships by human operators with the design of ships and ship systems.

Keywords: design (general); operation (general); safety

1. Introduction

Analysis of the actual uses of ship systems by human operators can inform the design of ships and ship systems with the aim of making them safe and efficient to use. However, this analysis is challenging because human-centered design (HCD) methods are not common in ship design practice and research (Lützhöft 2004; Lundh et al. 2011; Lurås & Mainsah 2013; Costa & Lützhöft 2014; Abey Siriwardhane et al. 2015). This research explores how HCD methods can be introduced to the ship design process. In this article, I present a set of human-centered methods structured into a framework that connects the operation of ships by human operators with the design of ships and ship systems.

Rothblum (2000) states that designers need to understand the tasks of the human operators during ship operations and use this understanding to create designs that are compatible with all the systems the ship users interact with. Research on ship accident statistics supports the importance of this claim and shows that most accidents are connected to errors by human operators in their use of and interaction with ship systems (Kataria et al. 2015; Praetorius et al. 2015). There are good reasons to suppose that, similar to safety, the efficiency of ship operations is also closely connected to how ship systems enable the human operators to perform their tasks efficiently.

From a human-centered perspective, a ship can be seen as a complex tool used by human operators to deliver services (Gernez et al. 2014), for example, the service of moving large quantities of cargo from one location to another. I define “ship operations” as the assembly of tasks performed by human operators, using the ship systems, in a sequence that enables the delivery of the ship’s services. I define “ship architecture” as the assembly of systems on the ship that enables the human operators to perform the tasks required to deliver ship services. In this definition, the requirements for the design of ship systems include the need to develop and assemble these systems to address the needs of human operators performing ship operations.

In the next section, I review to what extent human-centered perspectives and methods have been presented in ship design research in relation to describing and designing for ship operations. Then, I present how the framework connecting ship operation and architecture was developed and how it works. I conclude with an evaluation of its functions, what is missing in the framework, and what opportunities for innovation it might open up.

2. Human operations in design for maritime industry

2.1. References to ship operation in ship design research

In the International Marine Design Conference’s (IMDC) 2009 state-of-the-art review of models of ship design processes (Andrews et al. 2009), I found that 11 of the 27 presented models reference the operation of ships, primarily regarding requirements, for example,

Manuscript received by JSPD Committee May 22, 2018; accepted August 8, 2018.

Corresponding author: Etienne Gernez, etienne@opensailing.net

“requirements” (Heather 1993; Graham 1996), “functional requirements” (Andrews 1985; Tibbitts et al. 1993), and “operational requirements” (Andrews 1985; Burcher & Rydill 1995). Other references are made to “functional efficiency” (Andrews et al. 1996; Andrews & Dicks 1997), “reliability, maintainability, availability, and logistics” (Rawson 1986), “systems operating and upkeep philosophies,” (Andrews 1985), and “maintenance philosophy” (Andrews 1985). Of these 11 mentions, seven give some indication of how to deal with ship operations in the design process: “perform need analysis” (Andrews 1985), “operational evaluation” (Heather 1993), “operational simulation” (Tibbitts et al. 1993), and “functional hierarchical decomposition” (Andrews & Dicks 1997). In a model referred to as “The Phases of Ship Design with the Push of Demand and the Pull of Constraints,” Andrews (1985, 101) presents ship operations as demands and constraints embodied by different stakeholders in the design process (“Staff, User departments, Fleet, Fleet support, Lead Shipbuilders, Shipbuilders, Shipyards, Equipment industry”); this is the only example where ship operations are explicitly linked to the work of the ship’s end-users.

The IMDC review from 2009 also mentions systems engineering methods, for instance, methods presented by Elliott and Deasley (2007). Such methods focus on the stakeholders of the design process and base this process on a capability statement and a requirement specification derived from user tests. However, it is unclear whether systems engineering methods are actually being used in the ship design community. Systems engineering methods are criticized by Andrews et al. (2009) for not providing the means to work with “the fundamentally creative elements of design.” Levander (2003) observes that the systems engineering methods need better interfaces between subsystem blocks to create innovative designs.

In summary, the human-centric perspective on ship operations is not always included in ship design processes. When it is included, it is in terms of “requirements” that do not explicitly describe the needs of human operators. There are also few clear mechanisms for how to include these different requirements in the design process. In the HCD tradition, defining “requirements” implies entering into a process of exploring innovation opportunities. This process was originally modelled by Maher and Poon as a co-evolution of problem and solution (Maher 1994; Maher & Poon 1996) and was then used by Dorst and Cross (2001) in engineering design. I analyze this process in more detail in the discussion part of this article.

2.2. Human factors and implementing human-centered design principles in ship design

The human factors and engineering (HF&E) discipline focuses on what requirements will allow human operators to work in a safe and efficient way (Rothblum 2000; The Nautical Institute 2015). The first conference on the application of HF&E principles to the maritime industry occurred in 1977 (Anderson et al. 1977). These principles are now recognized by the International Maritime Organization, which recommends implementing them by following ISO standard 9241-210 (originally ISO 13407) (International Organization for Standardization 2014), thus formally introducing HCD to the maritime industry: “HCD is characterized as a design approach for usability supported by the discipline of human factors/ergonomics” (The Nautical Institute 2015).

In this definition, the HCD process centers around the notions of usability, context of use, and user experience. The process starts with “understanding the context of use” and then “defining the user requirements” followed by two sessions of “rapid prototyping” and “rapid testing” (The Nautical Institute 2015). None of these terms are present in the ship design process model review mentioned previously. Other references show some variation in the sequence and terminology, but they are based on the same principles (ASTM International 2013; American Bureau of Shipping 2014). Task analyses, user interviews, and field observations are cited as recommended methods for the analyzing user needs, and prototyping and evaluation are based on sketches, paper, and software mock-ups that are later reviewed with matter experts or are tested in the field.

The ISO, ASTM, and ABS standard and guidance notes focus on individual systems, but implementing this HF&E-driven HCD process on the scale of a ship design process is more complex: “It is only when the broad form of the [ship] layout has been finalized that issues relating to crewing, ship operations (...) tend to be investigated within the overall design constraints” (Andrews et al. 2006). One reason could be that naval architects are often not trained in working with human factors principles and methods. Of the 27 references in the IMDC review from 2009, “human factors” is mentioned once (Andrews 1998) as a part of management tools, grouped under project management issues and not connected to the scope of the ship design process. With a background in ship navigation and human factors, Lützhöft observed that “challenges include communication with project owners and the rest of the design team and making them aware of the importance of Human Factors” (The Nautical Institute 2015). In addition to being rare in ship design conversations, the topic of human factors might be diluted in the number of conversations taking place: “ensuring the ship is user-friendly starts with the overall concept produced by the naval architect, but is executed over time by many dispersed members of the design team” (The Nautical Institute 2015). There must be many stakeholders involved because the operational considerations grouped under the term “requirements” cover a wide range of expertise: “functional requirements with desired performance, regulatory and legal requirements, regulatory and safety constraints, owner’s and user’s demands, operational scenarios and constraints” (Nowacki 2009).

In summary, human factors provide both a process and some methods to capture and transfer operational requirements, at the system level yet theoretically applicable to the whole ship design process. However, the stakeholders driving this design process might not be used to working with these processes and methods and might not even consider them in the scope of their design project. When additional expertise is brought to the project, it is often late in the design process; it adds to the list of requirements to deal with, and it also adds to the number of stakeholders who need to work together to deal with these requirements.

2.3. Human-centered design practices in the field of human-computer interaction

Nordby and Lurås provide recent examples of research coming within the tradition of human-computer interaction (sometimes called human-machine interaction) and human factors as applied to the maritime industry and specifically to the design of ship bridges. Lurås and Nordby (2014) used field studies to experience and

document the working conditions of ship crews. They also created representations of field insights that reuse competence and visual material from ship design; Nordby proposed a mapping technique based on a ship's 2D layout (Nordby et al. 2011), and Lurås proposed a scenario-mapping technique based on a task analysis (Lurås 2015). Finally, they proposed a model that frames how field studies contribute to design processes in the maritime industry (Lurås & Nordby 2015). The work presented in this article activates these processes, tools, and models, framing them as design activities that analyze how ships are operated in relation to their architecture.

2.4. Summary and reframing

With its traditional technology-centered perspective, ship design research lacks descriptions of how ships are operated by their crew and lacks design activities that connect the use of systems with the design of the systems, from the level of one human operator to the whole-ship level. Human factors approaches use a design process and methods that introduce a human-centered perspective to the design of ship systems. However, it seems that the conversations about human-centered operations of systems are often restricted to human factors specialists and are not consistently used throughout the ship design process. From this analysis, I derived the need for a set of methods and design activities assembled into a framework that would enable the following:

- 1) The introduction of human-centered ship operation into collaborative analyses taking place in the ship design processes.
- 2) The materialization of the relationships between human-centered ship operation and technology-centered ship architecture.
- 3) The use of this relationship-building process as a design activity in ship design processes.

3. Development of the OPAR framework

3.1. The ONSITE project

The Operation-Architecture (OPAR) framework was developed in the ONSITE project at the Oslo School of Architecture and Design. ONSITE aims to connect knowledge about ship operations with ship design processes by using field studies. ONSITE is a practice-based research project; the practice part consists of designing and carrying out field studies with the three industrial partners of the project, whereas the research part consists of analyzing how the performed field studies fit with the industrial partners' design processes. Table 1 presents the field studies performed in ONSITE that have served as support to the development of the OPAR design framework.

In each field study, the industrial partner owns the design process. The field researcher leads the definition of the field study scope and its execution. Workshops organized and facilitated by the field researcher are held before and after the field study together with the industrial partner to ensure that the study deliverables are aligned with the design process the study is informing. The field study results are handed over during a workshop that follows the study. I was the lead field researcher in all three field studies. The

industrial partners also carried out field studies of their own; field study #2 was followed by a test of prototypes in the field, and field study #3 was preceded by another short field study and internal workshops to kick-start the ship design project. The ONSITE field study process is described in more detail as a process (Gernez & Nordby 2018a), a course (Gernez & Nordby 2018b), and a case study (Gernez et al. 2018).

The motivations for the research presented in this article come from the practice of field studies. Within this practice, I needed to describe the operations I observed on ships and to communicate these observations to the industrial partners I worked with. Because the field study process connects to the ship design process, I also needed to create a framework that would enable the integration of the field study data with the data used in the ship design process. This is a common challenge in field studies supporting design processes (Diggins & Tolmie 2003; Kujala et al. 2003).

3.2. OPAR framework development

I created the first version of the framework by putting together the three concept categories I was interested in: the ship design process, the outcome of the ship design process (i.e., the ship itself), and the use of the ship (which I called "operations"). From this first draft, I used two types of research activities to further develop the framework. First, the framework was tested by placing data in it. The available data I had consisted of early ship design data from one of the industrial partners of the project, for example, technical drawings of existing ships, a report of a preliminary field study on an existing ship, early specifications from customers, and pictures of sketches of ship concepts on a whiteboard. In this process, I looked at how the concept categories defined by the framework allowed the data to be sorted. For example, is it possible to place data in all the categories? Are there data that do not fit into one category or that fit into several?

Then, I looked at how this activity of placing data in concept categories might support a generative and evaluative design process; does it enable the generation and evaluation of design proposals? To facilitate this process, I used visual methods to show successive versions of the framework to present, discuss, and criticize them. This was carried out during internal review sessions with another researcher from the ONSITE project and during project seminars with all the ONSITE project industrial partners.

4. The OPAR framework

4.1. What it is and what it does

The framework is presented in Fig. 1. The targeted users of the framework are ship designers and other stakeholders of a design process. The framework consists of a two-dimensional matrix with four parts and four connections between each part. The vertical dimension of the matrix defines what relates to ship operation and what relates to ship architecture, as follows:

- 1) architecture is technology-centric and describes what systems are in place or are considered in the design process; and
- 2) operation is human-centric and describes how the users of the ship might interact with the ship systems.

Table 1 Field studies carried out in the ONSITE project informing the presented research

Field study #	Informing the design of	Design process owner: (industrial partner)	Field study focus	Field methods	Deliverable
1	Ship engine room	Engine room system integrator	User experience during maintenance of engine	User shadowing	Concept for a collaborative design process and collaboration tool to design human-centered engine rooms on ships
2	Ship surveyor portable support tool	Classification society with maritime consultancy services	Tasks performed by a ship surveyor during a ship inspection	User shadowing, semistructured interview	Task analysis, proposition, and evaluation of innovation concepts
3	Ship	Ship designer and builder	1. Ship operations 2. Test of new ship design concept	User shadowing, sketching, and prototyping	Mapping of operations and design guidelines for a new ship concept

The horizontal dimension of the matrix defines what relates to an existing situation in the design process and what relates to a hypothetical situation, as follows:

- 1) as-is: as it exists now, as described by current best practices; and
- 2) concept: as it could be, should be, or ought to be.

Using the framework consists of navigating between the four parts of the matrix to follow an analytic and generative design process. The division into four parts enables to identify what is known and unknown in terms of operation and architecture and to derive or evaluate new concepts based on this analysis. The framework indicates what design methods and activities can be used to navigate from one part to another. In the next section, I describe the methods I have used in the ONSITE cases to navigate the framework. This list of methods is not exhaustive, and other methods can be introduced. Reciprocally, the framework can be used to develop new methods that enable one to navigate it.

The dichotomy of operation/architecture is common in the human factors literature. Lützhöft observed how human operations

adapt to the available architecture: “When designers do not take their views into account, users do adapt to the workplace when forced to, but adaptations and workarounds are signs that the design should have been better” (The Nautical Institute 2015). Lundh et al. (2011) observed how architecture influences operation and might lead to inappropriate operation and increased risks of crew injury.

The dichotomy of as-is/concept is traditional in design and has been used, for example, by Simon (1969), with descriptions by Evans (2014) of how design can be used to explore a future situation and by Krippendorff (2005) of how this is used by designers to challenge existing situations.

4.2. How does it do what it does: observations from our cases

In Figs. 2–12, I present a run-through of how the OPAR framework is designed to be used, with examples of use taken from the cases in the ONSITE project. The process is summarized in Table 2 at the end of this section.

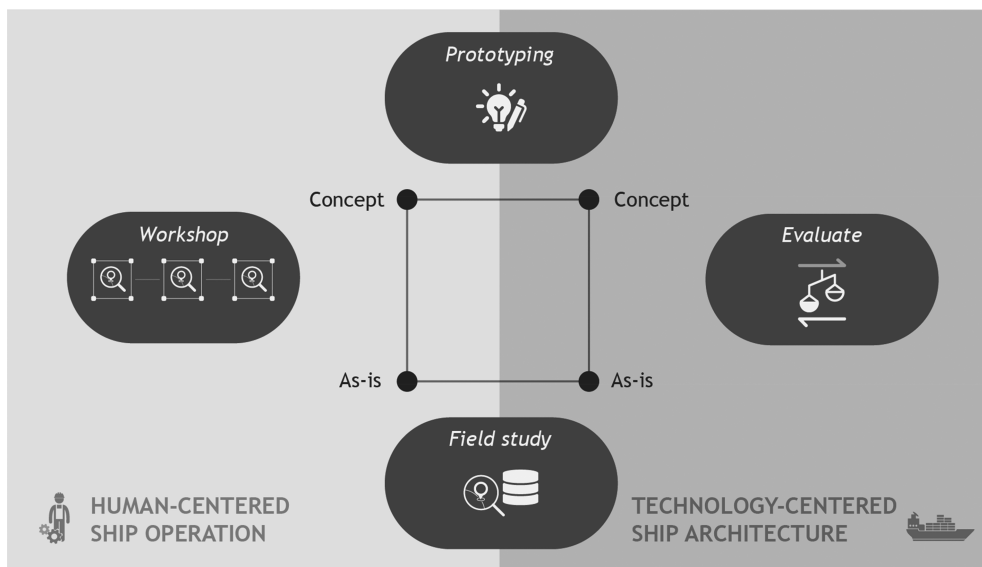

Fig. 1 The OPAR framework

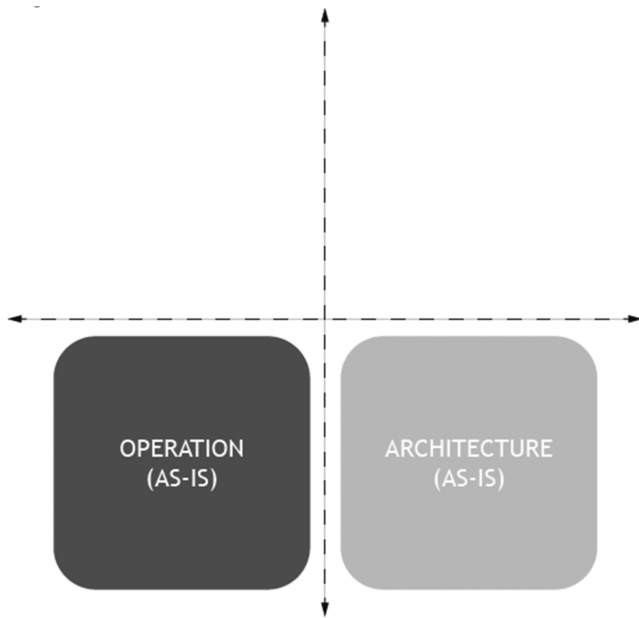

Fig. 2 Establishing a baseline

4.2.1. Establishing a baseline: current operation and current architecture. This is where most design processes start, by analyzing the current existing situation (Fig. 2). Visser observed that the reuse of knowledge from previous design projects is a central approach in design (Visser 2009). In ship design processes, ship designers often start by looking at similar existing ships, looking at 2D drawings of the ships. Such data show “how things are” (for example the layout of the ship), but do not necessarily show “how things work” (for example, how the crew might use the ship).

In the cases with the industrial partners of the ONSITE project, I used field studies on board ships to establish a baseline that described an existing situation in terms of ship architecture and ship operation. Maguire (2001) recommended using this method “when the situation is difficult for (the) user to describe in (an) interview.” I used “shadowing” as one field observation method, where a user is followed when performing a work task. The observer records what the user is doing, what systems are used by the user, and what happens when the user uses the systems (Fig. 4). In other field observation methods, at each step, the user can be asked to explain what he or she is doing (“walk-through” method) or thinking (“think-aloud” method). The user can also be asked to sketch something to explain some concepts visually (Fig. 3). This can be combined with interviews before, during, and after the observation. The systems the users interact with are listed, and the interaction with them is described. The information collected can be mapped using journey mappings (which follow the actions of a user along a timeline). I also used 2D layout mappings to describe the systems present in a working environment.

The collected field data are mostly qualitative and are used to complement the background research carried out by ship designers; the understanding and experience of how ship systems are used by human operators are overlaid on top of data describing ship systems (such as 2D drawings). In the model of Lurås and Nordby (2014) of design-driven field research, experiencing life at sea is fundamental to improving the design judgment of designers, in terms of both the quality of idea generation and the evaluation.

4.2.2. Exploring the operational dimension: from current to future operation. This step (Fig. 5) focuses on the following questions: How do systems in place currently enable their users to perform their work tasks? How could the tasks be performed

Table 2 Summary of activities used in the ONSITE cases in relation to the OPAR framework

	Methods used	Data produced	Connections between operation and architecture
Existing architecture and operation	Search for similar ship Field study observations: Shadowing, walk-through, thinking aloud, interviews	Ship drawings—2D general arrangement Photos, videos, sketches, text observations of users in their working environment	Drawing does not show human operators’ tasks or how they perform them As a whole, gives an understanding of tasks and how they are performed. Individual data can give more details about the user experience in using specific systems
Exploring new operation	Task analysis scenario mapping (layered-scenario mapping or a simpler version) Note: these methods are well suited for workshops, and they require field observations as input	Mapping of tasks performed by human operators, including how the tasks are performed, using what systems; also, observations of the user experience	The mapping gives an understanding of a whole sequence of tasks, so it gives a dynamic understanding of operations, i.e., how combinations of systems independently designed are used together by one user
Connecting new operation with new architecture	Sketching and prototyping: 2D sketching, 3D modelling, scenario mapping, paper/cardboard mock-ups, scenario enacting and filming	Sketches, prototypes in different forms. Evaluation of the sketches: Annotation on sketches, oral discussions, text descriptions	Visual representation of users and/or systems, often in a working environment. Enables facilitating a discussion about the match between the system functionality and the user needs. Immediate feedback by the user can be given when prototyping is carried out with the user
Evaluating new architecture	Not observed in our cases	Not observed in our cases	Not observed in our cases

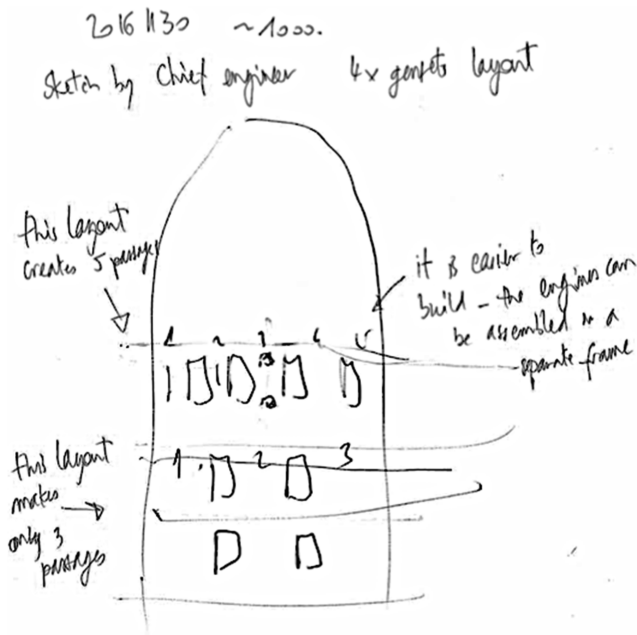

Fig. 3 Sketch of two possible engine layouts, done by a chief engineer during a field study. Sketch of two possible engine layouts, done by a chief engineer during a field study (hand-written notes are the author's)



Fig. 4 A crew member shows the narrow passage between two engines

otherwise by the user? What might this imply for the design of new systems?

In our cases, I used both task analysis (Kirwan & Ainsworth 1992) and layered-scenario mapping (Lurås 2015) to explore these questions. I used them to describe and analyze an existing (observed) situation before proposing potential design interventions, using a “zoom—intervention—problem” analysis technique (Sevaldson et al. 2012). Because technology-centered design processes might lack the terminology to describe and analyze the experience of human operators, I focused on participatory methods such as workshops, where I asked workshop participants to collaboratively 1) describe the current operation and 2) analyze what might be problematic to 3) agree on the needs for an improved operation. When design stakeholders from different companies participate in the same workshop, it creates the opportunity to discuss how the observed operational problems might be linked back to their respective design processes. This helps design stakeholders build ownership into the motivations, impacts, and importance of operational requirements. It also motivates the stakeholders to find a way to integrate these requirements early into their own design process, across their respective design processes, and into their respective companies and organizations.

I experienced such a case in field study #1 and described it in detail in another article (Gernez et al. 2018). For field study #3, I ran a workshop before the field study itself to gather the ship design team's knowledge of how current ship operations were performed; I used a simplified form of layered-scenario mapping (Fig. 6). I used a paper roll as a timeline and broke down an operation into small steps using sticky notes. For each step of the operation, I created hypotheses about what crew members might be involved in, what systems they might use, and how their actions might impact the safety and efficiency of the operation. The discussion was facilitated by 2D drawings of a ship, meaning that in effect, architecture data were translated into operation data. This mapping exercise also enabled the ship designers to identify what parts of the operations they were not familiar with and use this identification as a basis for scoping the subsequent field observations. The hypotheses set down on the scenario map were explored during the field study. After the field study, the scenario map was revisited and expanded with the field data; it was then used as a basis to generate and test new concepts regarding how to operate the ship differently and what requirements this change would create for new systems designed to enable this operation.

This type of scenario mapping enabled a new form of prototyping in the ship design process that did not involve 3D digital modeling or physical model building. This form of operation prototyping was absent from the ship designer's current design process, and the ship designers involved in that case deemed it useful and valuable.

4.2.3. Connecting operational and architectural concepts. This step (Fig. 7) focuses on finding technology-centered architectural solutions to the human-centered operational needs. This is carried out through sketching and prototyping, which are fundamental activities in design (Fallman 2003; Prats et al. 2009; Buxton 2010). I used prototyping to explore “how things work” to create situations where the experience of the user of a system can be analyzed. What matters is not the accuracy of the representation of the system, its user, or the user experience, but rather how the prototype enables us to analyze

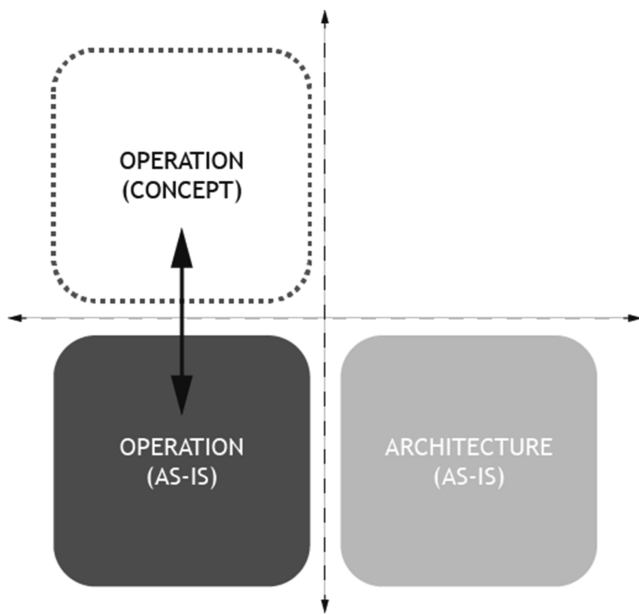

Fig. 5 Exploring the operational dimension

and evaluate the match between the system functionality and the user needs.

In the ONSITE cases, I worked with prototyping 1) during field studies and 2) following the field study in participatory workshops. I used sketching and prototyping activities such as 2D sketching, 3D

modeling (Figs. 8 and 10), scenario mapping (Fig. 6), and paper/cardboard mock-ups (Fig. 11), as well as scenario enacting and filming (Fig. 9). The advantage of prototyping during a field study is that one has the opportunity to get immediate feedback from the user in its context of use.

4.2.4. Evaluating new architecture with regard to existing architecture. This step focuses on analyzing a potential new design from the perspective of its system architecture (Fig. 12). I did not go through this phase in the ONSITE cases. I propose that it could be carried out by comparing the new design with a previous iteration or with a design that was used as a starting point.

It is often the case in ship design that the design process is started by looking for ships of similar dimensions and capability and modifying these existing ships to reach a new design. In the language of the OPAR framework, this type of practice goes directly from an existing architecture to a new architecture without going through the three other steps that deal with human-centered operational considerations. The problem with this approach is that it propagates a whole design (both operation and architecture), including details that might not match human-centered operational requirements. This approach is often based on the use of “design spiral” ship design models, and it was criticized by Levander (2003): “this model easily locks the naval architect to his first assumption and he will patch and repair this first and only design concept rather than generate alternatives.” In theory, using OPAR would help the design team uncover so-called “unknown unknowns” by combining conversations with visual thinking, and thus stimulating reflections. This discussion is developed in more detail



Fig. 6 Workshop before a field study, where the operation is mapped with sticky notes on a paper roll (bottom right corner) using 2D drawings of a ship to support the discussion

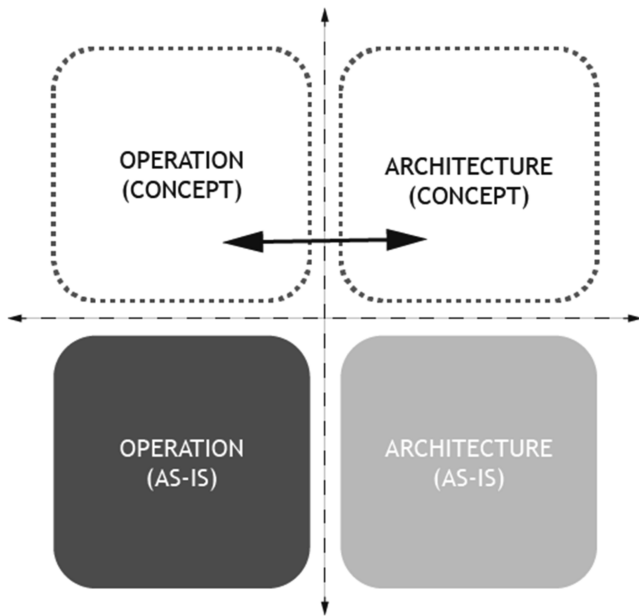

Fig. 7 Connecting operational and architectural concepts

in the discussion about the problem–solution coevolution model. Table 2 and Fig. 13 summarize the methods used in the ONSITE cases in relation to the OPAR framework.

5. Discussion

I will discuss the use of the framework in a generic design process before evaluating how the framework addresses the three objectives defined in the introduction. I will also discuss what the framework

lacks and what potential improvements would be interesting to research.

5.1. The functions of OPAR in a design process

As analyzed by Visser (2009), different forms of design activities and processes have a number of similarities. Design is a problem-solving activity, as originally formulated by Simon (1969), with the particularity that design problems are often ill-defined or wicked problems (Simon 1973; Rittel & Webber 1973). Working with such problems requires making a distinction between problem-setting and problem-solving (Schön 1983) or, as Buxton (2010) put it, respectively, “getting the right design” and “getting the design right.” Coming from the field of computing science, Maher followed this line of thinking and proposed a model of problem-solving based on an iterative and interactive joint exploration of the problem space and the solution space (Maher 1994; Maher & Poon 1996).

In the context of this work, I propose to apply Maher’s model of “problem–solution coevolution” to the two dimensions of ship architecture and ship operation; ship operation creates requirements that specify the problem space for which ship architecture solutions that satisfy these requirements need to be found. Maher’s model has been applied to analyze a number of different design processes (Maher & Tang 2003) and to study creativity (Dorst & Cross 2001) and collaboration (Wiltchnig et al. 2013). A number of observations can be derived from the conclusions of these studies.

Defining the problem space: The first step of an exploratory design process consists of specifying and defining a problem space. I argue that the ship operation dimension should be used to specify the problem space. Doing so enables one to start the ship design process with the step of specifying a ship, based on the requirements of its future owner, in a conversation with the ship designer; this is also called the “requirements elucidation phase” (Andrews 2003b, 2011). In this phase, it is important to use human-centered methods,

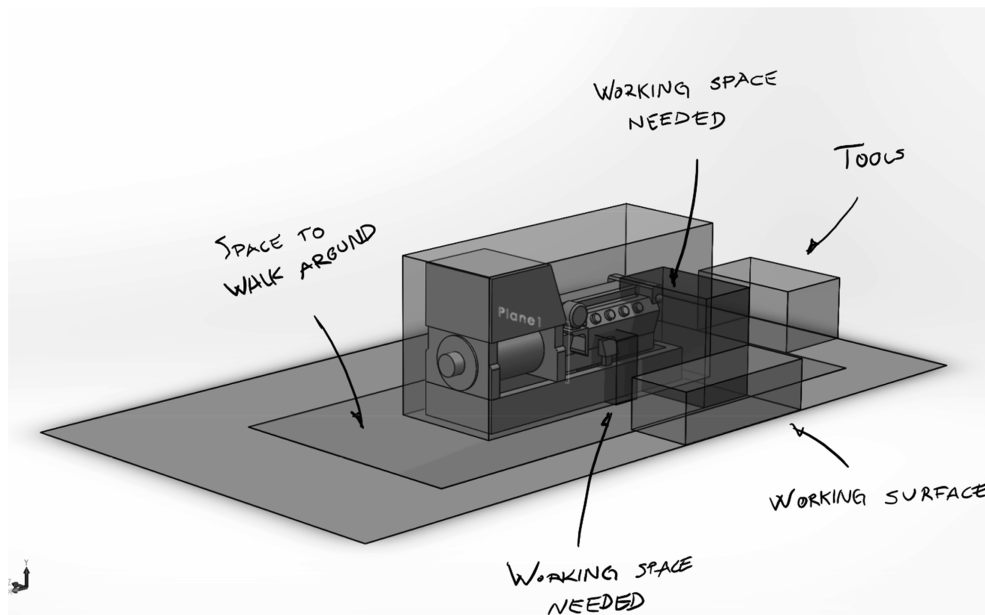

Fig. 8 Digital drawing used to prototype a concept developed after a field study and refined later in a participatory workshop

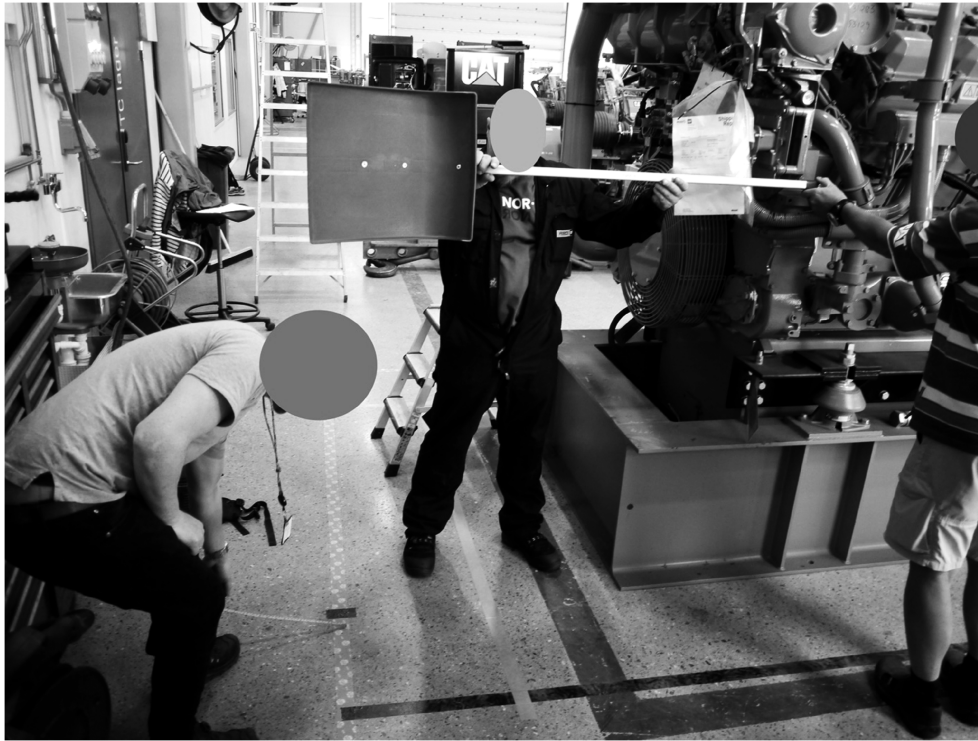

Fig. 9 Enacting engine servicing scenarios with props around an actual engine to inform a prototype of engine service space made in a 3D CAD program (see next Figure)

such as field observations, to include the requirements of the ship's end-users in the specification of the problem space. Failing to do so implies that the process would start with a problem space that might not contain the requirements necessary to achieve operational safety and efficiency and that this would thus lead to suboptimal solutions.

Exploring the solution space on the premises of the problem space: In Maher's model, "the design process iteratively searches each space using the other space as the basis for a fitness function when evaluating the alternatives" (Maher & Tang 2003). This means that not only do the ship operations need to be adapted to the functionalities offered by the ship architecture, but the ship architecture also needs to be evaluated with regard to how it might enable human operators to perform the daily tasks that constitute the ship operations.

Heuristics and transitions: Maher studied the cognitive activities used by designers when navigating inside and across the problem and solution spaces. In the problem space, these include adding and refining problem requirements, searching for new problem requirements, or reexamining existing problem requirements. In the solution space, these include drawings of solutions, evaluating solutions, and reasoning about the interactions between the current solution and its environment. Although the activities proposed by the OPAR framework seem to share some similarities with what Maher observed, it would be beneficial for the further development of OPAR to systematically explore what type of cognitive activities might enable a deeper, faster exploration of the operation and architecture spaces, with stronger connections among them.

Creativity when creating connections: Dorst & Cross (2001) observed that "a creative event occurs as the moment of insight at which a problem-solution pair is framed (...). Studies of expert and

outstanding designers suggest that this framing ability is crucial to high-level performance in creative design." This means that the ability to connect human-centered operational requirements with technology-centered architecture solutions is fundamental and that this ability needs to be developed in the community of ship design.

Leadership and distributed competence: In their observations of collaborative teams, Wiltchnig et al. (2013) remarked that it was

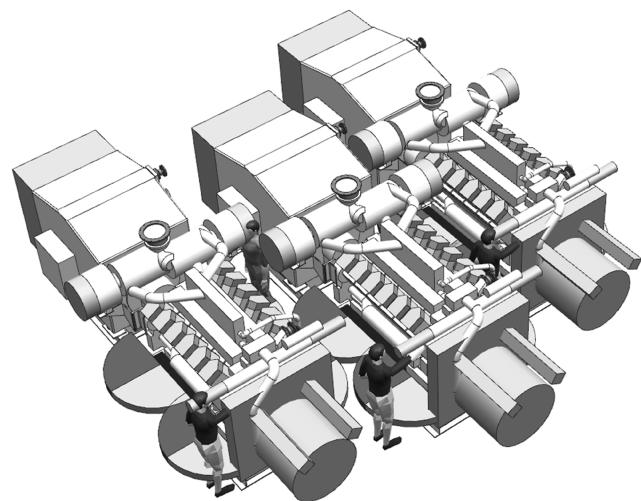

Fig. 10 Prototyping of an engine service space visualization using 3D CAD modeling based on a scenario-enacting session (see previous Figure)



Fig. 11 Prototyping using paper and cardboard during a field study

often the team leader who initiated design discussions by “mentioning or amending a design requirement.” In the case of ship design, one could ask, what is the ability of the naval architect, who would be more at ease working with the solutions space in the architecture dimension, to revisit requirements in the operation space? What is the ability of a human factors expert, who would be more at ease working with the problem space in the operation dimension, to revisit requirements in the architecture space? What is their ability to work together to make connections between these two spaces? This implies that there is a need for facilitation and translation competences in the team, and the OPAR framework could help in training a team member for it.

5.2. Evaluation of the framework

5.2.1. Introducing human-centered ship operation into collaborative analyses in ship design processes. The OPAR framework introduces the notions of users, tasks, and use scenarios to describe the current state of ship operations and what might be other ways to perform these operations. These notions are introduced in the framework via recommended methods, such as field studies, task analysis, and scenario mapping. These methods are not new, nor is their use in a design process. In that sense, OPAR is built on known and practiced methods. However, these methods might be more familiar to human factors practitioners and industrial designers. OPAR places these methods as support methods by which to discuss other aspects of ship design that are more familiar to naval architects, ship designers, and systems engineers.

In summary, OPAR makes two moves:

- 1) It sets in the same place notions and methods that are familiar to different groups of users.
- 2) It gives equal importance to each group of notions and methods.

In the experience with the ONSITE cases, I observed that this second move is important. Although working together on the description of a design case, one of the informants, an engine room designer, explained that “designers [including this informant] are by all means aware of the working space when making their decisions. However, a working space is often looked upon as something static, and the ergonomic perspective is somehow neglected. For example,

I consider an object that needs to be pulled out, but tend to overlook, or at least underestimate, the physical presence and movement of the persons surrounding that object in that particular operation.”

5.2.2. Materializing relationships between human-centered ship operation and technology-centered ship architecture. Using the OPAR framework implies using methods that trigger the need for design teams to address questions that deal with operation and architecture, both from an existing and a future perspective:

- 1) Do the in-built functions of the ship match with what the ship is supposed to be able to do in connection with its business plan and initial specifications?
- 2) Are the tasks given to the users organized in a way that enables the users to perform the tasks?

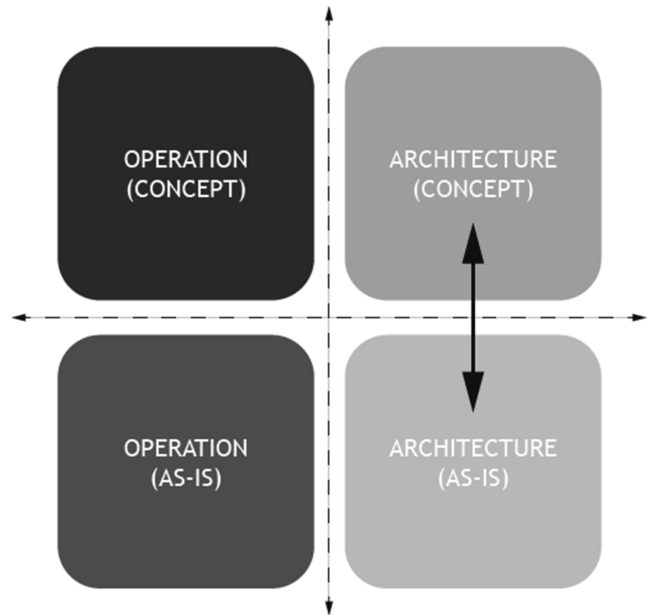

Fig. 12 Evaluating the new architecture

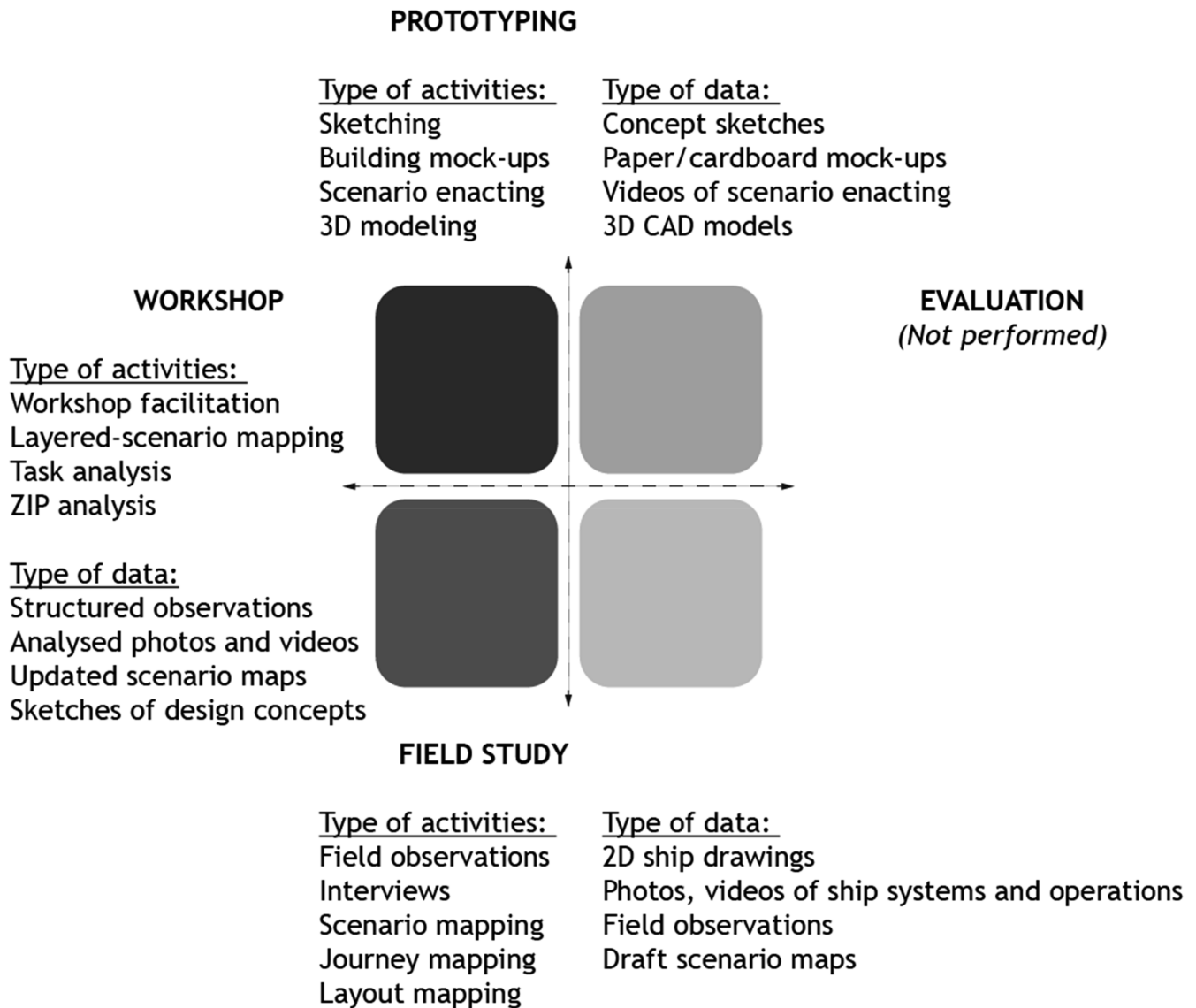

Fig. 13 Summary of methods and data used in the ONSITE cases in relation to the OPAR framework case

- 3) Does the ship have the systems and components that enable the users to perform their tasks to fulfill the functions of the ship?
- 4) Is the ship designed around a crew architecture and role distribution that enables the crew to use the systems on board to perform their tasks?
- 5) What is known about the operation and architecture, and how are they currently matched?
- 6) What information would be needed to create new operation and architecture concepts and new matches between operation and architecture?

The methods contained in OPAR generate a data output that connects operation with architecture. For example:

- 1) Task analysis methods describe how human operations are carried out, using what systems, and describing the experience of the user.

- 2) Scenario-mapping methods describe a sequence of tasks, which enables one to show how a variety of systems are used together, creating requirements for harmonization in the design of these systems instead of designing them as individual workstations.
- 3) Sketching and prototyping methods enable communication with other team members and ideally with end-users themselves about how a system could work and how a user might use it.

5.2.3. Building relationships between operation and architecture as a design activity in ship design processes. In terms of process, the use of OPAR is complementary to ship design processes and HCD processes originating from human factors. In terms of design activities, the use of OPAR generates data useful for ship design, for example, data traditionally used in ship design processes

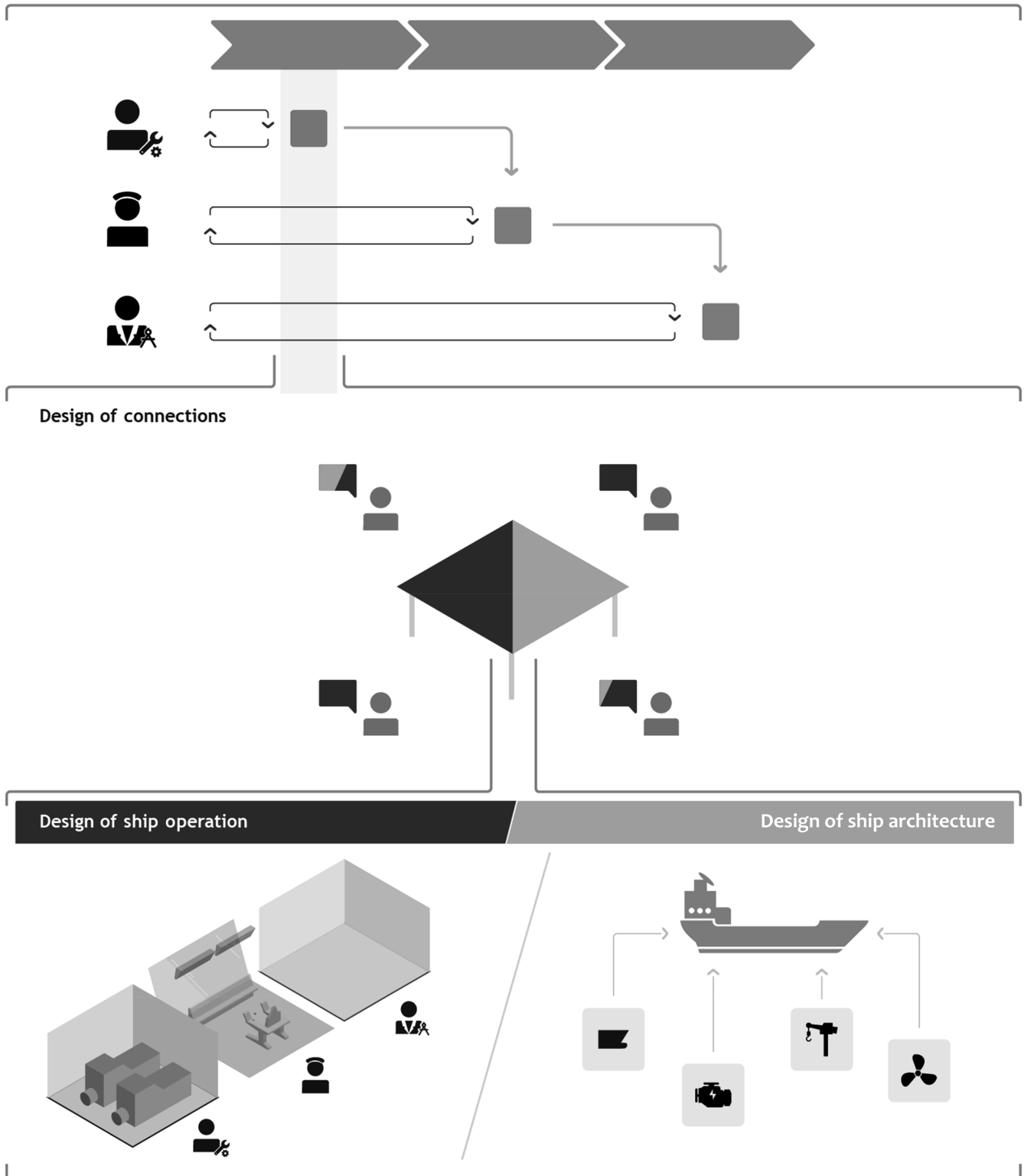

Fig. 14 OPAR as the basis for reframing ship design: a framework for designing connections between ship operation and architecture

(such as 2D drawings or 3D models), data that describes user experiences (for example, task analyses and scenario mappings), and data that supports creative processes (such as observations, reflections, sketches, and prototypes). OPAR is based on field

experience, which influences design judgment. Using OPAR enables design teams to reflect on how the problem—operation space is specified and how the solution architecture—space fits with the problem space.

In summary, OPAR supports the three activities of the design-driven field research model proposed by Lurås and Nordby (2014): data collection, reflection, and experience. OPAR also extends this model from a single field researcher perspective to a team perspective and from the field study to the subsequent design process.

5.3. Further development

The cases carried out in the ONSITE project did not include the last part of the framework (evaluating new architecture). It would be interesting to study the handover from the team that works with field observations to the teams that work with design and engineering, if they are not already working with each other. I also assembled the framework through cases, and as a result, I have not been able to observe how to use it in continuity from the start of a design project.

I did not describe the “diagonal cases” of the use of OPAR in this article, which include 1) connecting existing operation with new architecture and 2) connecting existing architecture with new operation. The first one is actually a case of retrofit, for example, when systems or hardware are updated on board a ship that has been at sea for some time. I recommend first performing an analysis of the existing operation and architecture, to make sure the retrofit is designed to answer some specific needs. There also needs to be an evaluation of how to adapt the current operation to the retrofit and probably how to design a new form of operation based on the new architecture. The second case, for example, could be related to changing operational procedures on board an existing ship without changing its systems or hardware. In that case, this process can inform a future design process by highlighting the shortcomings of the existing one. It would be interesting to study how OPAR supports these two processes and what methods are suitable for use in these cases.

6. Conclusion: Implications for ship design

OPAR is a design framework that supports the conversations of design stakeholders from different disciplines around two main themes: human-centered ship operation and technology-centered ship architecture. For this conversation to happen, there is a need to reframe the whole ship design process as a HCD process based on a succession of interactions between ship design stakeholders. Figure 14 illustrates a proposal for such reframing.

Replacing OPAR at the center of this reframing implies understanding ship design as a three-fold activity:

- 1) the design of human-centered operations that enable the ship to perform as desired;
- 2) the design of an architecture that enables its operators to perform their operations; and
- 3) the design of connections between operation and architecture, between current and future situations, and between the design stakeholders involved in this overall multidisciplinary, collaborative process.

This reframing could potentially enable the following:

- 1) Replacing aspects that are traditionally considered project management issues at the center of the design process, for instance, which design stakeholders should be involved in the process and when and how they should be involved. This refers to the observation by Ulstein and Brett (2012) that the

management of the ship design processes is critical to the outcome of the processes and that there is an identified lack of a process management layer in existing ship design processes.

- 2) Studying the operation of similar ships and exploring how to specifically design for operations. Andrews (2003a) refers to the challenges of building full-scale ship prototypes as one important problem that impacts the safety and efficiency of ship operations. Designing for operation would instead focus on exploring how ship systems are used and how their operation might impact safety and efficiency. Ship simulators are commonly used for this task, but they are expensive to use and are not modular. There seem to be interesting alternatives in the use of virtual and augmented reality technology, but only if they are part of a design framework (Kristiansen & Nordby 2013).
- 3) A more systematic focus on knowledge transfer between design stakeholders by stimulating their interaction and emphasizing the need to develop bridging approaches between different disciplines.

References

- ABEYSIRIWARDHANE, A., LÜTZHÖFT, M., PETERSEN, E. S., AND ENSHAEL, H. 2015 Future ship designers and context of use: Setting the stage for human centred design, *Proceedings, The International Conference on Marine Design, The Royal Institution of Naval Architects*, September 2–3, London, UK, 1–16.
- AMERICAN BUREAU OF SHIPPING. 2014 *Guidance Notes on the Application of Ergonomics to Marine Systems*, Houston, Texas: American Bureau of Shipping.
- ANDERSON, D., ISTANCE, H., AND SPENCER, J. 1977 Human factors in the design and operation of ships, *Proceedings, Papers Presented to the First International Conference on Human Factors in the Design and Operation of Ships*, February 1977, Gothenburg, Sweden, The Conference Organising Committee.
- ANDREWS, D. J. 1985 An integrated approach to ship synthesis, *Transactions of The Royal Institution of Naval Architects*, **128**, 73–102.
- ANDREWS, D. J. 1998 A comprehensive methodology for the design of ships (and other complex systems), *Proceedings of the Royal Society of London A: Mathematical, Physical and Engineering Sciences*, **454**, 187–211.
- ANDREWS, D. J. 2003a A creative approach to ship architecture, *International Journal of Maritime Engineering*, **145**(3), 229–252.
- ANDREWS, D. J. 2003b Marine design—Requirement elucidation rather than requirement engineering, *Proceedings, 8th International Marine Design Conference*, May 5–8, National Technical University of Athens, Athens, Greece, IMDC.
- ANDREWS, D. J. 2011 Marine requirements elucidation and the nature of preliminary ship design, *Transactions of the Royal Institution of Naval Architects Part A: International Journal of Maritime Engineering*, **153**(Part A1), 23–40.
- ANDREWS, D. J., CUDMORE, A., HUMBLE, P., AND WILSON, D. 1996 SUBCON—a new approach to submarine concept design, *Proceedings, Warship 96, Naval Submarines 5*, June 1996, The Royal Institution of Naval Architects, London, UK, RINA.
- ANDREWS, D. J. AND DICKS, C. A. 1997 The building block design methodology applied to advanced naval ship design, *Proceedings, IMDC 1997*, June 23–25, University of Newcastle, Newcastle upon Tyne, UK, IMDC.
- ANDREWS, D. J., PAPANIKOLAOU, A., ERICHSEN, S., AND VASUDEVAN, S. 2009 IMDC state of the art report: Design methodology, *Proceedings, IMDC 2009*, May 26–29, Norwegian University of Science and Technology (NTNU), Trondheim, Norway, IMDC.
- ANDREWS, D. J., PAWLING, R., CASAROSA, L., GALEA, E., DEERE, S., LAWRENCE, P., GWYNNE, S., AND BOXALL, P. 2006 Integrating ship design and personnel simulation, *Proceedings, INEC 2006*, March 6–10, Institute of Marine Engineering, Science and Technology, London, UK, WMTC IMarEST.
- ASTM INTERNATIONAL. 2013 *ASTM F1166-07 Standard Practice for Human Engineering Design for Marine Systems, Equipment, and Facilities*, West Conshohocken, PA: ASTM International.
- BURCHER, R. AND RYDILL, L. J. 1995 *Concepts in Submarine Design*, Vol. 2, Cambridge, UK: Cambridge University Press.
- BUXTON, B. 2010 *Sketching User Experiences: Getting the Design Right and the Right Design*, San Francisco, CA: Morgan Kaufmann.

- COSTA, N. A. AND LÜTZHÖFT, M. 2014 The values of ergonomics in ship design and operation, *Proceedings, Human Factors in Ship Design and Operation Conference*, February 26–27, London, UK, The Royal Institution of Naval Architects.
- DIGGINS, T. AND TOLMIE, P. 2003 The “adequate” design of ethnographic outputs for practice: Some explorations of the characteristics of design resources, *Personal and Ubiquitous Computing*, **7**(3–4), 147–158.
- DORST, K. AND CROSS, N. 2001 Creativity in the design process: Co-evolution of problem–solution, *Design Studies*, **22**(5), 425–437.
- ELLIOTT, C. AND DEASLEY, P. 2007 *Creating Systems that Work: Principles of Engineering Systems for the 21st Century*, London, UK: Royal Academy of Engineering.
- EVANS, M. 2014 Researching the future by design, *The Routledge Companion to Design Research*, New York, NY: Routledge Handbooks Online.
- FALLMAN, D. 2003 Design-oriented human-computer interaction, *Proceedings, The SIGCHI Conference on Human Factors in Computing Systems (CHI’03)*, April 5–10, Fort Lauderdale, FL, ACM, 225–232.
- GERNEZ, E. AND NORDBY, K. 2018a Implementing design-driven field research in maritime design, *International Journal of Marine Design*, in press.
- GERNEZ, E. AND NORDBY, K. 2018b A 10-day course to plan and execute field studies for maritime design processes, *International Journal of Marine Design*, in press.
- GERNEZ, E., NORDBY, K., SEIM, Ø., OLAF BRETT, P., AND HAUGE, R. 2018 Human-centered, collaborative, field-driven design—A case study, *Proceedings, 13th International Maritime Design Conference (IMDC)*, June 10–14, Helsinki, Finland, Aalto University.
- GERNEZ, E., NORDBY, K., AND SEVALDSON, B. 2014 Enabling a service design perspective on ship design, *Transactions of The Royal Institution of Naval Architects*, **156**, Part C1 2014, 29–39.
- GRAHAM, T. 1996 Design methodology for small fast planning craft, MSc Dissertation in Naval Architecture, London, UK, University College London, Department of Mechanical Engineering.
- HEATHER, R. 1993 Discussion to ‘the management of warship design’ by Andrews, *RINA Transactions*, **135**, 1–24.
- INTERNATIONAL ORGANIZATION FOR STANDARDIZATION. 2014 *ISO 9241-210: 2010—Ergonomics of Human-System Interaction—Part 210: Human-Centred Design for Interactive Systems*, Brussels, Belgium: International Organization for Standardization.
- KATARIA, A., PRAETORIUS, G., SCHRÖDER-HINRICHS, J.-U., AND BALDAUF, M. 2015 Making the case for Crew-Centered Design (CCD) in merchant shipping, *Proceedings, 19th Triennial Congress of the IEA*, August 9–14, Melbourne, Australia.
- KIRWAN, B. AND AINSWORTH, L. 1992 *A Guide to Task Analysis*, Boca Raton, FL: CRC Press, Taylor and Francis Group.
- KRIPPENDORFF, K. 2005 *The Semantic Turn: A New Foundation for Design*, Boca Raton, FL: CRC Press.
- KRISTIANSEN, H. AND NORDBY, K. 2013 Towards a design simulator for offshore ship bridges, *Proceedings, The 27th European Conference on Modelling and Simulation (ECMS)*, May 27–30, Ålesund, Norway, European Council for Modeling and Simulation, 212–218.
- KUJALA, S., KAUPPINEN, M., NAKARI, P., AND REKOLA, S. 2003 Field studies in practice: Making it happen, *Proceedings, 9th IFIP TC13 International Conference on Human-Computer Interaction*, September 1–5, Zurich, Switzerland, Swiss Federal Institute of Technology (ETH), 359–366.
- LEVANDER, K. 2003 Innovative ship design, *Proceedings, IMDC 2003*, May 5–8, Athens, Greece, National Technical University of Athens.
- LUNDH, M., LÜTZHÖFT, M., RYDSTEDT, L., AND DAHLMAN, J. 2011 Working conditions in the engine department—A qualitative study among engine room personnel on board Swedish merchant ships, *Applied Ergonomics, Special Section: Ergonomics, Health and Working Time Organization*, **42**(2), 384–390.
- LURÁS, S. 2015 Layered scenario mapping: A multidimensional mapping technique for collaborative design, *CoDesign*, **12**, 1–18.
- LURÁS, S. AND MAINSAH, H. 2013 Reaching hard-to-reach users using online media to get a glimpse of work in marine contexts, *Interactions*, **20**(6), 32–35.
- LURÁS, S. AND NORDBY, K. 2014 Field studies informing ship’s bridge design, *Proceedings, The Human Factors in Ship Design and Operation Conference*, February 26–27, London, UK, The Royal Institution of Naval Architects.
- LURÁS, S. AND NORDBY, K. 2015 Shaping designers’ sea sense: A guide for design-driven field research at sea, *Proceedings, The International Conference on Marine Design*, September 2–3, London, UK, The Royal Institution of Naval Architects.
- LÜTZHÖFT, M. 2004 “The Technology is Great When it Works”: *Maritime Technology and Human Integration on the Ship’s Bridge*, Sweden: Graduate School for Human-Machine Interaction, Division of Quality and Human-Systems, Engineering Department of Mechanical Engineering, University of Linköping, Linköping, Sweden.
- MAGUIRE, M. 2001 Methods to support human-centred design, *International Journal of Human-Computer Studies*, **55**(4), 587–634.
- MAHER, M. L. 1994 Creative design using a genetic algorithm, *Proceedings, Computing in Civil Engineering, First Congress in Conjunction with A/E/C Systems ’94*, June 20–22, Washington, D.C.
- MAHER, M. L. AND POON, J. 1996 Modeling design exploration as co-evolution, *Computer-Aided Civil and Infrastructure Engineering*, **11**(3), 195–209.
- MAHER, M. L. AND TANG, H.-H. 2003 Co-evolution as a computational and cognitive model of design, *Research in Engineering Design*, **14**(1), 47–64.
- NORDBY, K., KOMANDUR, S., LANGE, C., AND KITTILSEN, A. 2011 Mapping of work areas in a platform supply vessel: A case study, *Human Factors in Ship Design and Operation*, November 16–17, London, UK, 99–109.
- NOWACKI, H. 2009 Developments in marine design methodology: Roots, results and future trends, *Proceedings, IMDC 2009*, Trondheim, Norway, Tapir Academic Press, **1**, 47–80.
- PRAETORIUS, G., KATARIA, A., STYHR PETERSEN, E., SCHRÖDER-HINRICHS, J.-U., BALDAUF, M., AND KÄHLER, N. 2015 Increased awareness for maritime human factors through E-Learning in crew-centered design, *Proceedings, Procedia Manufacturing, 6th International Conference on Applied Human Factors and Ergonomics (AHFE 2015) and the Affiliated Conferences, AHFE 2015*, July 26–30, Las Vegas, NV, 2824–2831.
- PRATS, M., LIM, S., JOWERS, I., GARNER, S. W., AND CHASE, S. 2009 Transforming shape in design: Observations from studies of sketching, *Design Studies*, **30**(5), 503–520.
- RAWSON, K. J. 1986 The architecture of maritime systems, *IEEE Proceedings A (Physical Science, Measurement and Instrumentation, Management and Education, Reviews)*, **133**(6), 333–337.
- RITTEL, H. W. J. AND WEBBER, M. M. 1973 Dilemmas in a general theory of planning, *Policy Sciences*, **4**(2), 155–169.
- ROTHBLUM, A. 2000 Human error and marine safety, *Proceedings, National Safety Council Congress and Expo*, October 16–18, Orlando, FL, **7**.
- SCHÖN, D. 1983 *The Reflective Practitioner*, New York, NY: Basic Books.
- SEVALDSON, B., PAULSEN, A., STOKKE, M., MAGNUS, K., AND STRØMSNES, J. 2012 Systems oriented design in maritime design, *Proceedings, The Systems Engineering in Ship and Offshore Design Conference*, March 28–29, London, UK, The Royal Institute of Naval Architects.
- SIMON, H. A. 1969 *The Sciences of the Artificial*, Cambridge, MA: MIT Press.
- SIMON, H. A. 1973 The structure of ill structured problems, *Artificial Intelligence*, **4**(3), 181–201.
- THE NAUTICAL INSTITUTE. 2015 *Improving Ship Operational Design*, London, UK: The Nautical Institute.
- TIBBITTS, B. F., COMSTOCK, E., COVICH, P. M., AND KEANE, R. G. 1993 Naval ship design in the 21st century, *Transactions—The Society of Naval Architects and Marine Engineers*, **101**, 637–671.
- ULSTEIN, T. AND BRETT, P. O. 2012 Critical systems thinking in ship design approaches, *Proceedings, 11th International Maritime Design Conference (IMDC)*, Glasgow, UK, University of Strathclyde.
- VISSER, W. 2009 Design: One, but in different forms, *Design Studies*, **30**(3), 187–223.
- WILTSCHNIG, S., CHRISTENSEN, B. T., AND BALL, L. J. 2013 Collaborative problem–solution co-evolution in creative design, *Design Studies*, **34**(5), 515–542.