

evt. modelle

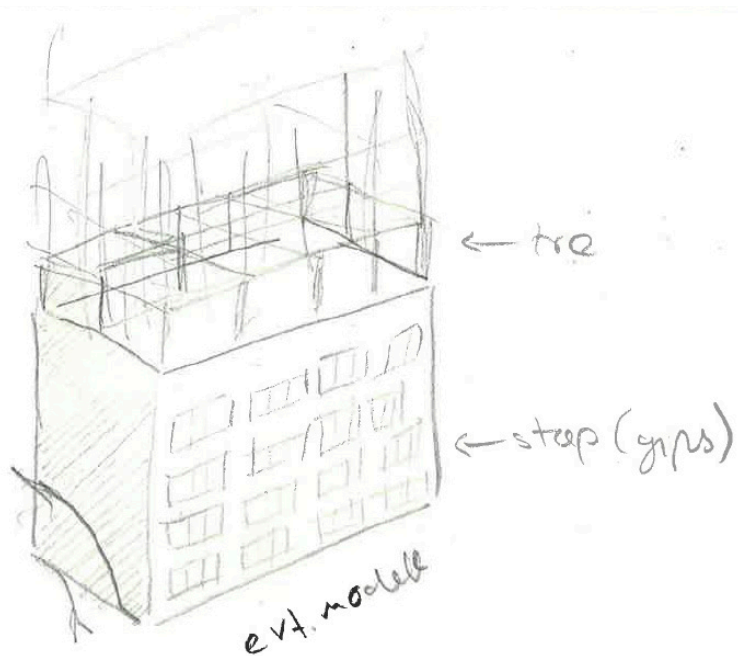



Sketch of small scale model with materials.

On Wednesday (August 19th) I visited Kroloftet and the building I had written about in my pre-diploma. One of the founders, Oscar Honeyman-Novotny, met with me and was really excited about my diploma thesis. He showed me around the building and plot, while enthusiastically explaining his vision for the site.

Kroloftet had signed a lease earlier in 2020, and was just getting started to restore the seemingly vacated

and poorly maintained building. As the makerspace is a non-profit, most of the restoration are to be done by themselves. It will take a lot of effort and time to get the place in shape for the new needs.

The program for Kroloftets previous location will fill up half the space offered in the new location. This made me think of using what's actually happening as the program for my diploma. Half of the volum is still unprogrammed.

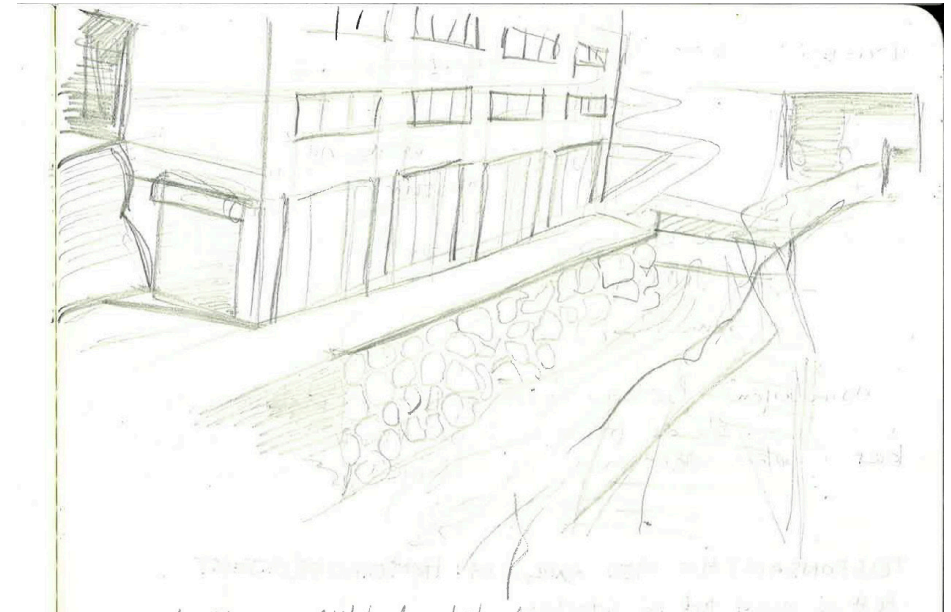

Sketch of how the currently inaccessible facade could be designed and accessed by converting an old sewing cladder construction into a bridge.

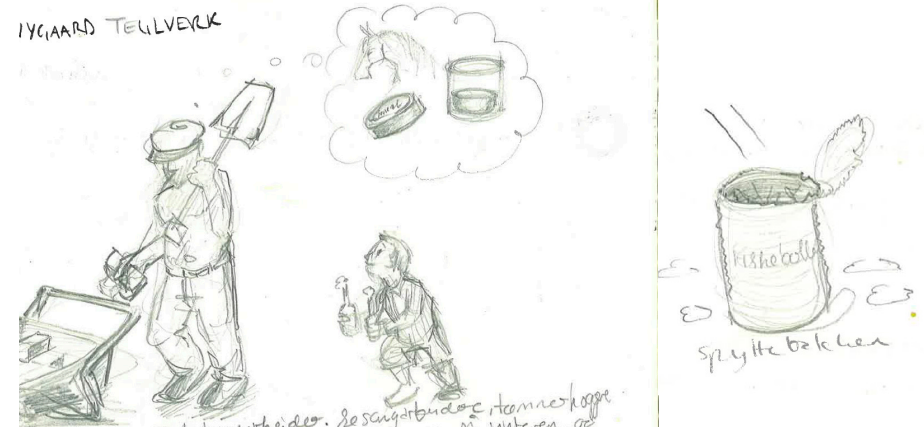
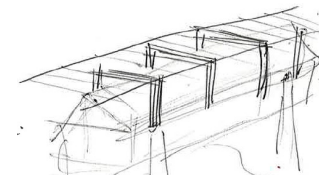

While reading about the history of the plot I sketched how I imagined the life at the old brick factory might have been.

WEEK 35

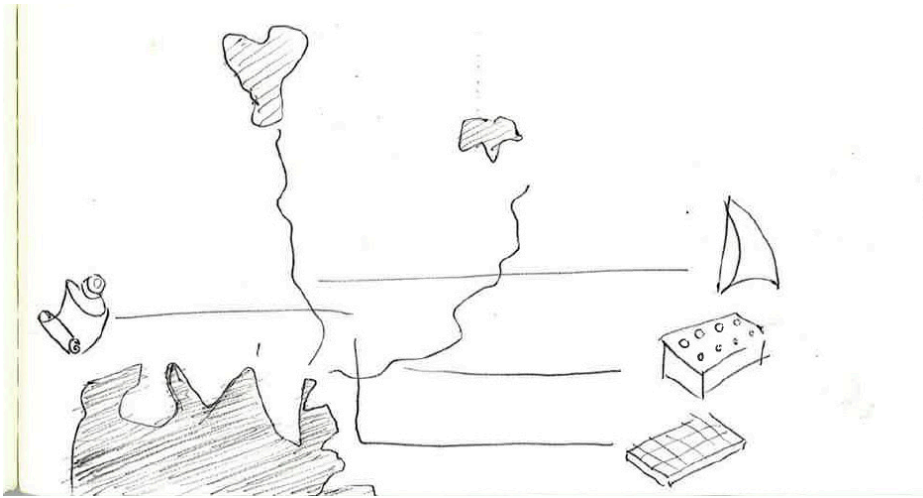

Sketch of a map of Oslo and its previous production facilities.

BYGNINGSNØ	NÆRING	BYGGTYPE	BYGGSTAT	BYGGEAR_2	adresse	Eiendot
95 01501181	Industri	Transformatorstasjon	Tatt i bruk	1993	BJERKEBAKKEN 42	27742
96 02075502	Industri	Transformatorstasjon	Tatt i bruk	1976	BJERKEBAKKEN 66A	271547
97 01831882	Industri	Korridor- og adm bygnin	Tatt i bruk	1993	BJERRINGBAKKEN 7	197822
98 060914547	Industri	Transformatorstasjon	Tatt i bruk	1984	BJØRN BONDES VEI 41	191112
99 060914555	Industri	Transformatorstasjon	Tatt i bruk	1988	BJØRN BONDES VEI 139	191112
100 060949553	Industri	Transformatorstasjon	Tatt i bruk	1905	BJØRN LIES VEI 14	169192
101 011633720	Industri	Annen lagerbygning	lgangsettingstll	1999	BJØRNVEIEN 9	186156
102 06726948	Industri	Transformatorstasjon	Tatt i bruk	1975	BJØRNVEIEN 29	271439
103 01256241	Industri	Transformatorstasjon	Tatt i bruk	1993	BJØRNVEIEN 54	331308
104 01283329	Industri	Transformatorstasjon	Tatt i bruk	1993	BLAKKENS VEI 38	178134
105 01283507	Industri	Transformatorstasjon	Tatt i bruk	1993	BLAKKENS VEI 51	178119
106 06206137	Industri	Transformatorstasjon	Tatt i bruk	1983	BLINDERNVEIEN 4	4688
107 06200090	Industri	Transformatorstasjon	Tatt i bruk	1927	BLINDERNVEIEN 41	4423
108 01425962	Elektrifetets, gass-, damp- og	Garasjehus annek	Tatt i bruk	1996	BLINDERNVEIEN 43	4327
109 01218242	Elektrifetets, gass-, damp- og	Garasjehus annek	lgangsettingstll	1997	BLÅBÆRSVEIEN 38	332912
110 01348755	Industri	Transformatorstasjon	Tatt i bruk	1993	BLÅBØRVEIEN 48	5877
111 01413592	Elektrifetets, gass-, damp- og	Transformatorstasjon	Tatt i bruk	1993	BOGERUDS YNGEN 6	16387
112 01413858	Industri	Annen industribygning	Tatt i bruk	1993	BOGERUDVEIEN 4	16387
113 01834989	Varehandel, reparasjon av mot	Butikkforretningsbygning	Tatt i bruk	1993	BOGSTADVEIEN 1	21412
114 06214220	Varehandel, reparasjon av mot	Annen lagerbygning	Tatt i bruk	1948	BOGSTADVEIEN 6	21417
115 01695164	Elektrifetets, gass-, damp- og	Transformatorstasjon	Tatt i bruk	1986	BOGSTADVEIEN 30B	21437
116 060816596	Industri	Transformatorstasjon	Tatt i bruk	1979	BORGVEIEN 88	40130
117 01683667	Elektrifetets, gass-, damp- og	Transformatorstasjon	Tatt i bruk	1993	BORGVEIEN 9	40223
118 01506573	Industri	Transformatorstasjon	Tatt i bruk	1993	BORGVEIEN 37	7959
119 01414364	Industri	Transformatorstasjon	Tatt i bruk	1993	BRANNFJELLVEIEN 86B	149291
120 01414432	Industri	Transformatorstasjon	Tatt i bruk	1993	BRANNFJELLVEIEN 99K	149253
121 01413916	Industri	Transformatorstasjon	Tatt i bruk	1993	BRANNFJELLVEIEN 112	160564
122 01859728	Elektrifetets, gass-, damp- og	Annen energiforsyning	Tatt i bruk	1993	BRATTVOLLVEIEN 116	1801319
123 01417134	Industri	Transformatorstasjon	Tatt i bruk	1993	BRATTVOLLVEIEN 32A	181049
124 01225435	Industri	Transformatorstasjon	Tatt i bruk	1993	BRATTVOLLVEIEN 219	181872
125 06755716	Industri	Transformatorstasjon	Tatt i bruk	1976	BRATTVOLLVEIEN 219	181872
126 01395963	Industri	Varehus	Tatt i bruk	1993	BROD STABELS VEI 5B	4784
127 06285387	Industri	Fabrikbygning	Tatt i bruk	1939	BREVOLLVEIEN 13	12023
128 01231451	Industri	Transformatorstasjon	Ferdigstøtt	1988	BRENNAGREINDA 41	169324
129 01231575	Industri	Transformatorstasjon	Tatt i bruk	1989	BRENNAGREINDA 27	169340
130 01352958	Industri	Transformatorstasjon	Tatt i bruk	1993	BRISKEBVEIEN 3	2139
131 06082963	Industri	Transformatorstasjon	Tatt i bruk	1980	BROBEKKVEIEN 53C	123179
132 06296002	Industri	Transformatorstasjon	Tatt i bruk	1993	BROBEKKVEIEN 96	122454
133 01827788	Industri	Lagerhall	Tatt i bruk	1993	BROBEKKVEIEN 87	122426
134 01324131	Industri	Annen industribygning	Tatt i bruk	1993	BROBEKKVEIEN 91	12130
135 01827796	Industri	Annen industribygning	Tatt i bruk	1993	BROBEKKVEIEN 100E	122076
136 01271968	Industri	Transformatorstasjon	Tatt i bruk	1993	BRUNAS VEI 89	17853
137 01444641	Industri	Transformatorstasjon	Tatt i bruk	1993	BRUNNEVEIEN 2	59138
138 01820214	Annen eksp. og termin	Tatt i bruk	Tatt i bruk	1993	BRYNSENGFARET 12	1372
139 01820222	Transport og lagring	Annen eksp. og termin	Tatt i bruk	1993	BRYNSENGFARET 12	1372

Hilde Barmen from Cultural Heritage Management (byantikvaren) sent me a list of all industry buildings registered in the cadastre (matrikkelen). I will plot this into a map and see if I find something interesting.

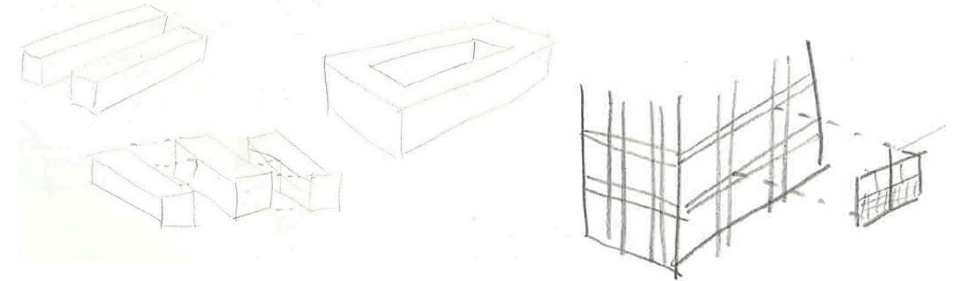

Sketches of different ways to build on roof in the same structural grid as in the building.

Demands for universal design (tek 17) in this building (less than 8 levels):

Two escape routes. One staircase is sufficient if the other route is through a window or balcony. There needs to be space on the ground for a fire truck to drive in and save people from upper levels.

Elevator of 1100x2100. There is one shaft. I'm unsure if it works today.

Insulation. Today the building is uninsulated, and the concrete skeleton is both interior and exterior.

Wheelchair accessibility. There is an elevator in the building for vertical circulation. I've never seen it in use, I don't know if it works. There is currently no way to enter the building with a wheelchair, as the ground floor is raised one meter above terrain. This is only accessible by stairs today.

Bathrooms on each floor. Check.

Ventilation. Currently no ventilation. Is this place too cold for natural ventilation? The parapet inside are pretty tall (1400mm) which makes the space seem more closed and wall-like than necessary. Technical infrastructure could be placed in the floor. This will enable a better connection between the outside and the inside, and also keep the beautiful ceiling structure uninterrupted by pipes.

WEEK 35

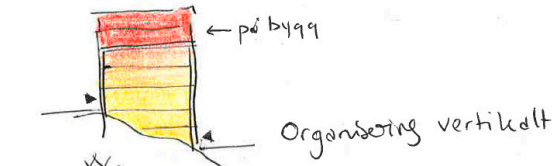

Organisering vertikalt

- felles = åpent (friplan)
- privat = inndelt

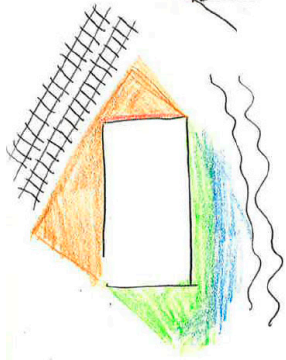

Organisering horisontalt

- stevyside, urban skulptur
- stille, blågrønn skulptur

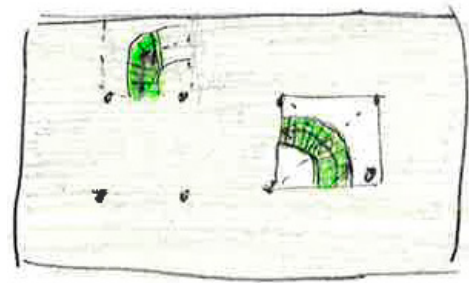
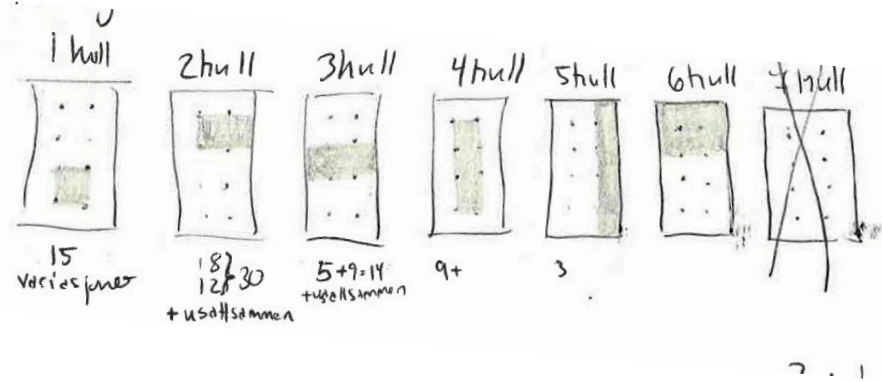

Organisation and circulation.

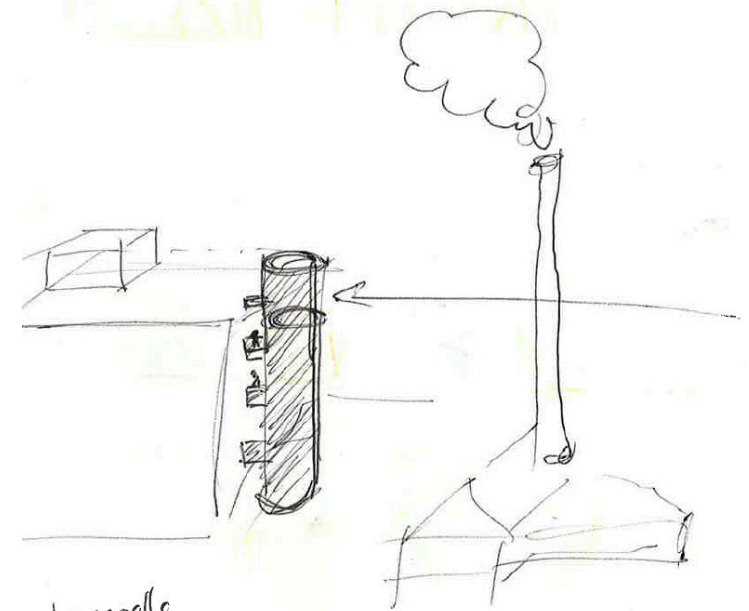
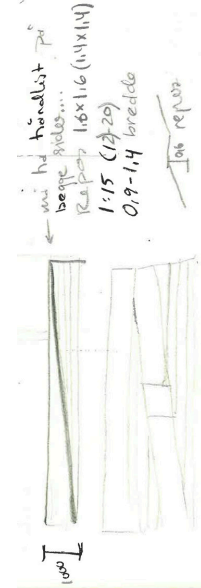

Accessibility and fire escapes.

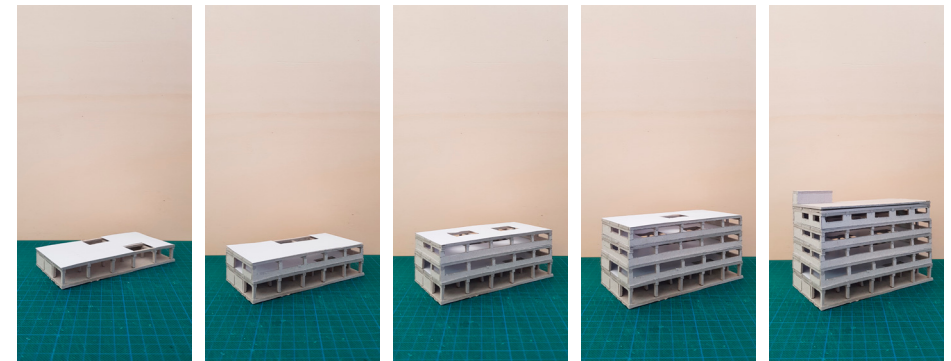

Sketch model 1:200 for studying daylight changes when removing parts of the slabs.

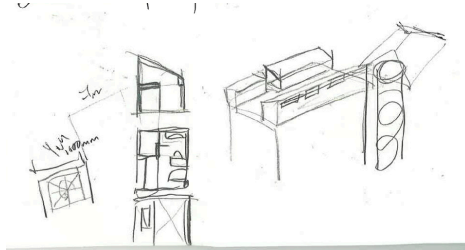

Random ideas.



BOOKER — PAST + PRESENT + FUTURE
MAPS / SITUATION / CONTEXT
CONSTRUCTION / STRUCTURE
PROGRAM
SKETCH BOOK
STORY / HISTORY → tegnererie
UTENOMFORNING - IMPLEMENTATION / DETAILS

Organisation of material.

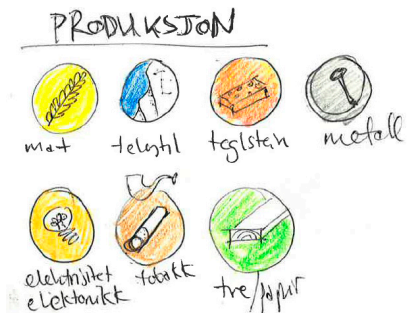

The main production in Oslo during 19th and 20th century from what I have found.

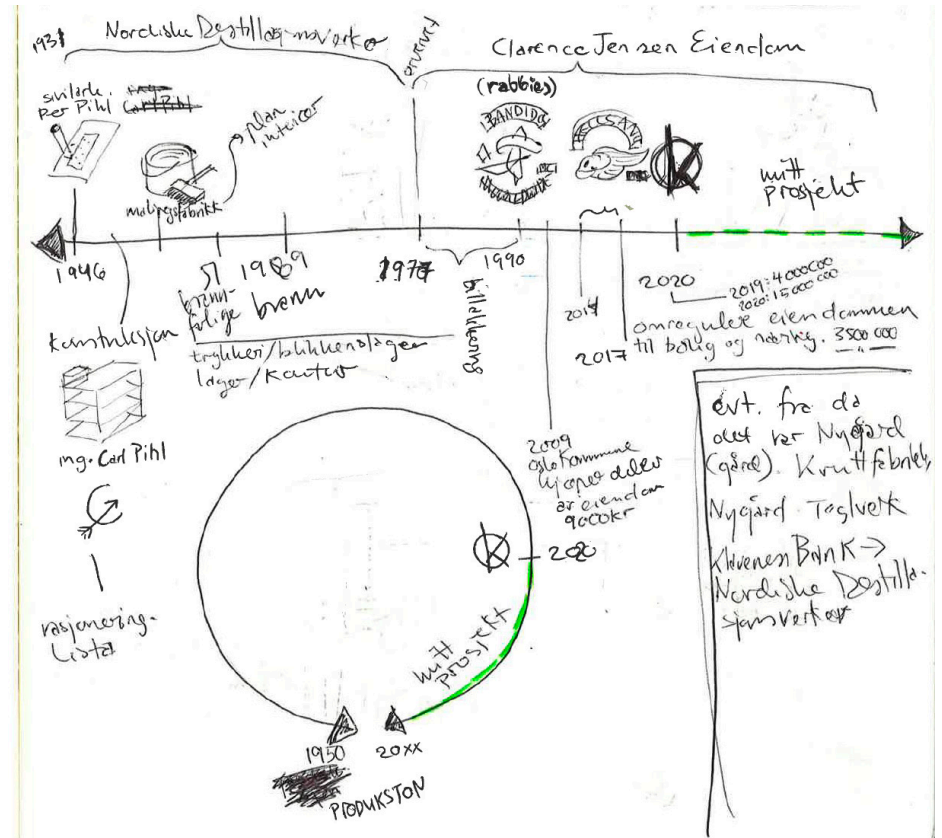

The history of the building, with ownership, usage, leasing. Ways to convey.

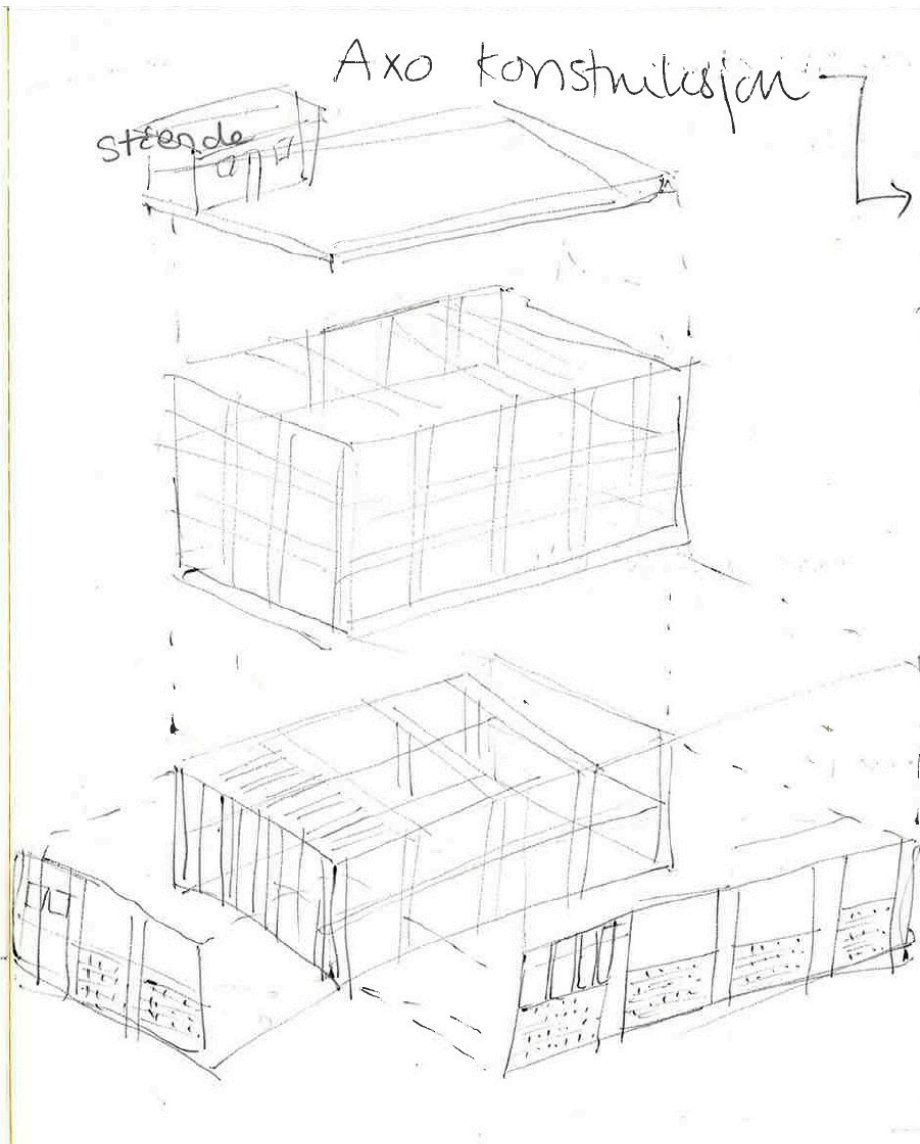

How to explain the construction in an axonometric drawing.

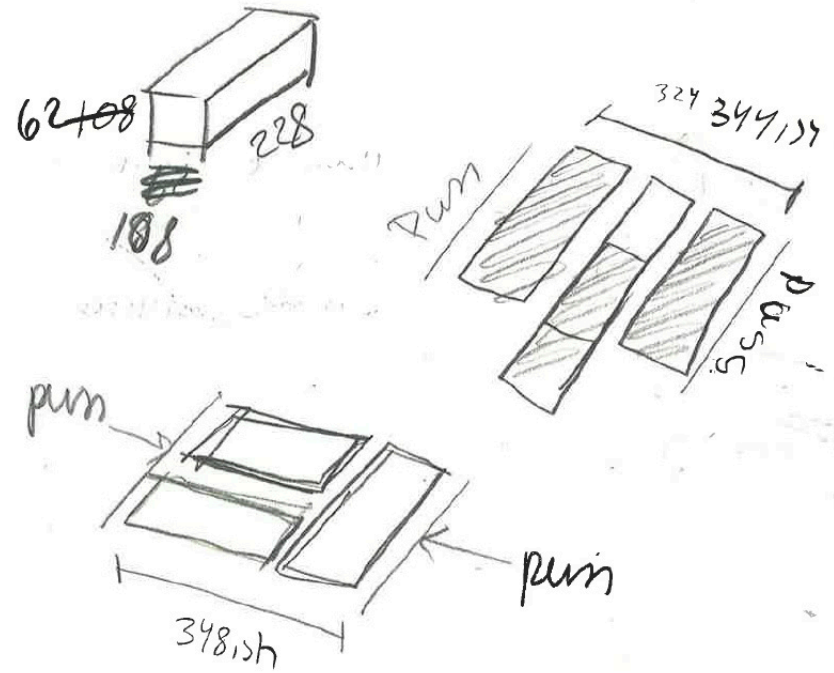

Figuring out the construction and facade.

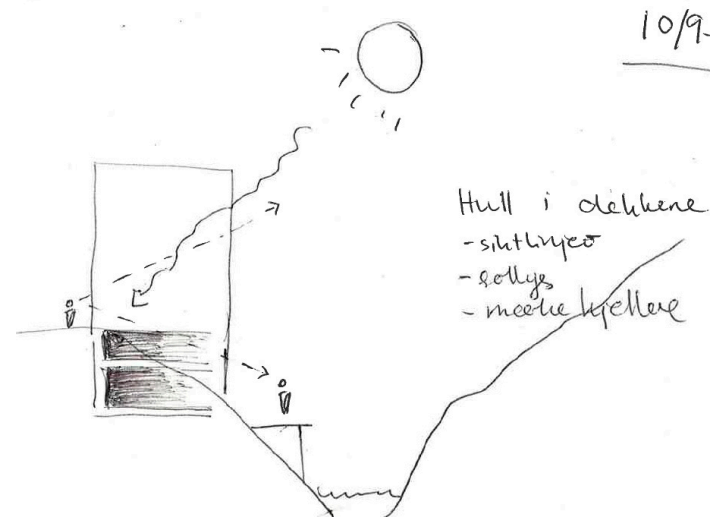

Strategies for making holes in the slabs: sun penetration, sight lines, daylight in basements.

WEEK 37

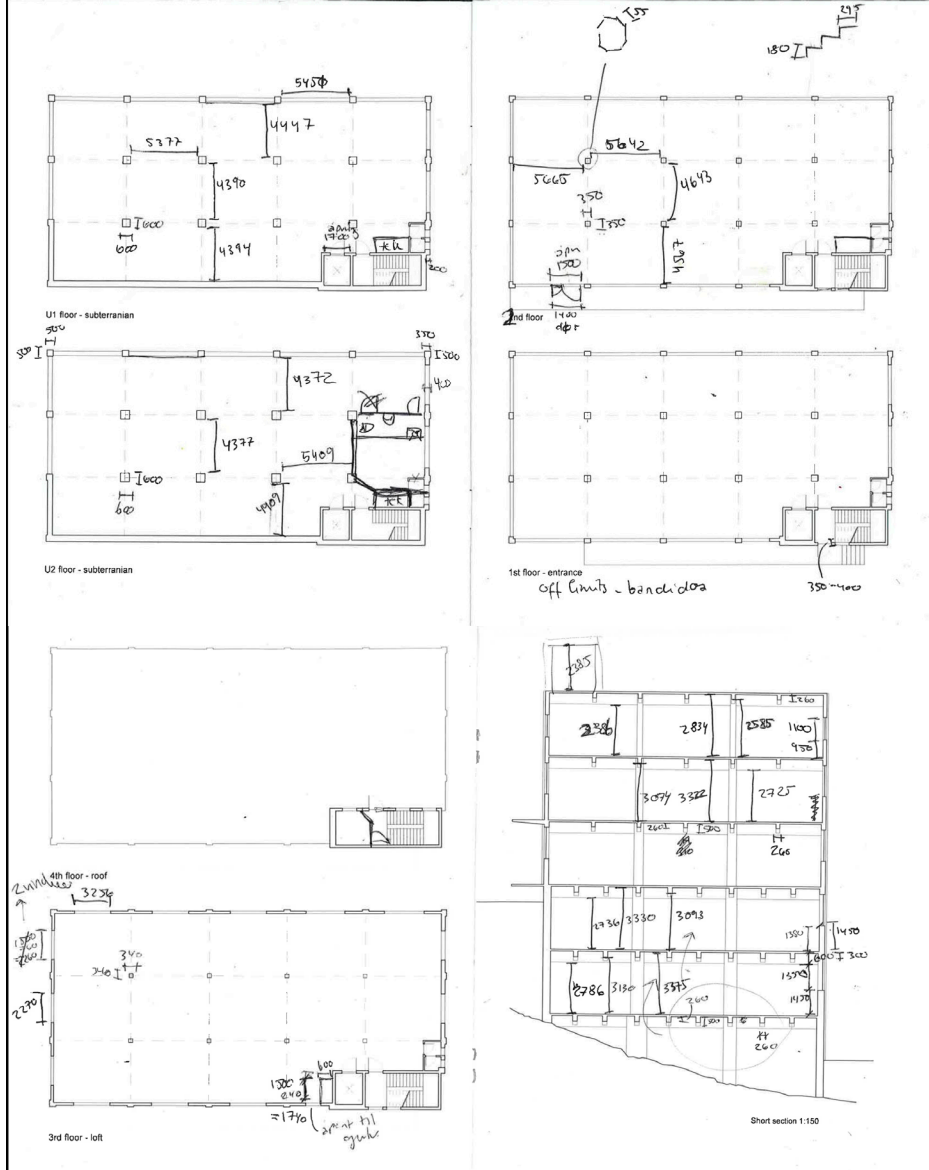

Measurements are way off the original drawings.

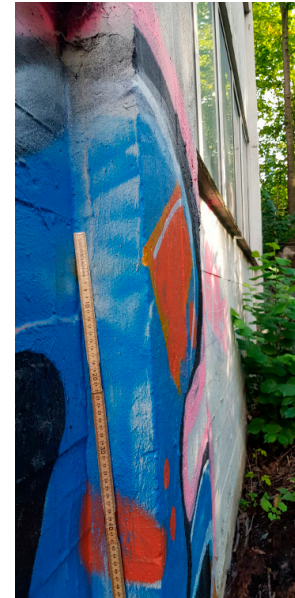
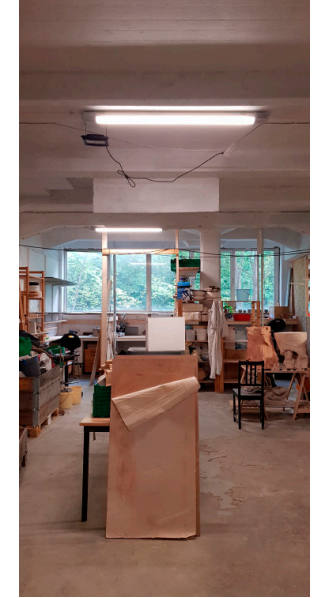

Checking unclear details and odd structures.

WEEK 37

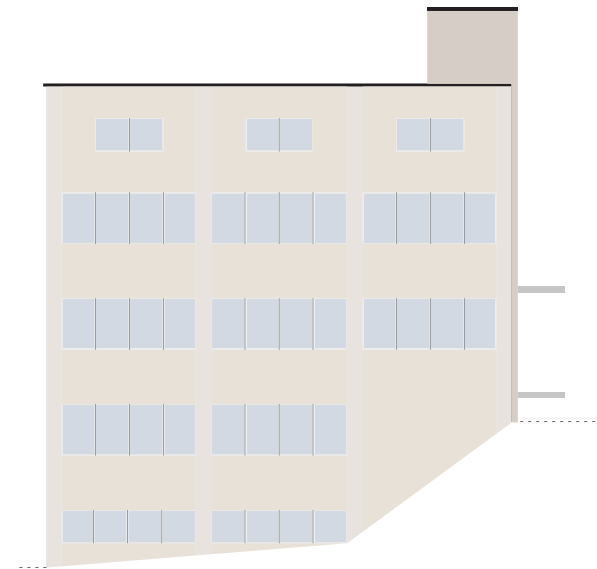
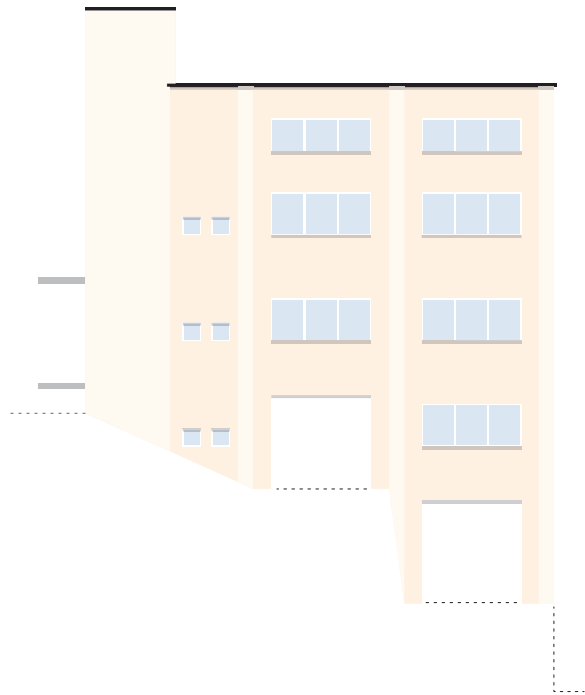
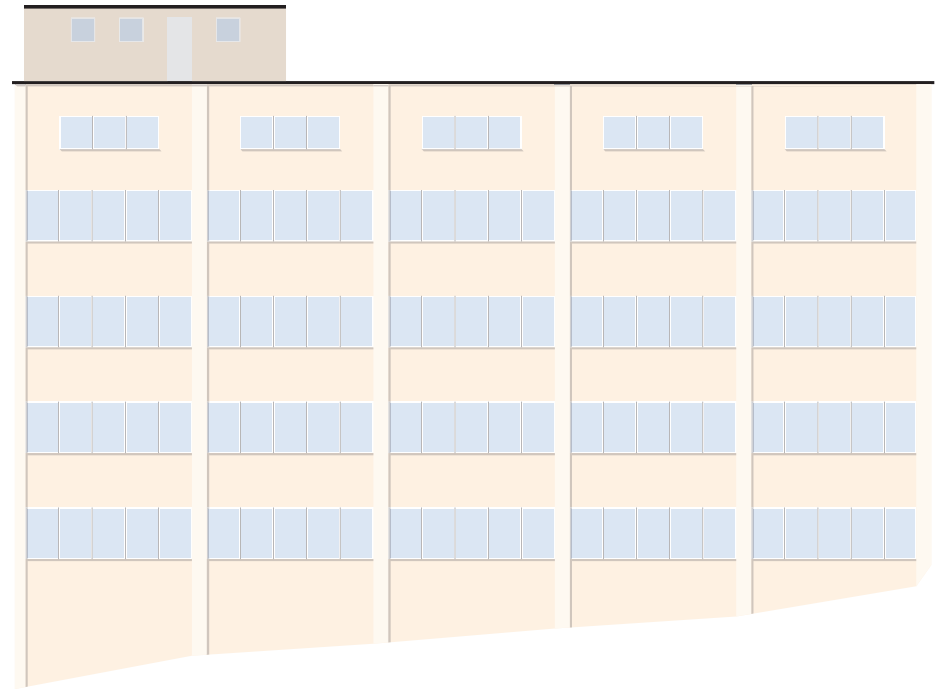
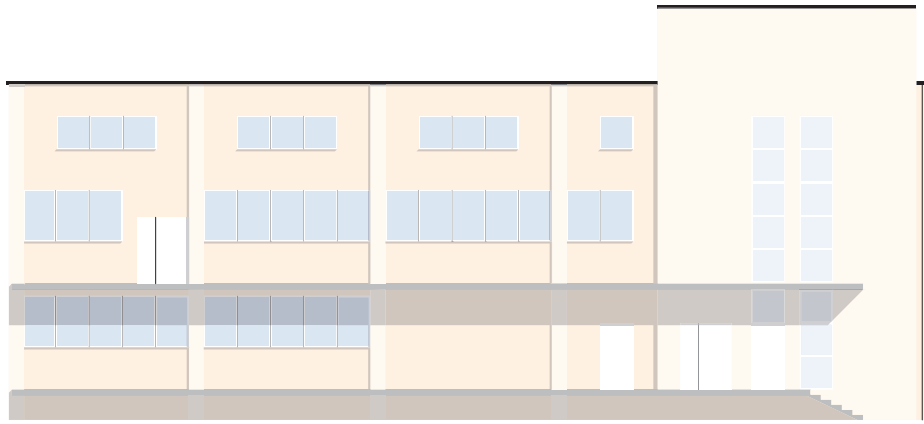



Sketch model 1:50



Site model 1:500

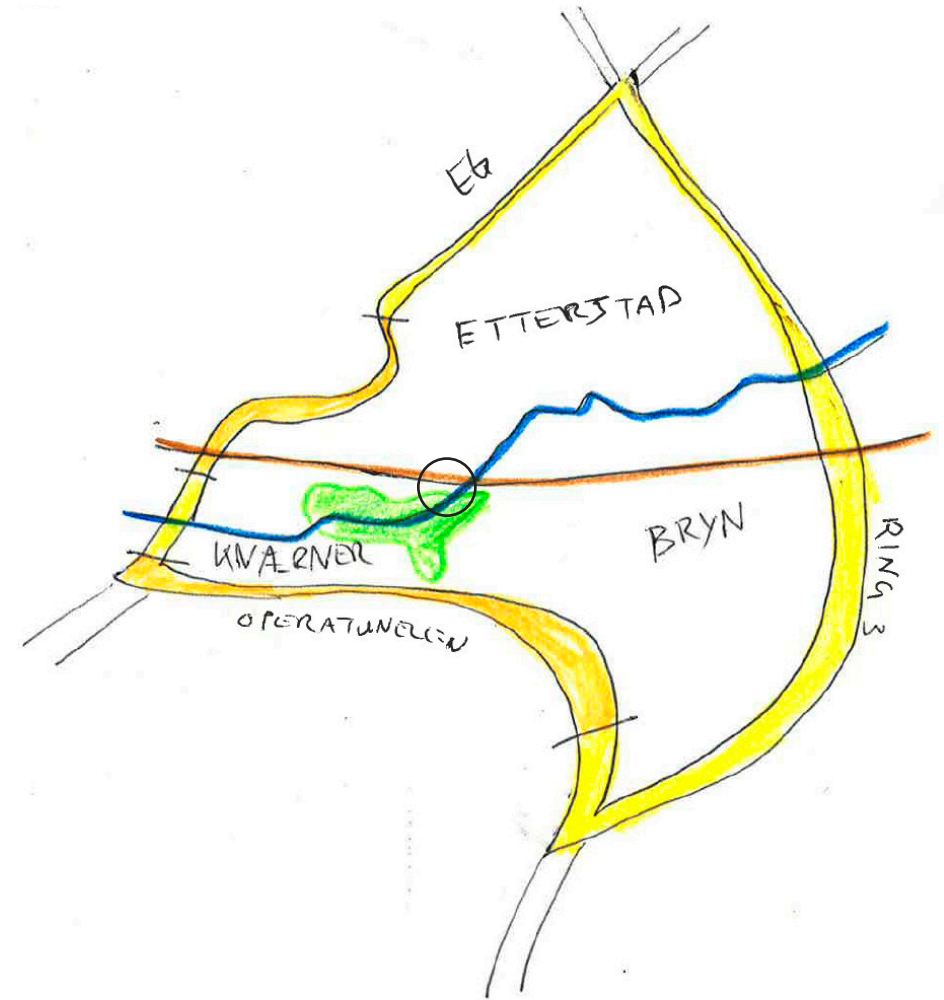

The site is constrained between the railway and the river. This railway was the first to open in Norway, connecting the capital and Eidsvoll, the place where the declaration of independence was designed. Trains are passing by frequently, making this side of the building quite noisy.

The river travels from Alnsjøen in Lillomarka, through Grorud valley before entering the Oslo fjord at Kongshavna. The water flow is small, but due to its waterfalls many of the old industry buildings are placed along this river.

The site marks the entry to Svartdalsparken, the last primeval forest in Oslo. This stretch from Etterstad to Kværner is a popular trail for joggers and baby strollers.

Adjacent fields are the housing areas Kværner, Høyenhall and Etterstad. Etterstad is characterized by lamellas in open grass fields, Høyenhall by single family homes and Kværner by the neoliberal building practice of today. All these areas are constrained by trafficed highways.

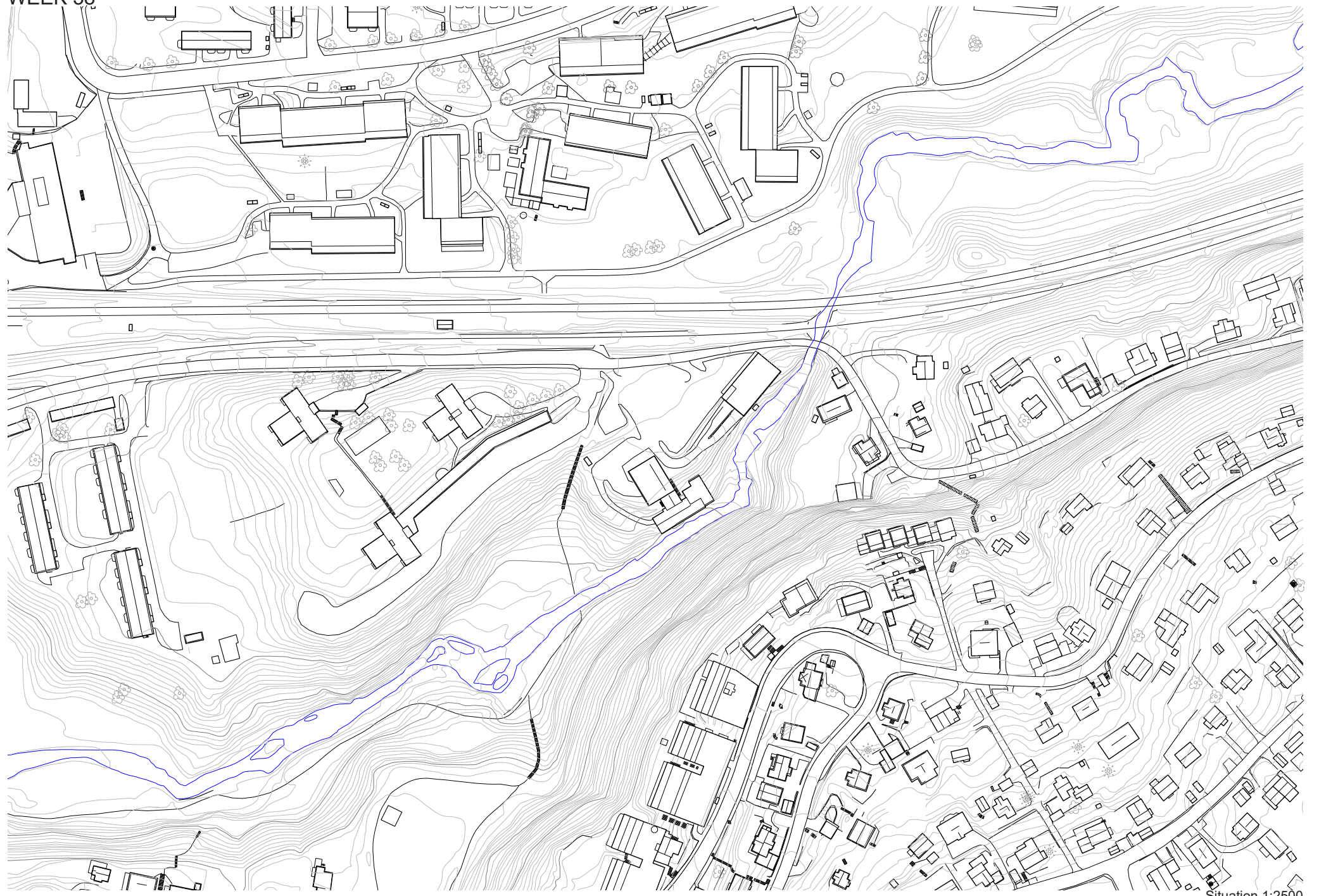

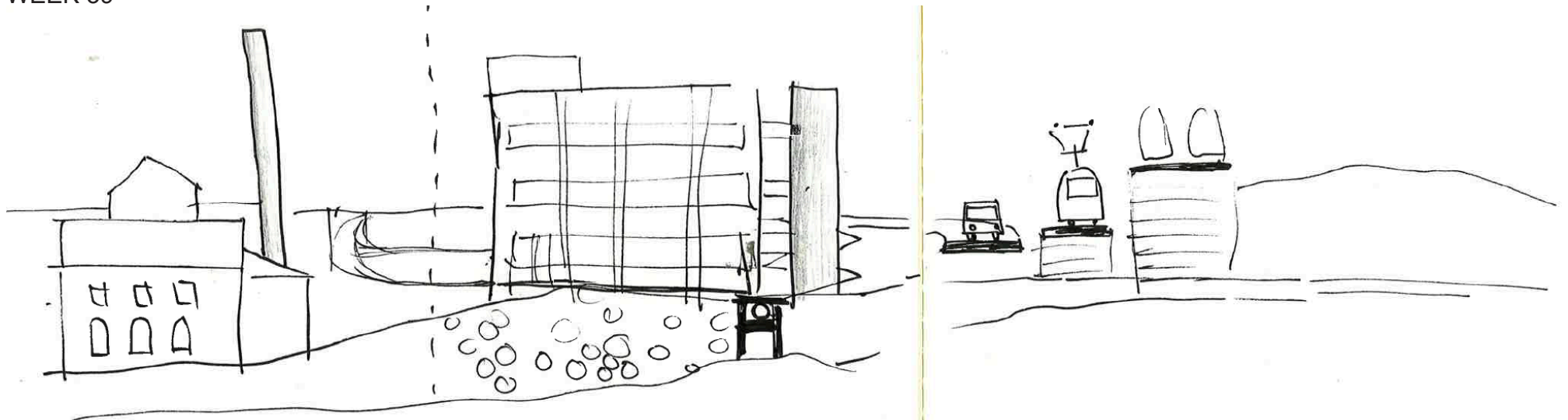

Situation section through the river to see the experience along hiking trail D10. Hight differences, connections, resemblance between old industry chimney and new metal cylinder fire escape.

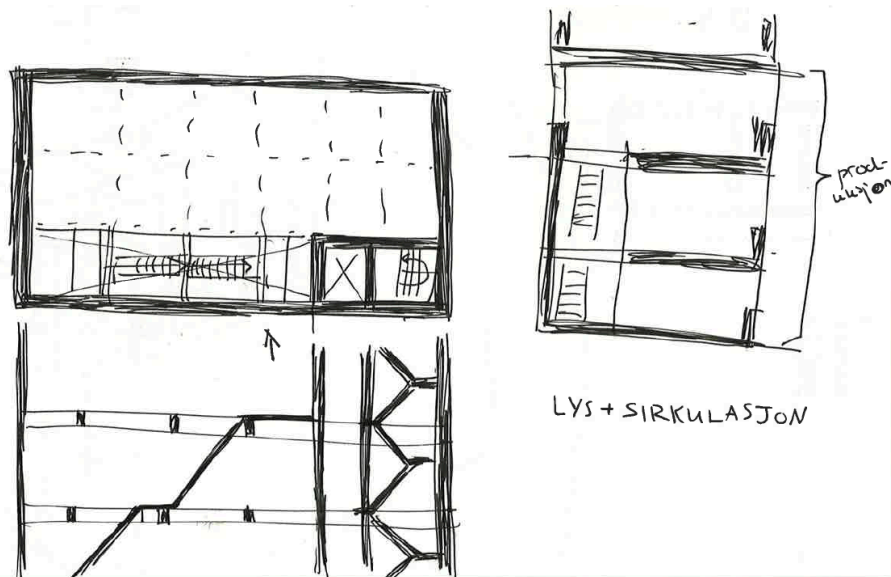

Partly removing the slabs in the basements to allow for daylight and communication.

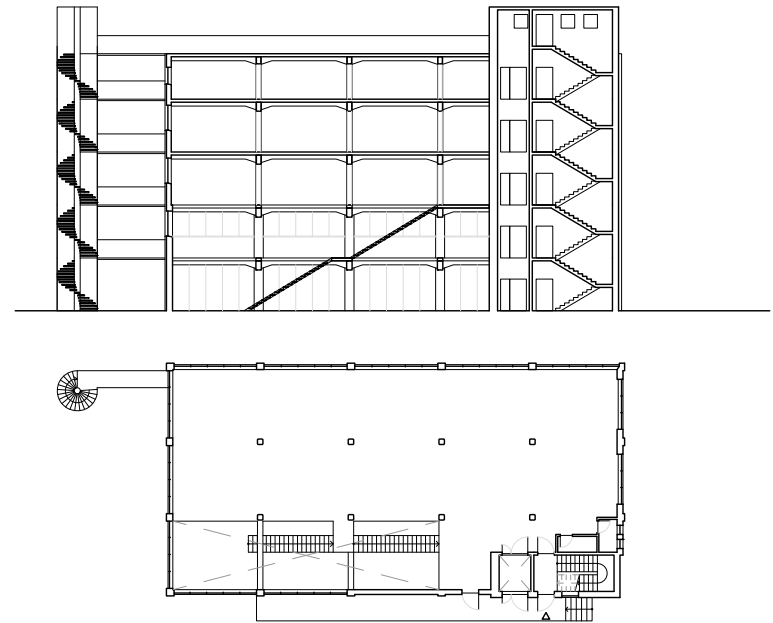

Drawing the same in scale. 1:500.

WEEK 39



Slab between beams removed. I first thought the entire slab was removed and only the beams were kept. But as visible in the pictures the part of the slabs that were resting on beams are kept. It is visible both in the joint and in the concrete tactility.

The connecting bridges can not rest on the beams, as they will end up in the middle of a column. Therefore they are free-spanning.

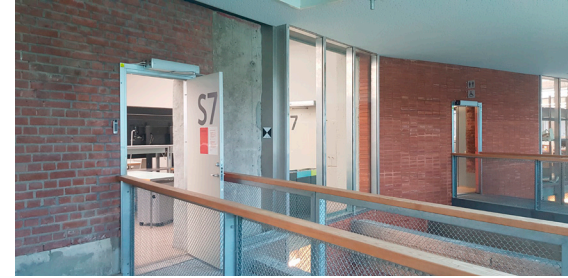

To make space for internal circulation without interrupting the classrooms, a new glass facade is added. The old facade is kept where possible, and new brick are placed where needed. The new brick are connected differently and the joints are colored red.

Some places throughout the building the beams are removed entirely to avoid cold bridges in the concrete skeleton.

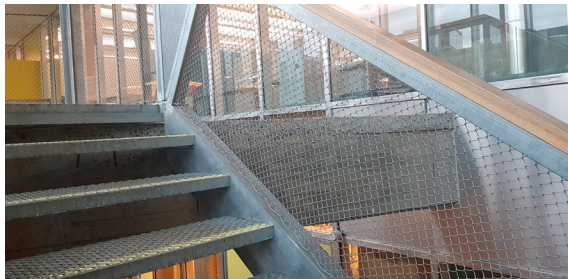
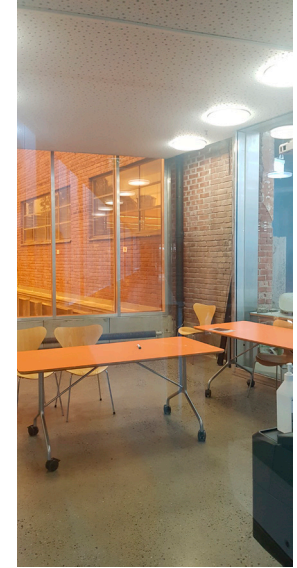

New staircase resting on beam.



Diffusion joint throughout the structure.
Artificial lighting of the structure.

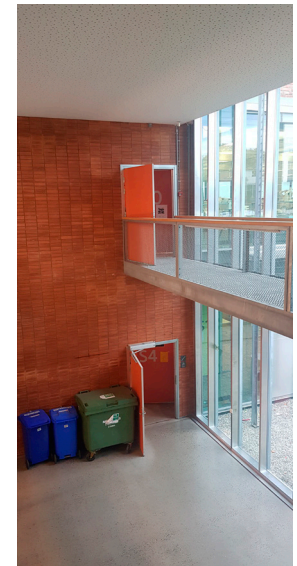

Gathering inspiration from our school, a beautifully transformed old industry building.



Culture

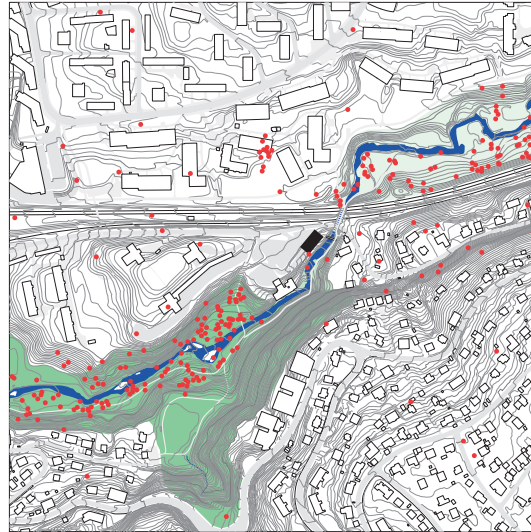

Nature

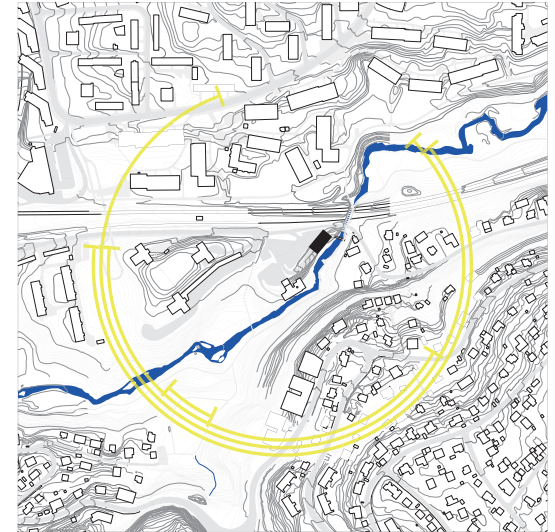

Sun throughout the year

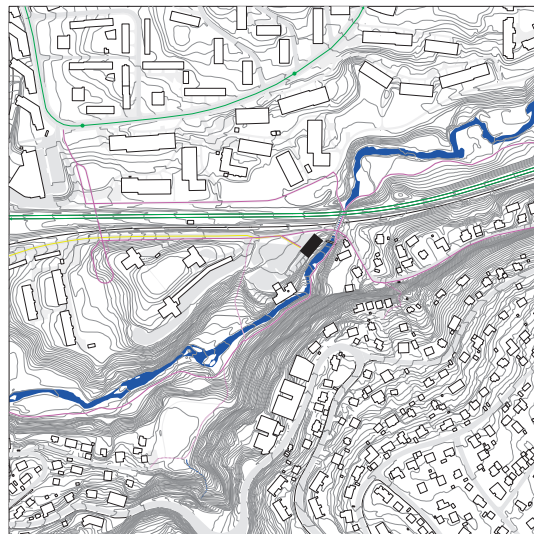

Accessibility

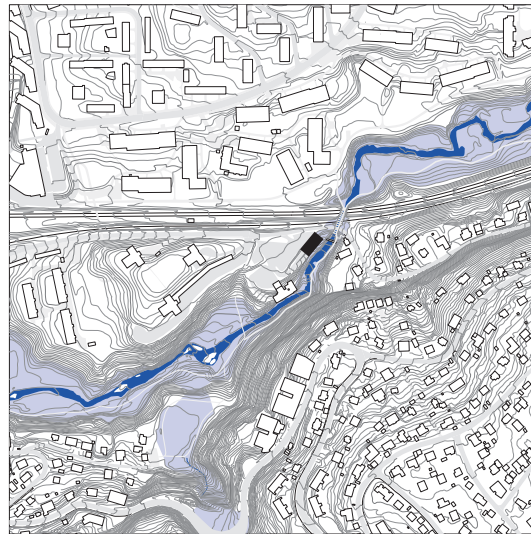

Flood risk

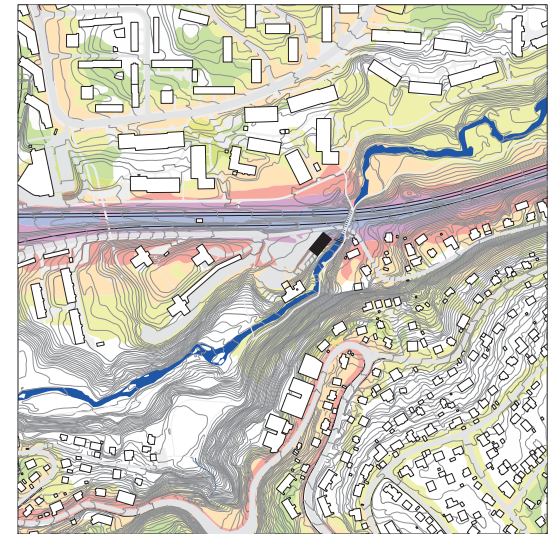

Noise

WEEK 41



The two subterranean floors and the loft are darker than the rest of the building. Too dark for a nice working environment. These can have skylights.

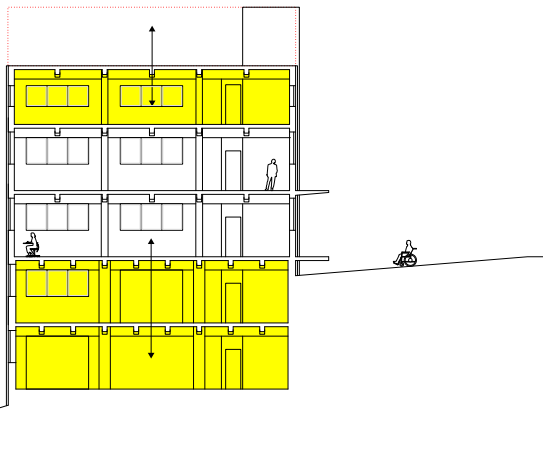

Possible way to bring daylight to the loft.

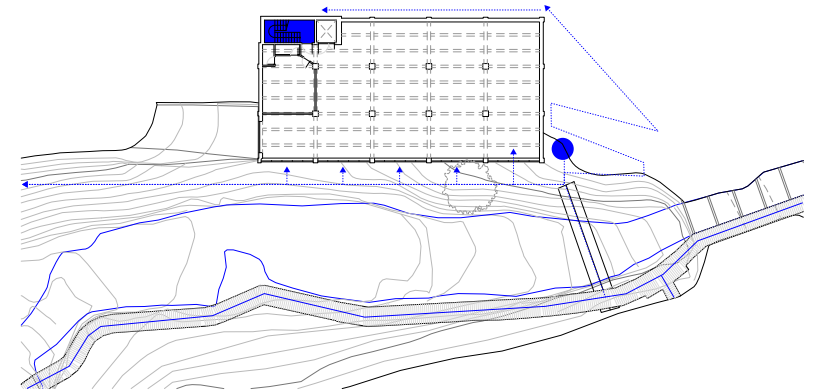
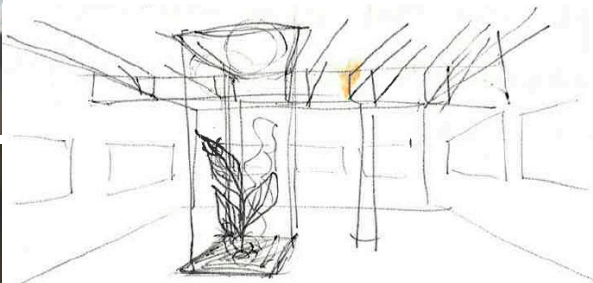

Transforming the water pipe construction into a bridge. Easier access to the building.



Feedback presentation 08.10.20

Take into consideration the current users of Kroloftet. What spaces do they need?
 Emphasise the flexible structure. Show different ways to use the building.
 Sound and heat insulation. Find examples, try out and decide.
 Material studies for the interior. Maybe something warmer to contrast the existing hard surfaces.
 Old buildings don't have the same Tek17 (Norwegian standard) requirements as new buildings.

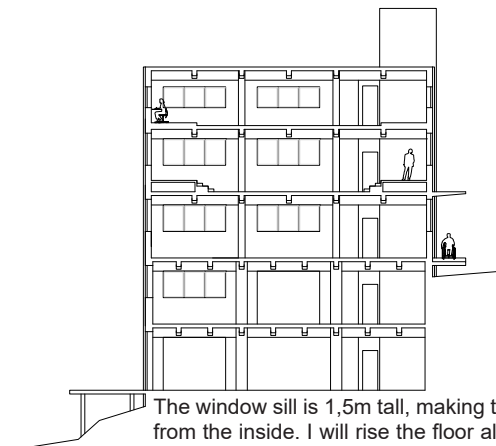

The window sill is 1,5m tall, making the facade seem more like a wall than an opening from the inside. I will rise the floor along the facades for a better connection between the inside and the outside.

WEEK 42

Meeting with building physicist Grete Kjeldsen 13.10.20

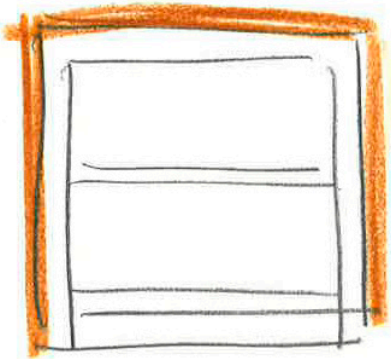

External insulation

This is the most effective option when the facades are not protected. This solution leads to least heat loss. Ex:

Traditional: two-step/ventilated facades. This will make the building blubbier (200-300mm insulation, space, cladding).

Isokalk: slimmer (40-90mm), same appearance. Expensive.

Insulate only skeleton will help a lot as cold bridges are measured in area.

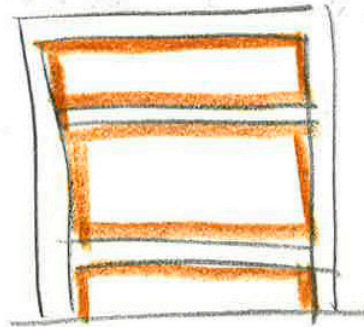
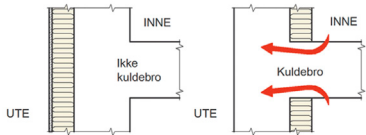

Internal insulation

As the bricks have received heat from the inside since the beginning, they might experience a thermal shock. The exterior surface needs to be treated with a dense layer to prevent water from freezing on the bricks as this will break them. Ex:

Traditional: Lining of steel uprisings and mineral wool. No more than 100mm insulation to prevent brick shock.

Multipor: keeps the plastered facade. Equivalent to 100mm mineral wool.

Wood cement boards: Organic, but covered with enough sealant to avoid rotting. Plastered expression.

Foamglass: Expensive and clumsy. Vapor tight insulation from recycled glass.

Leca facade block: one part leca and one part mineral wool. 125mm.

Vacuum insulation boards: Can't hang stuff on the wall.



Internal insulation

- + Easier (no need for scaffolding)
- + Cheaper (less insulation)
- + Better acoustics inside building
- + Keeps rough and slim exterior

- Lower ceiling height
- Original interior covered
- Still heat loss



External insulation

- + Minimal heat loss
- + Does not affect interior space

- Blubby appearance
- Less daylight

WEEK 42

Meeting with building engineer Finn-Erik Nilsen 13.10.20

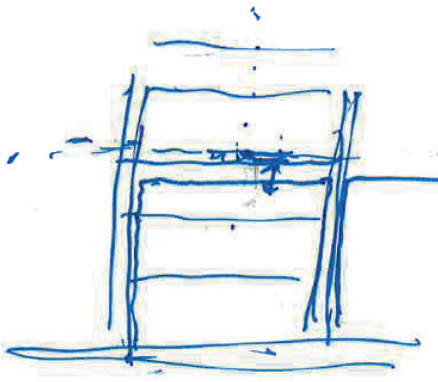

No problem to cut in the slabs as long as it still works as a stiff/rigid slab. Don't take out too many.

The holes should have a distance from the beams as I don't know the exact building statics and torque.

The secondary beams have no significant functions when removing the slab. Can be removed.

Better with circular holes statically.

No problem to build a light structure on the roof, limited to one story.

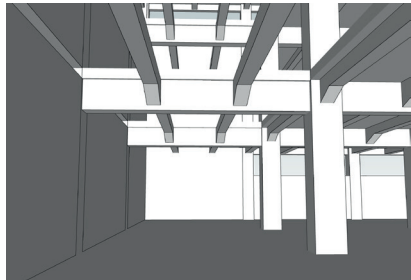

Before meeting

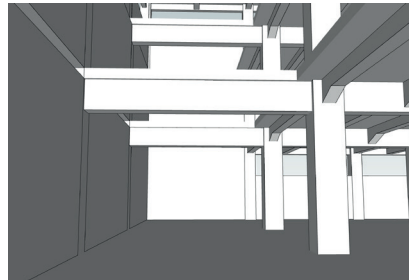

After meeting

Different daylight in basement throughout the year

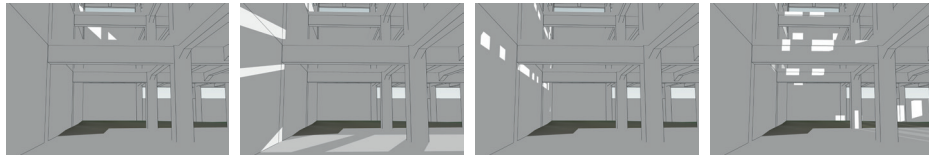

Mars 20th at 4PM

June 21st at 6AM

Sept 22nd at 9AM

Dec 21st at 2PM

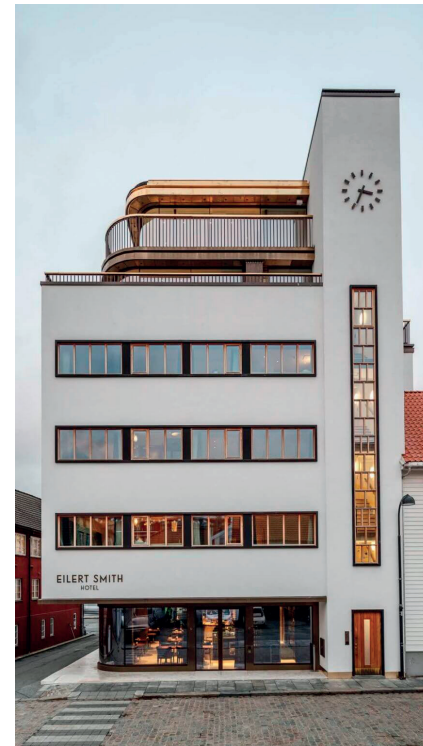

Eilert Smith Hotel (reference)

This hotel and restaurant, opening in 2020, is a transformation project by Trodahl Arkitekter. Previously, it used to be storage space and meeting place for the peasant organization (Bondevirkelaget and Felleskjøpet).

The building shares characteristics with the paint factory at Nygård. It was built in 1937 with a functionalist organization and expression. The stairwell is pulled above the volume to access the roof. Windows in this tower are organized on top of each other, emphasizing the verticality and upward movement. Openings in the rest of the volume is horizontal, while the constructive pillars in the facade rhythmically dividing them.

The most challenging part of the transformation, according to the architects, was to add two more stories without losing the functionalist character of the building. The solution was to extend the stairwell, and make the upper stories pulled in from the facade. The ground floor was then rebuilt to mirror the shape of the roof structure. Materials used are typically for early modernism: travertine; marble; brass; and wood.

For insulation the architects choose 9mm Isokalk on the outside. As visible in the old street views (two upper photos) the facade needed refurbishment. Isokalk keeps the plastered surface and a thin layer is sufficient. This keeps the overall appearance.

WEEK 43

Circulation studies

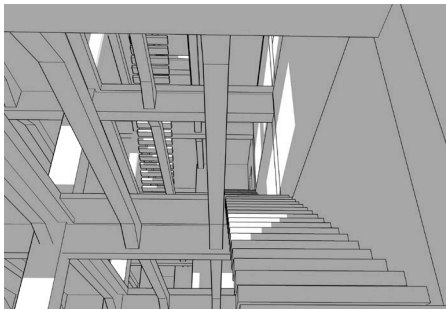
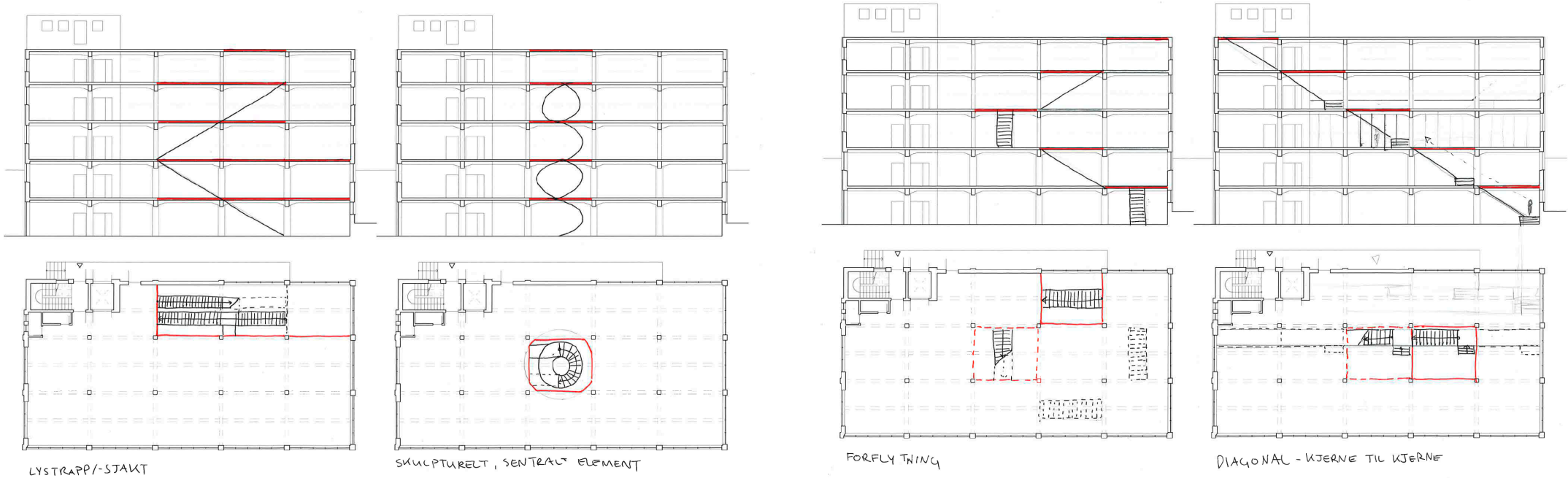

After doing daylight studies in physical model I concluded that removing slabs above the deepest part of the basements would bring most daylight in. By placing the main staircase in this place, the square meters would not be completely lost.

This will make the entire northwestern side of the building into a circulation area, enabling the visitors to watch what's unfolding on each floor without needing to engage.

This solution could also be beneficial for the noise problems from the railway.

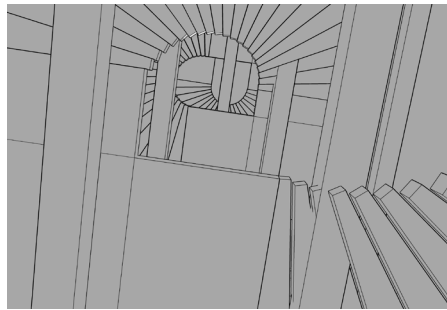

The sculptural spiral staircase creates a slim atrium penetrating the building in the middle. It takes up little space and does not organize the plan. Daylight will only reach a couple of floors down, and do nothing for the basements.



The relocating staircase works perfect with the two main entrances to the building. The movement allows the visitor to always see the staircase, and enter each floor from a different viewpoint.

It takes up more space than the sculptural spiral staircase as it also needs free circulation space inbetween the stairs.

It does not do that much for daylight, but creates interesting visual connections through the building.

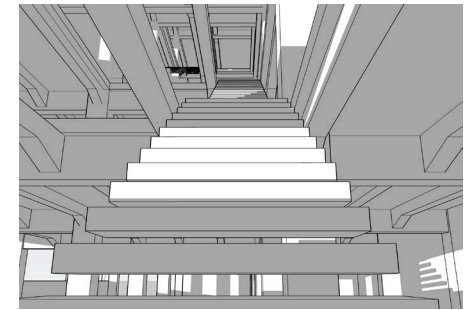

The diagonal staircase runs through the building from one (future) core to another. The plan could benefit from this divided organisation: keeping the windows free for work places; and dividing the lowest floor into a bar and a metal workshop.

When modelling it I found that it was too steep to look as it does in the drawings. It will need to change place going upwards, and will not appear as a string connecting the building to itself.



tem
finer
fls
komigete
spilvater

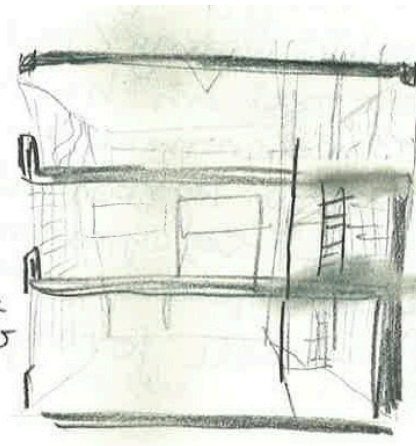

Vi trenger / bruker faktisk
de samme Materialene.



-  Food production
-  Individual production
-  Individual production
-  Lightweight workshop
-  Wood workshop
-  Metal workshop

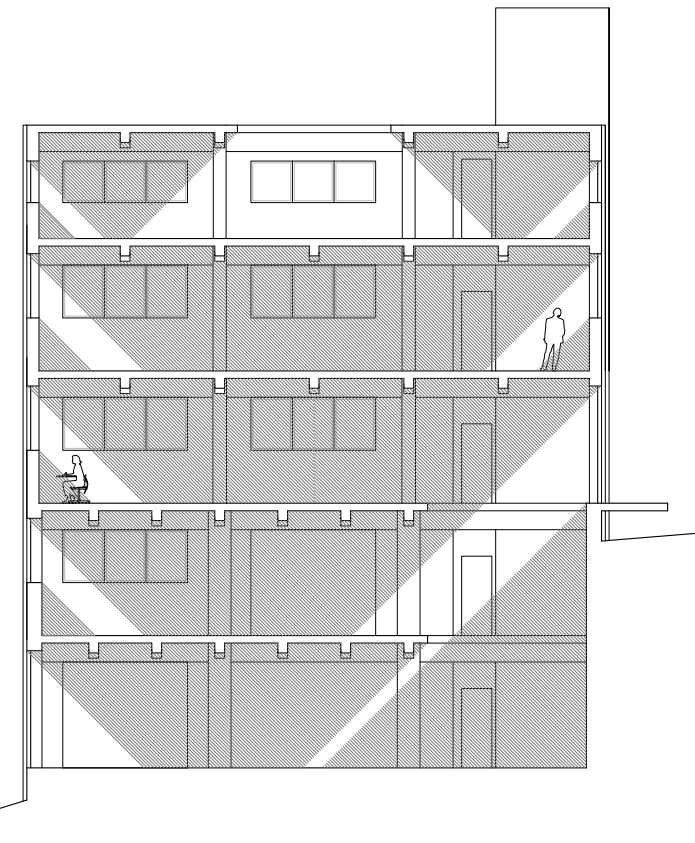

WEEK 43

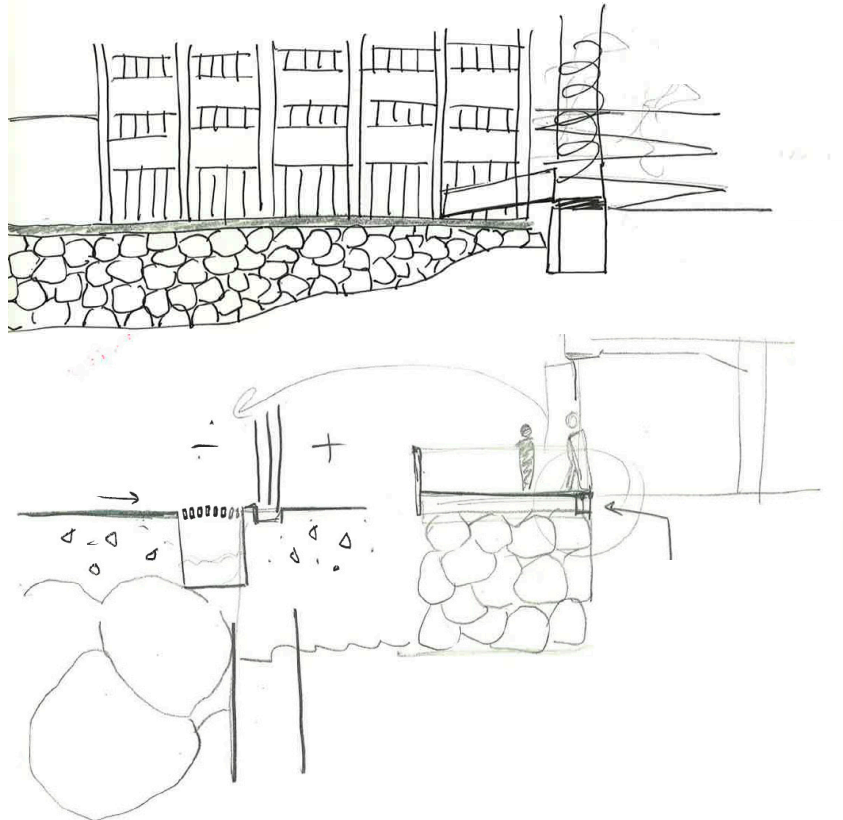

Sketching how the entrance can be designed. Parts of the slope is today covered with stone, probably from the building process. May be the concrete top can rest on stones? Concrete because of flood risk and because of interior concrete: seamless from indoor to outdoor. Both concrete and natural stone works good for drainage.

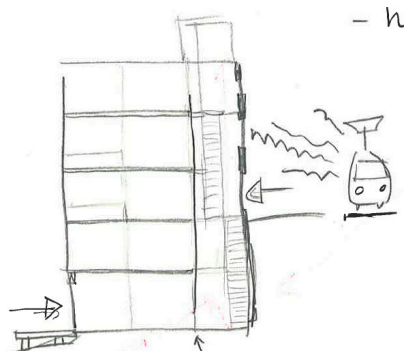

Sketch of how the light shaft/diagonal staircase can create a noise barrier.

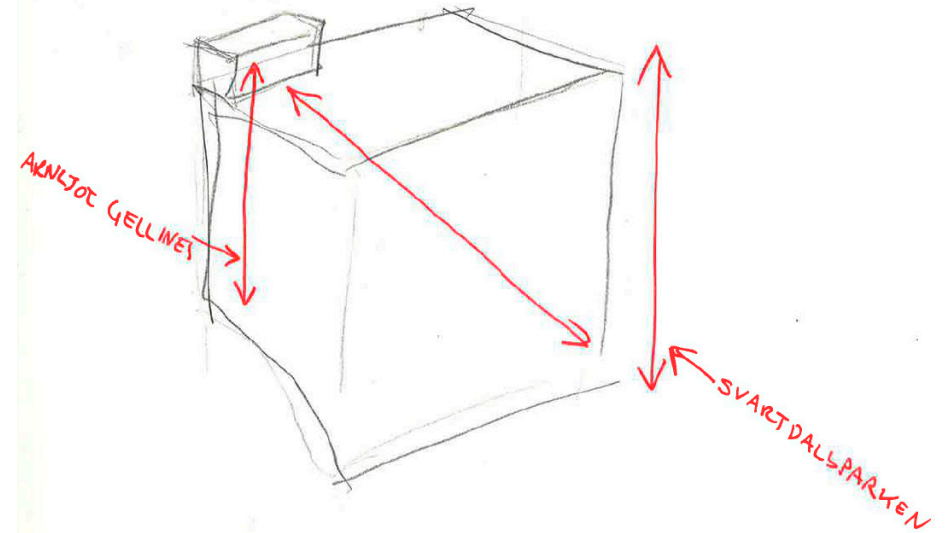

Three staircases: One existing, one exterior fire escape from new entrance, and one interior for exploring the building. Explore in model if it is possible to mix different versions from the circulation studies: The diagonal, the light shaft and the relocating staircase.

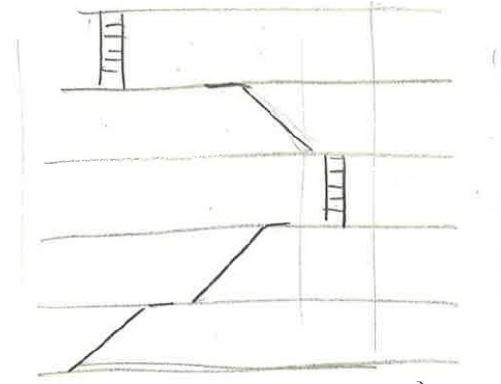

Feedback mid-crit 22.10.20

- Talk with expert on daylight and indoor climate: Arnkell Petersen
- Introduction explains well and fits the program.
- Program chosen is well suited for the building and area.
- What are the strenghts and qualities of the building? What can be added to emphasize this?
- Visitors staircase: spacial experience rather than efficiency. Should go all the way to the roof.
- More focus on materiality.
- Green roof: soil weighs a lot. May have to reinforce the roof. Check load-bearing capacity.
- Biologic diversity in the valley: Oslos only primeval forest.
- History: the pilgrim route goes along the valley, Oslos main access before industrialisation.

WEEK 44

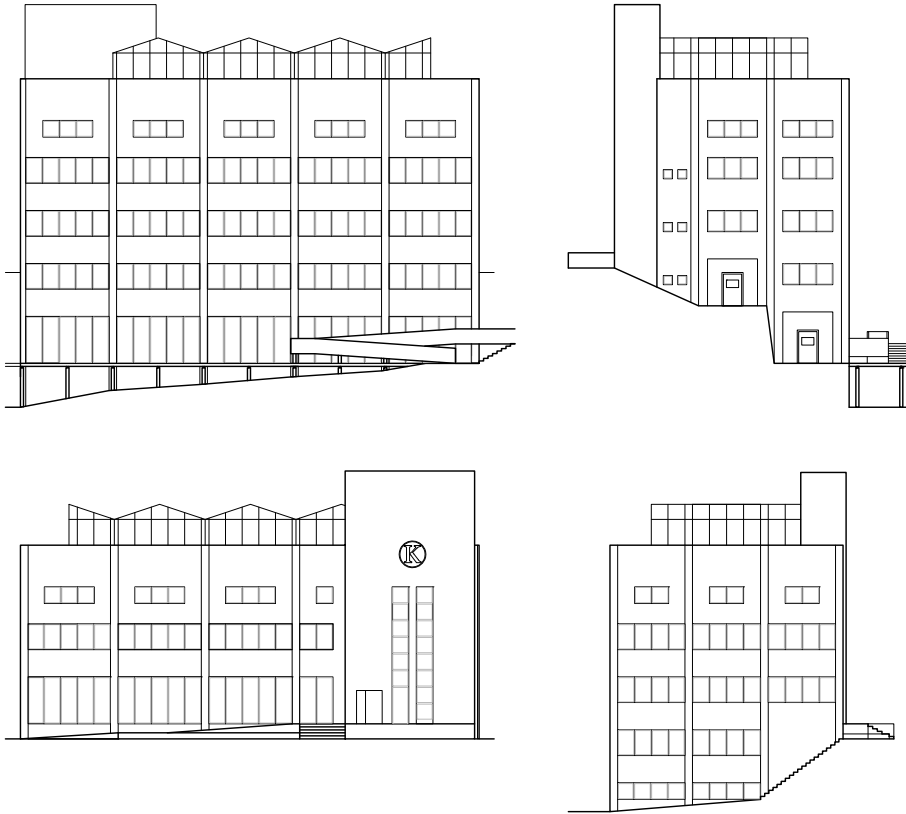

Facades 1:500. Shows new access and food production on roof. The openings in the entrance floors are one story tall. Towards Svartdalsparken the concrete slab rest on pillars to be gentle with the biological diversity. Stairwell is extended to make room for natural ventilation exhaust and technical room. Outer wall "extended" to make up the fence around roof.

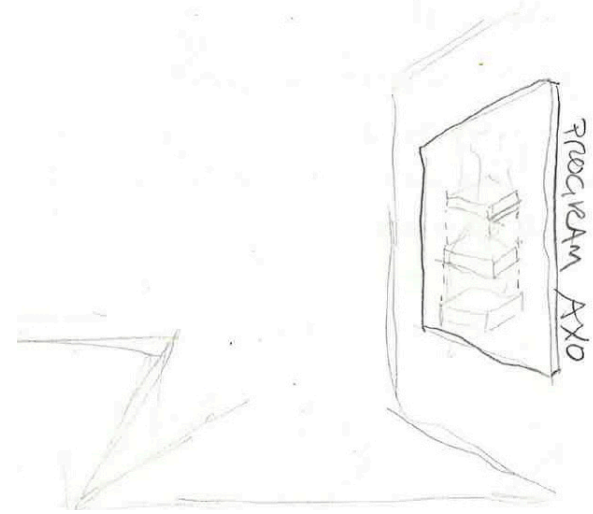
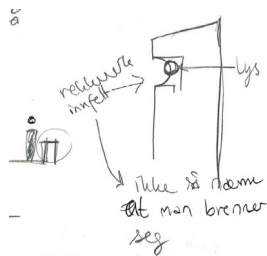

Sketch of main entrance (floor 1). There is no reception, only a board with an axonometric drawing of the different programs unfolding on each floor.

The original building notice reveals that the roof slab is 11,5cm thin. The calculated snow load is half of what we take into account today (300kg/m²). There is no calculation of any person or activity load (nyttelast). The roof might need reinforcement if it is to carry more loads.

<u>Tak</u>	
<u>Plate</u>	
<u>Belasting</u>	
10cm plate	240 kg/m ²
7,5cm surte + tekn. etc.	200
sne	150
	<u>g = 590 kg/m²</u>

WEEK 44

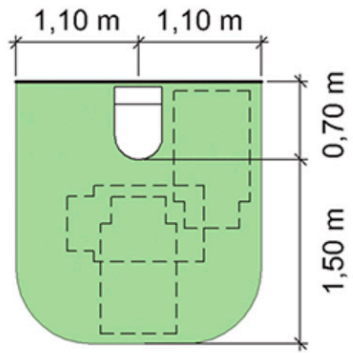

a

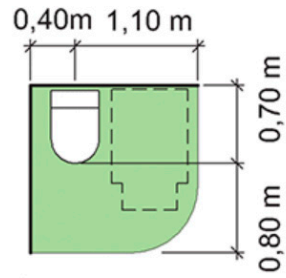

b

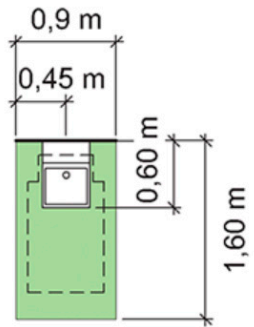

c

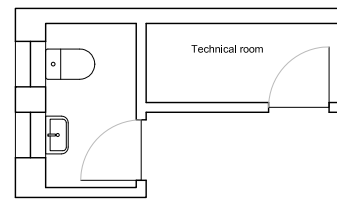

Existing

Existing bathroom does not meet the requirements of one universally designed bathroom on each floor in a public building.

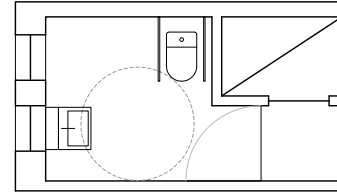

Kjøkken

By making the technical shaft smaller the bathroom can adapt to universal design while still receive daylight. One-sided access to toilet from wheelchair.

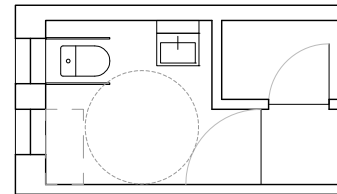

Kjøkken

One-sided access to toilet from wheelchair.

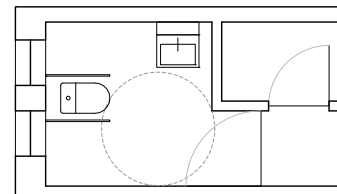

Prøv disse to løsningene. De er de anbefalte på Byggforsk.

Two-sided access to toilet from wheelchair.

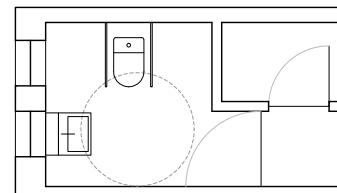

Prøv disse to løsningene. De er de anbefalte på Byggforsk.

Two-sided access to toilet from wheelchair.

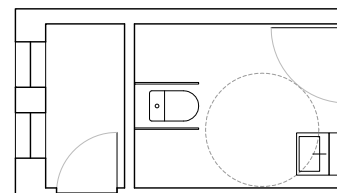

The most space efficient way of transforming these facilities. However, daylight is wasted on a space rarely visited.

WEEK 45

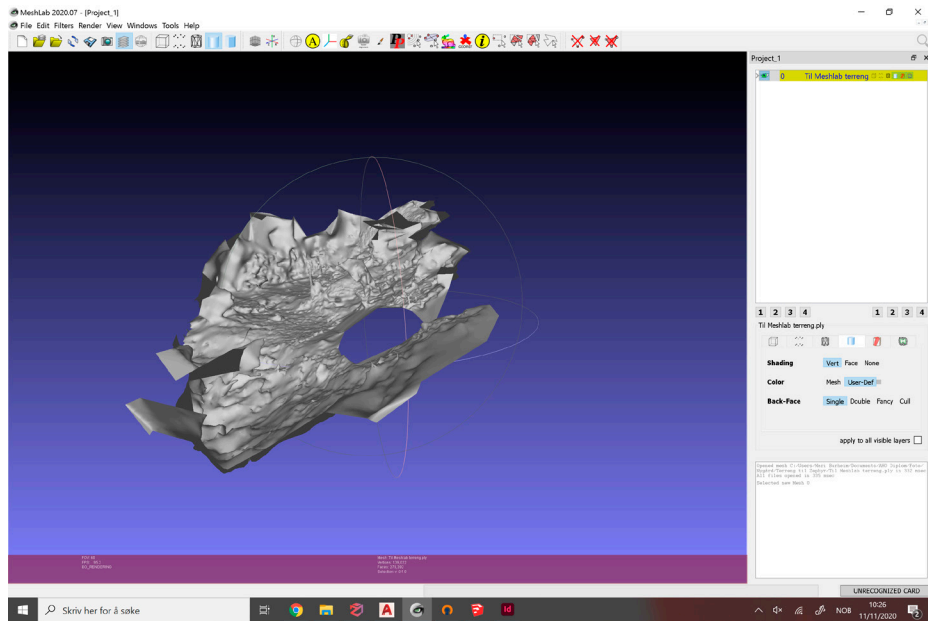
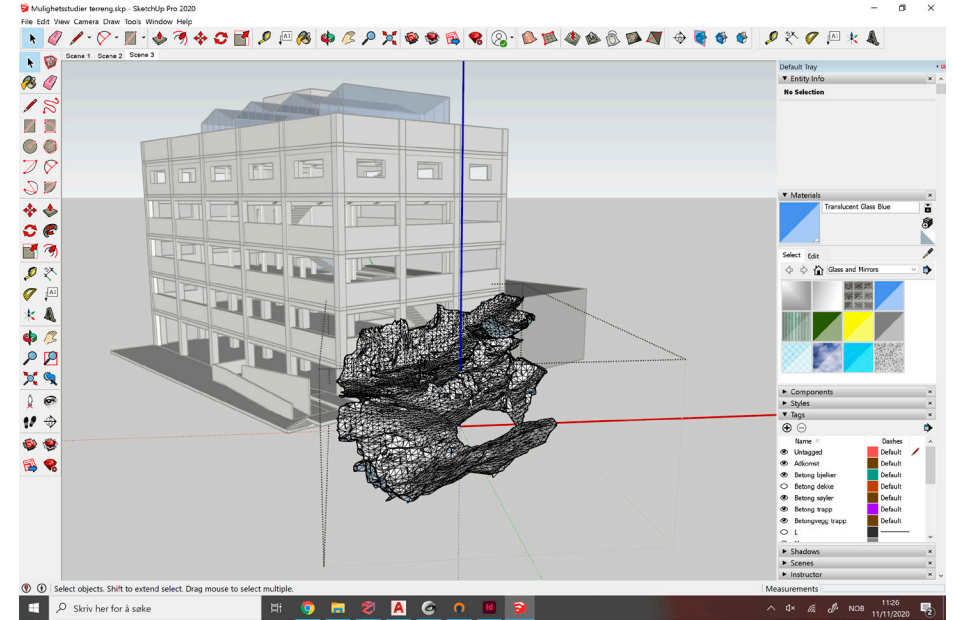
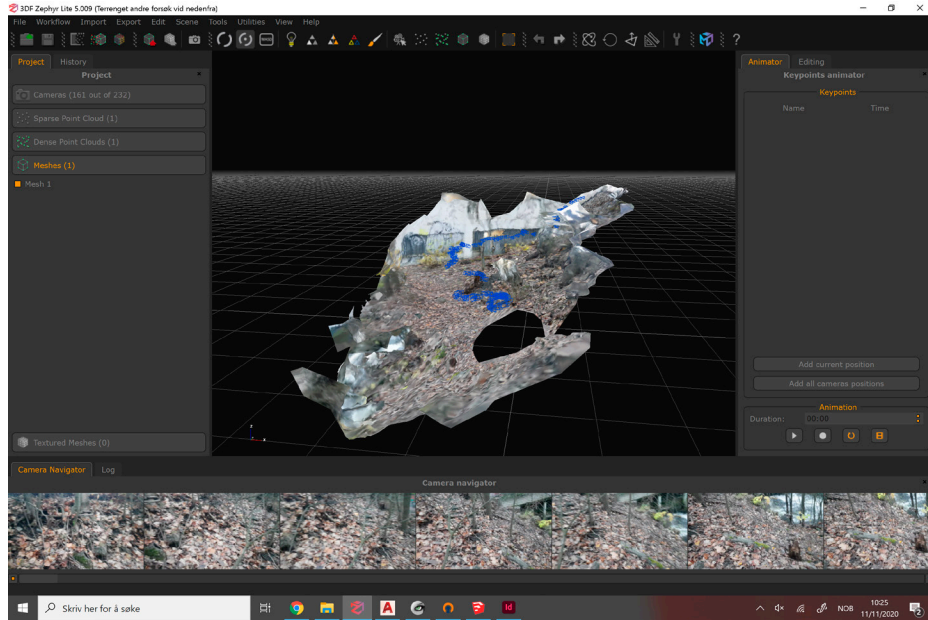

Photogrammetry of the northeastern side of the building. The contour maps from the school and from ArcGIS does not look like the existing terrain.

New (gray) vs. old (pink) contour lines. This will be important when planning the ramp from the bridge (U2) to the entrance floor (1).

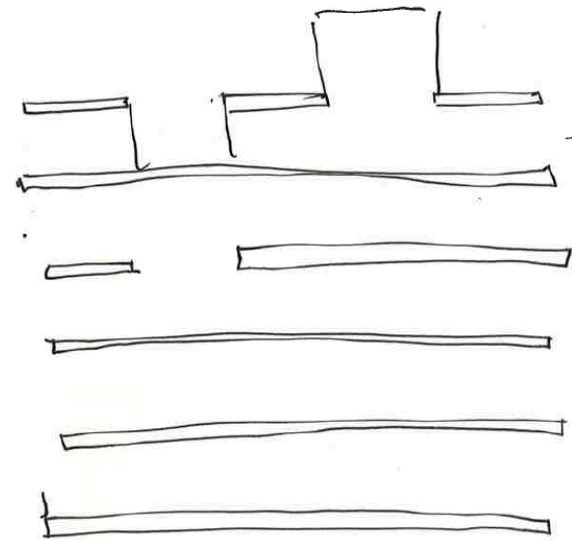
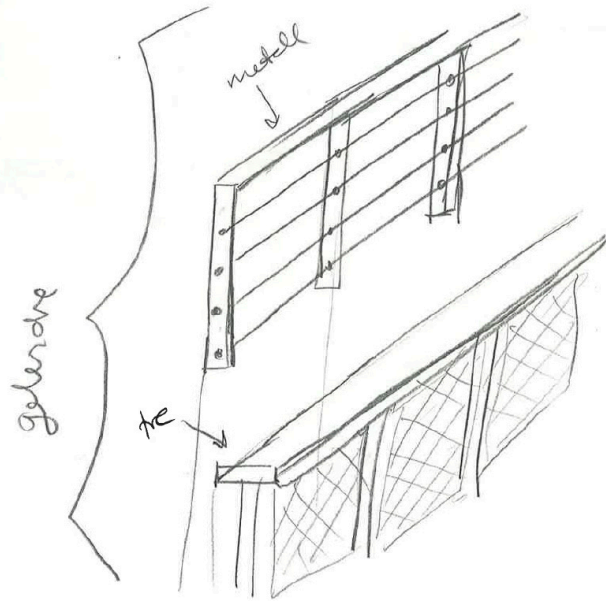

Two openings in the roof?

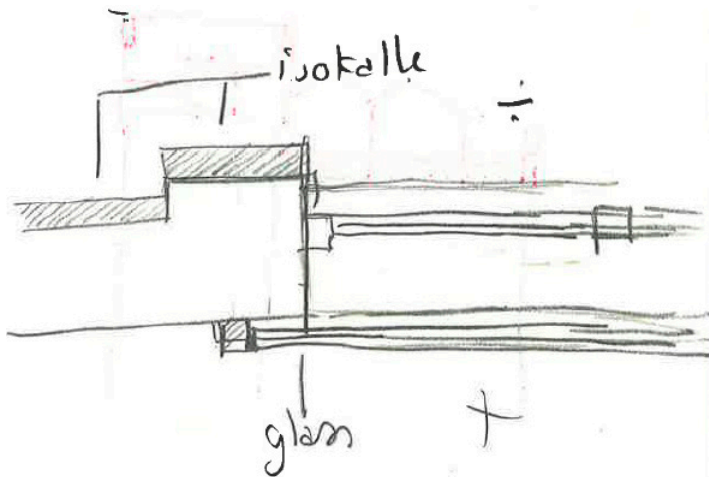

WEEK 46

Meeting with indoor climate expert Arnkell Jonas Petersen 10.11.20

As the beam structure is important for me, the ventilation should be placed somewhere else than in typical buildings, which is in the ceiling.

- All natural ventilation is not appropriate in Norway because of the climate
- Common ventilation: Big box on the roof collects and heat up air. Sends it down to each floor. Another shaft is needed to pull the air back out of the structure.
- Natural stack ventilation: air pulled in from the facade and flows through the building because hot air rises. This is a low tech solution that has been used for ages in family houses. In my project a fan is needed on top of the staircase to ensure enough ventilation. In the floors that do not have riser floors an aggregate is needed.
- Mechanical, but in the floor: Under Floor Air Distribution. This requires less space and is more energy efficient than the common mechanical ventilation. Trox Technic.
- Displacement ventilation: used in cinemas and big open spaces. For example Oslo Airport Gardermoen and the Oslo Opera. Can be done very elegantly, but might not fit into my open and free plans.
- Windows can supply, but the ventilation can not be dependent on them.

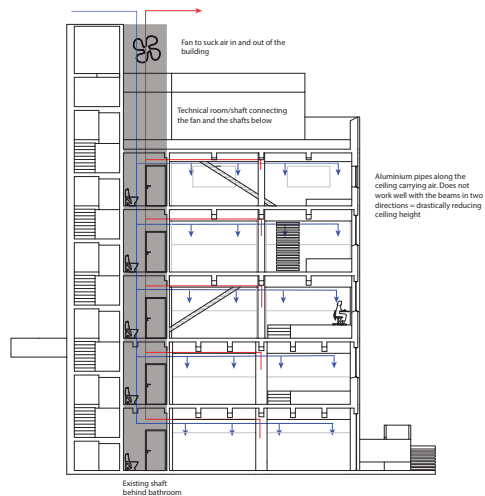

MECHANICAL VENTILATION

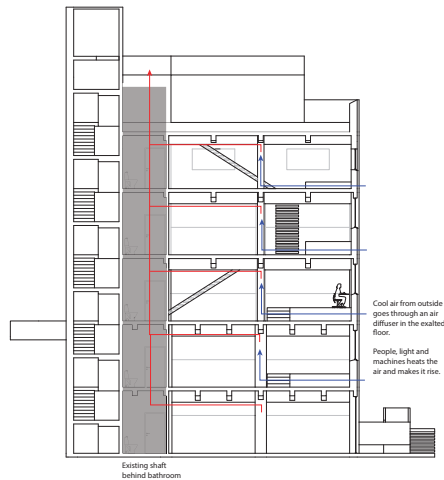

DISPLACEMENT VENTILATION

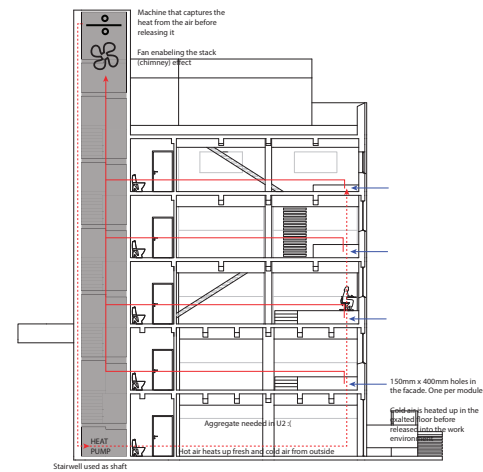

STACK VENTILATION

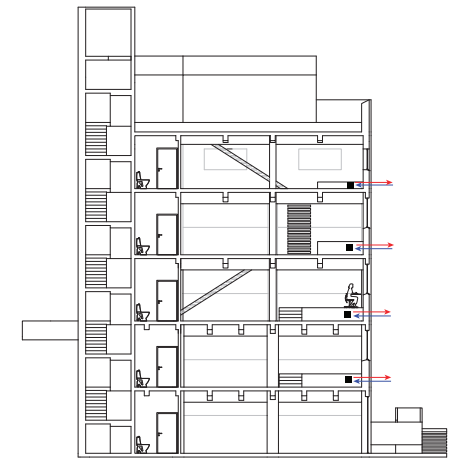

UFAD
Under Floor Air Distribution



This little black box is supposed to do everything

Glazed doors, variations.

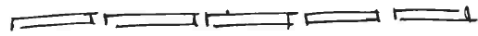

UTGANGSPUNKT

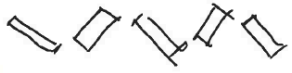

TREKKSPILL 5/5



FORSKJØVET 4/5



ANNEN HVÆR 4/5



SNURR 5/5

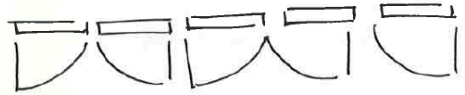

DØR

WEEK 47

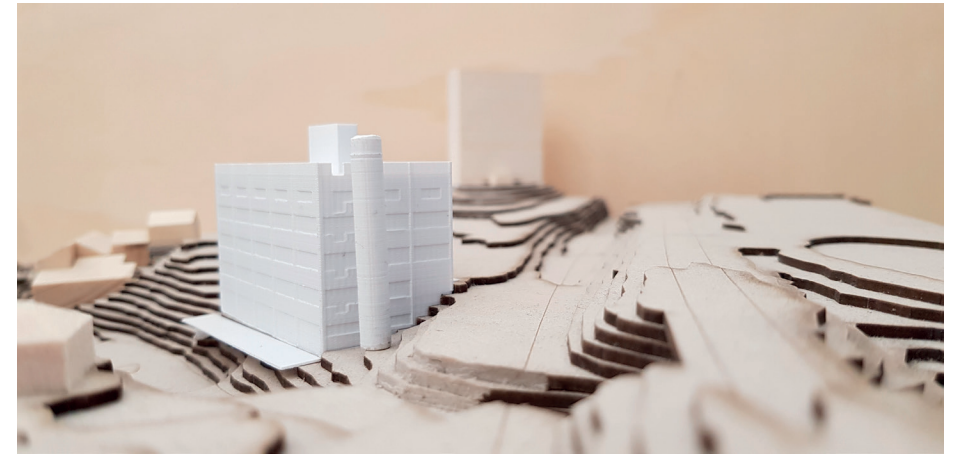

1:500 model of project at the current stage. 3D-printing lacks materiality, but offers possibilities of detailing in a small scale.



UNDEN I FA

WEEK 47

Supervision with landscape architect Vårin Huser 18.11.20

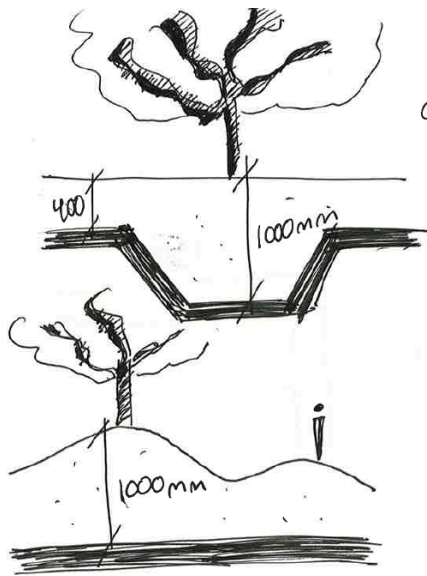

9 m³ m² treet hø til
retter

Terrang hvd man ikke
ken grave ned.

- sedum : 100 mm
- gress : 200 mm
- stender : 400 mm
- bark : 800 mm
- trær : 1000 mm

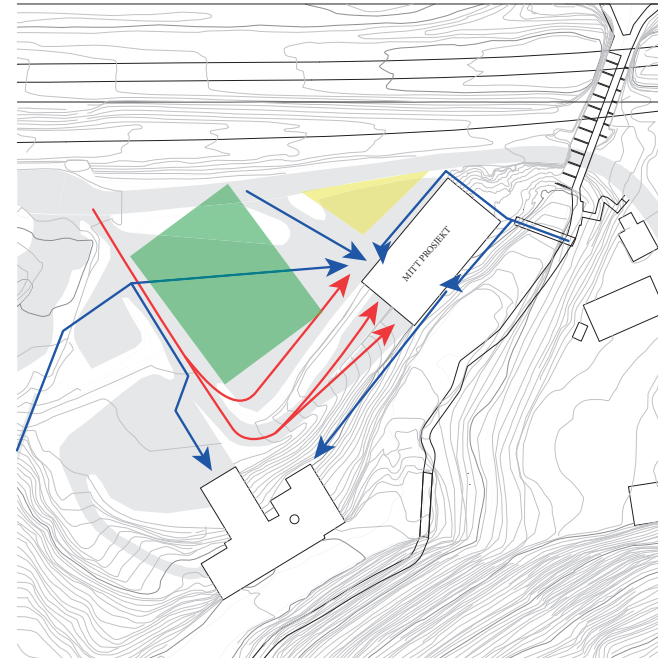

Arnjot Gellines vei 41 Revitalisering av Nygårdsfabrikken

Bygget er en gammel malingsfabrikk fra slutten av 40-tallet. Fra 77 har den blitt leid ut til ulike firmar, og fra 90-tallet til Bandidos og Hells Angels. De har overvåkande nok, ikke gjort stort for å holde bygget ved like, og det er ganske fallferdig.

Deler av tomta er i dag solgt og det skal bygges et stort boligprosjekt, Kværnehaugen. Dette er både dårlig arkitektur (planteinngangene) og landskapsarkitektur (situasjon) syns jeg, så jeg har bestemt meg for å heller foreslå noe annet på tomta. Det er i hvert fall dårlig for mitt prosjekt, som blir liggende ned i en dump på baksidelen. Utomhusplanen for dette prosjektet ligger på neste side.

Situasjonen ser heller ikke så bra ut nå for de har begynt å bygge. En stor parkeringsplass (både asfalt og grus) oppstår det meste av området.

Prosjektet mitt handler om produksjon, og i alle etasjene inne i bygningen skal det produseres noe (verksteder, arbeidsplasser, drivhus). Utomhusplanen burde ha noe av det samme programmet, for eksempel en scene eller basketball-iskøyebane eller leksplass eller et torg for matmarked, løppemarked osv. Eller noe annet, det meste kan man vel argumentere for at legger til rette for noe slags produksjon.

De røde strekene er nødvendig biltrafikk: de tre nederste etasjen er verksteder og de trenger varelevering. I tillegg må jeg vel ha en parkeringsplass hvis noen trenger å komme med bil (HC).

De blå strekene er hvor man vil komme som gående eller sykklende.

Det grønne feltet har kanskje mest potensial til å bli et stort utendørs program, mens den gule trekanten vet jeg ikke helt hva kan bli. Den gule delen er i dag avgrenset med høye gjerdet fordi Bandidos fortsatt leier i første etasje av bygget. Jeg har ikke fått komme inn og se engang.

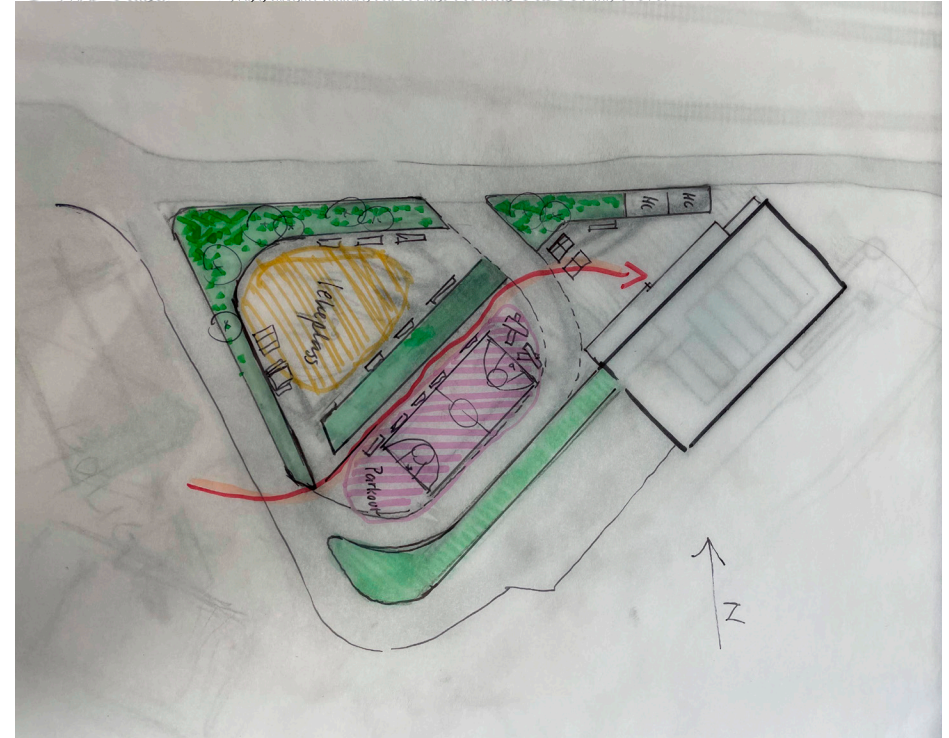

WEEK 47

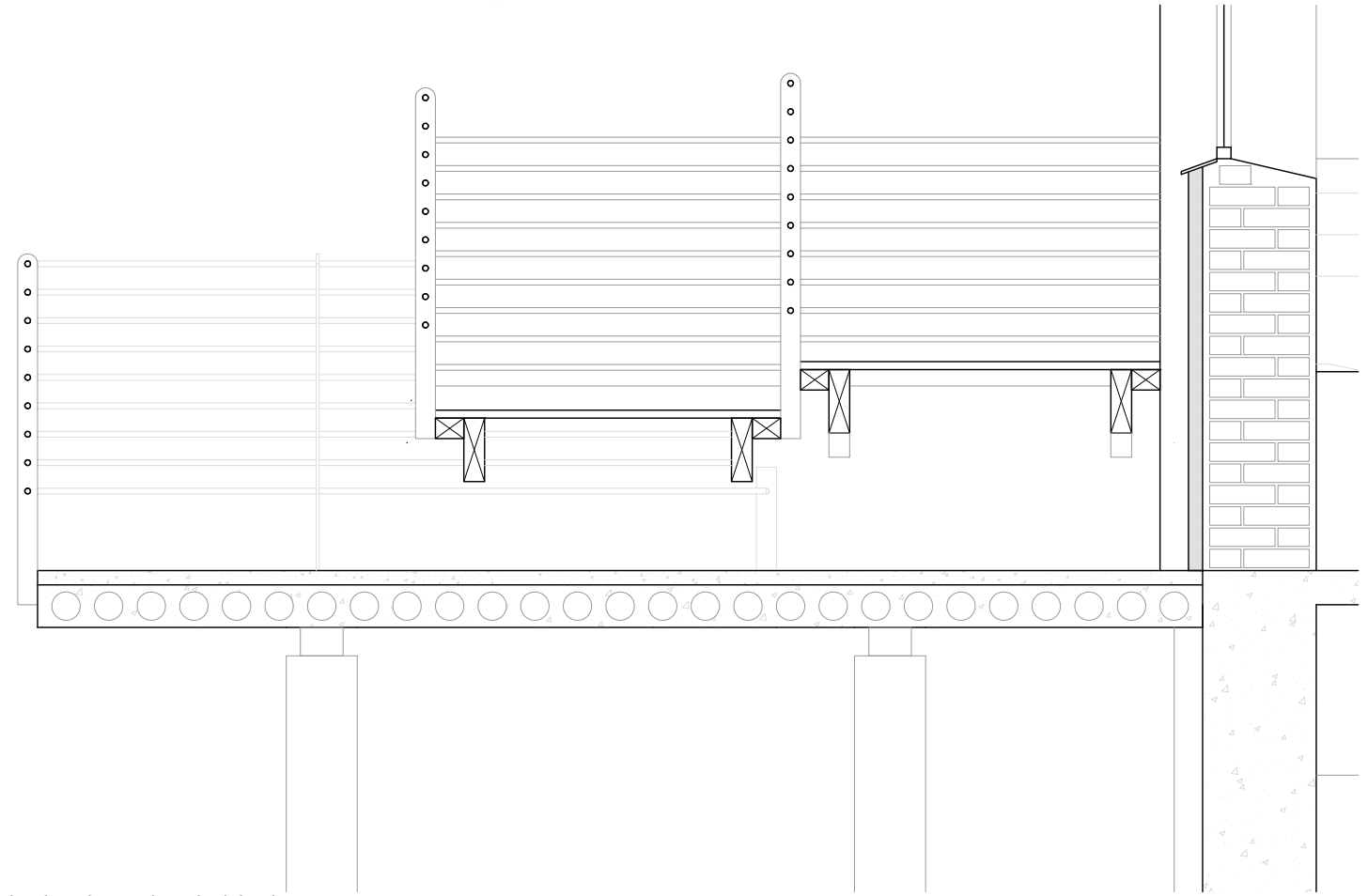
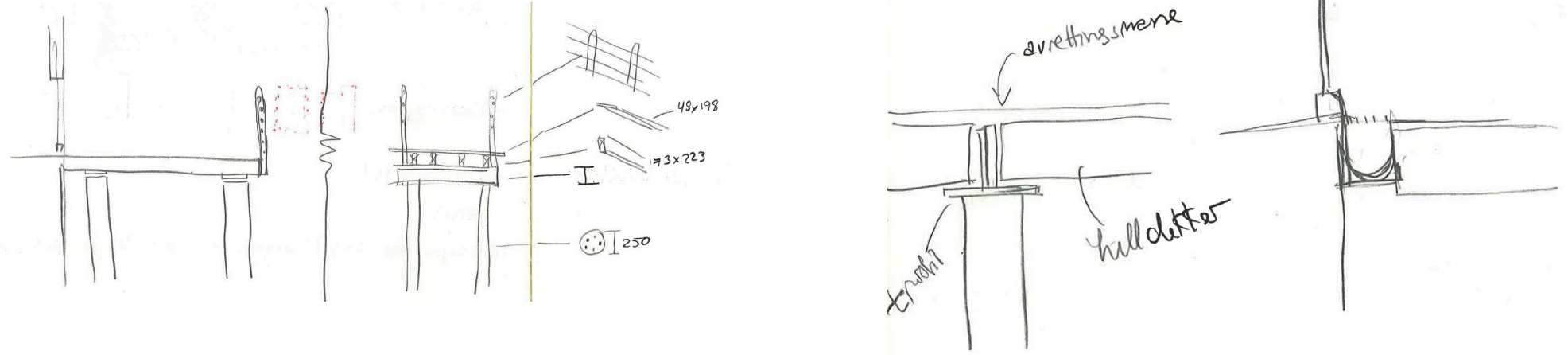

Terrace U2 construction. Learning from hiking trail D10 across the river: low-tech and minimal impact on the local environment.

Teknisk hefte

- Ventilasjon

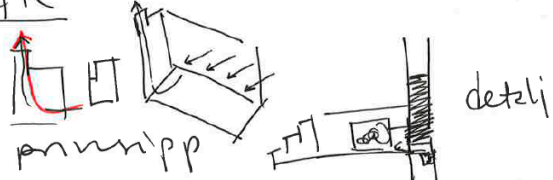

- isolasjon

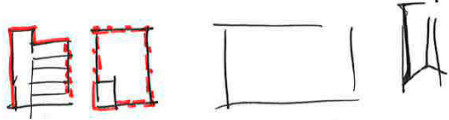

- elektrisitet

- vann

Kanslye peg ikke skal ha opplevestapp? Skaper ikke så bra arbeidsro. I grunn.

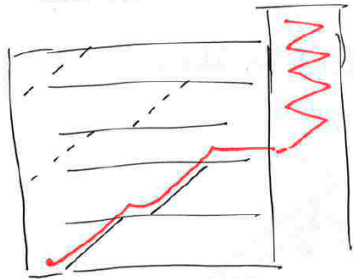

Eller sjikt i samme sone.
Egen sone

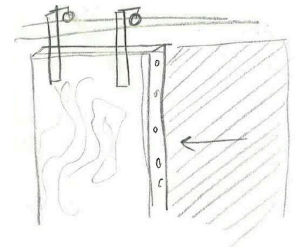
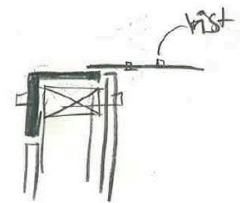
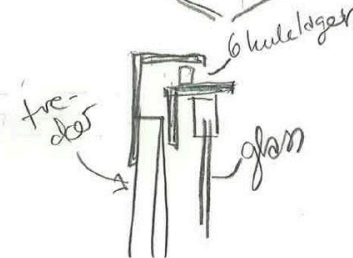
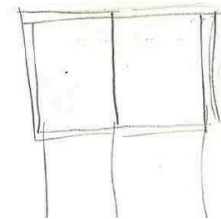
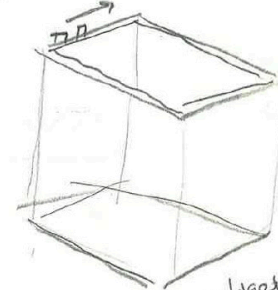
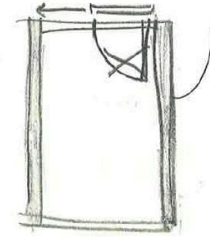
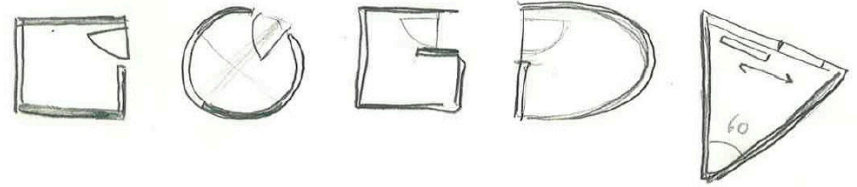
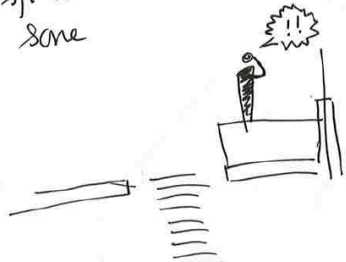

The individual production space (offices) needs some closed rooms for private meetings and phone calls. As I want to keep the open space, these private units should be mobile and deconstructable.

WEEK 48

Supervision with architects Espen Pedersen and Axel Fiske, Lund+Slaatto Arkitekter

- The project is about the small and correct interventions that makes a big difference
- Sobriety and low-tech. Possible to transform again.
- Add simple diagrams that explain the why-part clearly
- Keep the extremely effective structure and organization: corner or mobile

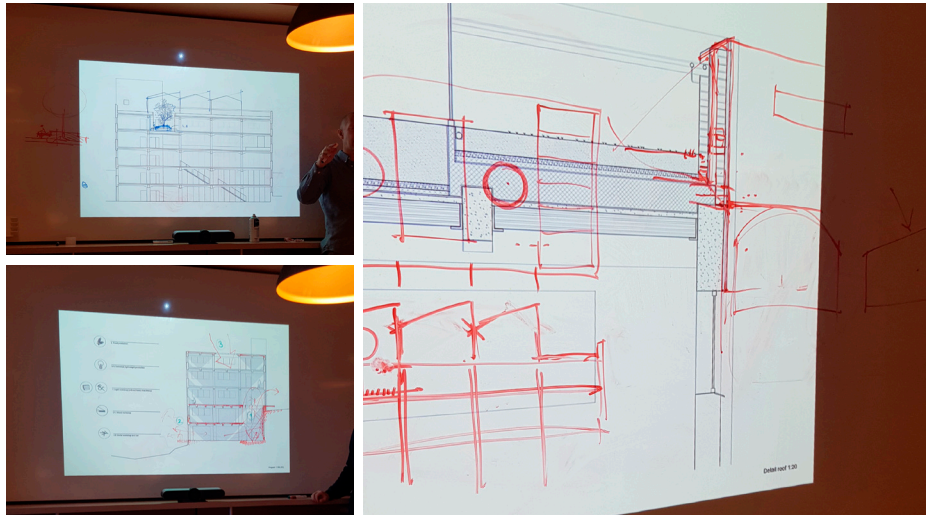

Designing the office space more efficiently.

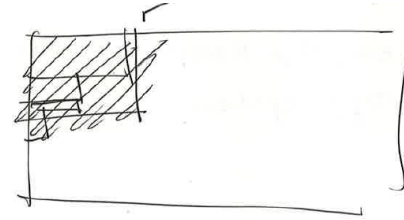
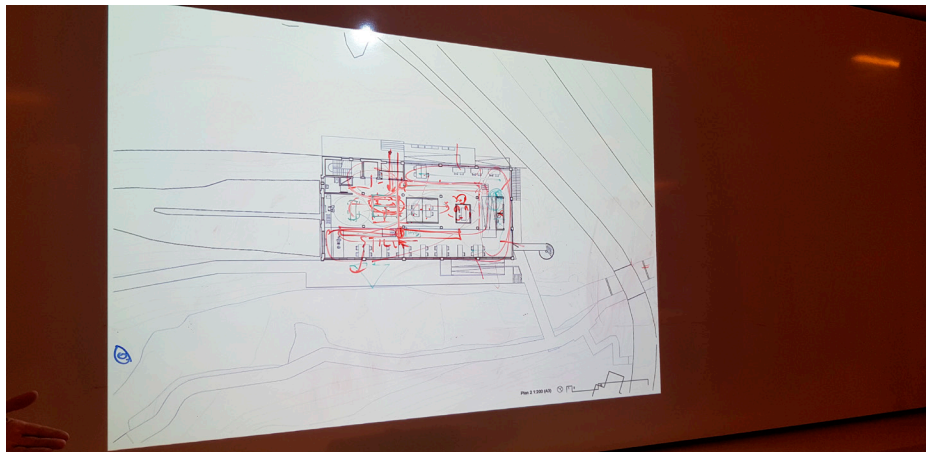

Include diagram of keeping all necessary functions in one corner. Efficiency plan.

- ① Åpne gulv
- ② Connection
- ③ Åpne tek

Include diagram with the steps I've taken and why.

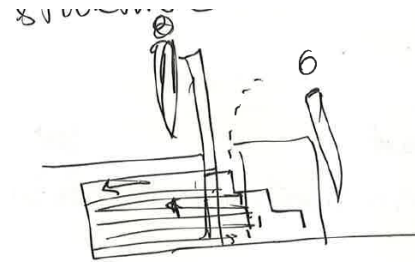

Wall or fence between mezzanine along facade and space in the middle. Back wall for heavy machinery and place to hang tools. Space under for storage and all tech. infrastructure.



Roof parapet with lighting that does not blend the people.



Different ways to shape the greenhouses on roof. What is more functionalist (both in the original sense and in the style sense) vs. what is more site adapted.

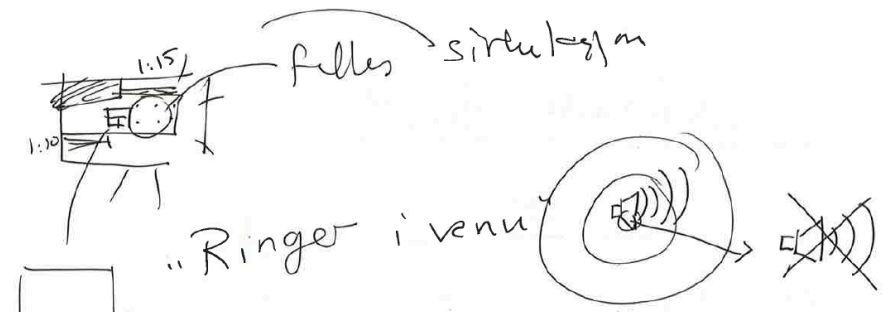

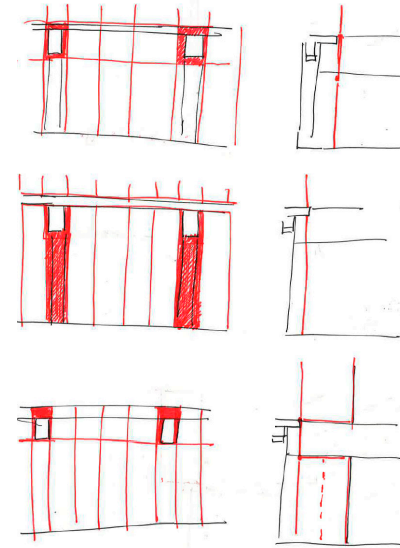

Different ways to organize the continuous glass making up the light room. Beams should not penetrate the glass, this will only result in much sealant.

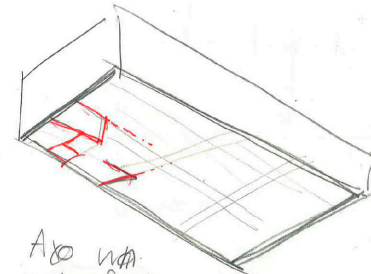

Axo nedre
 neden fra for & use at byllene i etur
 grad styrer hvor jeg planer vegger.

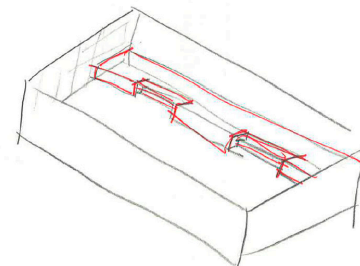

Axo overfra
 for & use
 hvor jeg
 planer
 opp fra
 gulv.

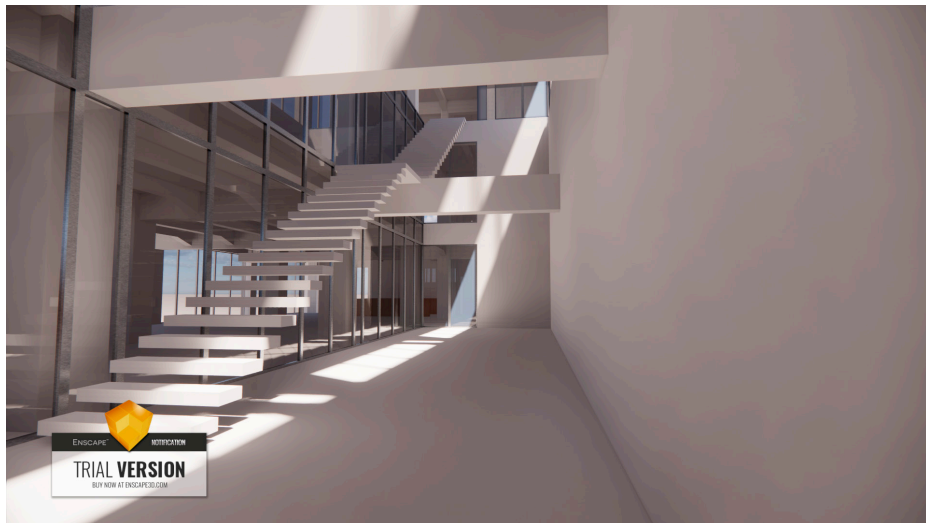

Sketches on how to explain the interventions. Axo from below shows how the storey-tall walls integrate with the beam structure. Axo from above show the raised floors creates different zones.

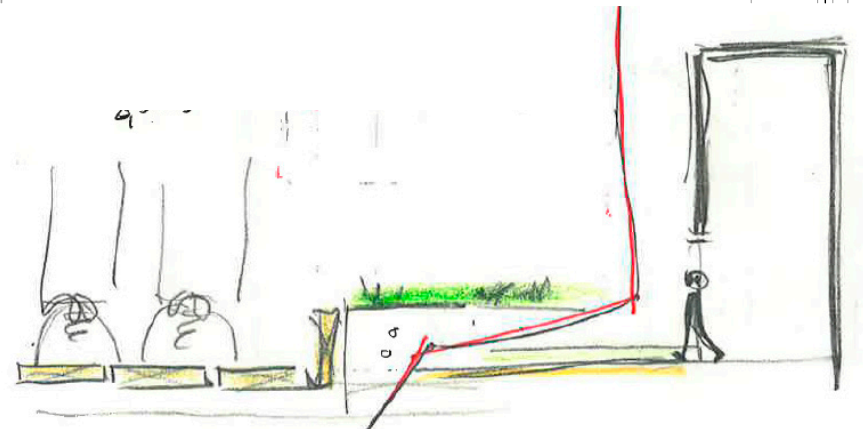
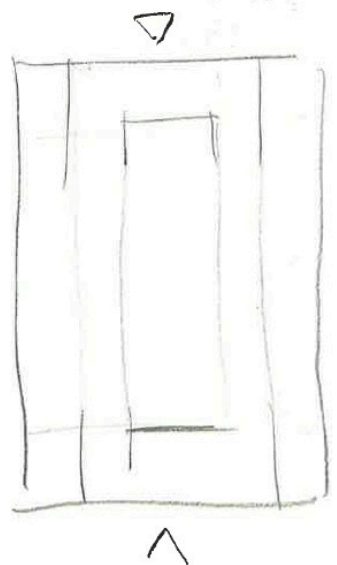
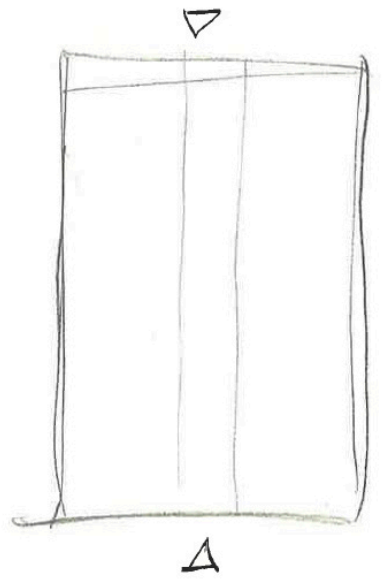
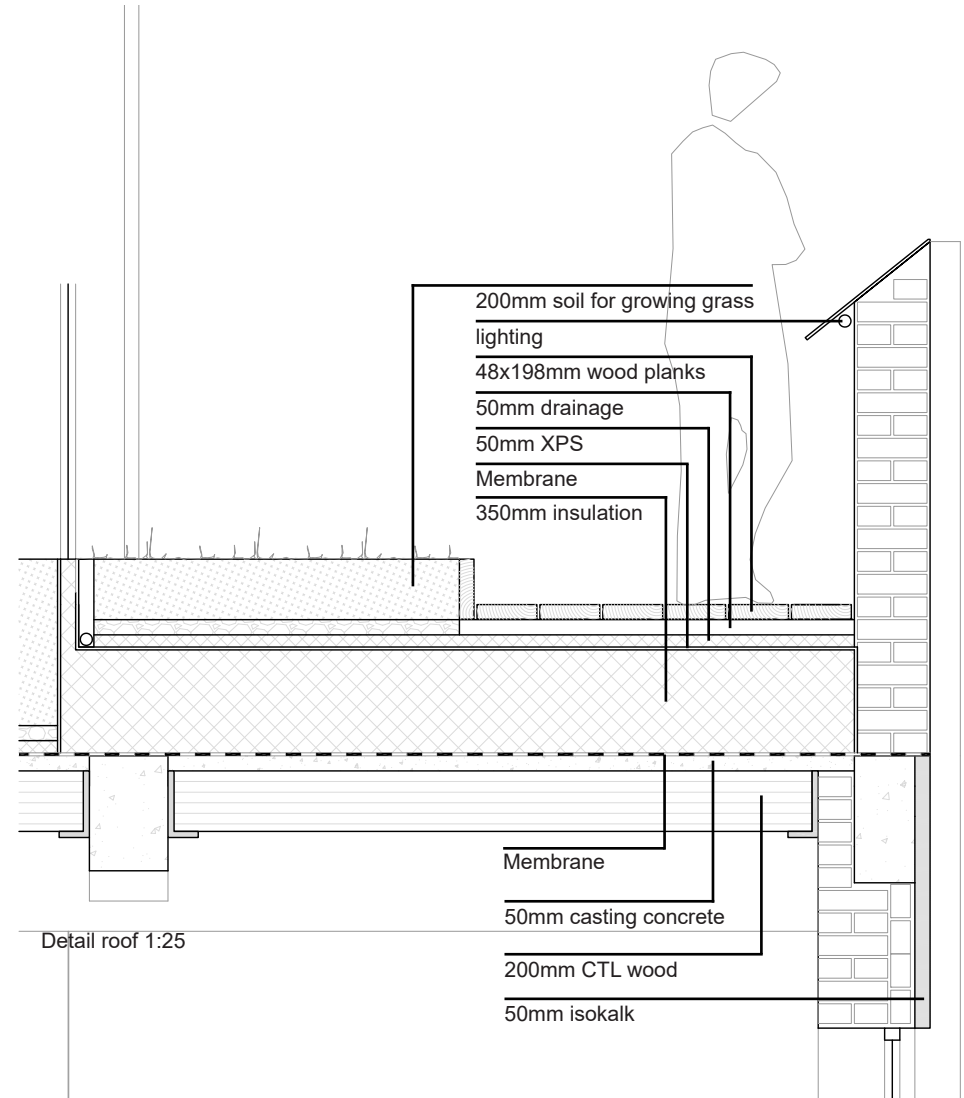
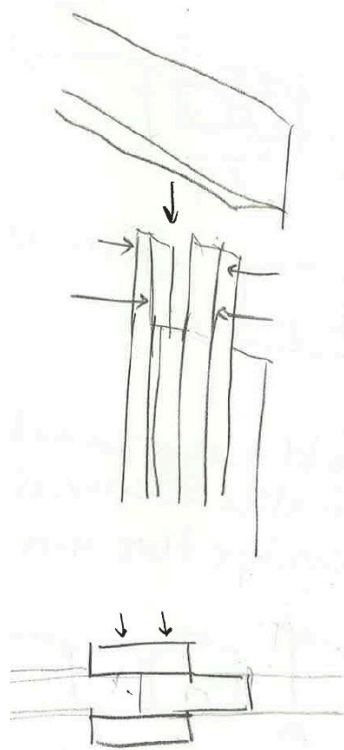



U2: Lowest floor. Illustration shows light room and materials. End grain wood is used on the rised floors. This material is very durable, and has a history of use in heavy industry factories.

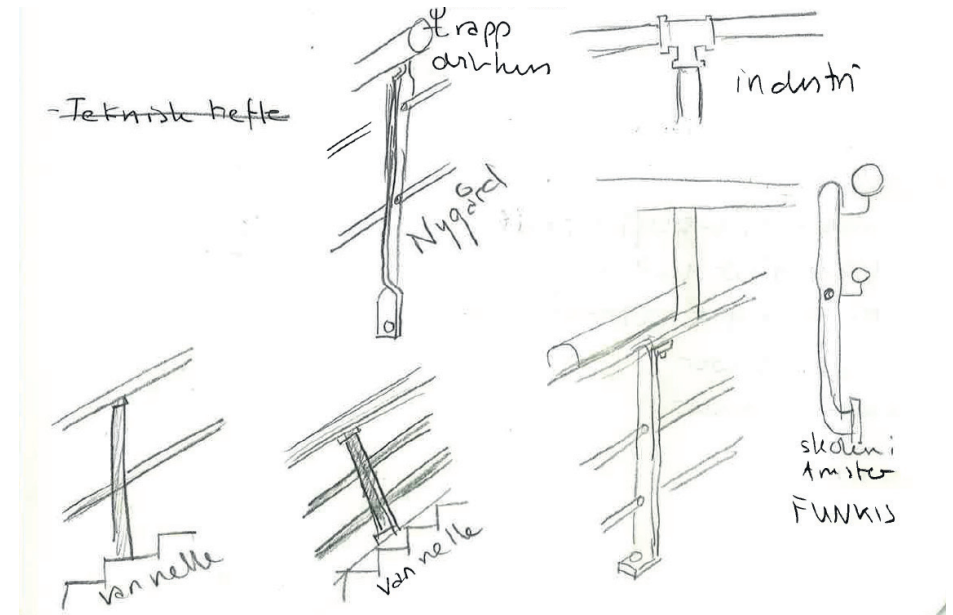

Different railings. Industry vs. functionalist. Difference and similarities.



Loft: Highest floor. Illustration shows the new CLT ceiling and how it is hung between the original beams. Two holes are cut out in the original ceiling to enable light to enter the otherwise dark space.

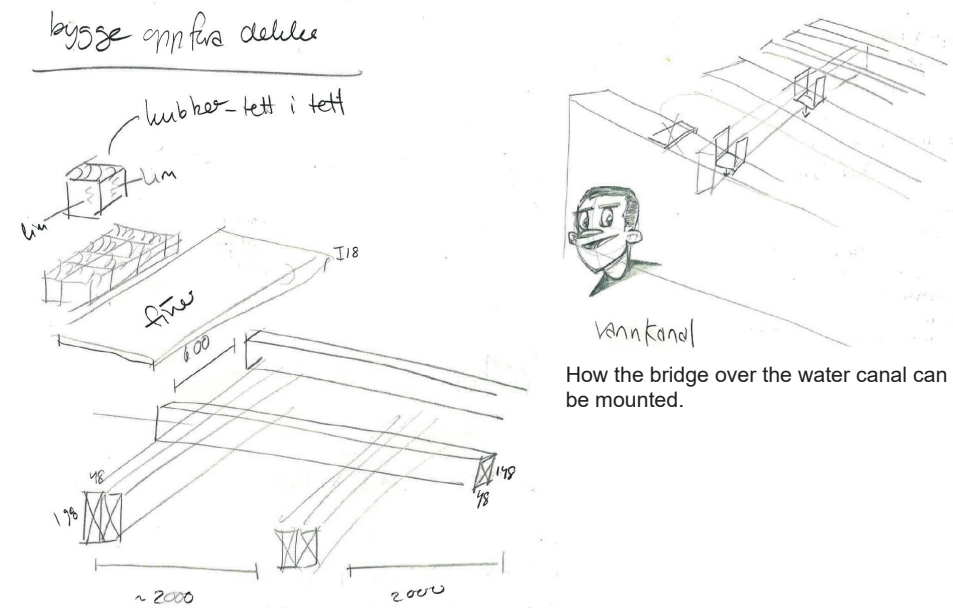

How the bridge over the water canal can be mounted.

How the rised floors can be built up.

1 SUBTRACT

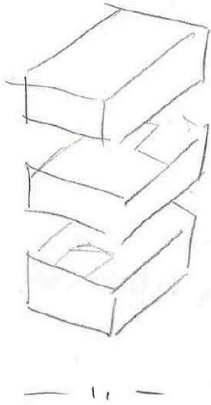

3 ADD/MOVE

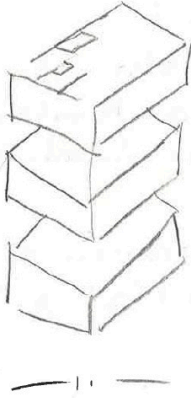

2 ADD

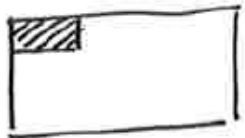
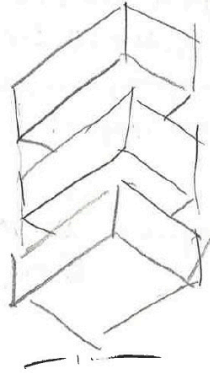

Diagram plan organization

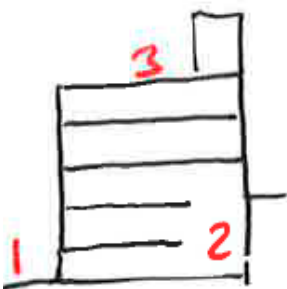
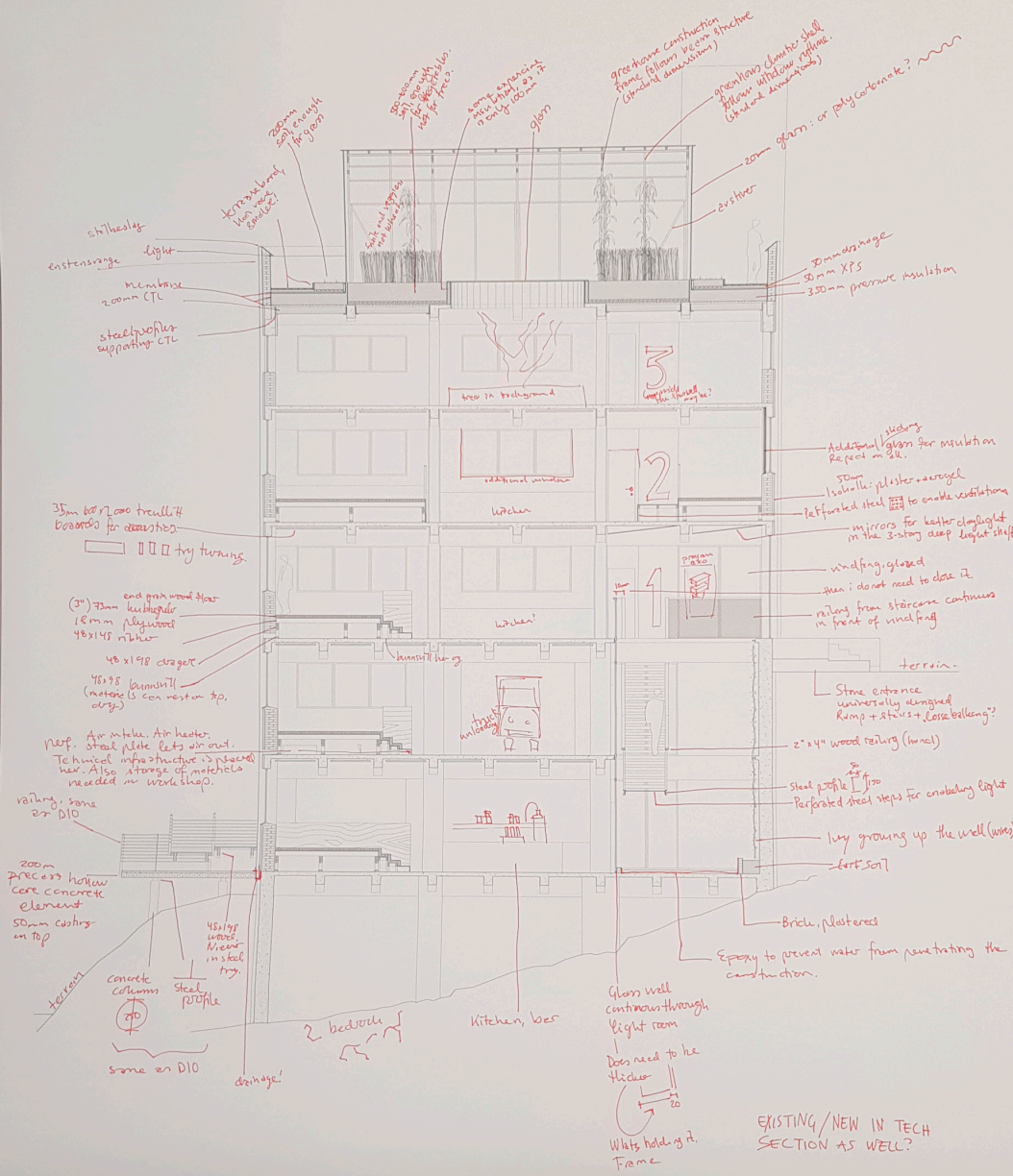
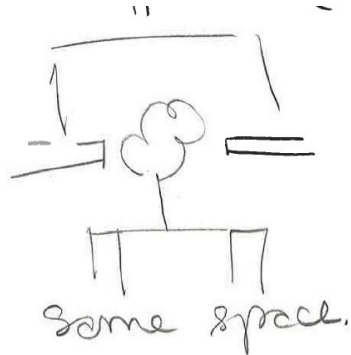

Diagram section interventions



EXISTING/NEW IN TECH SECTION AS WELL?

1:50

Texting technical section on 1:50 print. The section show low-tech building method throughout the factory. Under the rised floors there's room for technical infrastructure and storage. The greenhouse on the roof follows the same construction system and window rythm.

WEEK 49

The building used to be a paint factory, owned by Nordiske Destillasjonsværker until 1977. How can I use paint in this project? Both to remedy its original function and to make the space more authentic.

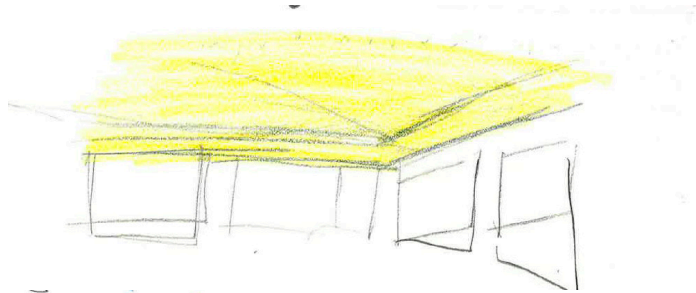

Ceiling

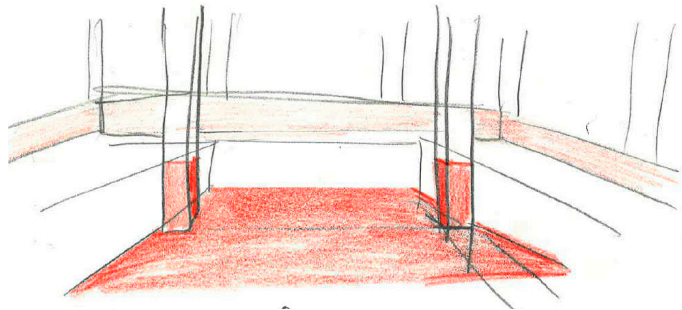

Floor

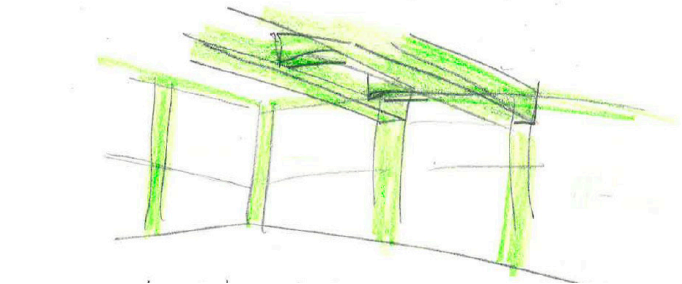

Structure

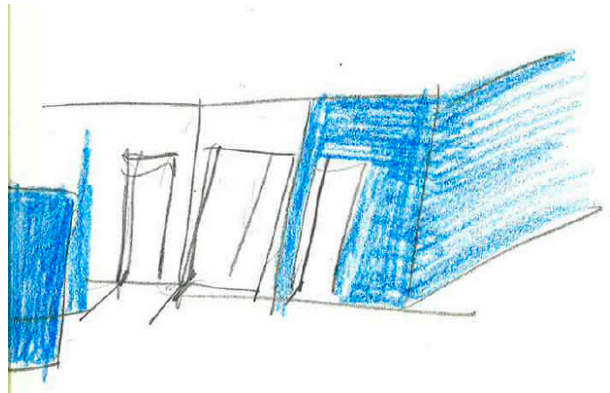

Added walls

Other:
Color follows function



Red/brown paint in the loft. This looks like it filled both these walls at some point.

50 shades of gray. Apart from the stairwell, most of the interior is painted white. I have not found any interior photos from the early days. When removing some boards that were placed along one wall of the core, I found evidence of some previous painting. Most of the layers are some shade of white or gray. In the corner of the previous door (?) there is some blue colored paint. May be this filled the entire floor, or may be it marked the core.

WEEK 50

Paint studies. Should I really do this, less than one week before delivery?

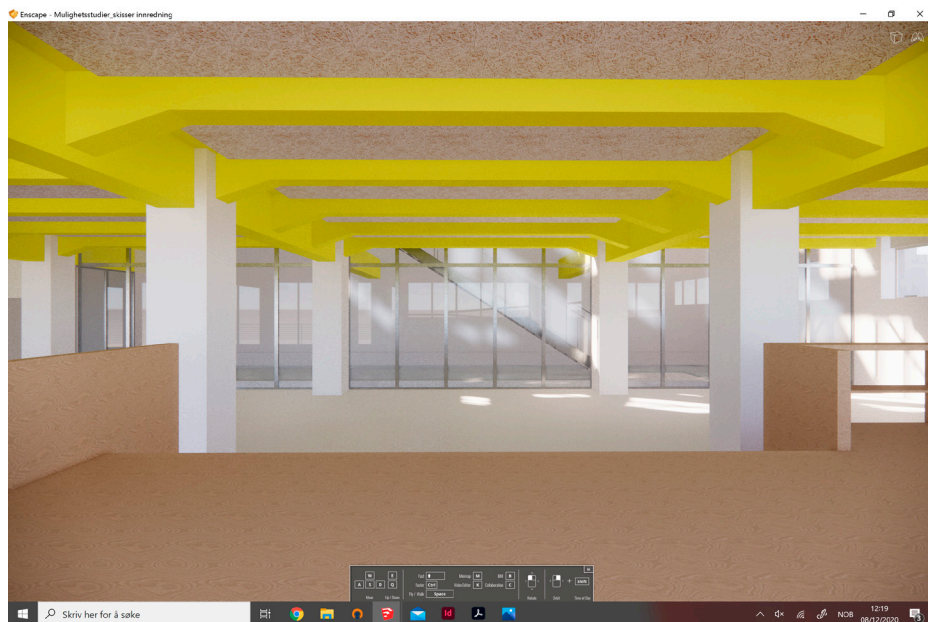
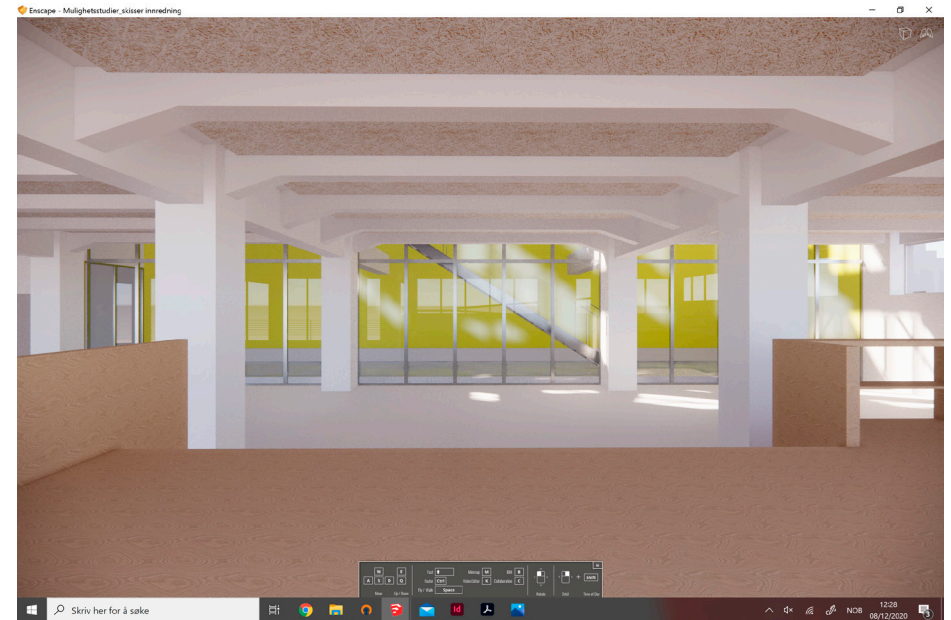
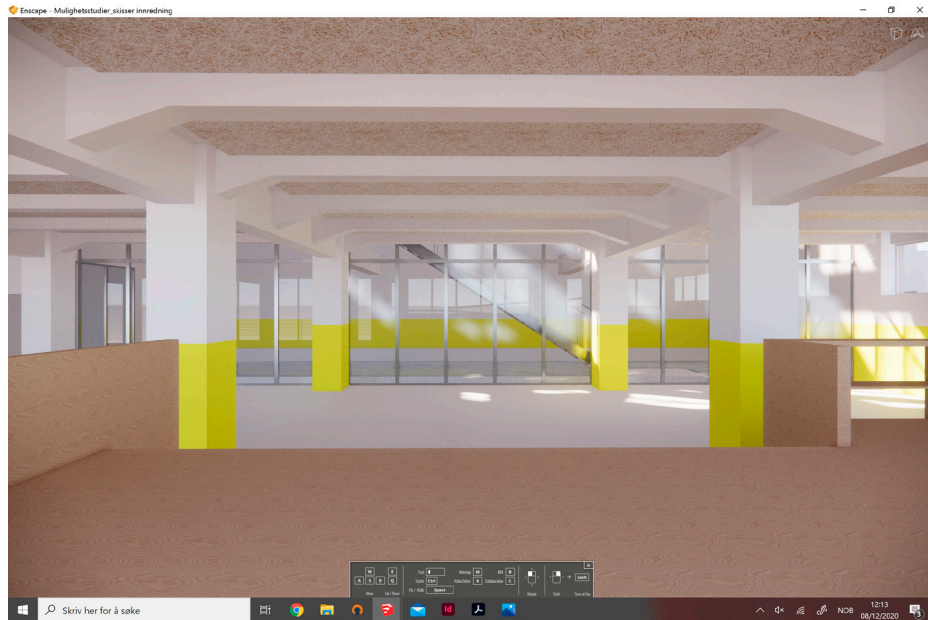

WEEK 50

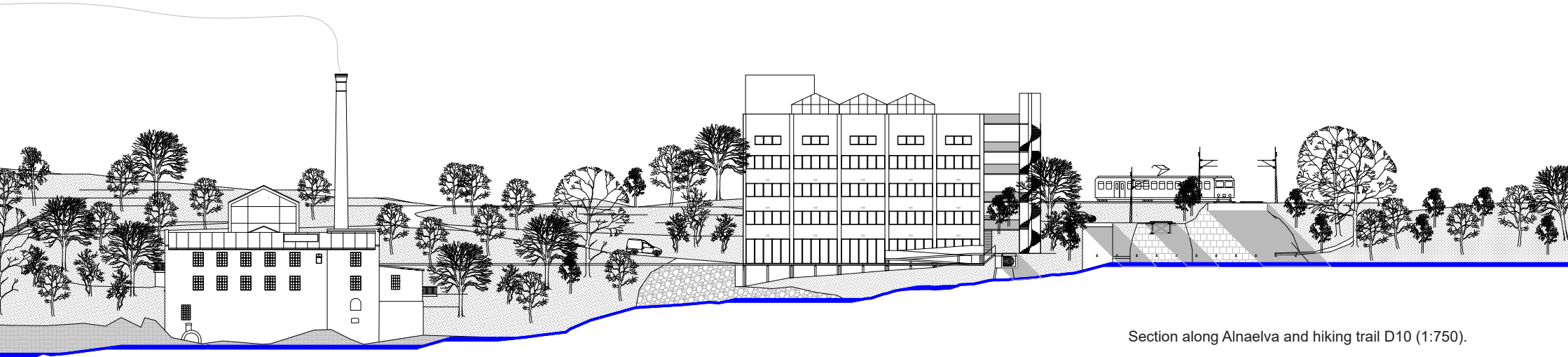

Section along Alnaelva and hiking trail D10 (1:750).

PRODUCE PRODUCE PRODUCE!