

Haharchitecture - background, foreground and photos

Preliminary work - spring 2020 to present day

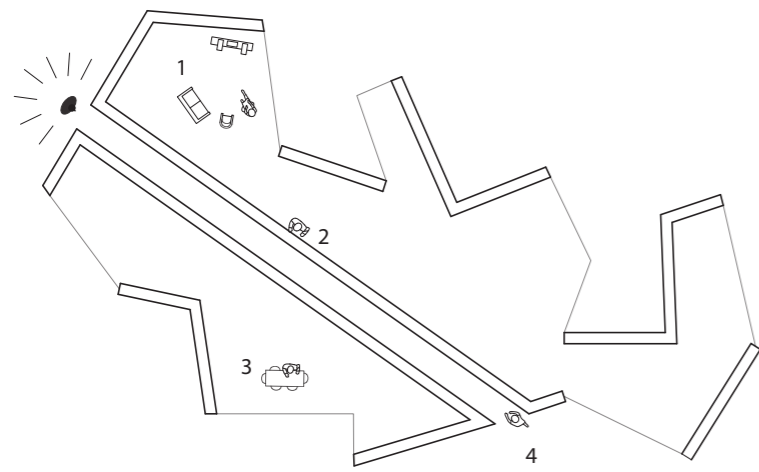

1. Maybe some people could sit here, listening to ska.
2. Meeting the wall, just about here.
3. Breakfast or brunch in here, I think
4. Imagine seeing the Nun at the other end!

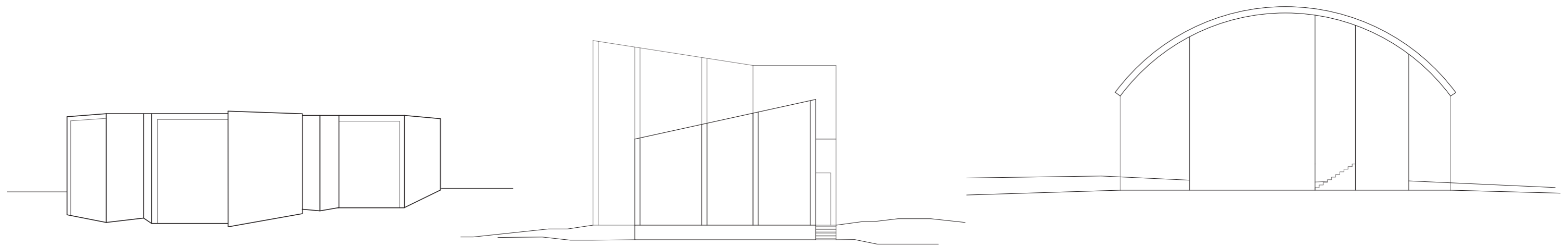
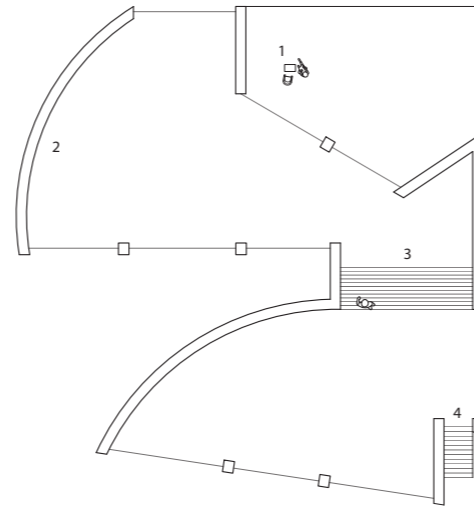

1. Who would have a cigarette break here?
2. Someone did a graffiti of a fly here
3. Some steps
4. Escape

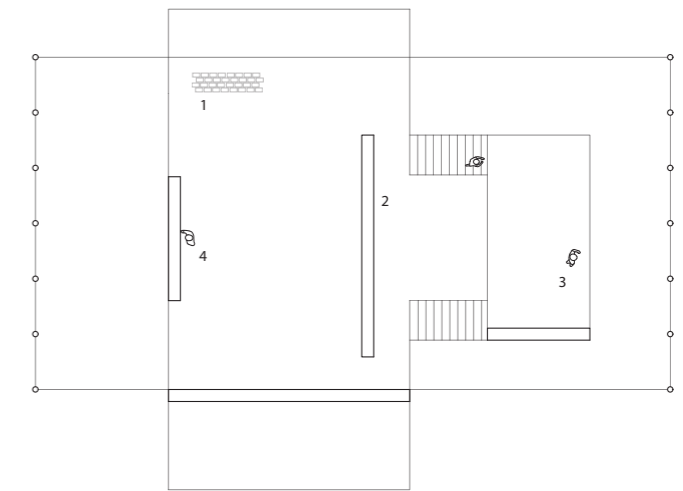

1. These remind me of my grandmother's tiles
2. Clever to have a wall here for shy people in stairs
3. Stop here to enjoy the view
4. This bookcase is really too big, who can reach the top shelf?

Compositions about the human factor in seemingly incomprehensible architecture

The information given in a plan drawing can often be difficult to absorb

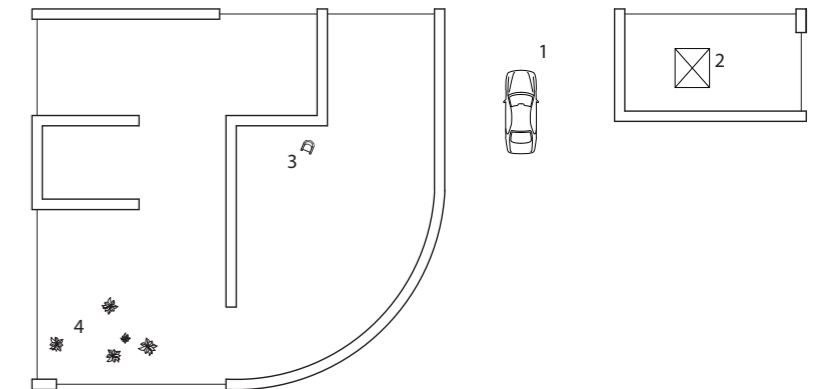
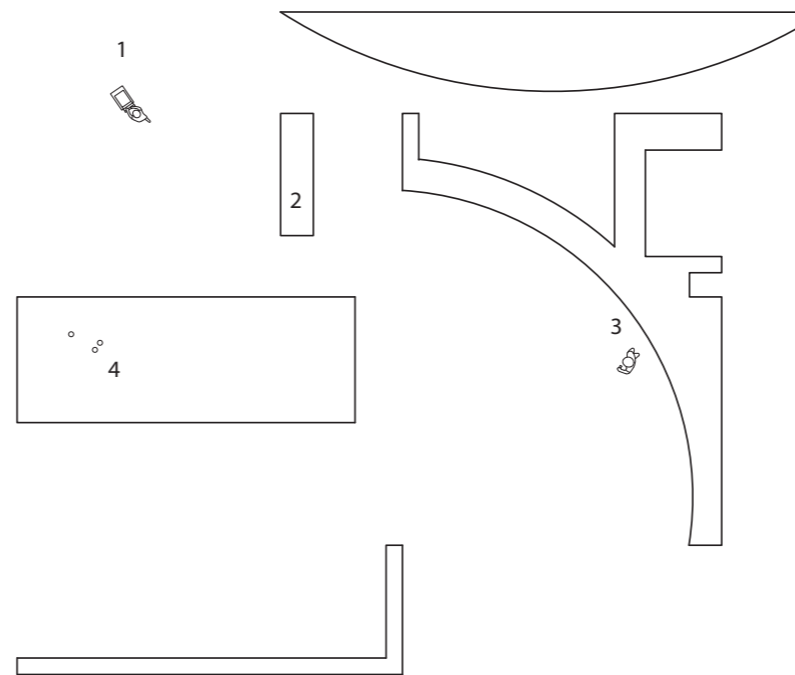
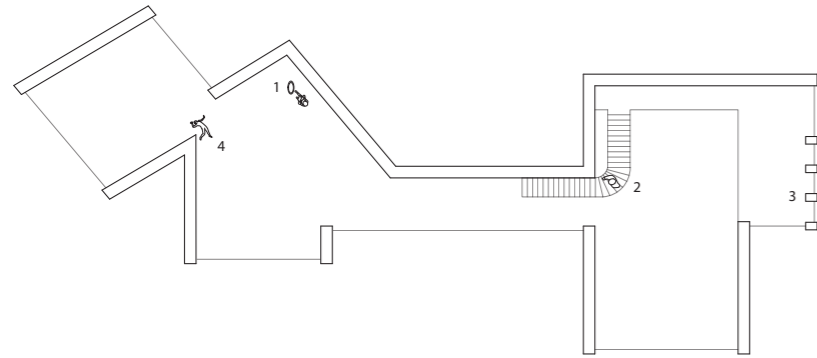
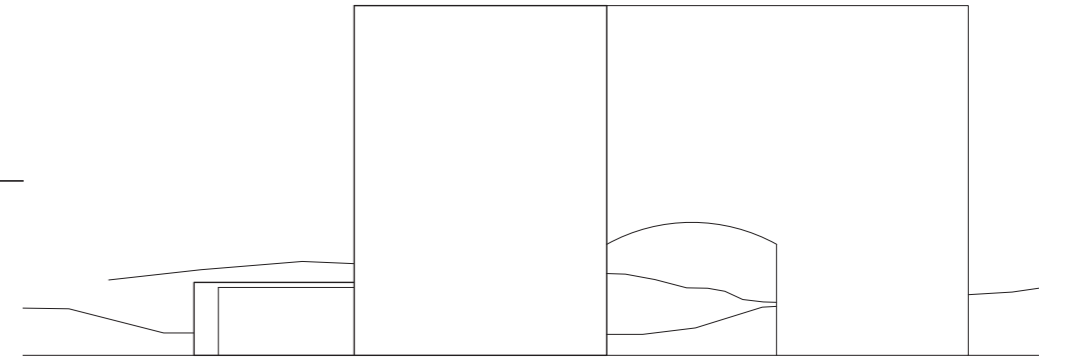
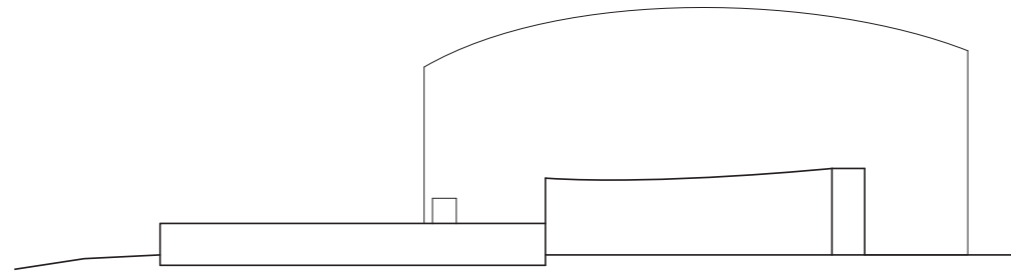
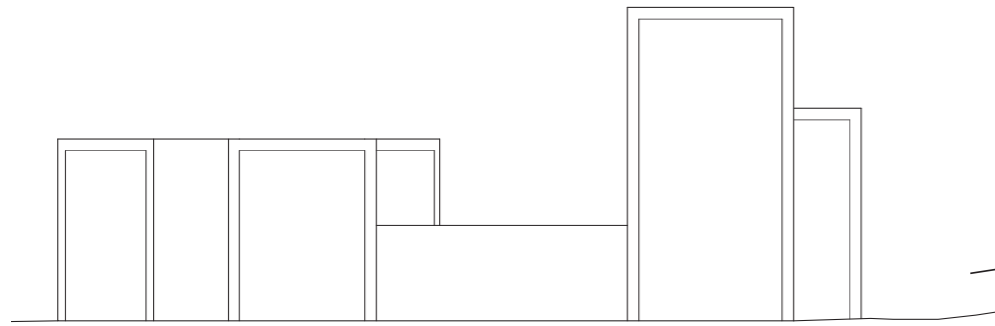

1. This could be nice as a nursery
2. Turn here, I think
3. I've never really thought about those..
4. Someone could really hurt themselves on that sharp corner

1. Haha, who's going to mow that lawn? Not me!
2. Large outdoor fridge
3. Curvy walls for curvy calls
4. I would turn this into a swimming pool, instead of a bocchia-field

1. You drive in here?
2. The elevator comes down here?
3. What happens here?
4. With all this space, shouldn't there be more plants around?

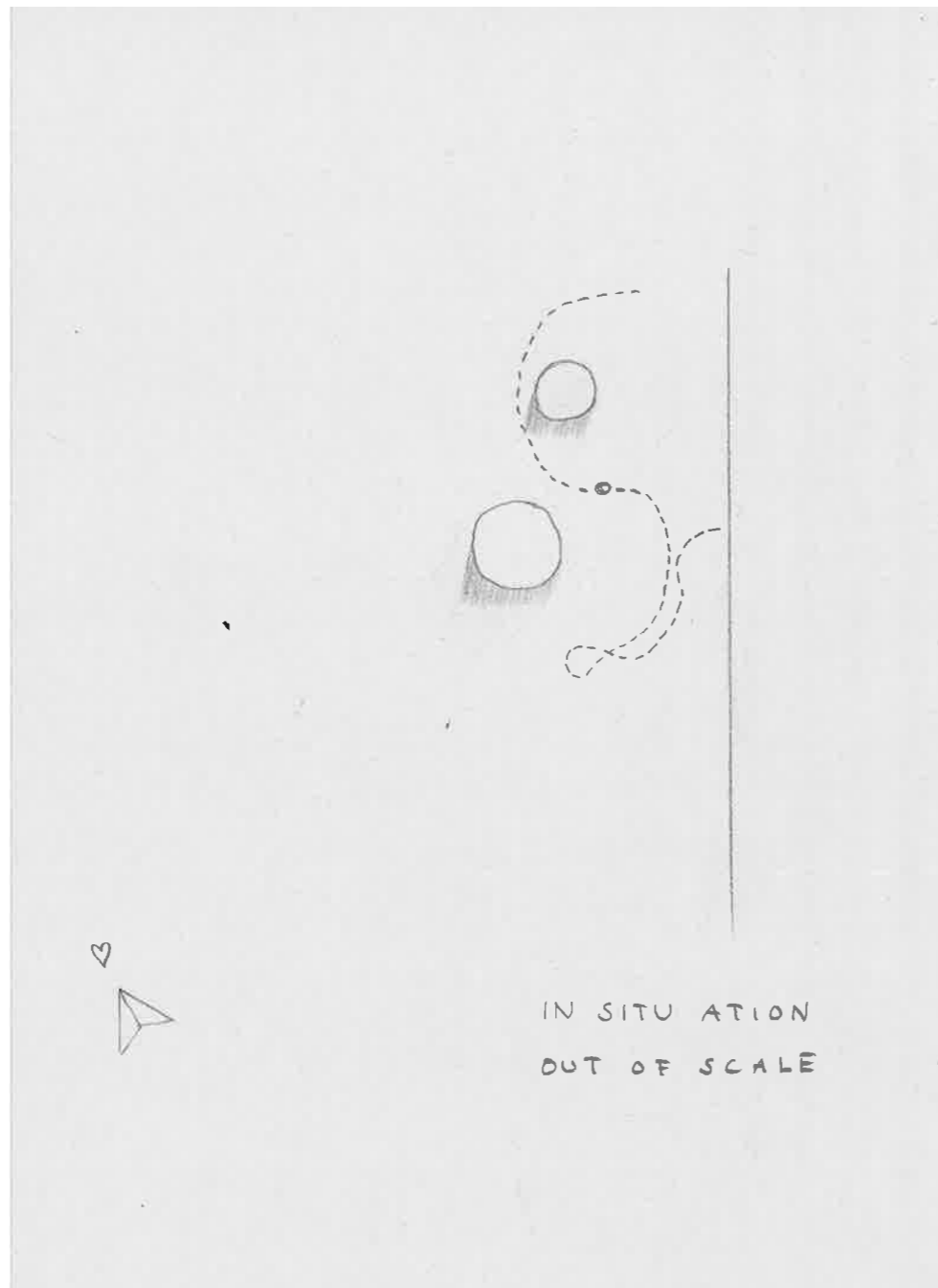

Drunken Betsy

Drunken Betsy wobbled out from the pub, the early morning sunlight harsh in her eyes. There was no shame in spending some quality time feeling sorry for yourself, after the trauma of getting reelected as Head Mistress of the Sheets in His Majesty's service. No shame at all. It was all she could do, in fact, the only thing still in her power to do, in the short time before they discovered hiding place and rounded her up again. She figured she had about three more hours. And she would spend them with her favourite boy-toy, Big-Ben Albus. If only she could remember which way to go. As she tried to focus on getting her legs not to drag so much, the wind caught her petticoat and threw her completely off balance. Landing awkwardly on her side, she heard an unmistakable snigger from an alley-opening to her right.

"Heartless bastard", she mumbled as she scrambled to her knees and dusted off her dress as best she could.

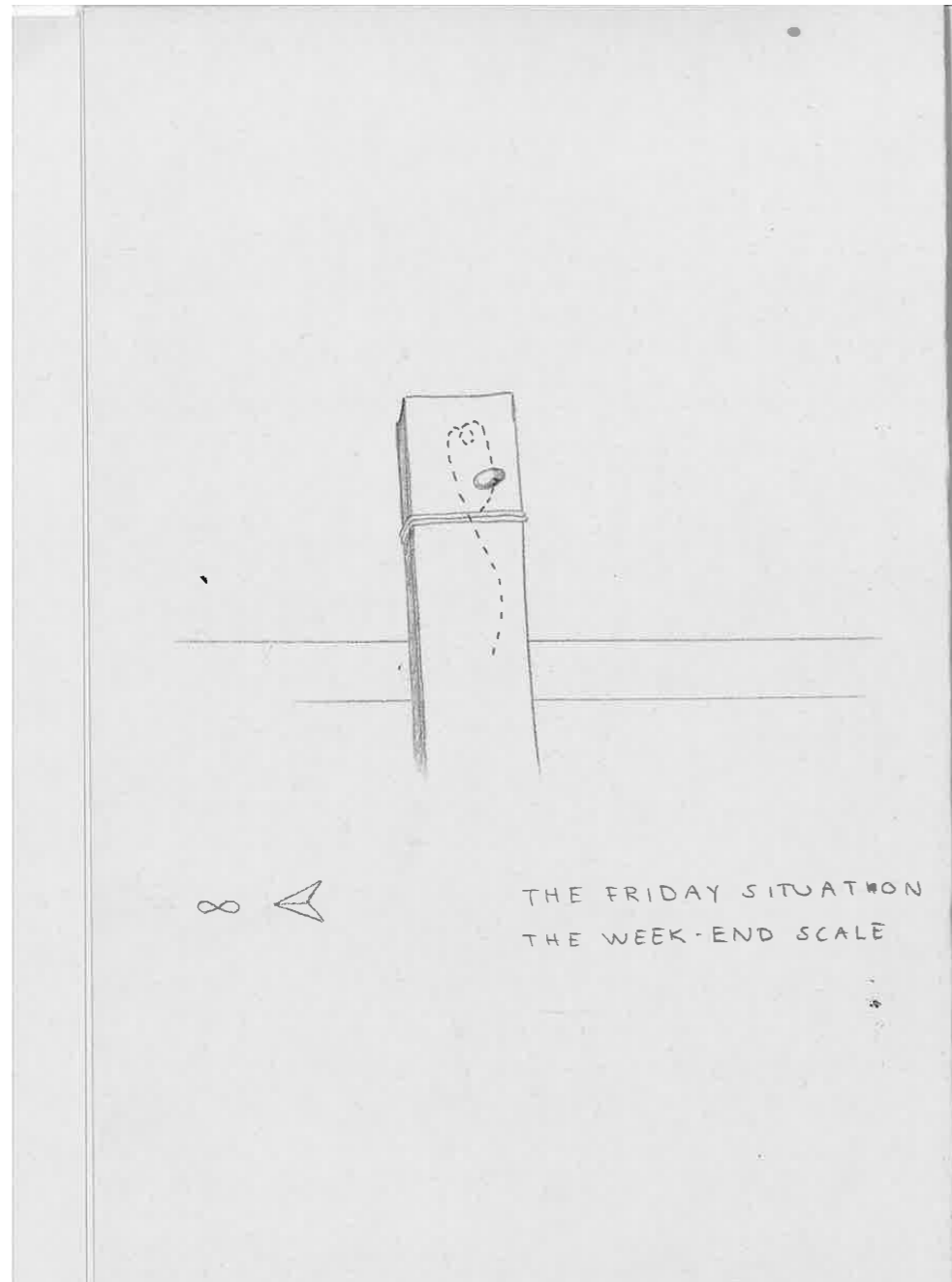

Face Changer

The stupid man had made another stupid mistake. Millions were lost, a town completely razed to the ground and thousands had died. But this wasn't what bothered the stupid man, not entirely anyway. The fact was that moments before the mistake was made, he had hesitated. He had suddenly felt a new sensation of disquiet. One of the many things people called the stupid man was head-strong, stubborn, single-minded - and take it as you will, but he was NEVER insecure or unsure of anything.

Hesitation was a waste of time, he felt. You just act, go for the gut instinct. Ask forgiveness later if you have to. And yet. This time he had experienced hesitation, although not enough to tip the scales. He had still gone through with it and made all those stupid things happen, to a catastrophic end. What would have happened if he had stayed his hand, and listened to that hesitation?

Did he even know what the alternative to action would be?

The stupid man kept playing the moment over and over in his head, trying to remember what had triggered it. It was one of many mistakes he had in the last few years, and he had gotten used to the remarks and bullying from his colleagues. But he had to admit, a mistake such as this was a first. It would be a hard journey indeed, to gain some trust and respect again, but eventually it would be business as usual. The stupid man would continue doing wrong and stupid things, on a smaller scale obviously. He lifted his eyes from the pieces lying scattered on the board and made a funny face. He would never learn and thank the gods for that, his friends thought.

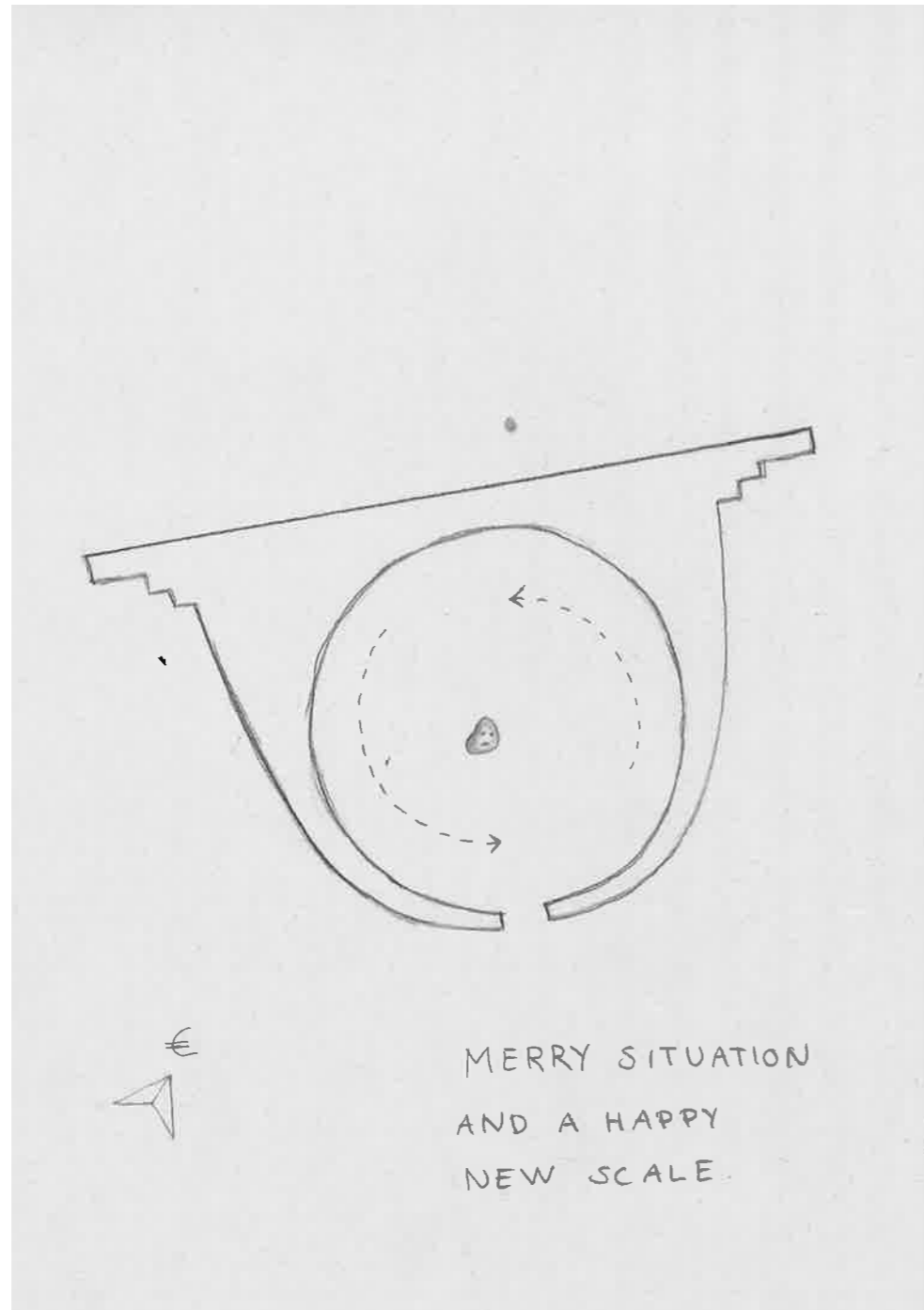

Spinning House

Powers at play that only works at certain times each night, when desperation for the unnatural really has its hold on you.

In the early days, when mankind was starting to get the hang on things, Gods where born by the ritual of architectural dancing. Celebration of the comfortable shelter where you could put all your favourite things.

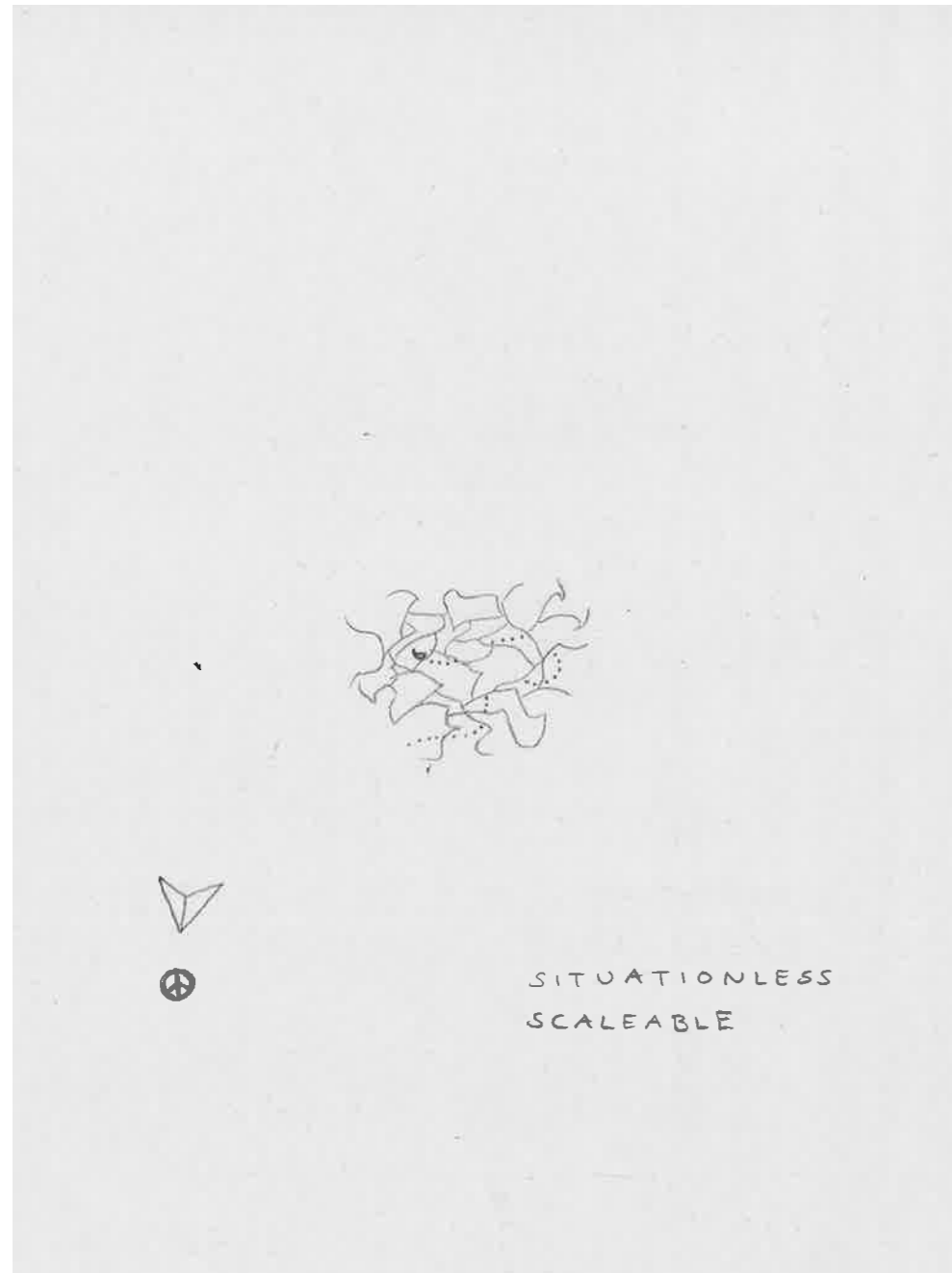

Cloth

The sea and me, we had a sacred pact long ago. I come down to the shore at certain times every year, throw myself into the waves and drown. I get dragged out by the strong currents and when I get far enough out, I sink to the bottom.

The pressure is enormous, yet there is a calmness in this dark world that takes all my fears away. Lying like this, my clothes shifting slightly with the hint of current, I open my eyes and see my friends waiting. Their shapes have adjusted to the water to use my fins and tale to move. The sea expects a certain style from its denizens. A transformation much like the different stages in life, where one also needs help.

So now, having left my humanly body on the sea-floor, I join my friends and swim fast away, down to the deeper darkness of the sea. When it becomes impossible to see anything and the pressure of the imenseness is crushing and become literally unbearable, then the sea reveals itself to me.

I give the sea my thoughts on the week just past - what wason the news, what discoveries were made, what my daughter said one evening that made me and my wife cry, what the weather was like and how often I went to the "dentist" instead of doing routine checks in the department catalogues. The true sea knows all about the "dentist".

When I am done and can think of nothing more to add, the true sea nods, contemplating maybe, and sends me back to my friends with the usual "SO LONG AND THANKS FOR ALL THE FISH".

At this point I always black out, and wake up again feeling refreshed and inspired next to your grave.

Sea you next time!

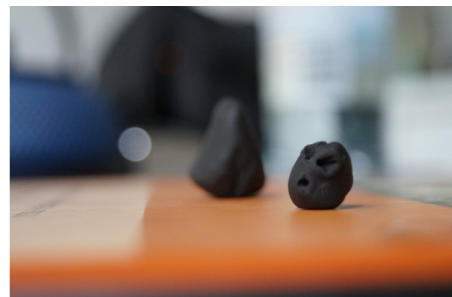
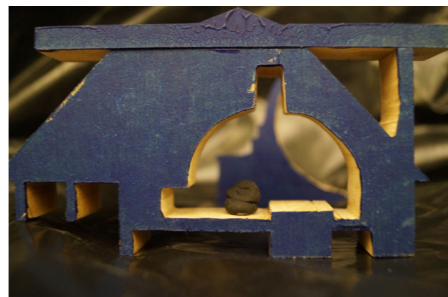
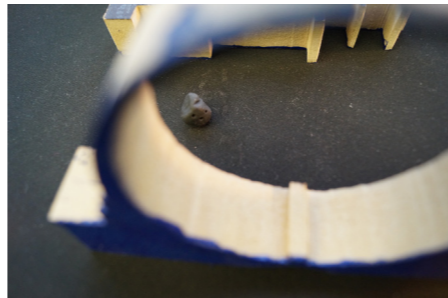
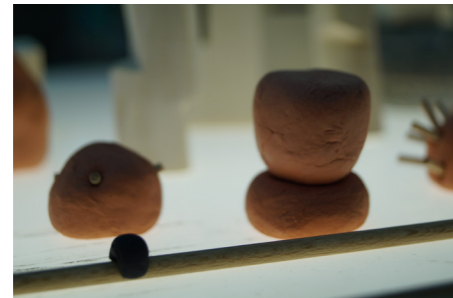

Stills from the animation films

LOOK

This is what goes through the teen-age brain when confronted with stuff 3500 years older than the internet:

Last time I checked Snapchat, Gunnar and Martha had both opened my video and now it's been, like, two hours so WHY haven't anyone responded to it? It was SO funny, with the mustache-filter and my voice, like, super deep.. They probably watched it and didn't get it or maybe they thought it was lame, and too soon or some bullshit like that.. Like I'm the only one without racial sensitivity in class?! And now on Monday, everyone is either going to totally ignore me, or completely attack me and maybe even tell Ralph I'm making fun of him for being part-Ghanese. And Ralph is so adorable when he runs with his hand holding up his jeans because he doesn't want to wear a belt, and I remember the way he looked at me when I made my dramatic entrance at Beate's going away-party, by the way - WHERE did that top go?, I bet mom threw it out when she discovered the puke or blood or whatever it was on it - STUPID COW, I miss that top. Is that supposed to be a boat? That's hilariuos, I should make an incredible Snap-video now, like zooming in on the boat and adding my head in to be, like, the crew, and then write "Just sailing to my death of boredom", HAHAHA.



DEAD

Completely ignoring my own instincts, I finally opened the doors and went into the great entrance hall of Hammersmith & Kahn. A rush of ventilated air blew down my perfectly styled hairdo, and I awkwardly jumped a few steps further in, frantically wiping aside the escaped hairs in my eyes. I immediately regretted my decision, looking around and discovering the snake of a line over a hundred people long. This was going to take most of the day, and optimistically I had not packed anything for lunch. Something brushed my back, and I quickly made for the back of the line, but when I looked back, safely installed, there was no one. It must have been the automatic doors opening, then. After a while, I fell into the same paper-dry rhythm of steps, the atmosphere settling once more, slowly draining all energy and thought. For a room this big, the sounds were somehow more muffled and intimate, as if everyone were made aware of their own acoustic influence, and thus held it back, swallowed in sweaty suits and newspapers unopened. I needed to pee, but to risk my place in the line now was out of the question. Another five people had joined the line behind me. At least, I think it was five - it was hard to remember when they had arrived, or if they had made any type of noise or disturbance at all. I resisted the urge to turn around again for fear of discovering the same *absence* from earlier, but I was more sure this time that I was no longer the last man in line. When I reached the first landing of the staircase, a natural opportunity arrived for a glance back. Relief flooded through me, as the entire entrance hall was packed to the brim with people. Some were looking up at me, but most faces were turned away in thought and concentration. The woman directly behind me was dwarfishly short, although even *thinking* that term gave me a shameful blush, so I sheepishly winked at her and faced forward again. I checked my watch, another hour to go and it would probably be my turn, given the length of the interviews so far. And it was then I realised that none of the candidates had come back out. The line just kept going forward, one person at a time, slowly but determinately. I could always leave, try another company another day, but something held me back, something like stubbornness or curiosity. The door at the end of the corridor kept swallowing people, at a quicker interval I noticed, as if something had spurred it on. This was getting exciting. I went through the opening line in my head, wiping a clammy hand on my thigh, plucking some lint off my shoulder, doing the same rituals as the rest of the line when they came this close. Just four remained in front of me now. My tummy rumbled loudly, making the man in front of me shift somewhat, but no other reaction came. Embarrassment now added to my nerves, I finally started to get impatient. The door opened again, an arm waved the next person in, and quietly shut again. I closed my eyes, concentrating on my line - "*Hey, I'm Daniel, any last wishes?*"



ROCK

A game of whispers among rocks, passed unnoticed from hard surface to brittle surface. This is how Philomena Von Trim imagined conversations underfoot as she walked the grounds of the abbye. All the miniscule cracks and pops as gossip and scandal was laid bare to every stone and pebble around. She knew she was the only human being with the ability to understand the life of the hard earth, and how rude everyone else was to trampel ungratefully around as if nothing held them up. She was careful not to look down as she moved, letting her bare feet do the listening. She felt them strain and moan as her enormous weight pushed them down, but they were also quick to forget, and as soon as she had passed, they went back to whispering again. Over the years she had learnt so much about the world outside the abbye, a place she had never seen, by walking the grounds. She knew more about the sisters and Mother Superior than she frankly needed, but the wealth of knowledge made her feel good, and she could help her friends more easily now that she knew about their concerns and hopes without the delay of a trusted conversation. She had aquired a reputation of being touched by God, and the abbye started recieving pilgrims eager for a blessing of knowledge. Philomena refused them all, never meaning to extend her special secret beyond the convent. Knowing about the outer world, and actually meeting it, are completely different things. Also, the stones never stopped whispering, and sometimes the shock of a certain truth could overwhelm her completely, leaving her sick with fever, sleeping for days. Yet she would continue the walks for the rest of her life, silently in awe of the endlessness of changes.



STAY

The opposite of an elemental force is not the remnants of the material stubbornly refusing the force's concentrated power to obliterate, it is however what exists the milliseconds before the strike hits. The spacetime completely unmolested by, or even uninterested in, the devastation of it's being.

One such elemental force is called Ned. His aspect is chocolate-driven. His powerful impacts are felt throughout the building when his wrath is made manifest. This happens every Wednesday, when the nurse arrives. They always find his contraband of sweets, however expertly hidden. Ned suspects they are in league with his nemesis, the Cauliflower. Ned's powers grow at night. He can actually see in the dark, if he concentrates really hard and adjusts his vision by staring into a corner for a long time. Then he takes out his well deserved treasures and puts some of them in his bespoke chocolate-eating hole, while stealthily moving around in search of a new hiding place either on the floor or in the ceiling. The Cauliflower-nurses have a tendency to start looking around at furniture-level, where Ned never really spends much time, being an elemental force of Superior Elevation and Profound Understanding. The rest of the week, Ned concerns himself with alterior versions of being and existing, alternating between the two as it pleases him. Bacterial interruptions in his flow, so called *family visits*, immediately deflates his genius, rendering him corporally bound in a sitting position, unable to conjure his Banishing Spell, but instead heightening his aural comprehension to a point where language erupts unhindered. Ned loves and hates voices in equal measure, making it extremely difficult to choose his own. The anticipation of one, in the aforementioned millisecond before the strike, is his favorite feeling, and this makes him grin widely with his facial image. As to the devastation that follows... well, his mother is very proud of him nomatter what.



LIVE

And here we are, my darling, finally in the ground. Are your feet cold? No matter. You will soon forget, I imagine. They really dug us a fine cairn, didn't they? Very fine indeed. Spacious, solid and with pretty white stones glittering like stars in the ceiling, I like that. Yes, this will do nicely for us. It took us a while to get here, didn't it love? Oh, my, didn't it just? First, they drag us out from the hut, all bloody and shredded to pieces, you even lost your head, you remember? Haha, they really made a mess, those animals. Not to worry dear, you still look beautiful to me. Then the sea came to claim us, and we floated around in the shallows for days. I hated that, I have to be honest, I was never a strong swimmer - as you well know. All that tangled seaweed and slimy fish. Bah. However, it did give us an interesting complexion, don't you think? A certain angelic likeness almost, especially you my darling, I really must say. Then the flood season brought us back on land, and wasn't that a relief? It felt so refreshing to dry out again. And those clever birds circling above us, drawing our relatives to find us. Oh, what a happy sound, those wails and cries. They had really missed us, wouldn't you say? And so, our journey came to an end. I'm so glad it did. It would have been terribly boring if it just went on. What did you say, love? *Shut up?!*



Sketchwork and illustrations

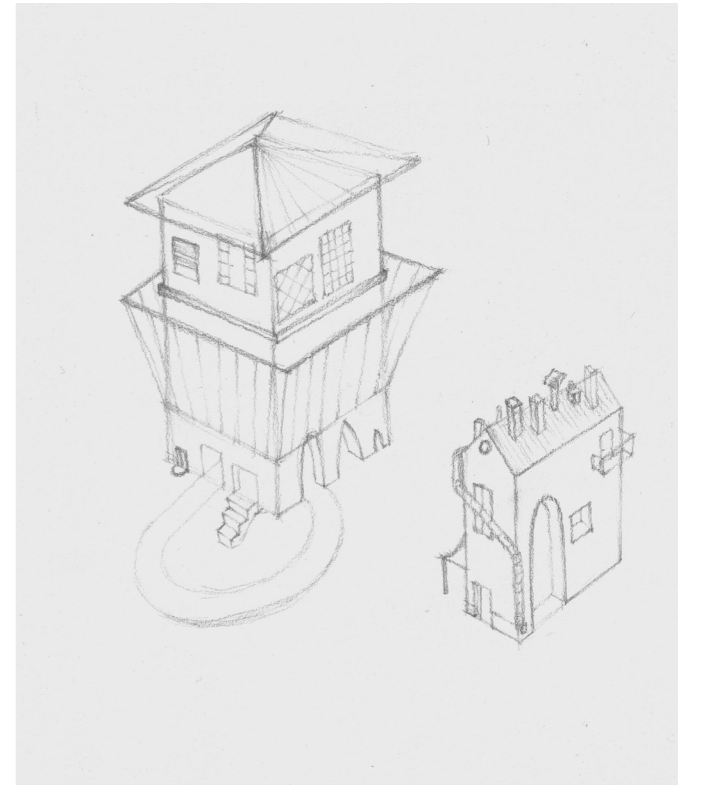
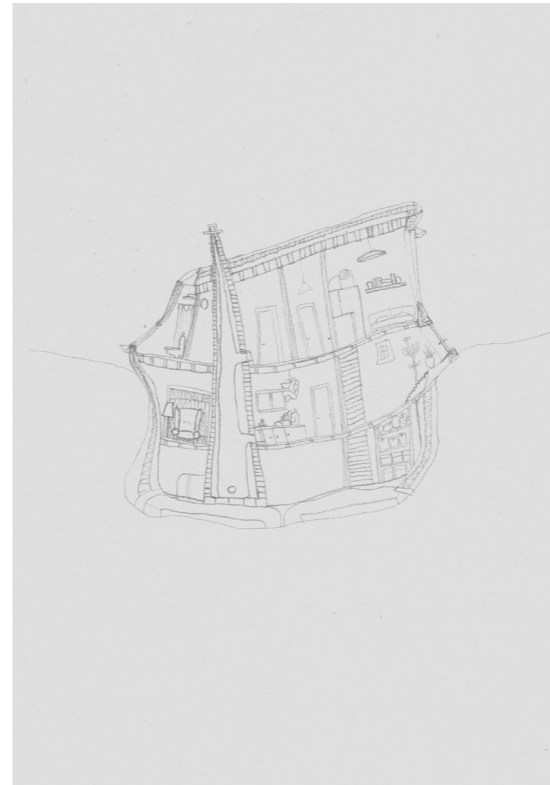
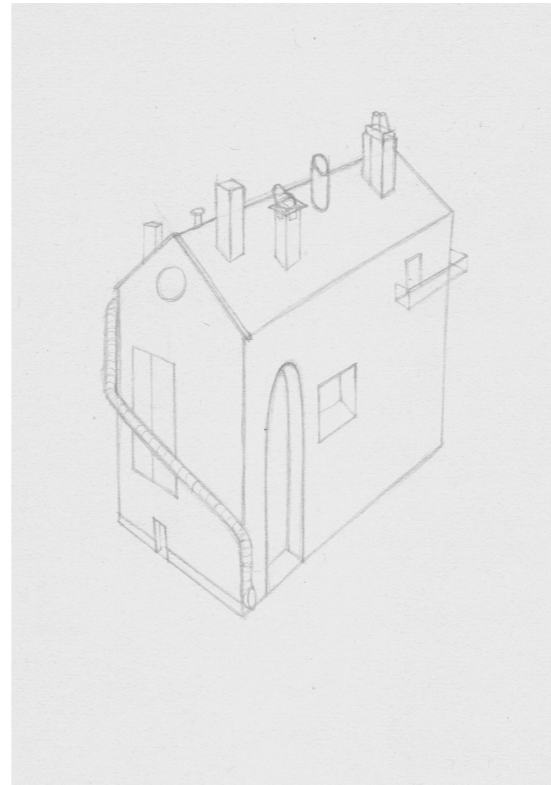
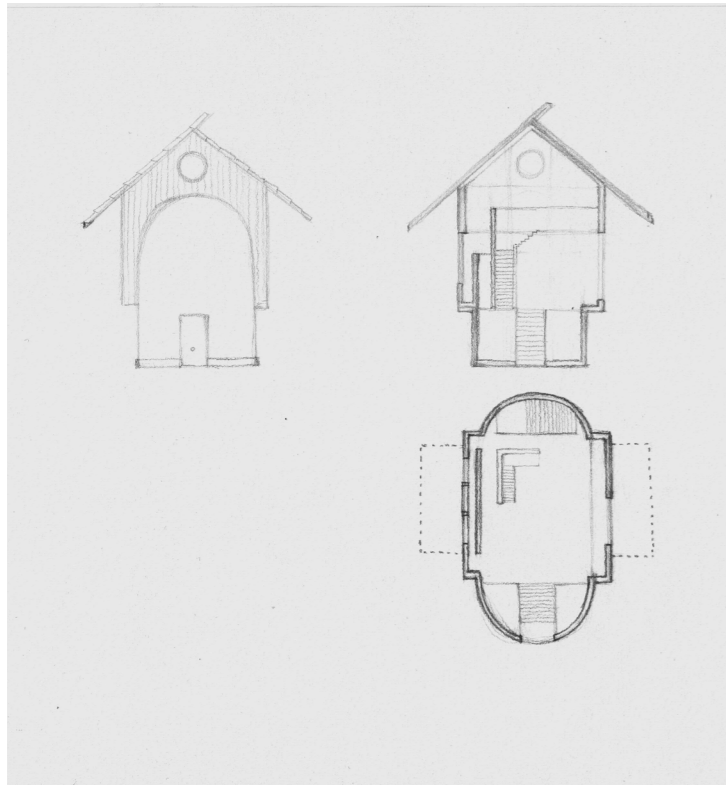

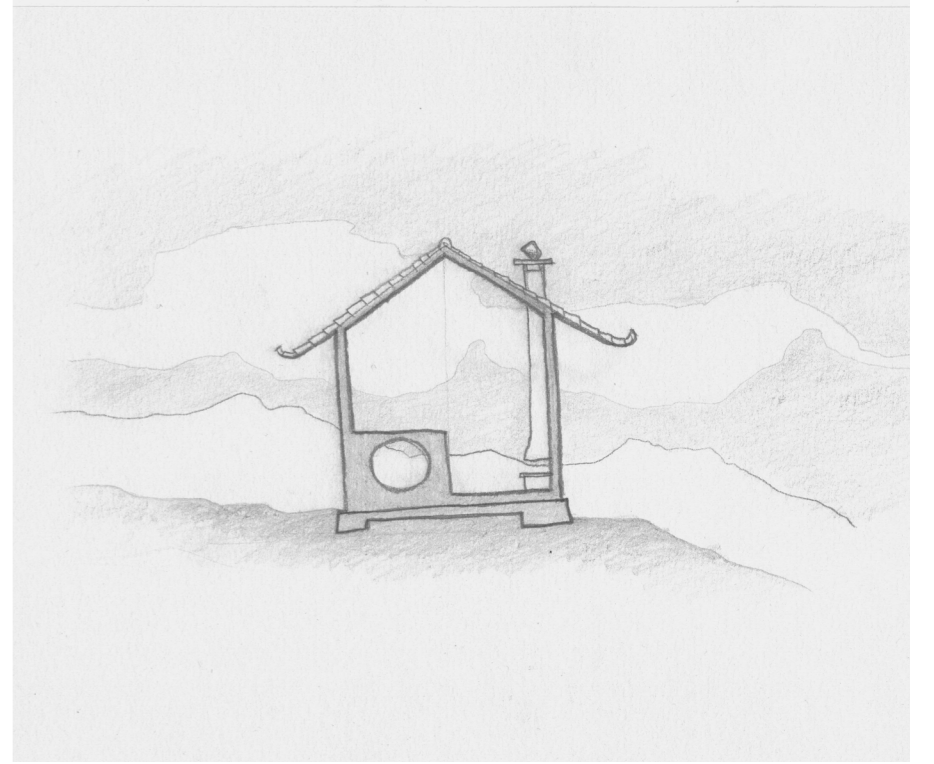
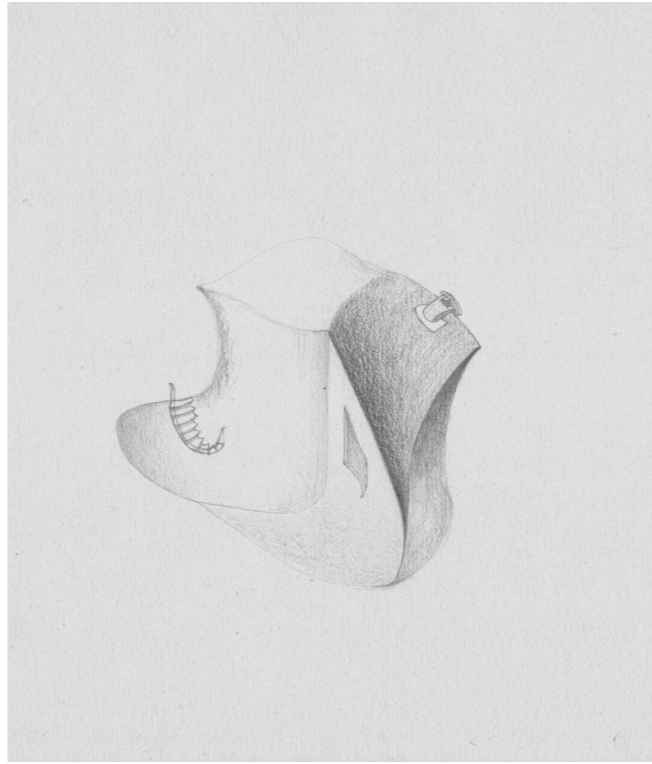
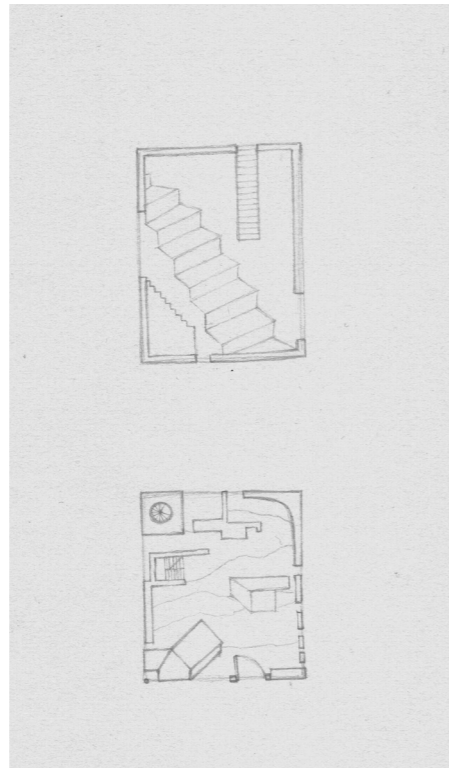

WELL,
SHIT



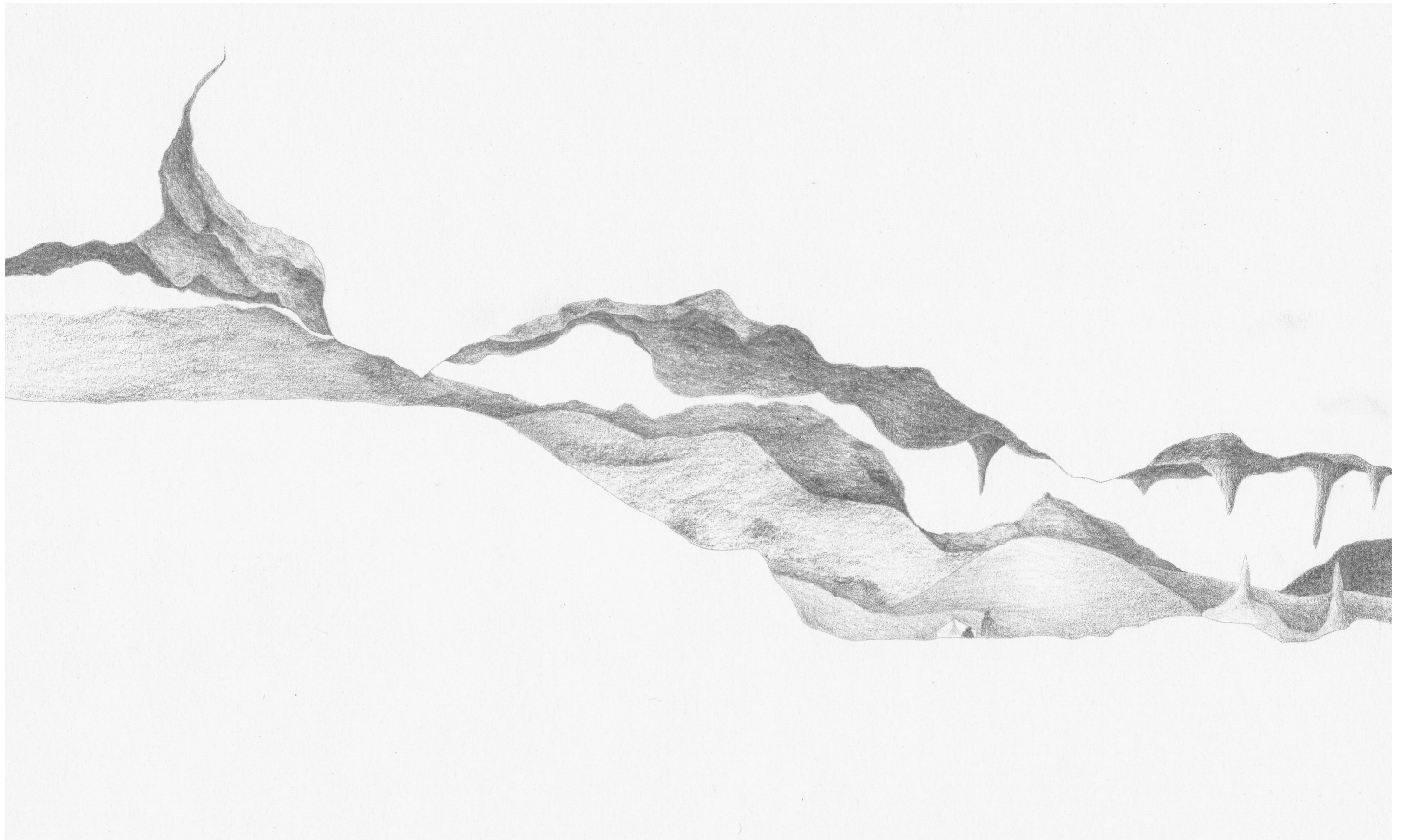



Scene from the Cabin of Nudity



Scene from the Museum of Bad Conscience

Modelwork



House Afraid of Rain

A house lifting its head barely above the ground, the large roof making 90% of its building mass, and very low windows peeking just above the ground. The man living in the house has never understood its timid appearance, and has taken it for architectural experimentation from a period where such things were allowed, and people could pay for it. But the house is just very afraid of rain. A pity, then, to be built in England.



Tower closed

Due to the menacing pandemic, the structure combining diving tower and horse race stand was built with closed walls. The elected officials were terribly proud, certain this would put their town on the map.

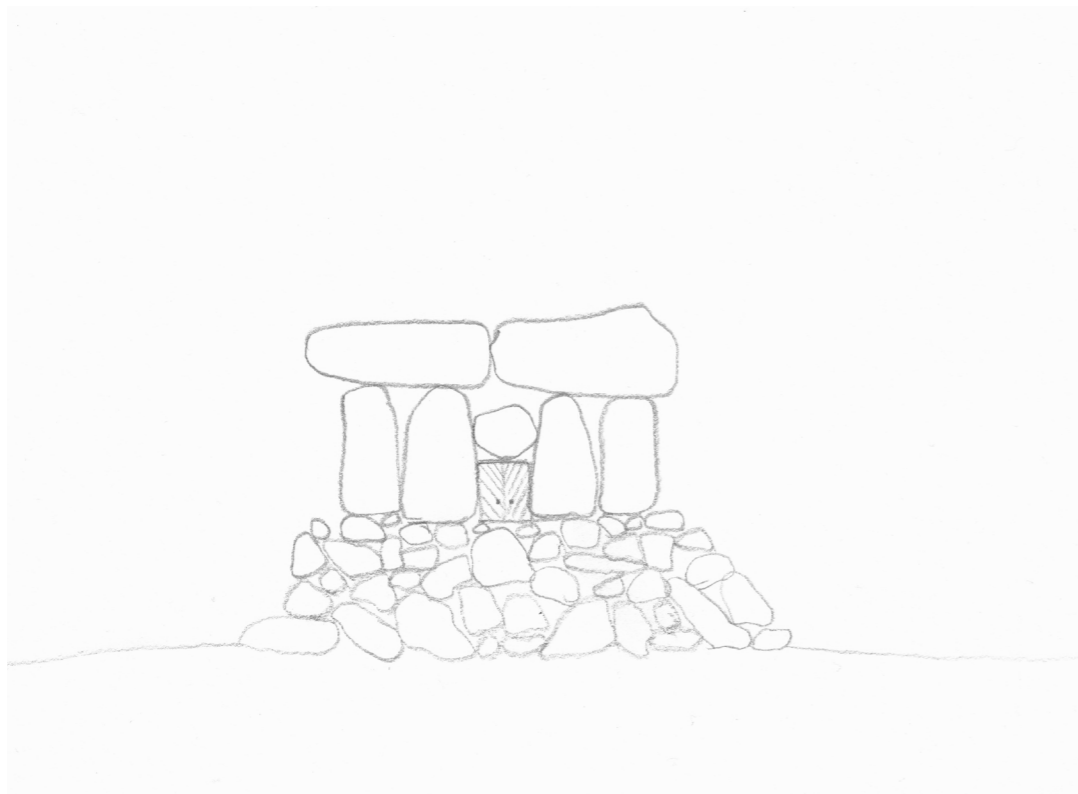

House of Depression

The heaviness of the world is felt by all, thanks to the ever illusive force called gravity. Dragging us steadily down to its core, where we meet in the centre of the earth. And what happens there? The greatest hug in history. I could use one of those.



Stiletto farmhouse

Carton and balsa wood

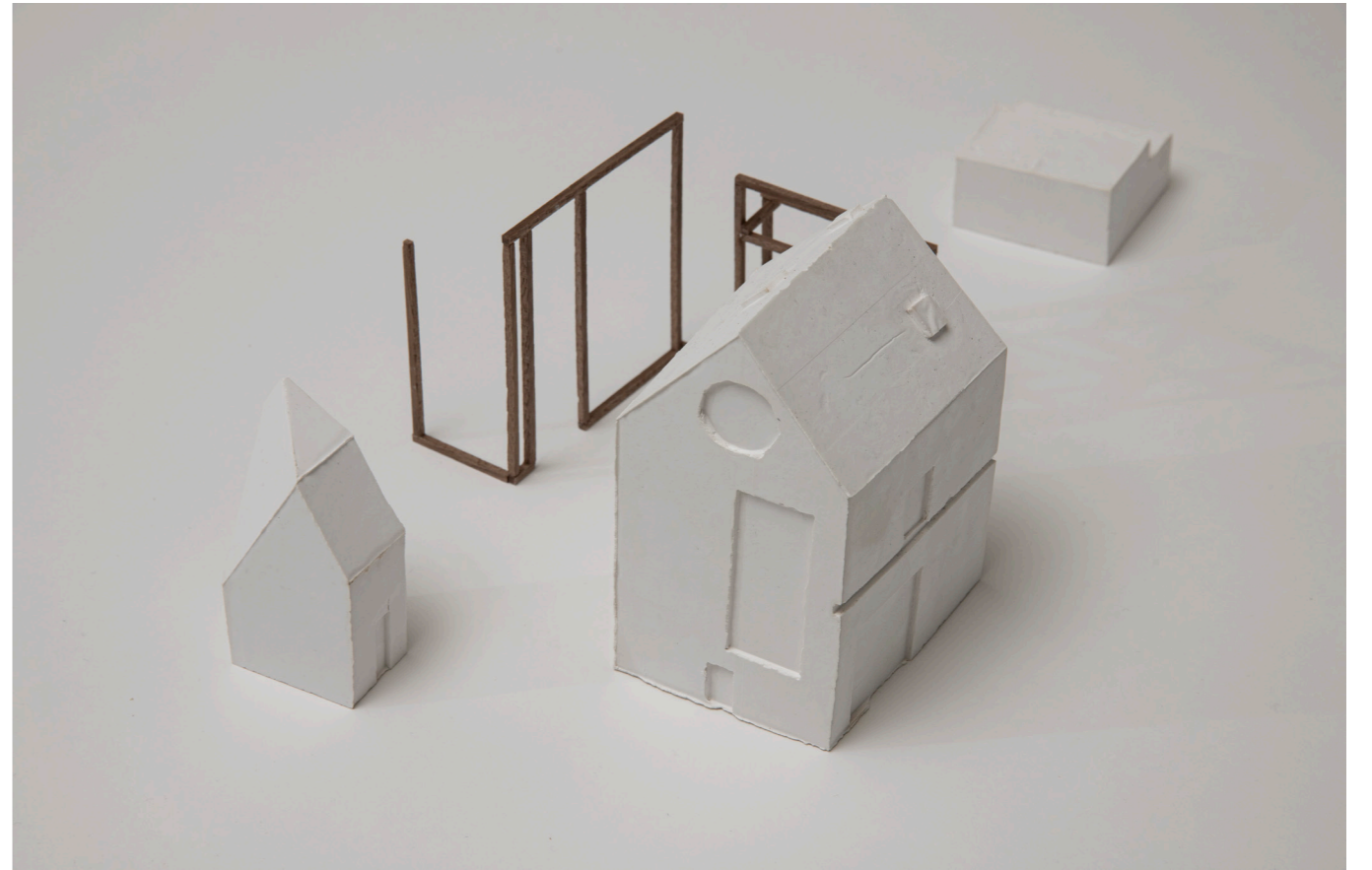
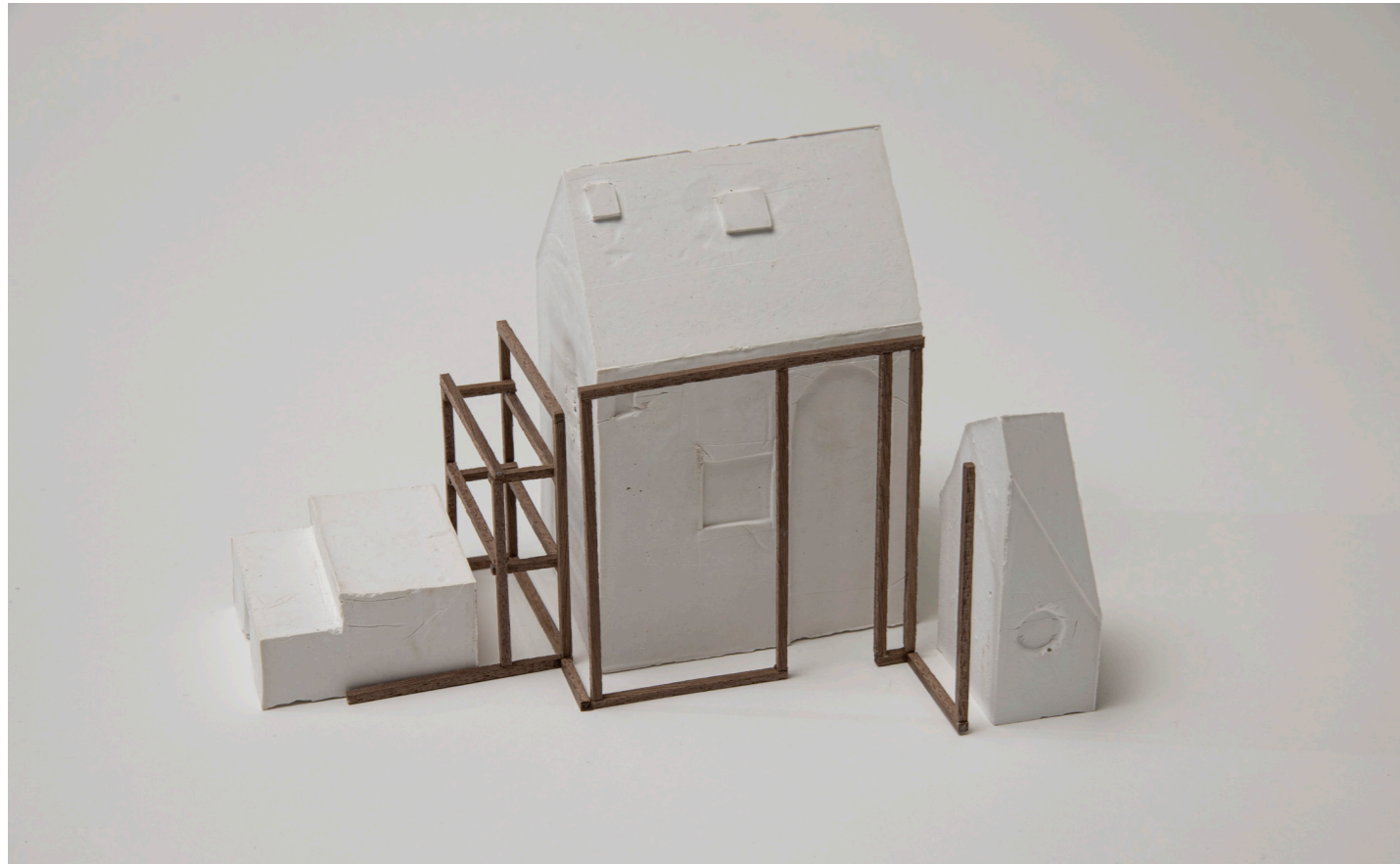

Plaster and wood

-but which came first?



Sentinels of slow-drying clay

Sometimes you just need someone to watch your back, standing guard so to speak - as you work, keeping the creative ideas from slipping away. And yes, sometimes your index finger needs to poke a hole in something.

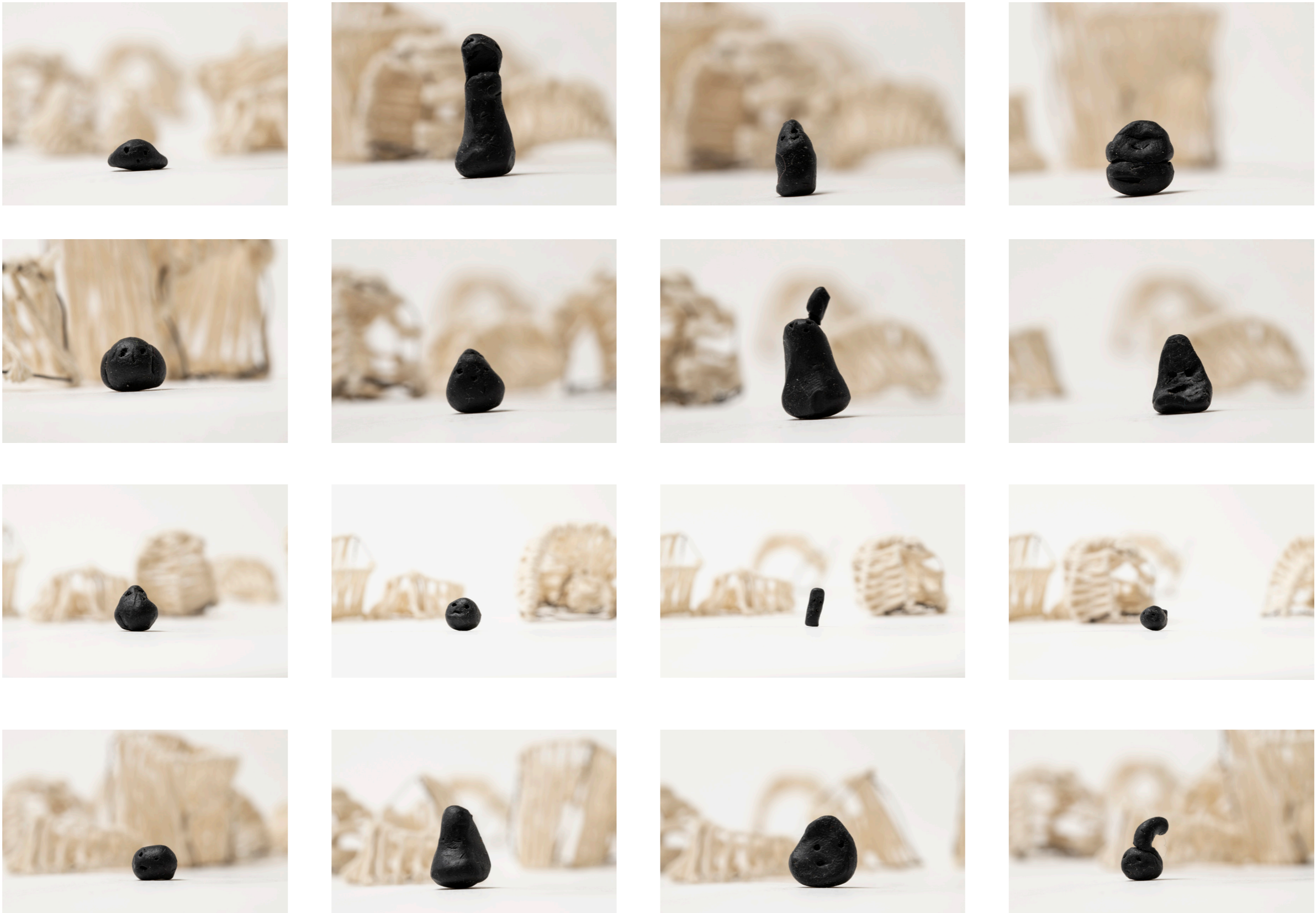

The stars

All the plasticine figures showed up for a photo shoot, some more shy than others of course. It looks like they really enjoy the wire- and twine-houses I made for them, judging by the hair and dust.





House of Postponing

Cardboard, wood and carton

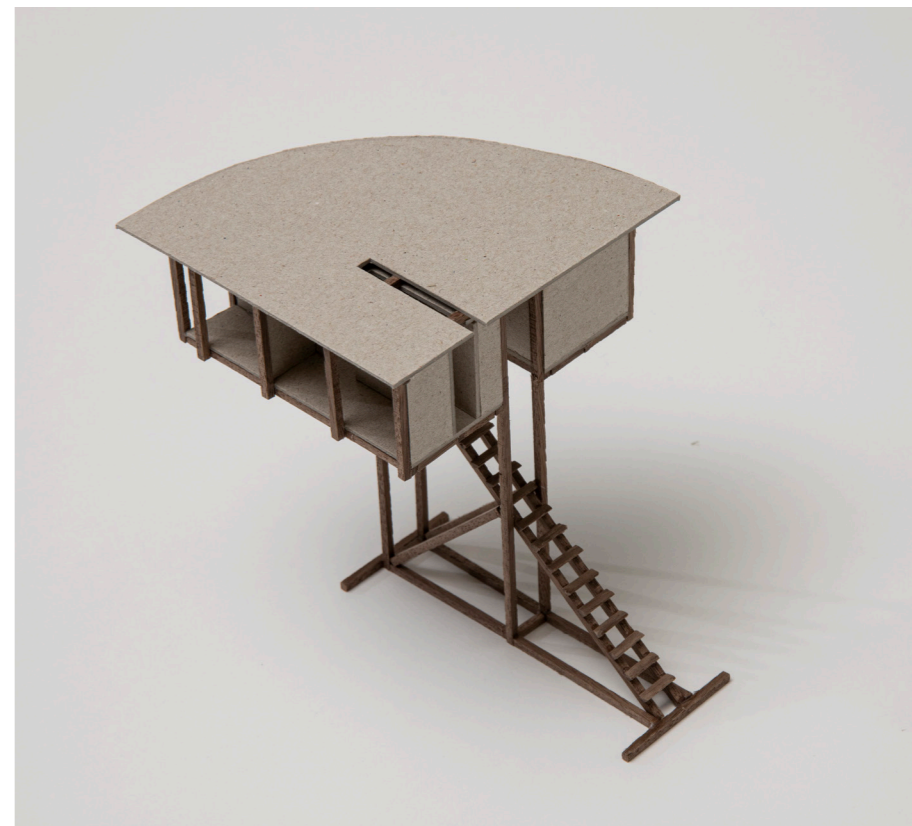

House of Ambition, beach version

Cardboard and wood



House with Antcolony

Balsa wood, plexiglass and soil

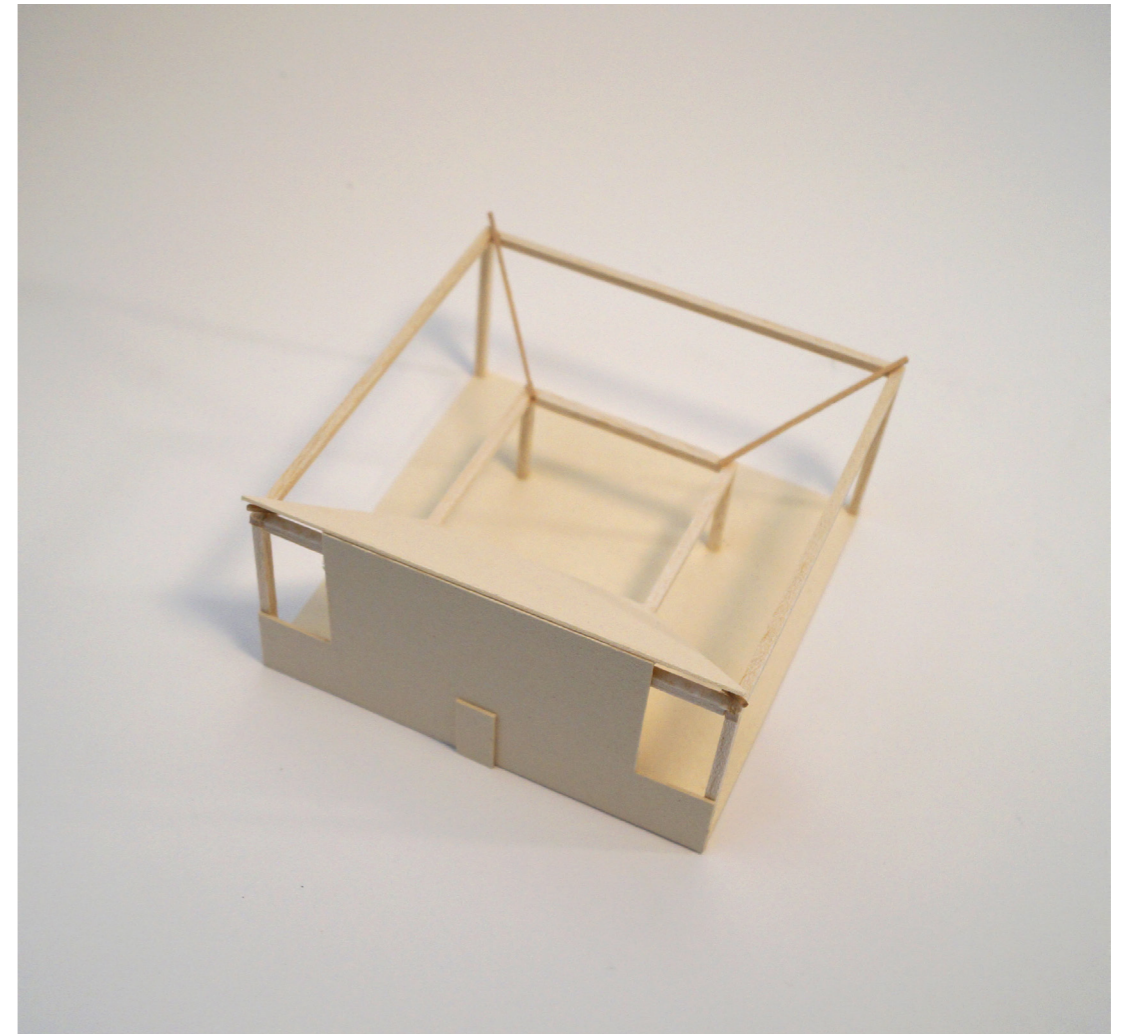
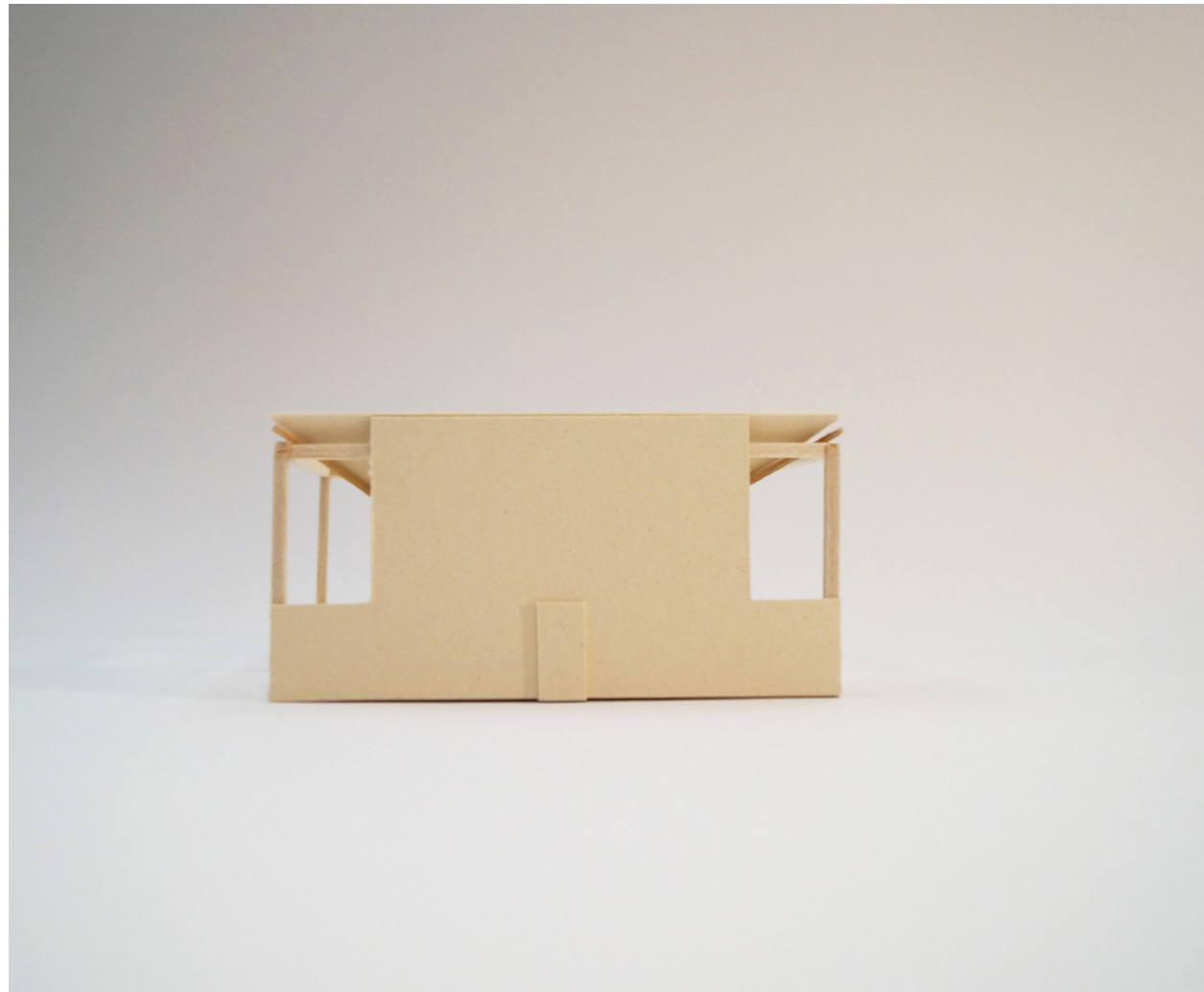

School of Repetition

Carton and balsa wood

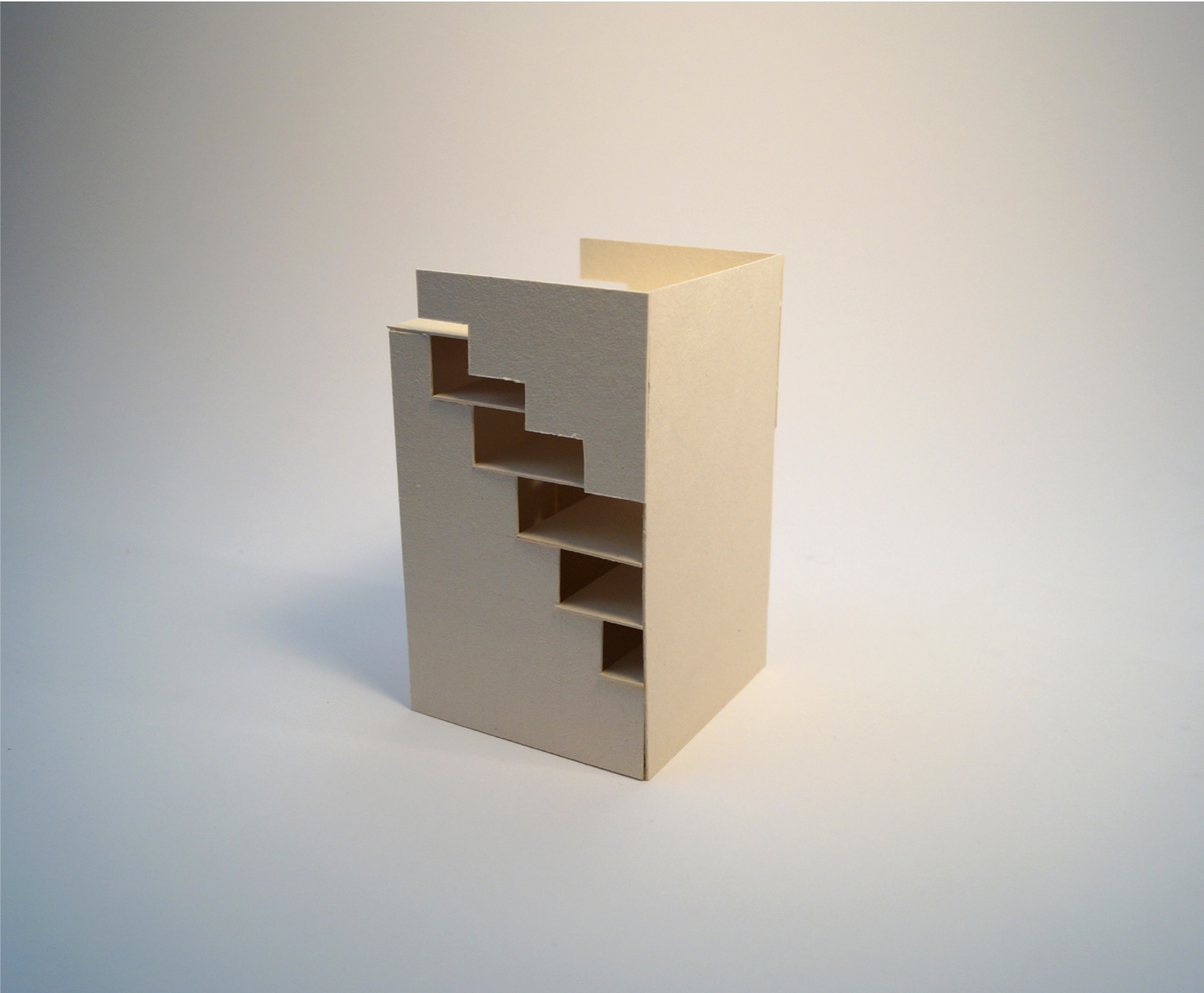

Hotel of Mischief

Carton

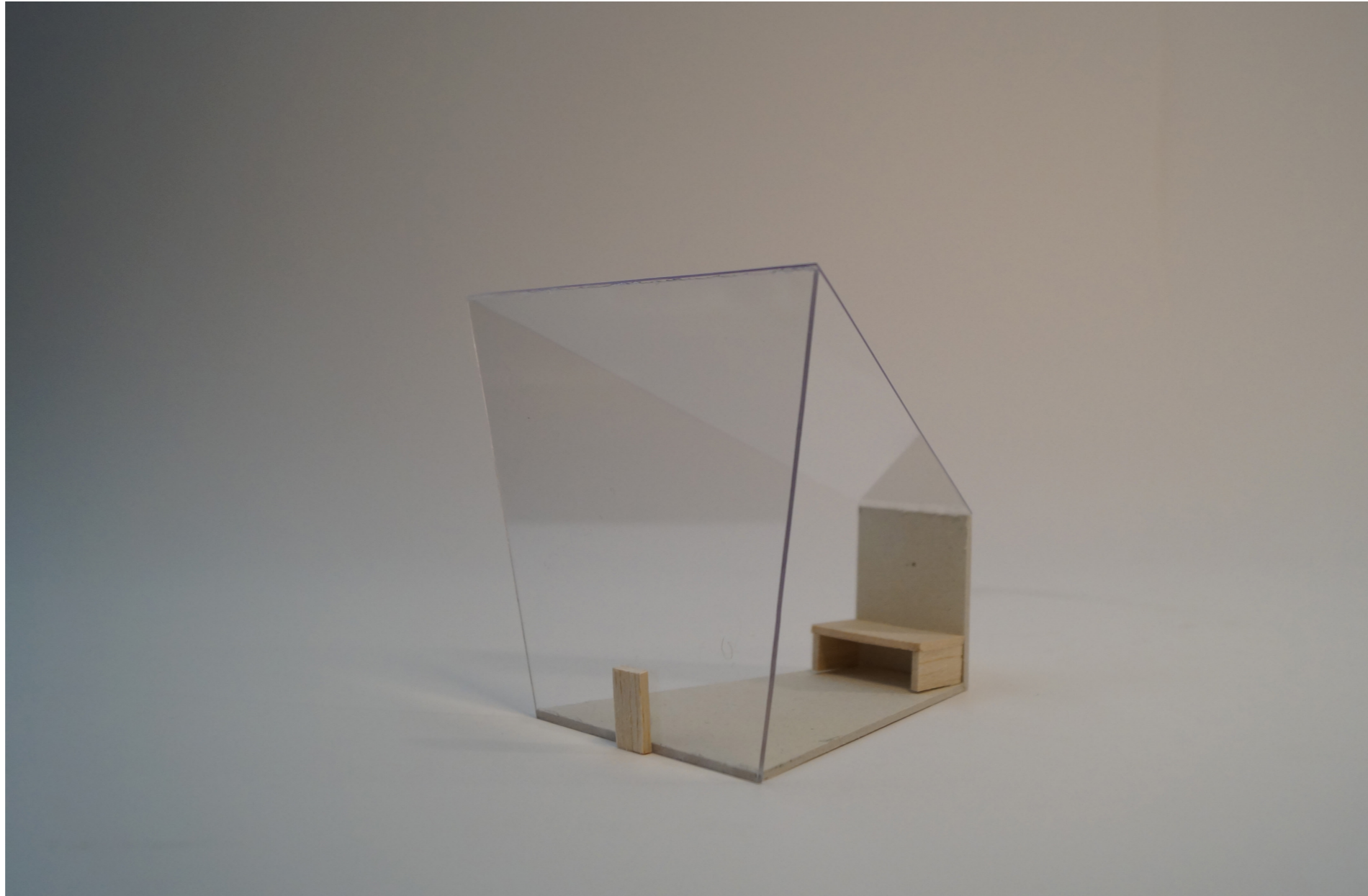

Theatre of Self Esteem

Plexiglass, cardboard and balsa wood



Courthouse of Crime

Carton, cardboard and balsa wood

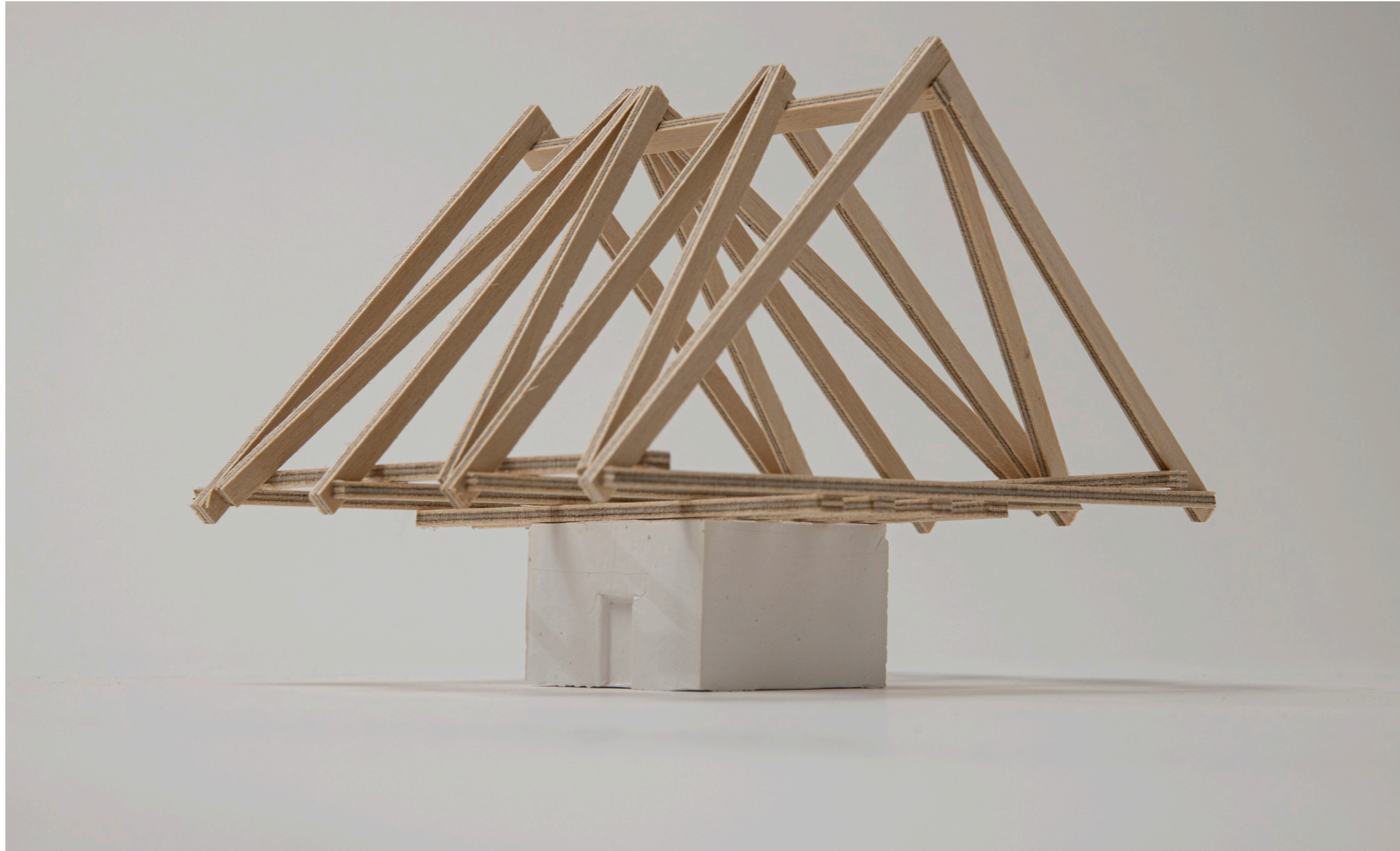

Cabin of Envy

Plaster and wood



Museum of Bad Conscience

Carton and wood



Bank of Money

Balsa wood and carton



Hospital of Help

Plaster and foam board