

BOOK OF MAKING

Diploma - Fall 2020

Anne Margrethe Sørseth

box

container

shell

beholder

cabinet

space

enabler

tower

house

structure

I look at all of my objects, on my desk, sorted into piles. Stones separated from branches and seashells from animal bones. I make a quick sketch, but not too specific. Then I start the making, the acting, and reacting, of the beholder. Sometimes I change my mind, swap the object for another. Other times the structure is perfect for the object. Ephemeral and fragile structures, like the landscapes they were taken from. Parts of a landscape that were only known to me. Now that they are elevated, presented for a possible new beholder, or for the object to behold back. The objects dwell in their structures, and the structures become new objects in themselves, new creatures trying to convey a message of the content inside.

001 Manifest
(The wall)

280 x 196 x 70 mm

Plaster

Birch

Acrylic sheet 1,5 mm

Timber strip 3 x 8 mm

Sea kale / *Crambe maritima*

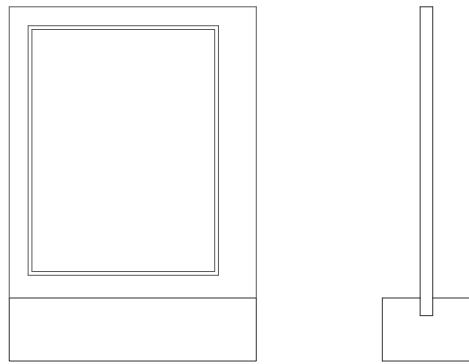

002 Compile
(The vertical landscape)

182 x 128 x 70 mm

Plaster
Birch

sea glass

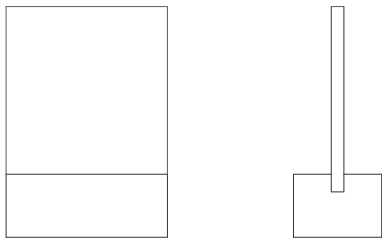

003 Catalogue
(The herbarium)

182 x 258 x mm

Plaster
Birch
Acrylic sheet 1,5 mm
Timber strip 1 x 3 mm

Sea thrift / *Armeria maritima*

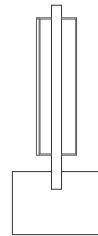
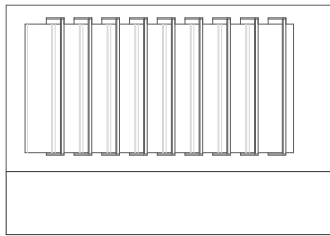

004 Protect
(The lair)

184 x 134 x 77 mm

Tracing paper 60g
Plywood 1,5 mm
Timber strip 3 x 3 / 1 x 3

Branch that looks like the head of a dragon

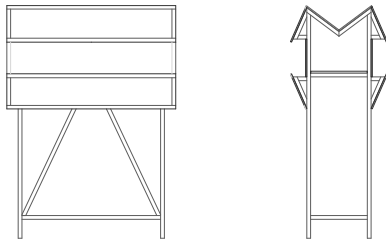

005 Parade
(The pavilion)

230 x 98 x 65 mm

Timber strip 3 x 8 mm / 1 x 3 mm
Tracing paper 60g
Plywood 1,5 mm

Shell of sea urchin /
Echinocardium cordatum

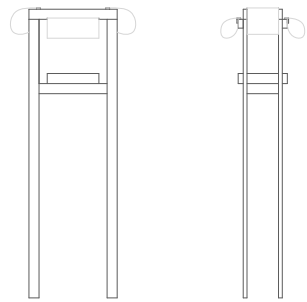

006 Indicate
(The snake in a box)

250 x 125 x 55 mm

Tracing paper 60g

Plywood 1,5 mm

Timber strip 1 x 3 mm / 2 x 5 mm

A root

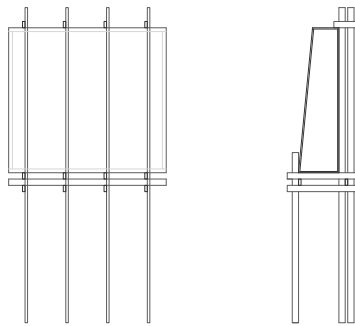

007 Store
(The shelf)

312 x 113 x 57 mm

Timber strip 5 x 5 mm
Wood round rod 2 mm diameter
Plywood 1,5 mm

Various stones and shells

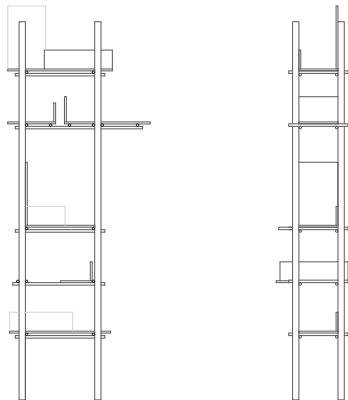

008 Conceal and Reveal
(the cabinet)

204 x 142 x 32 mm

Plywood 1,5 mm
Wood round rod 2 mm diameter
Timber strip 1 x 3 mm

A root

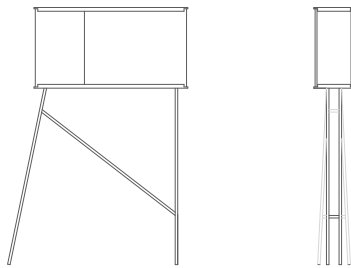

009 Contain
(The frame)

156 x 130 x 80 mm

Plywood 1,5 mm

Timber strip 5 x 5 mm / 2,5 x 6

A root

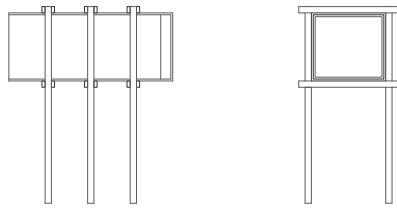

010 Reveal
(The singing cyclops)

233 x 120 x 50 mm

Timber strip 2 x 5 mm
Tracing paper 60g

Shell of common limpet /
Patella vulgata

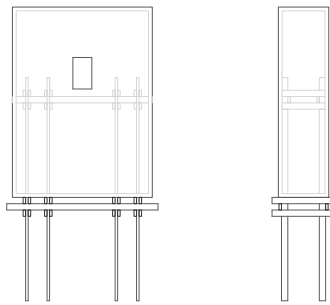

011 Keep
(The whispering cyclops)

233 x 120 x 50 mm

Timber strip 2 x 5 mm / 2 x 10 mm
Plywood 1,5 mm

Shell of common limpet /
Patella vulgata

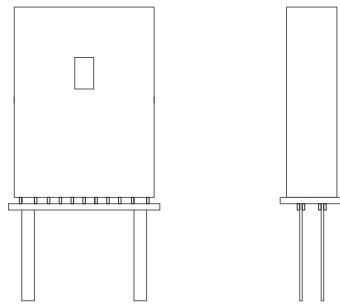

012 Protect
(The mute cyclops)

233 x 135 x 55 mm

material: timber strip 2,5 mm and
plaster

containing: shell of common limpet /
Patella vulgata

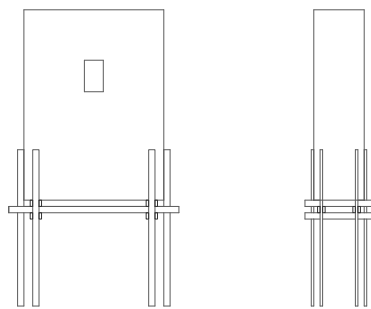

013 Preserve
(the no curiosity cabinet)

307 x 74 x 50 mm

Plywood 1,5 mm
Acrylic sheet 1,5 mm
Acrylic rod 2 mm
Timber strip 5 x 5 mm

Two common whelk /
Buccinum undatum

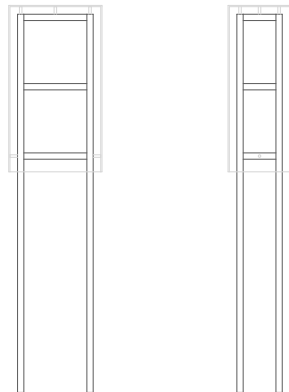

014 Exhibit
(The no curiosity cabinet 2)

250 x 102 x 45 mm

Wood round rod 2 mm diameter
Timber strip 3 x 8 mm
Acrylic sheet 1,5 mm

European searocket /
Cakile maritima
common bird's-foot trefoil /
Lotus corniculatus

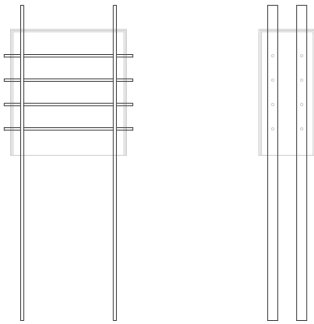

015 Relation
(The ecco)

263 x 52 x 44 / 233 x 50 x 44 mm

Plywood 1,5 mm
Timber strip 2 x 2 mm

Piece of driftwood

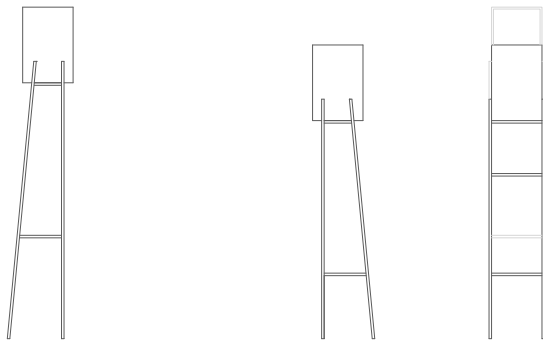

016 Collocation
(The perfect fit)

158/188 x 92 x 83 mm

Round rod 2 mm diameter
plaster

Stone

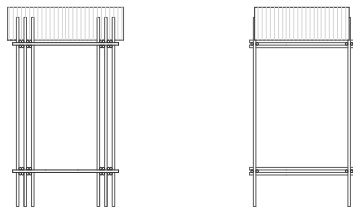

017 Shield
(The perfect fit 2)

208 x 60 x 58 mm

Round rod 2 mm diameter

Plaster

Acrylic corrugated sheet 6 mm

Stone

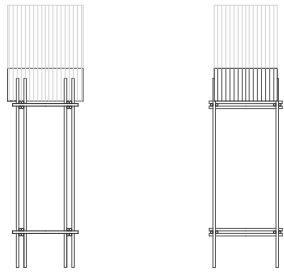

018 Archive
(The collector)

280 x 139 x 58 mm

Acrylic sheet 1,5 mm
Timber strip 3 x 3 mm

12 shells of sea urchin /
Echinocardium cordatum

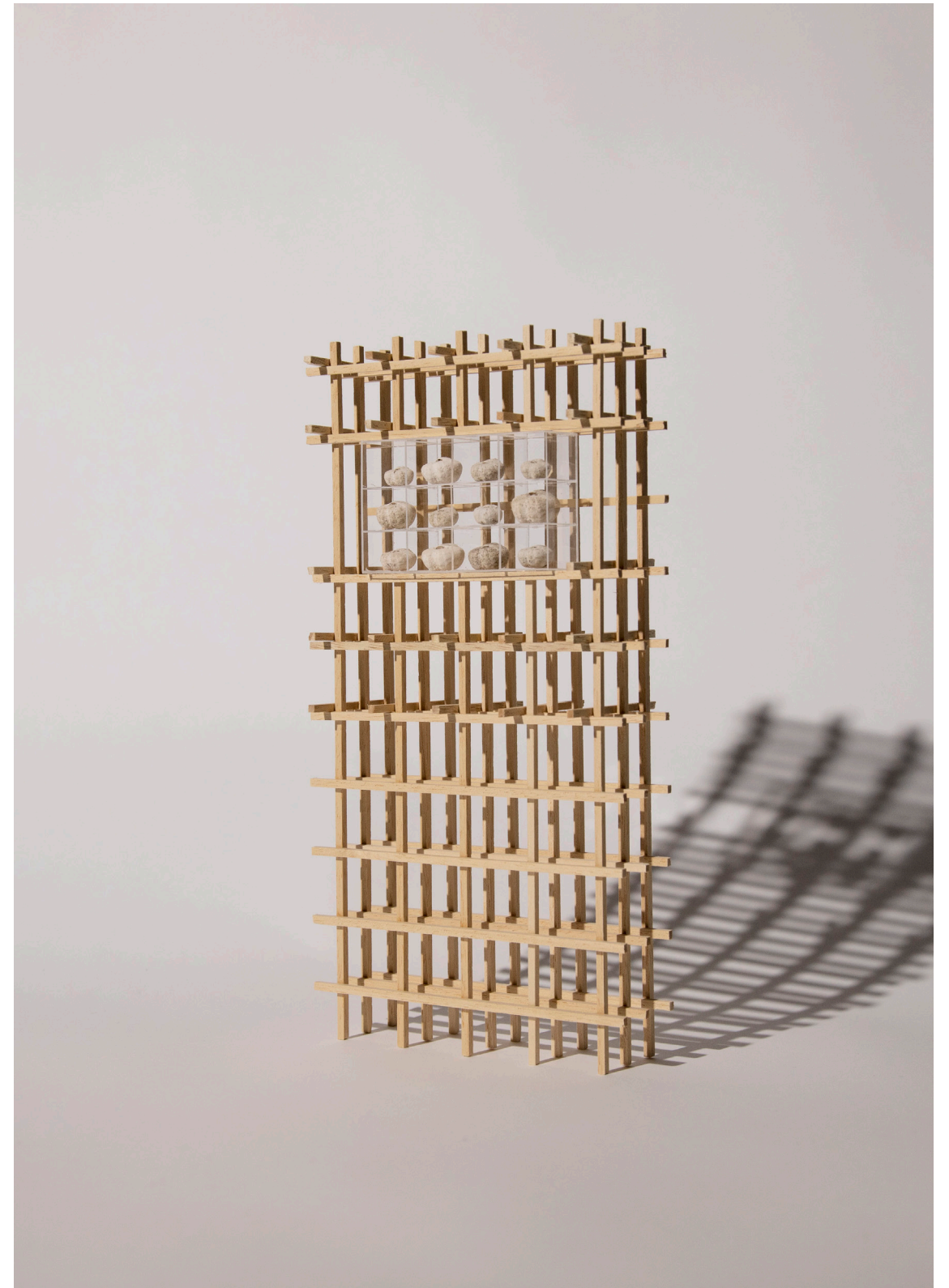
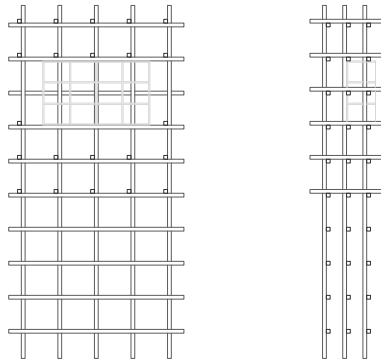

019 Foundation
(The enabler)

153/ 62 x 62 mm

Timber strip 1,5 x 5 mm

Stone with stripe

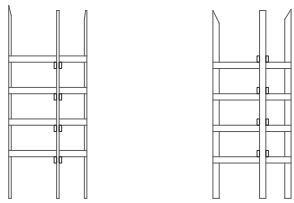

020 Scaffold
(The enabled)

166/ x 70 x 35 mm

Timber strip 1,5 x 5 mm

Stone with stripe

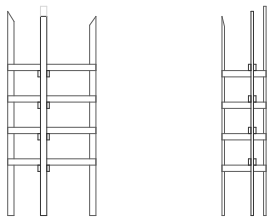

021 Display
(The no curiosity cabinet 3)

670 x 250 x 330 mm

Acrylic sheet 2 mm
Timber strip 18 x 18 mm
Brass screw 10 x 5 mm

Ferns

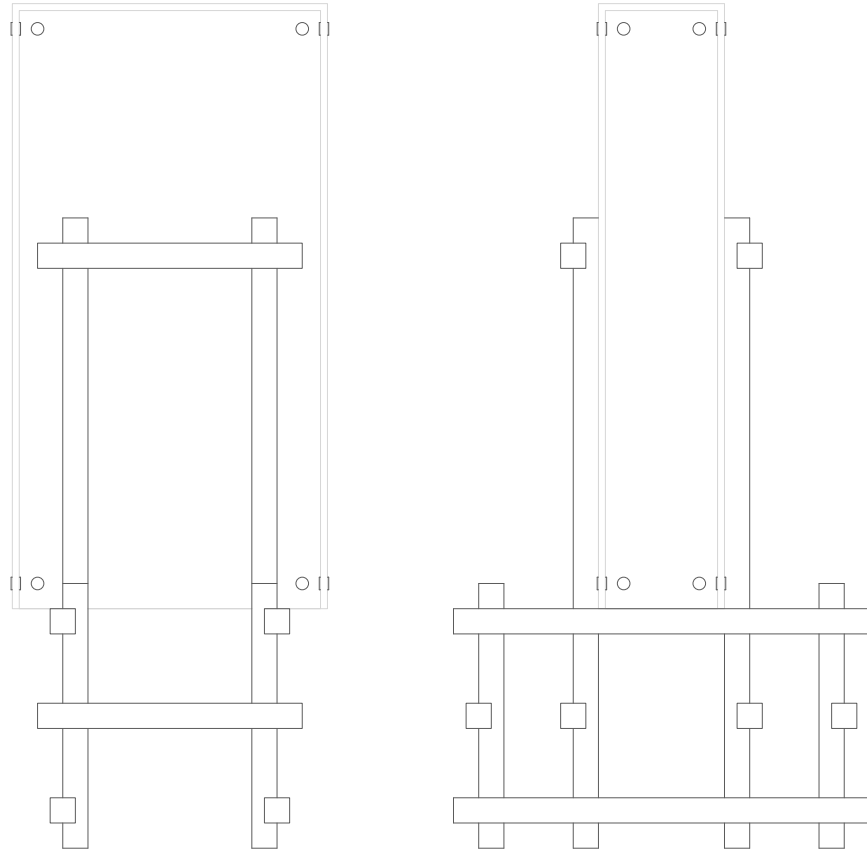

022 Suspense
(The fixture)

450 x 240 x 90 mm

Timber rod 10 mm

Red buoy

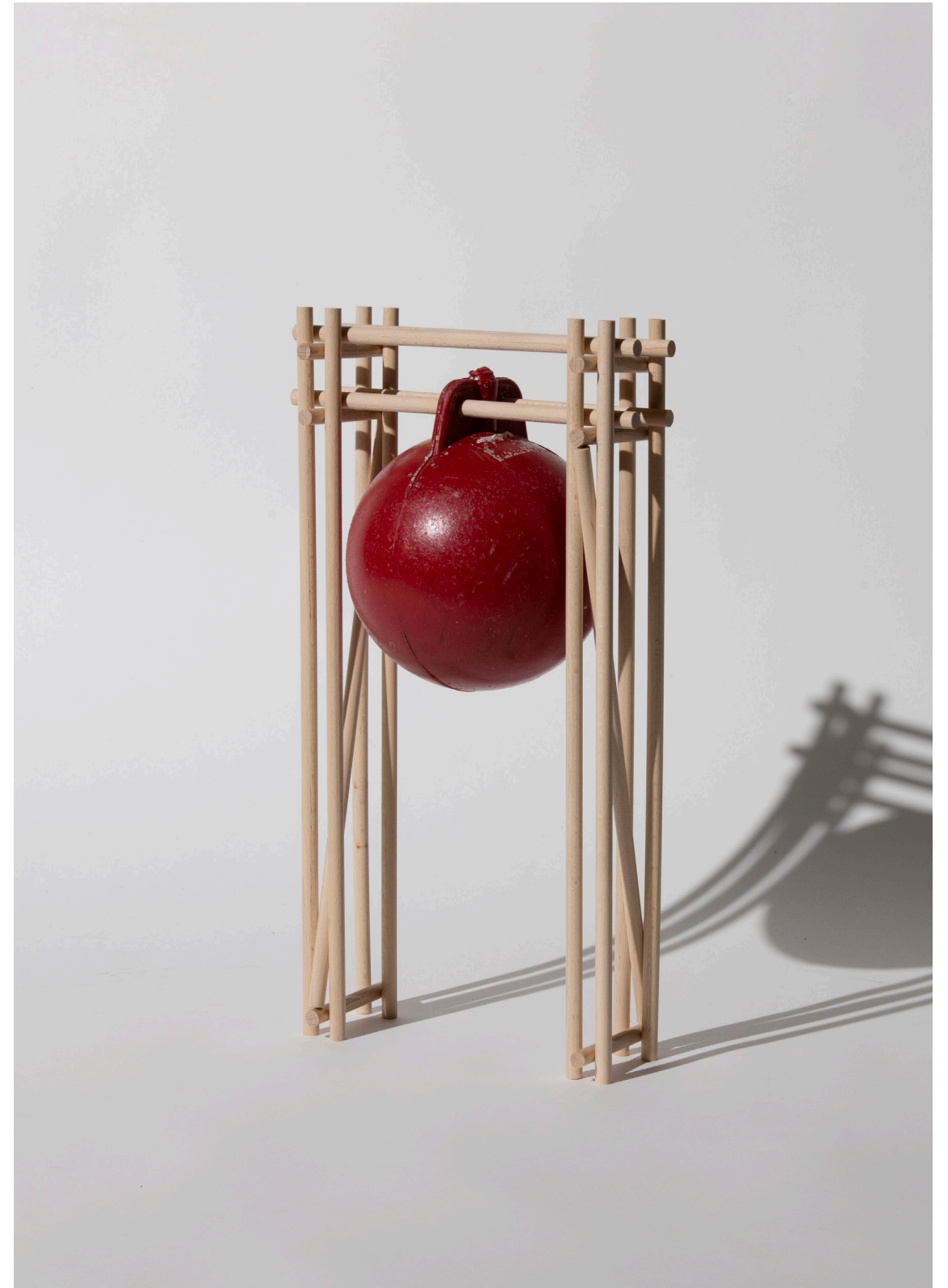
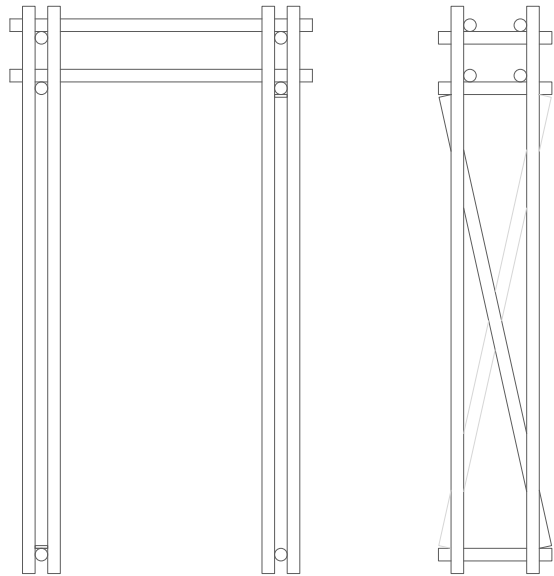

023 Travel (The beholder of beholders)

model 1:20
drawing 1:100

Acrylic sheet 1 mm
Timber strip 4 x 4 mm
Plywood 1,5 mm
Tracing paper 120g

22 structures with objects
6 stones
15 ferns

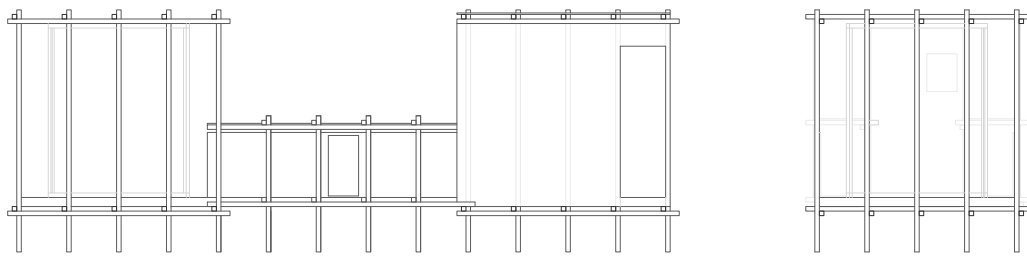

024 Return
(The beholder of beholders)

model 1:200

Timber strip 2 mm
Cardboard 1,5 mm



ARCHIVE



RECORDINGS

001

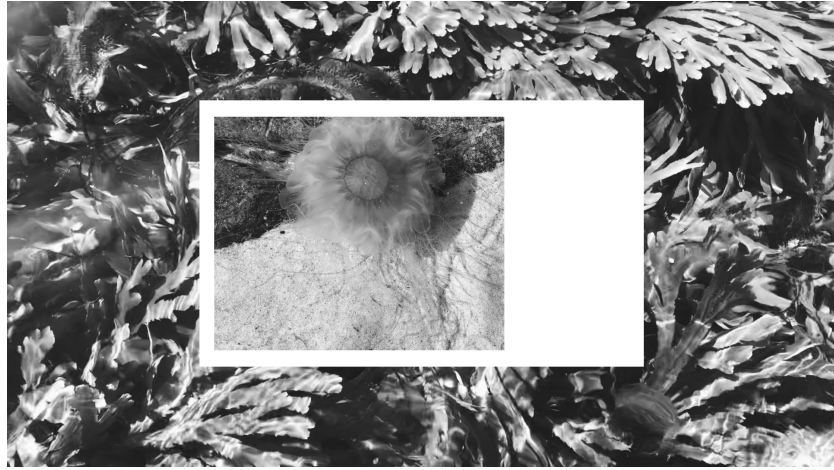

04:00

002



02:00

003

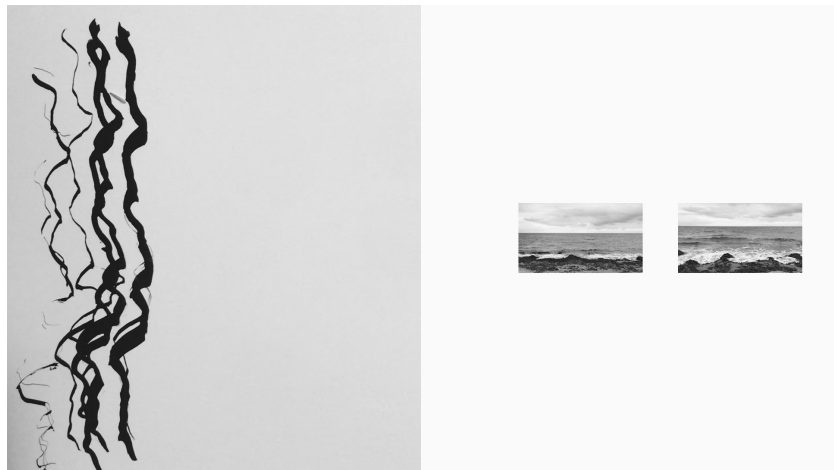

02:00

CONTAINERS AND TOOLS

004



Leather paper
Gray string
8 Binder clips

005



Leather paper
Gray string
4 Binder clips

006



Leather paper
Gray string

007



Wax string
Collected Reed

010



Plywood 5 mm
4 bolts 5mm
4 wing nuts 5mm
4 discs
cardboard 1,5 mm

008



Leather paper
Timber rod 10 mm
Gray string

011



Plywood 5 mm
Leather paper
Timber rod 10 mm
Gray string

009



Leather paper
Timber rod 10 mm
Gray string

012



Plywood 5 mm
Leather paper
Timber rod 10 mm
Gray string

SKETCHES

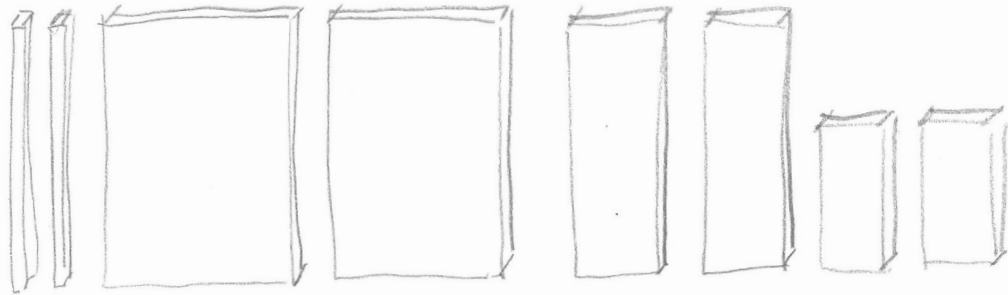

RULL MED
PAPPERSTOFF



SVL



TRÅD
GRÅ



NÅL

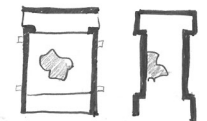
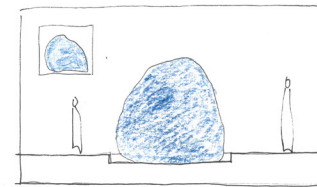
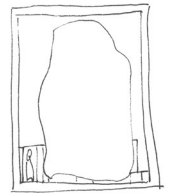
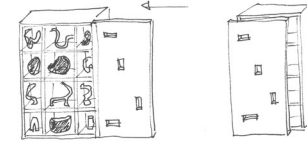
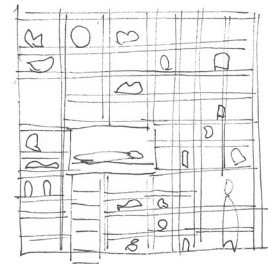

SPACE
FOR A
BRANCH

