

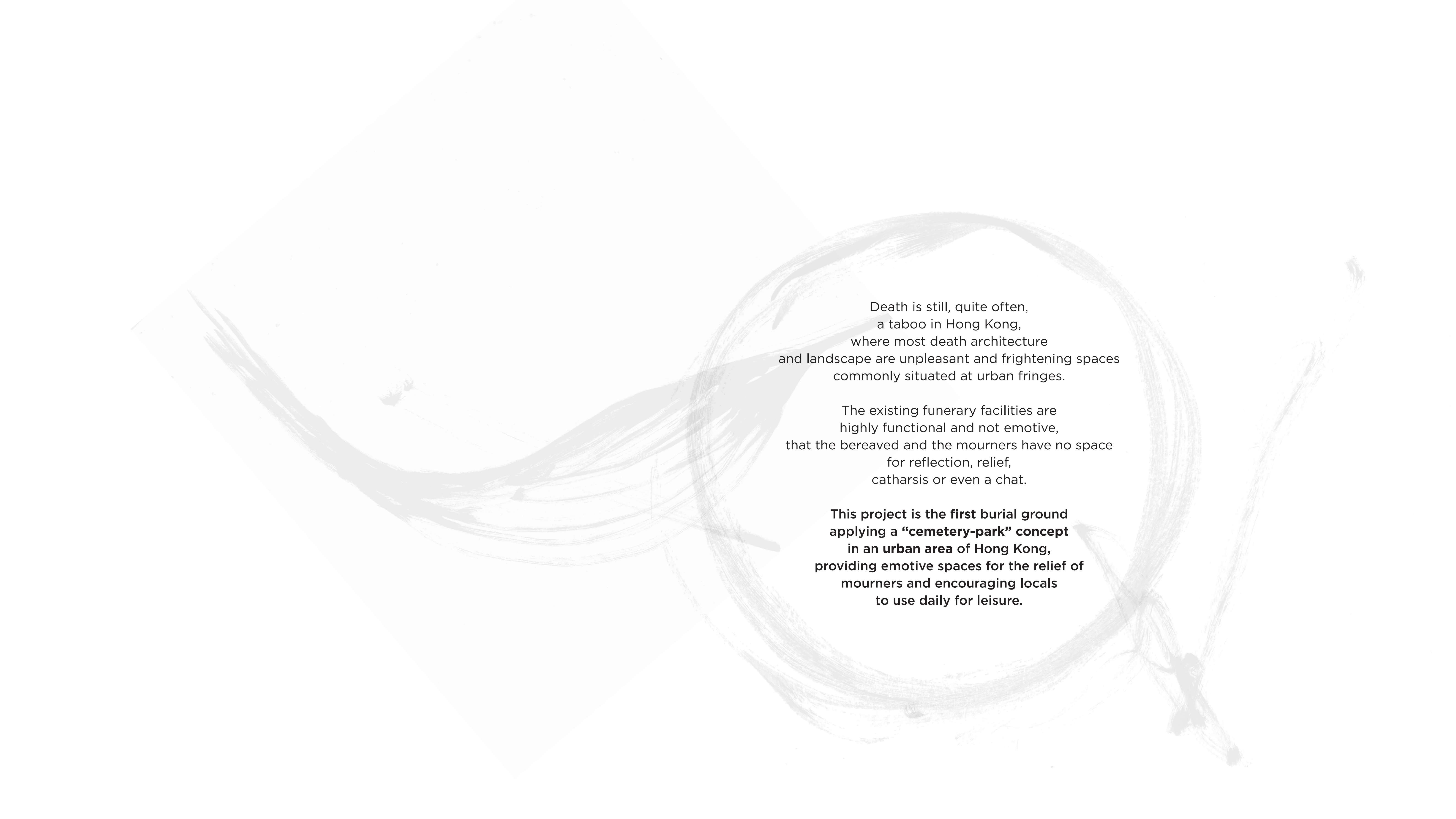

# after death

a multidimensional peace of mind

2017 SPRING DIPLOMA | MASTER IN LANDSCAPE ARCHITECTURE | VICKY CHIN WAI KONG  
AHO Oslo School of Architecture and Design, Institute of Landscape and Urbanism



Death is still, quite often,  
a taboo in Hong Kong,  
where most death architecture  
and landscape are unpleasant and frightening spaces  
commonly situated at urban fringes.

The existing funerary facilities are  
highly functional and not emotive,  
that the bereaved and the mourners have no space  
for reflection, relief,  
catharsis or even a chat.

**This project is the first burial ground  
applying a “cemetery-park” concept  
in an urban area of Hong Kong,  
providing emotive spaces for the relief of  
mourners and encouraging locals  
to use daily for leisure.**

CONTEXT AND PROBLEMATICS

DESIGN CONCEPT

SITE SELECTION

DESIGN STRATEGIES

THE DESIGN & PROCESS

PROJECT VISION



## Context and Problematics

- 1 TRADITION | TABOO
- 2 FEAR OF DEATH
- 3 DENSE | LIFELESS | SCARCITY OF SPACE
- 4 REMOTENESS OF FUNERARY FACILITIES
- 5 POPULATION SUFFERING FROM DEPRESSION

## CONTEXT AND PROBLEMATICS

DESIGN CONCEPT

SITE SELECTION

DESIGN STRATEGIES

THE DESIGN & PROCESS

PROJECT VISION

死

death | dead

死 朋 友 能 否





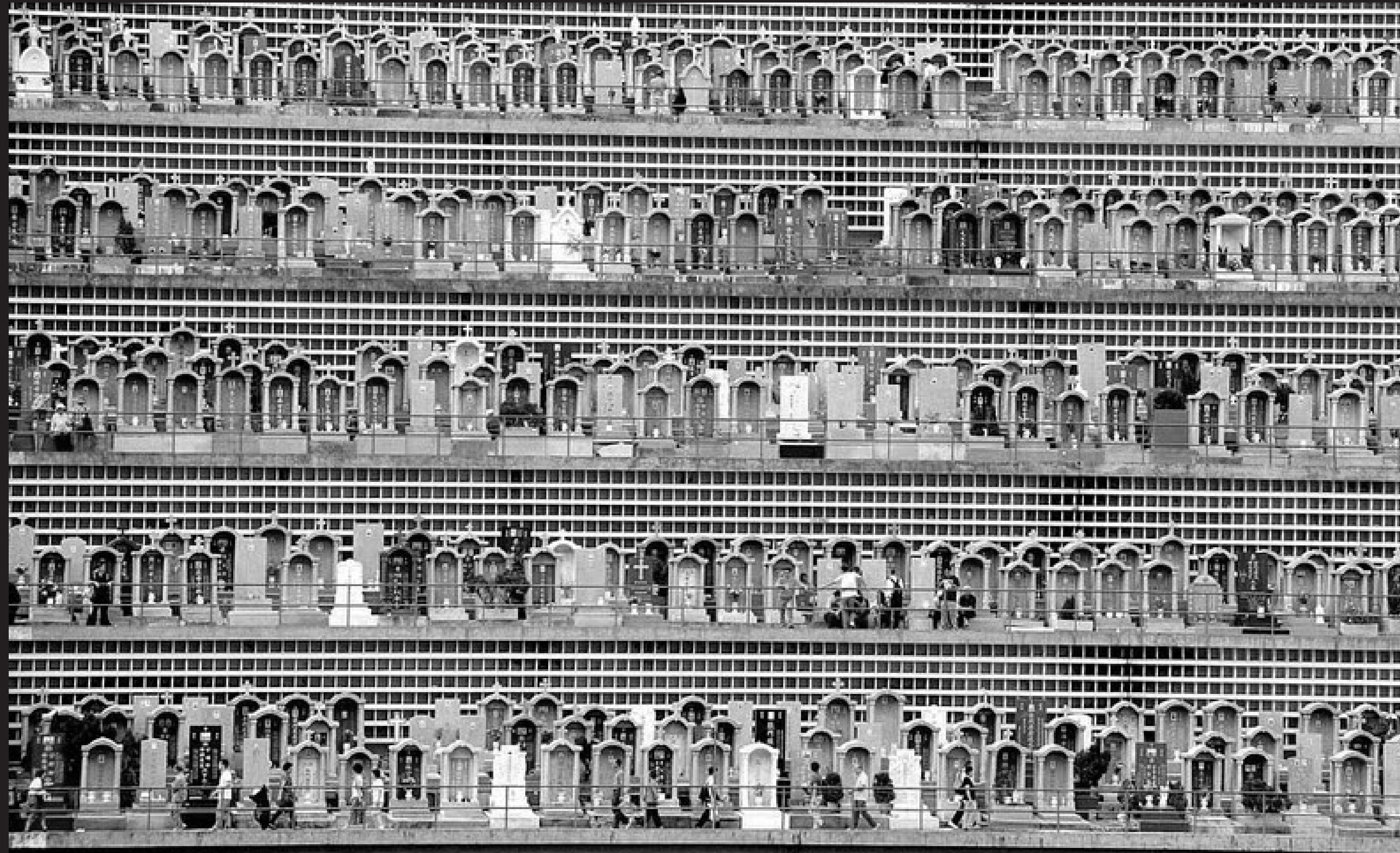





RELIGIOUS AFFILIATION  
IN HONG KONG

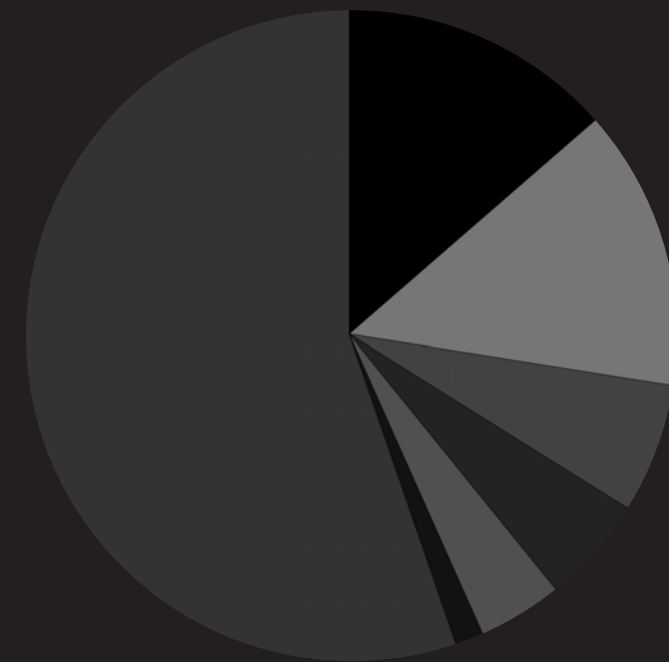

**55% No religion**

- 14% Buddhism
- 14% Taoism
- 7% Protestant
- 5% Catholics
- 4% Muslim
- 1% Hinduism

note: figure of 2014 by Government of HK

46,100 deaths in 2016, estimated 55,000 deaths in average in coming 20 years

in 2016 9% burial and 91% cremation

estimated 5% burial and 95% cremation,

meaning 52,000 cases of cremation in coming 20 years

6 crematoria

214,332 niches (9,115 vacant niches as at June 2015) in 8\*+140\*\* columbaria

4\*+23\*\* cemeteries for coffin burial (3 for indigenous villagers),

a total of 23,728\* coffin burial spaces (8,178 spaces vacant as at June 2015)

exhumation after 6 years and re-burial or cremated

217,411\* urn burial spaces (38,052 spaces vacant as at June 2015)

3 designated waters for sea scattering

11\*+2\*\* gardens of remembrance for scattering of cremated ashes

note: \*public \*\*private



AIRPORT

METROPOLITAN AREA

● SITE

● TSIM SHA TSUI

● CENTRAL

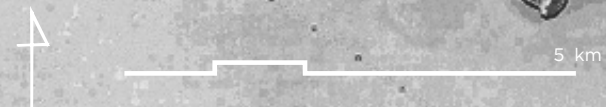

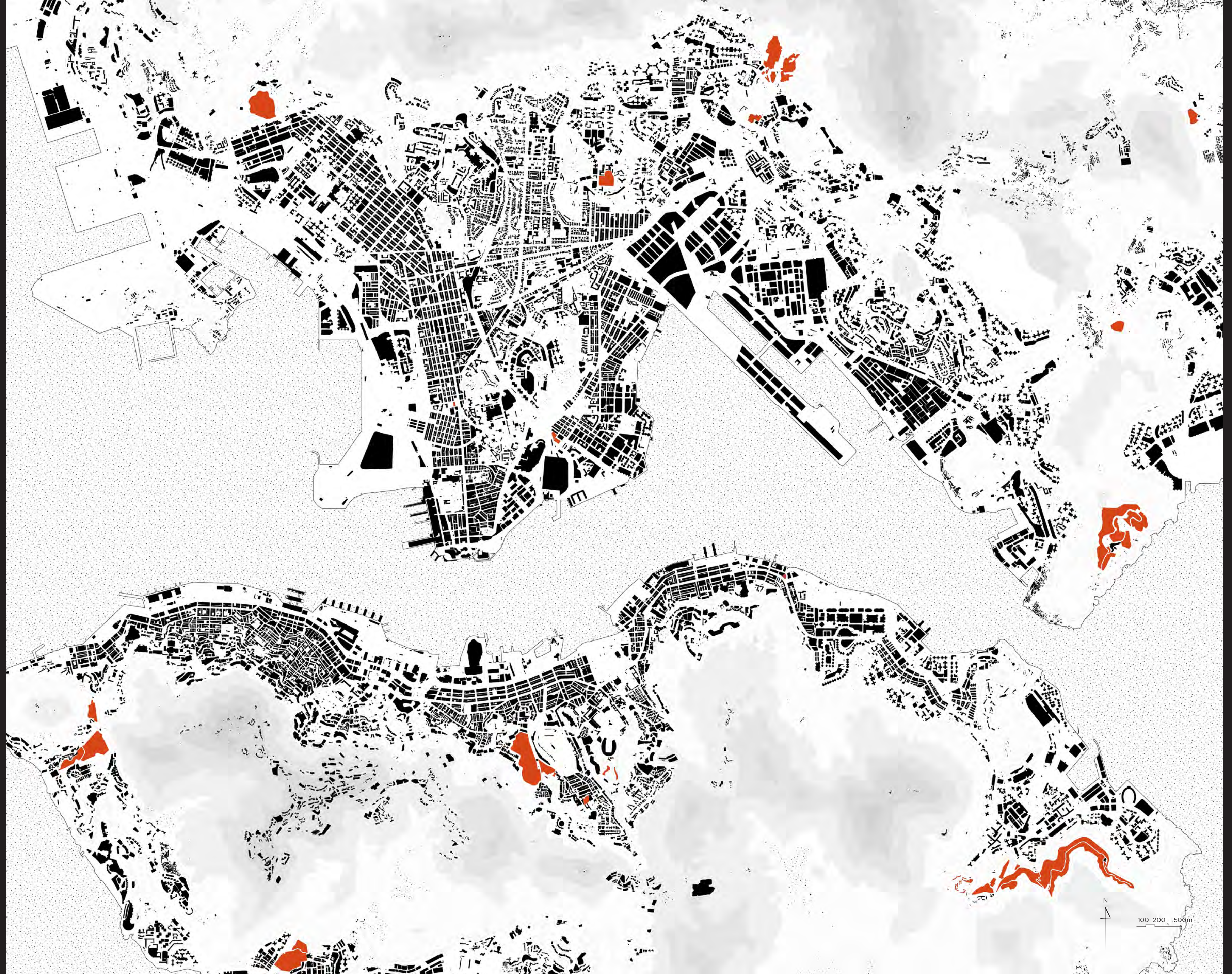
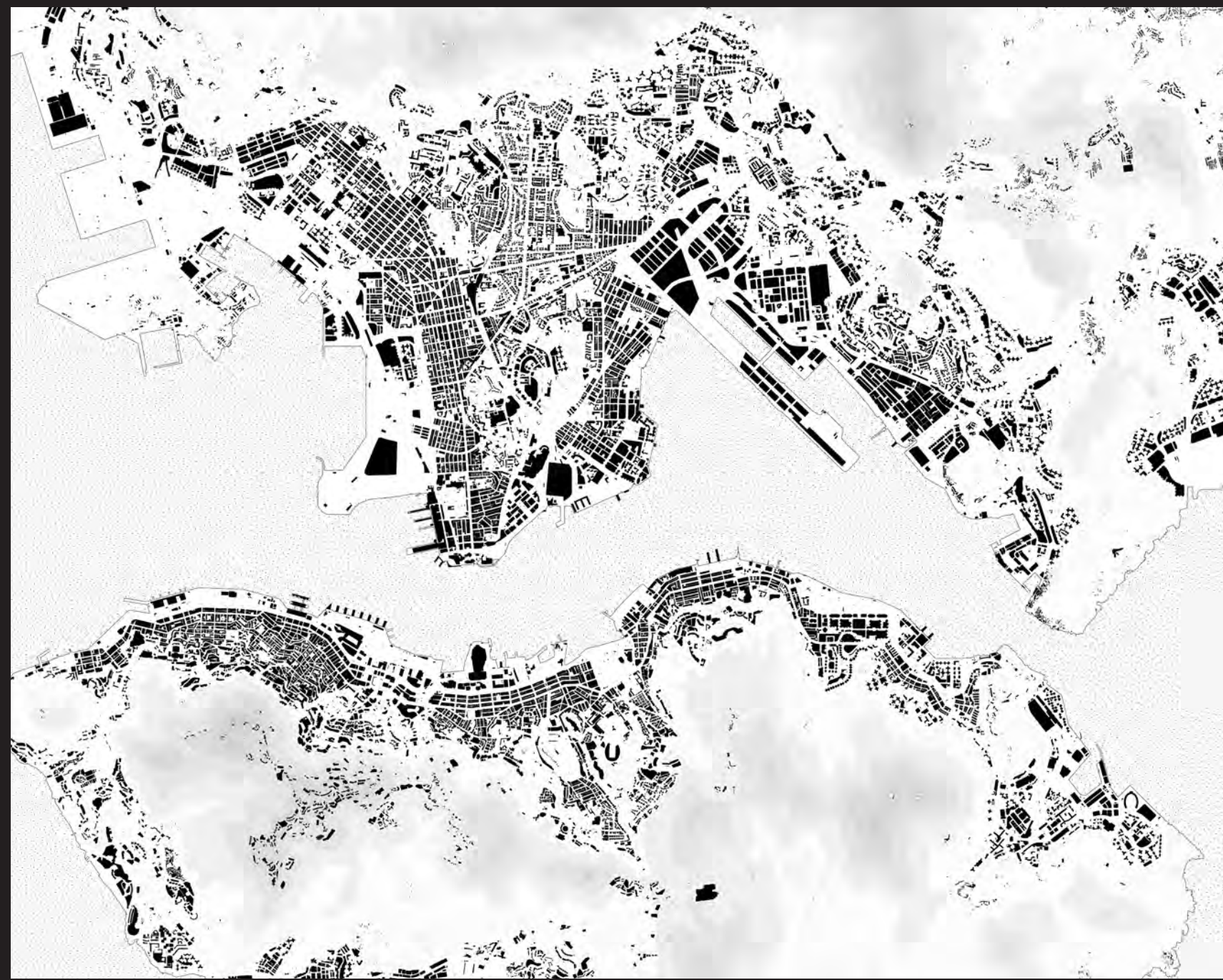

Hong Kong  
7,346,700



1,105.7km<sup>2</sup>

Oslo  
658,390



480km<sup>2</sup>

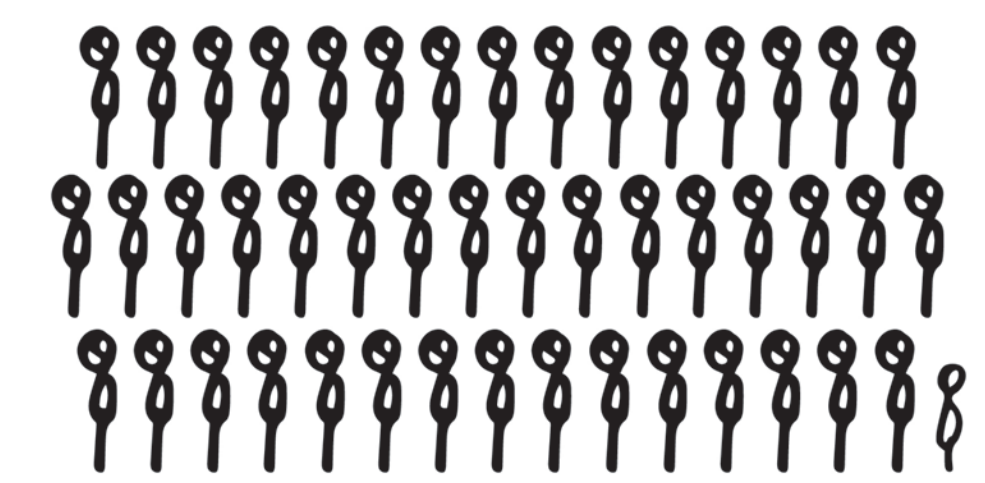

46100  
deaths per year



126  
deaths per day



5  
deaths per hour

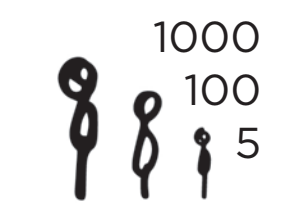

6,644 / km<sup>2</sup>

4.75 times



1,400 / km<sup>2</sup>

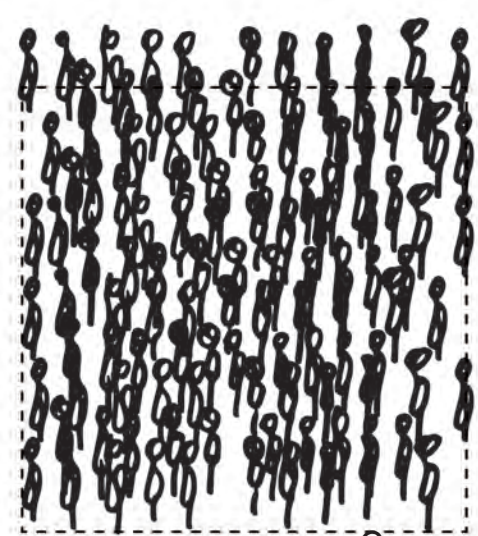

57,360 / km<sup>2</sup>

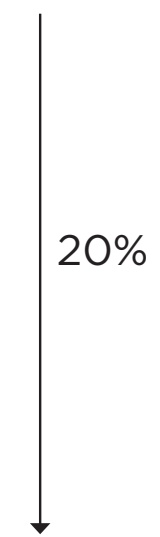

9220  
of the bereaved still suffer  
from depression 1.5 years  
after the death of the  
loved ones

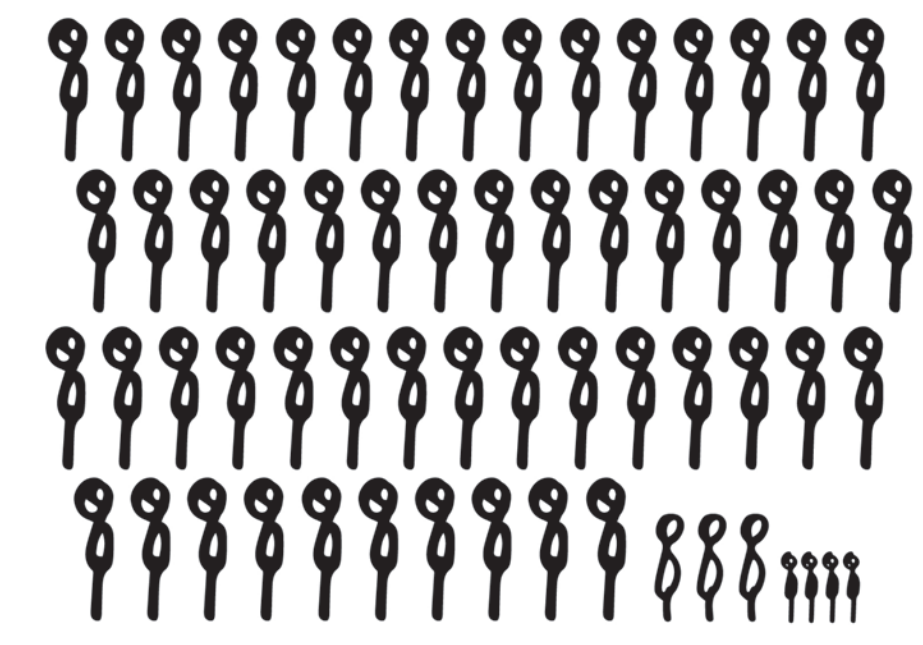
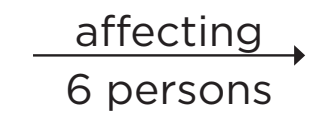

55320  
persons suffer from  
depression

birth

60800  
8.3%

death

46100  
6.4%

(Norway)

59000  
11.4%

40700  
7.9%





**Design Concept**

THE CEMETERY-PARK CONCEPT

URBAN AREA

FREQUENT VISITS

CONTEXT AND PROBLEMATICS

**DESIGN CONCEPT**

**SITE SELECTION**

DESIGN STRATEGIES

THE DESIGN & PROCESS

PROJECT VISION

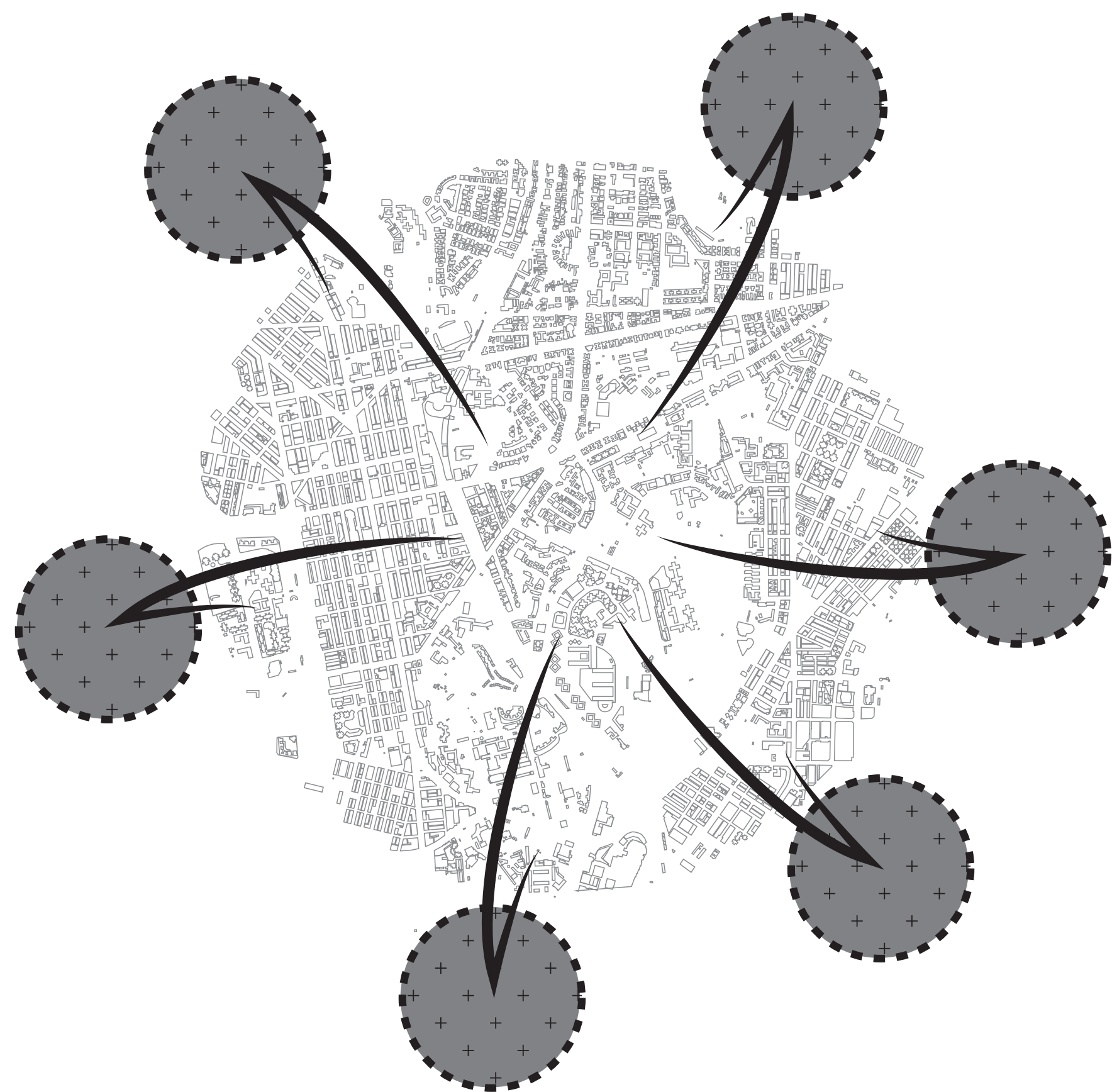
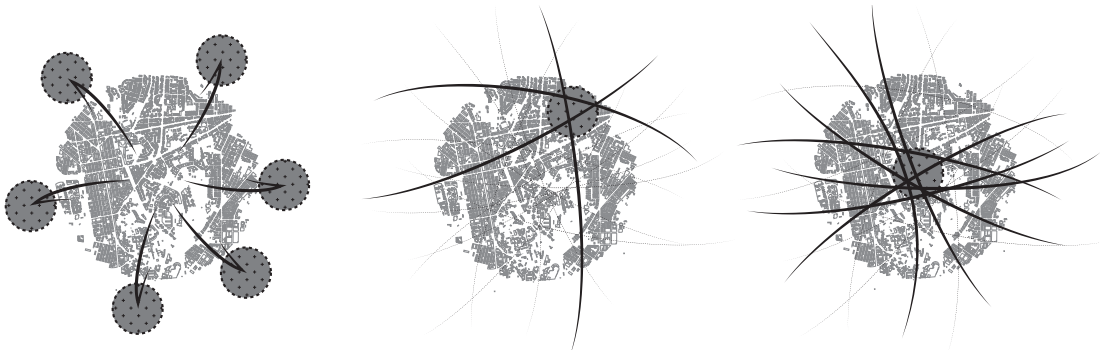



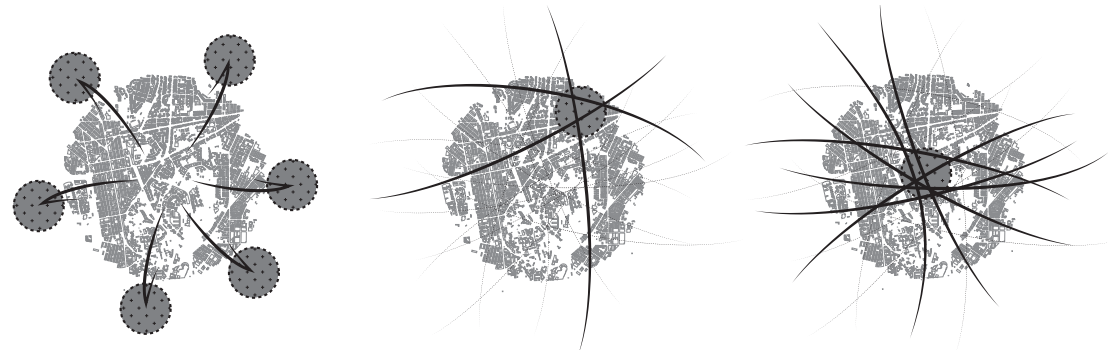

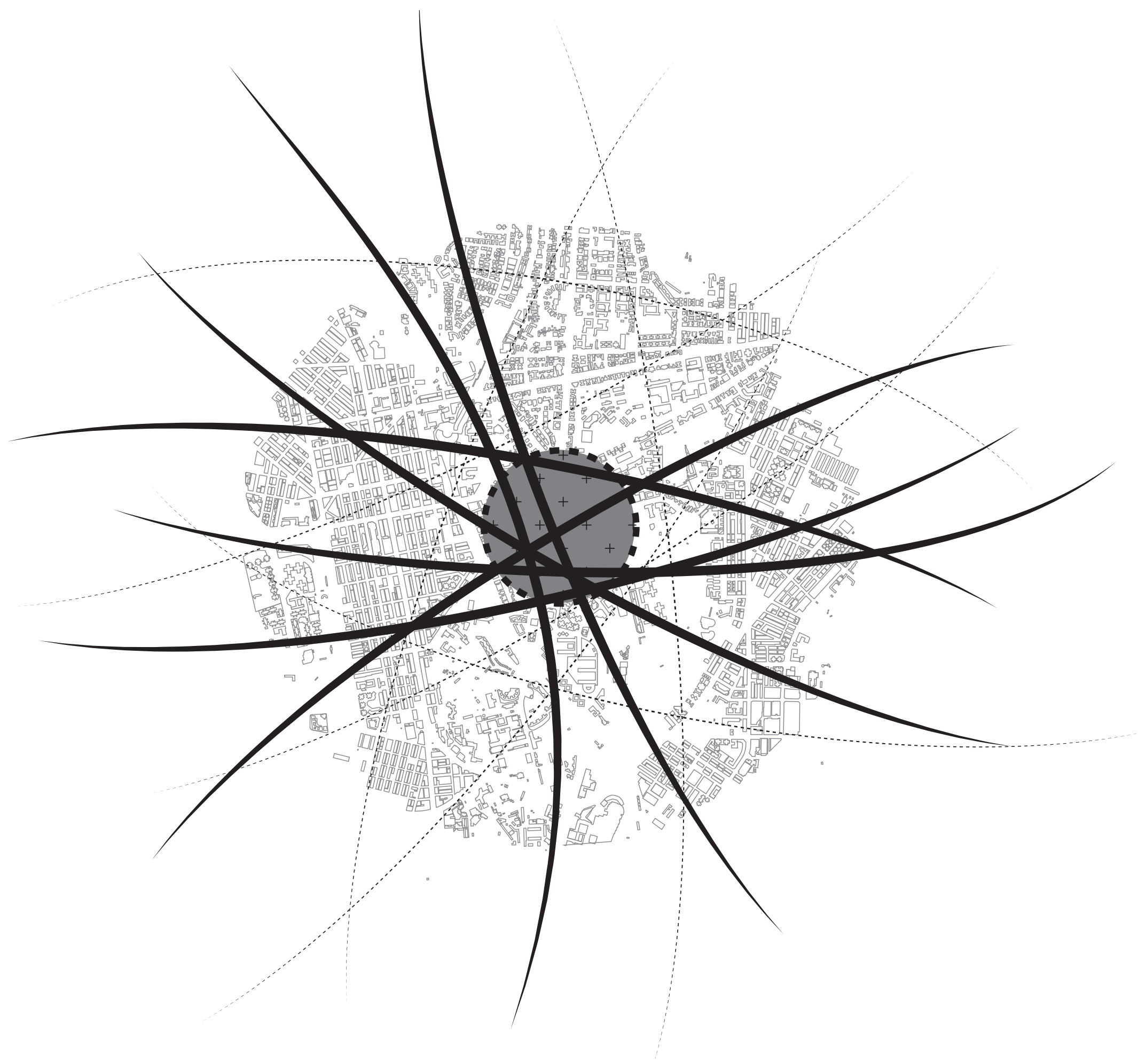
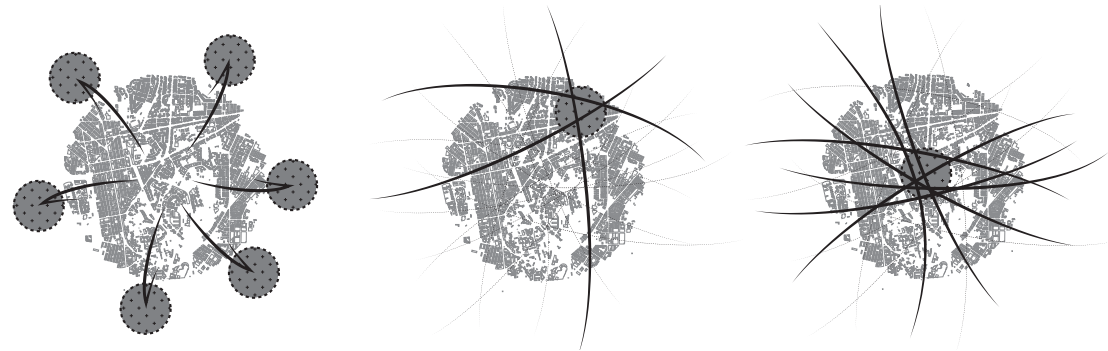



**KAI TAK**

**Kai Tak**

**a rare supply of land  
in metropolitan area  
of Hong Kong**

site selection  
for the first  
"cemetery-park"  
in urban area!

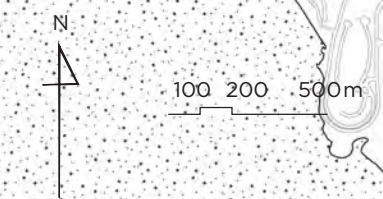

















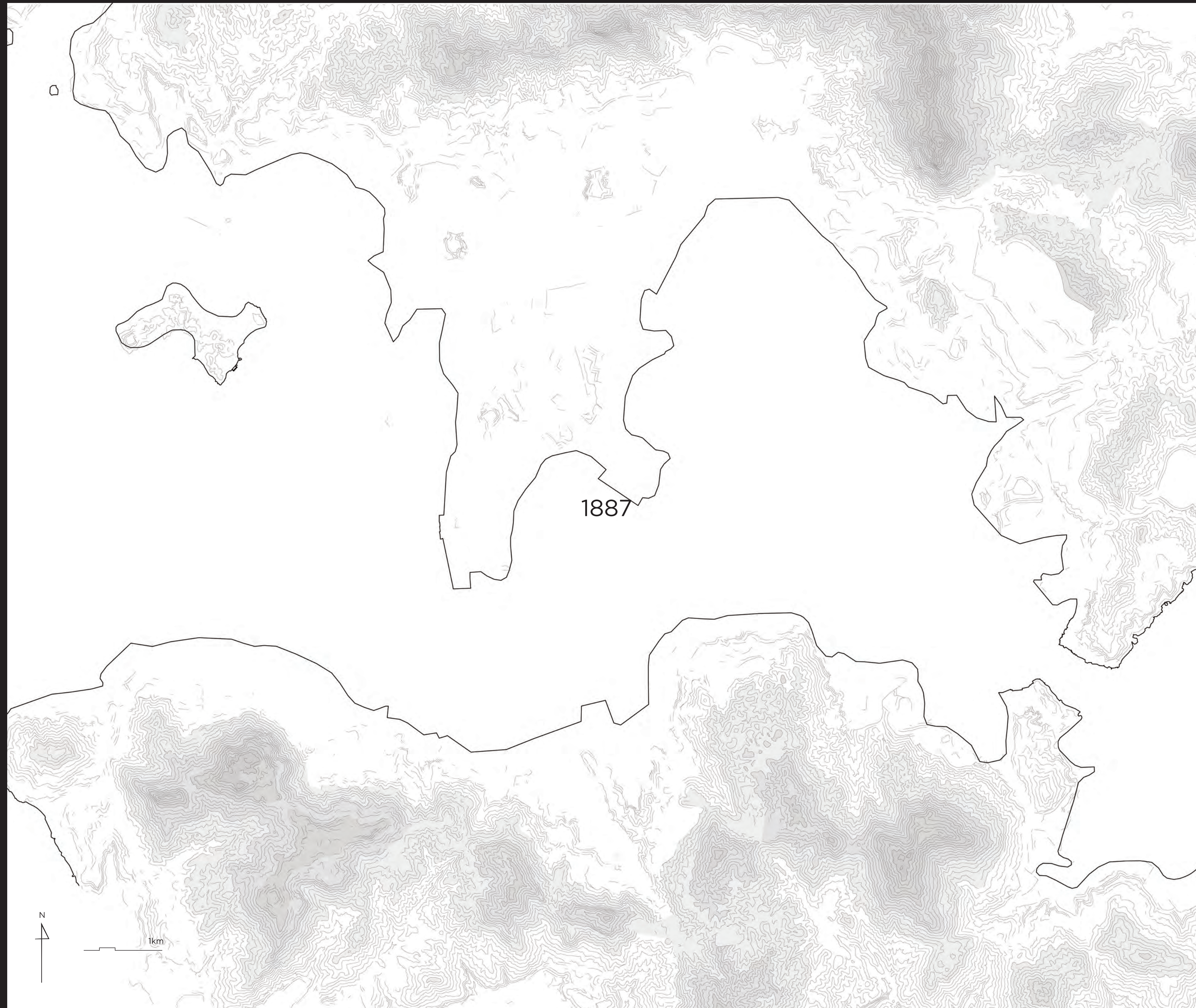

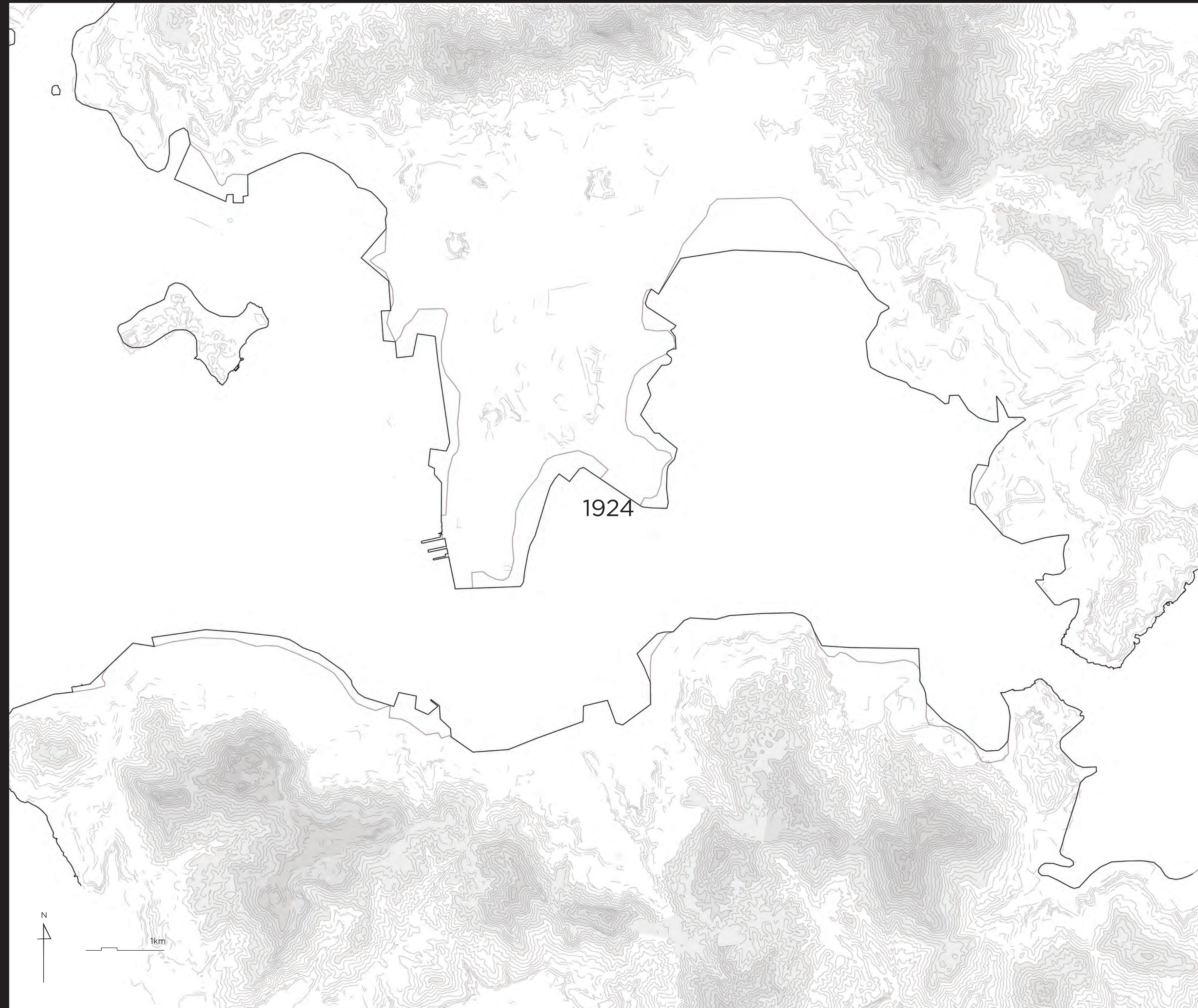

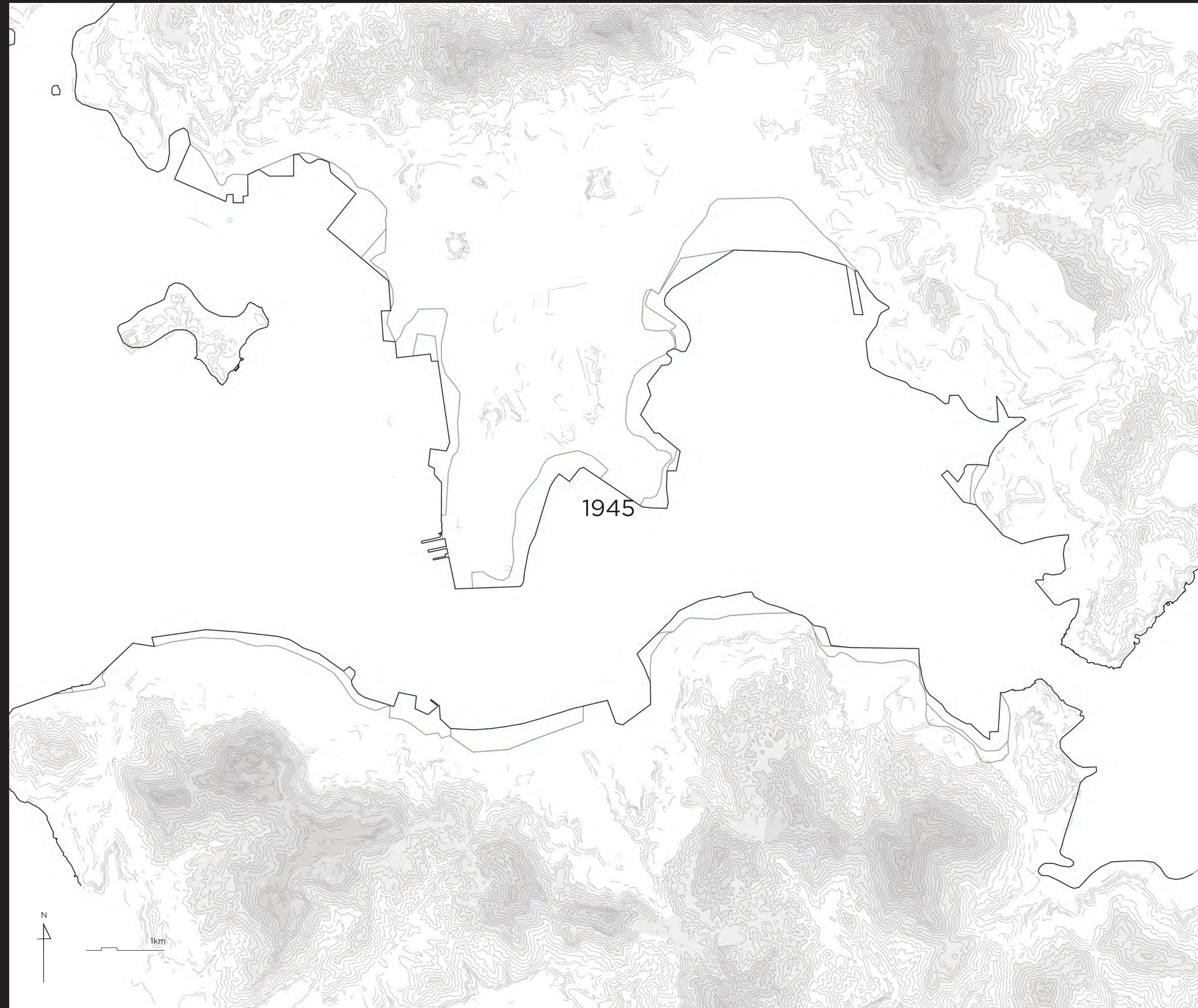

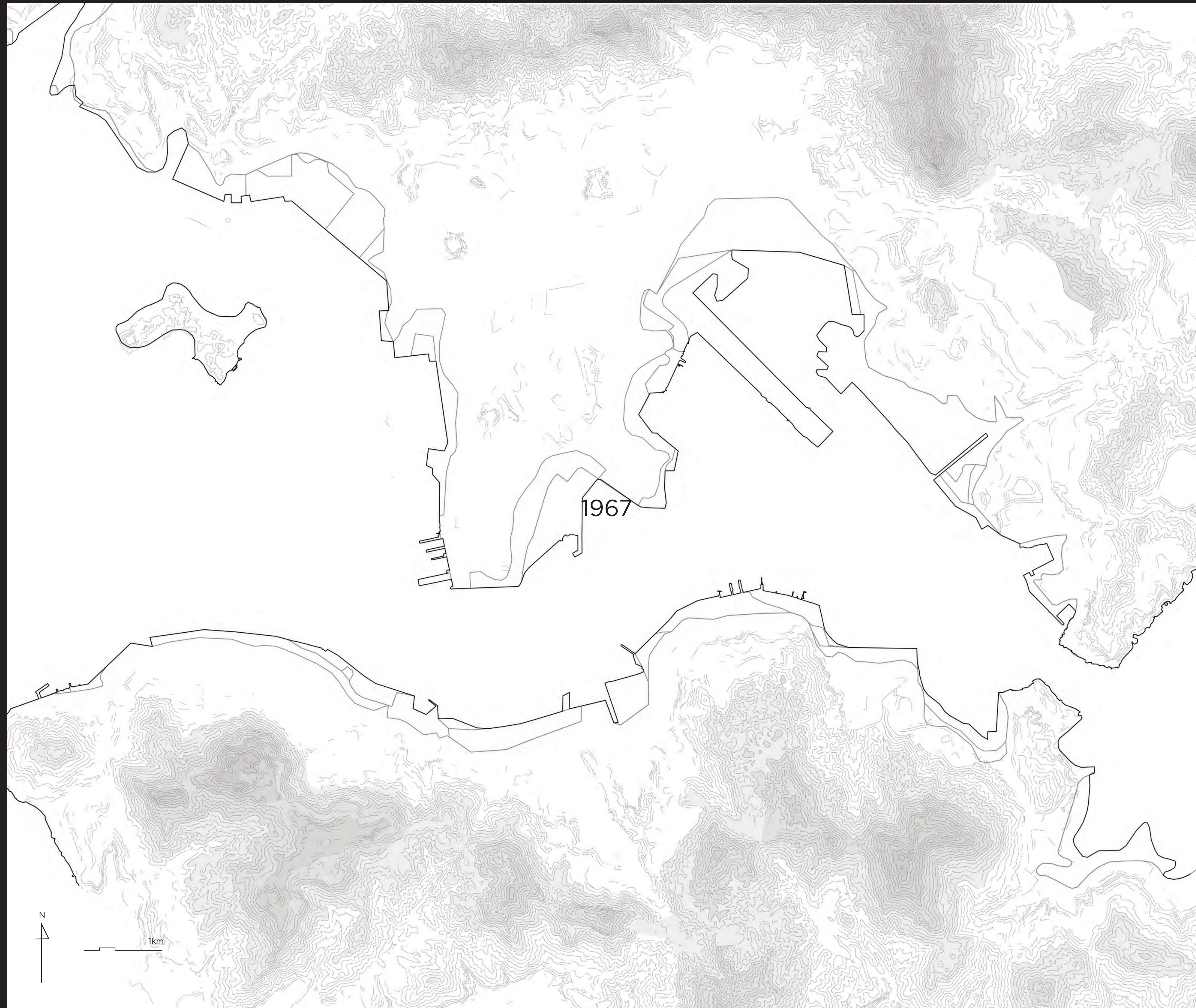

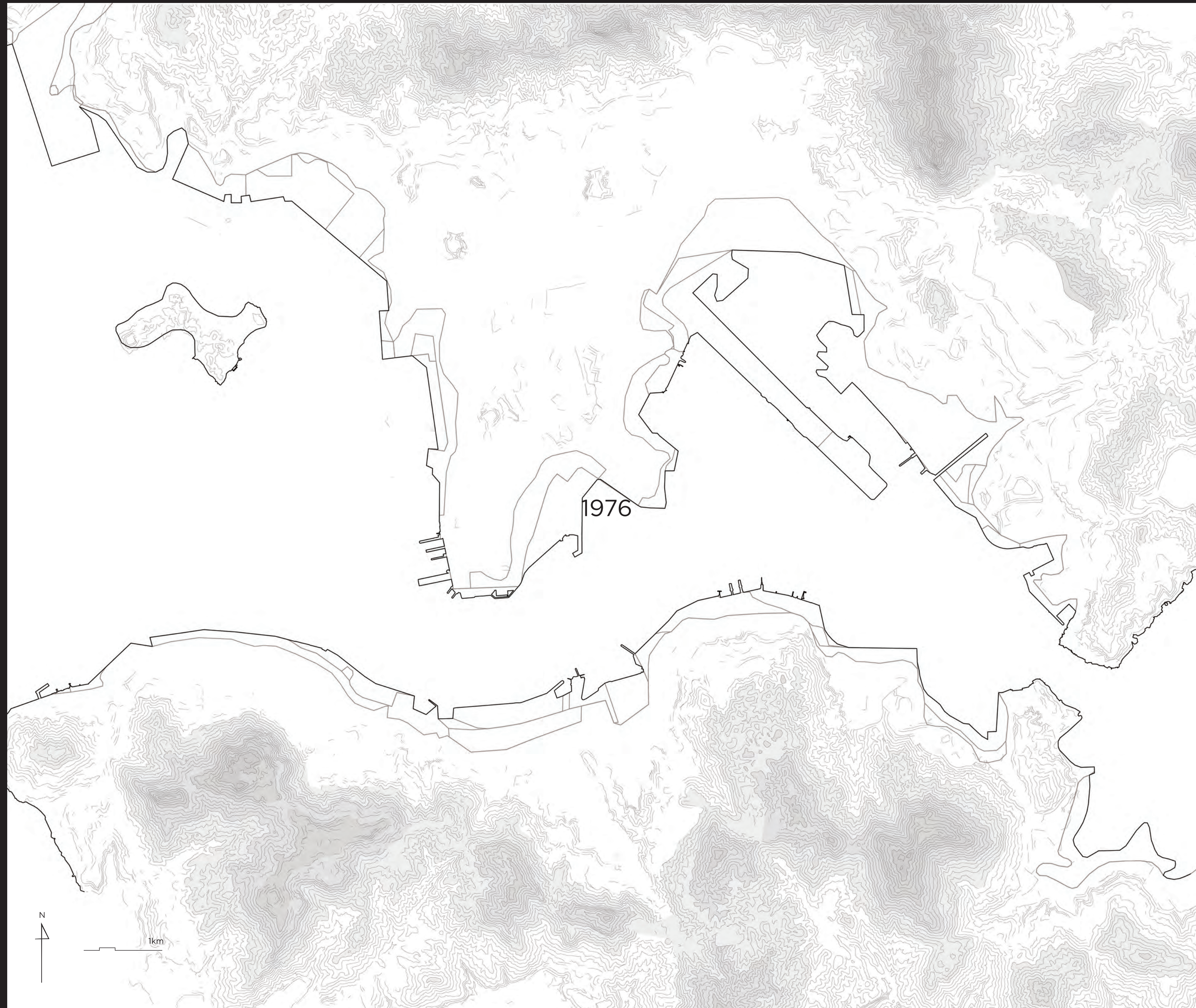













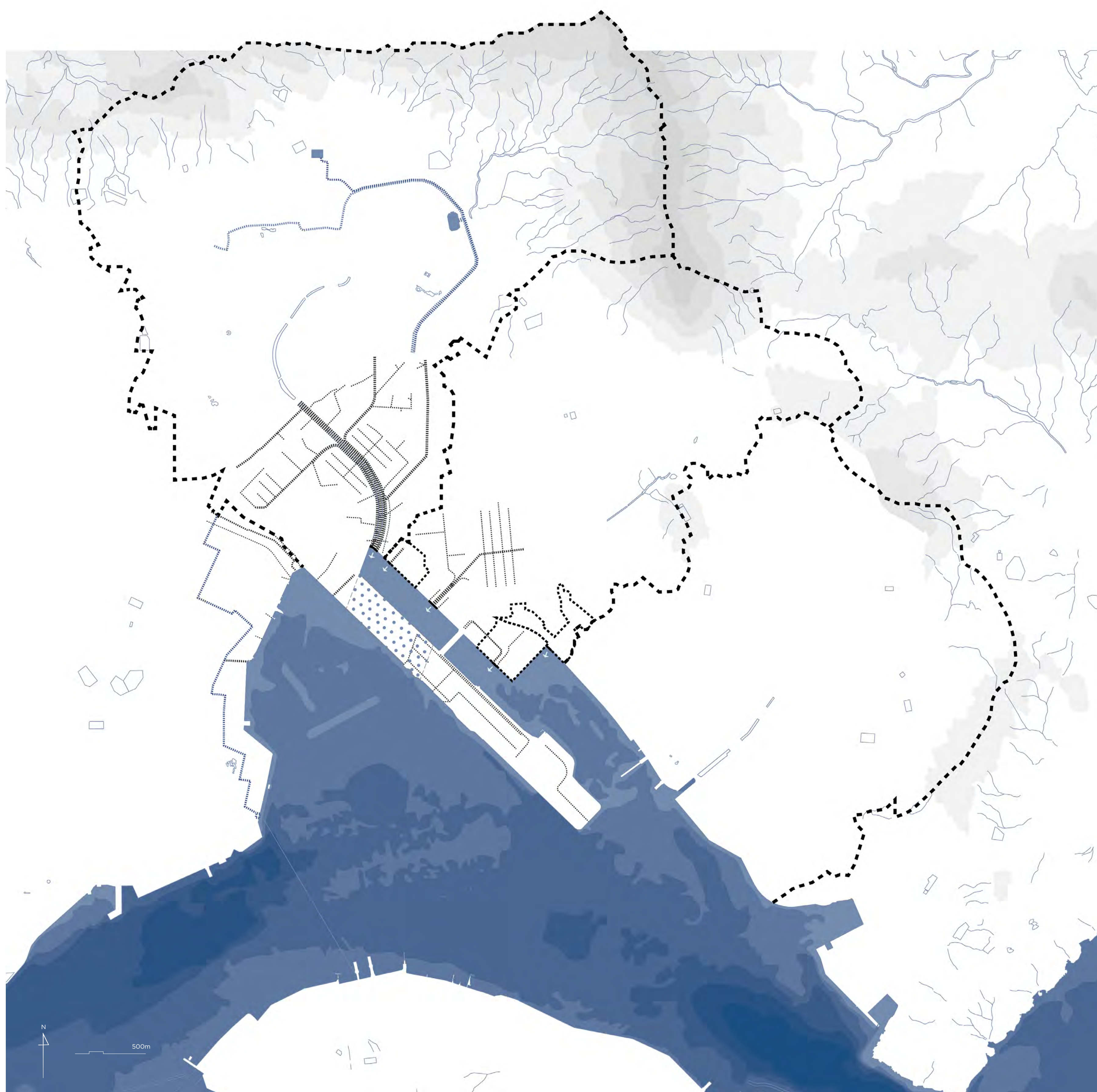









-  surface water
-  major salt water supply
-  major fresh water supply
-  watershed
-  sub-watershed
-  stormwater drains
-  underground channel to improve water quality
-  water depth in every 5m



walking distance  
from residential  
(in diameter)

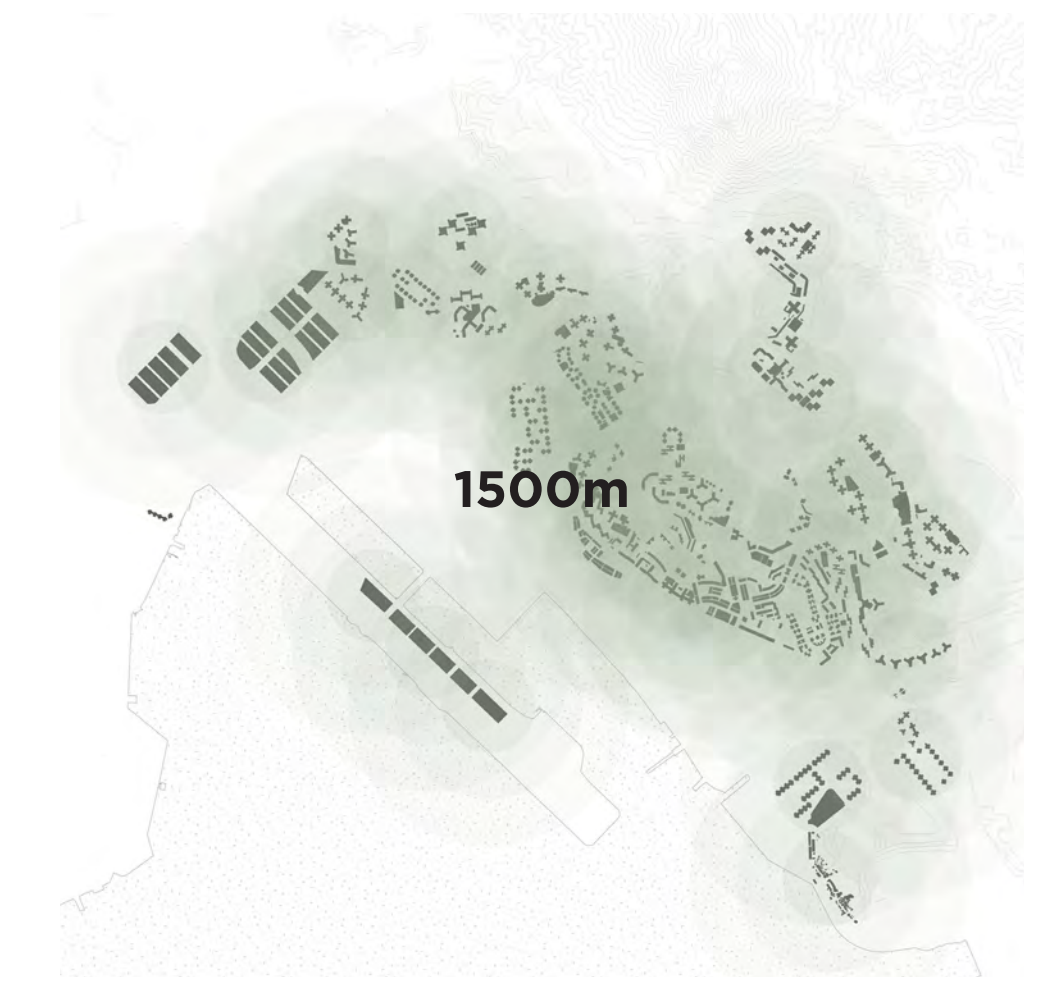
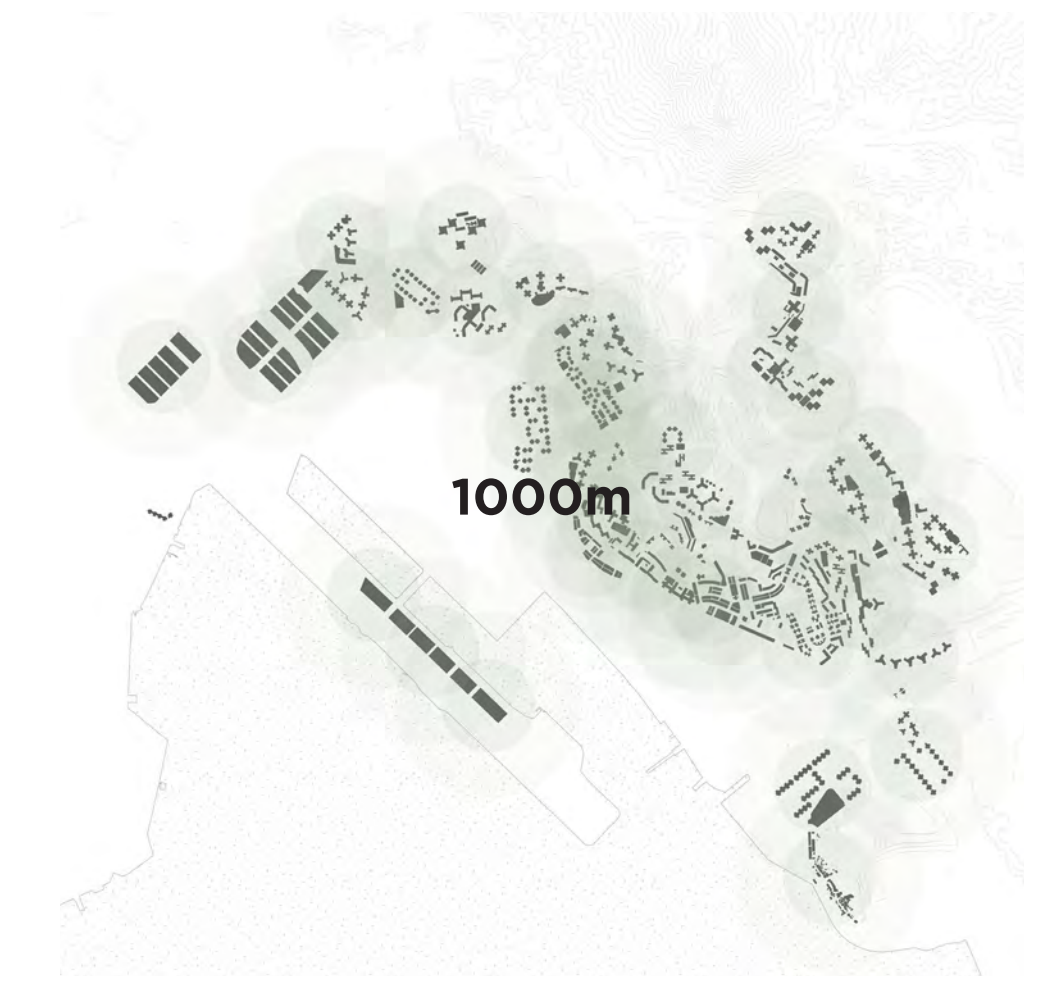

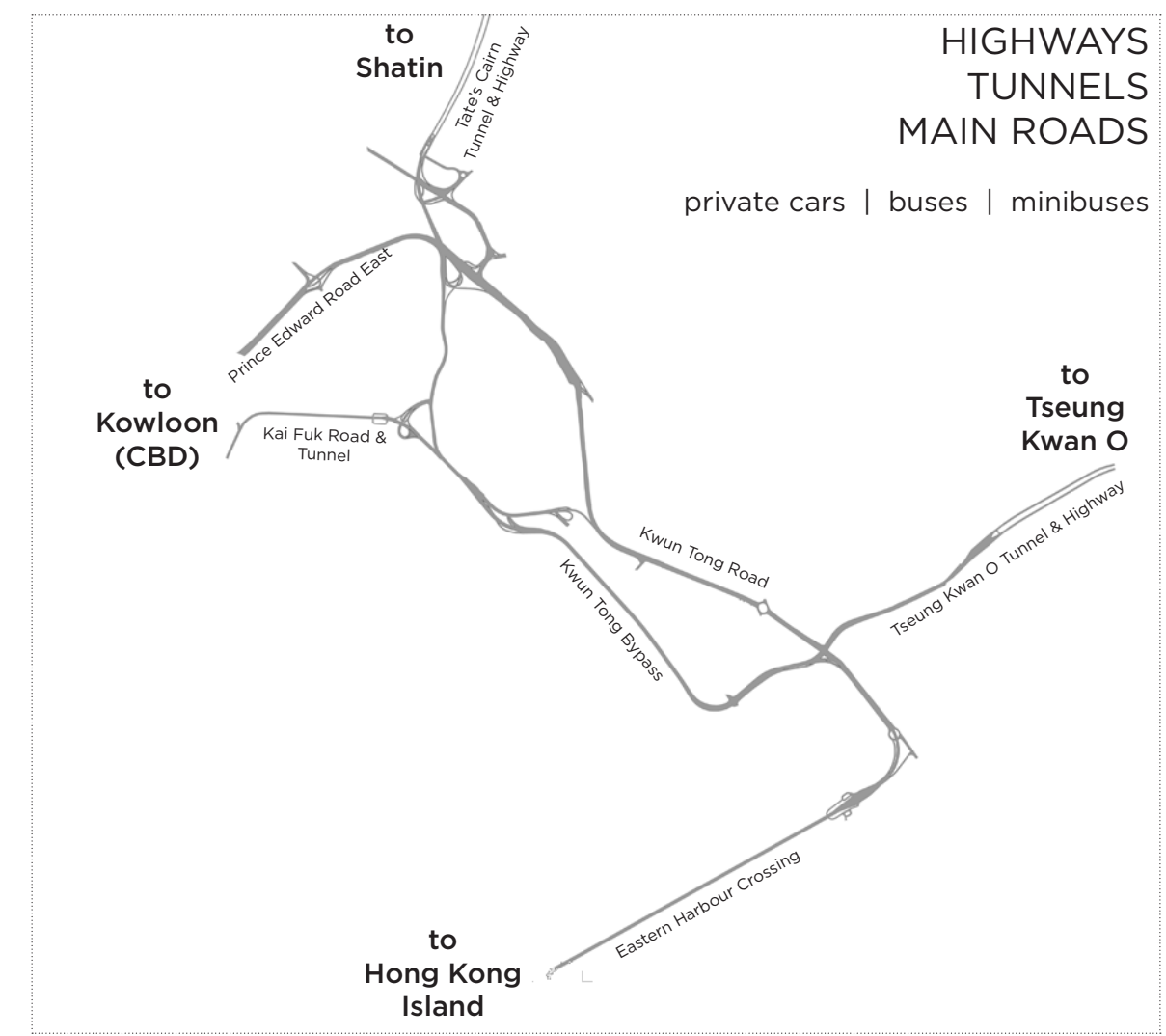
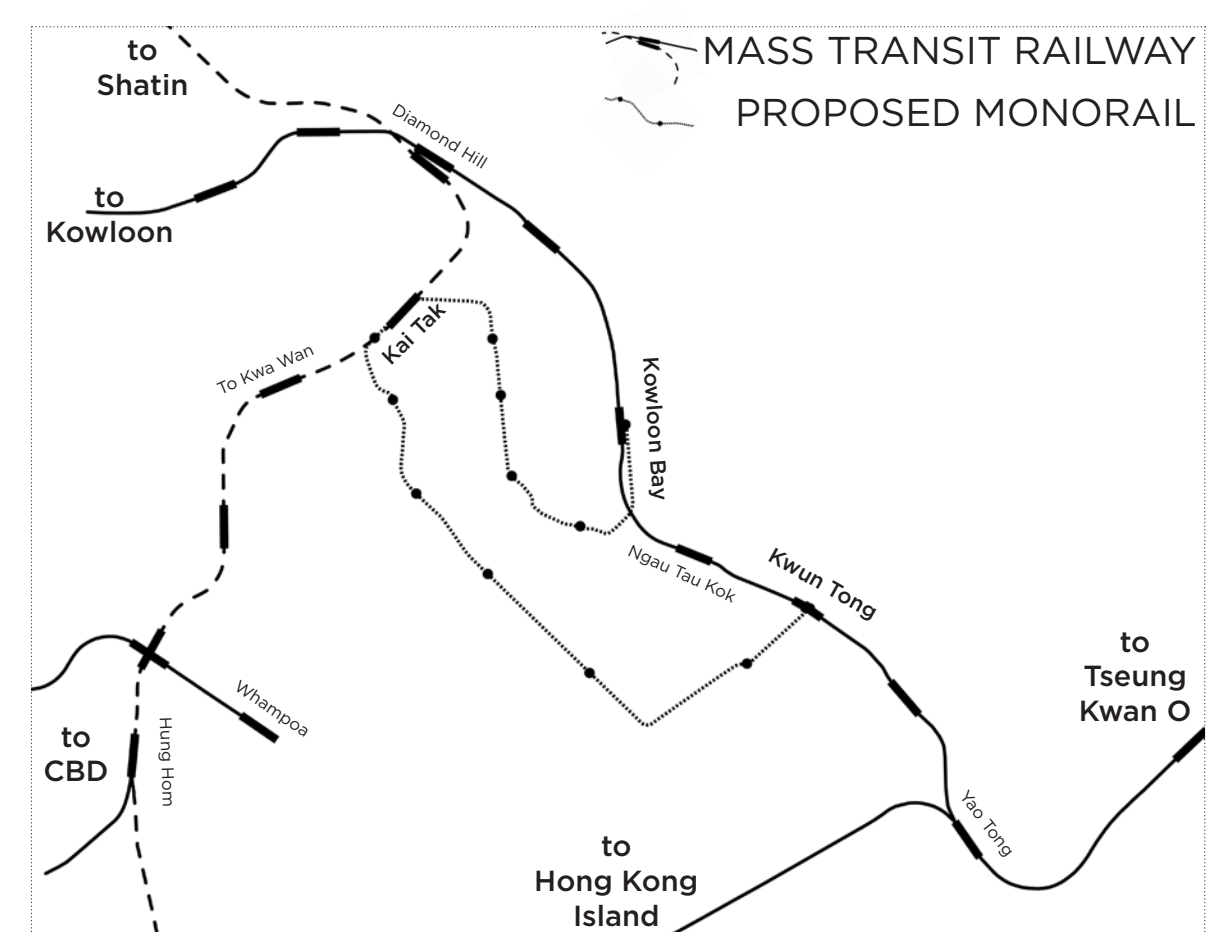
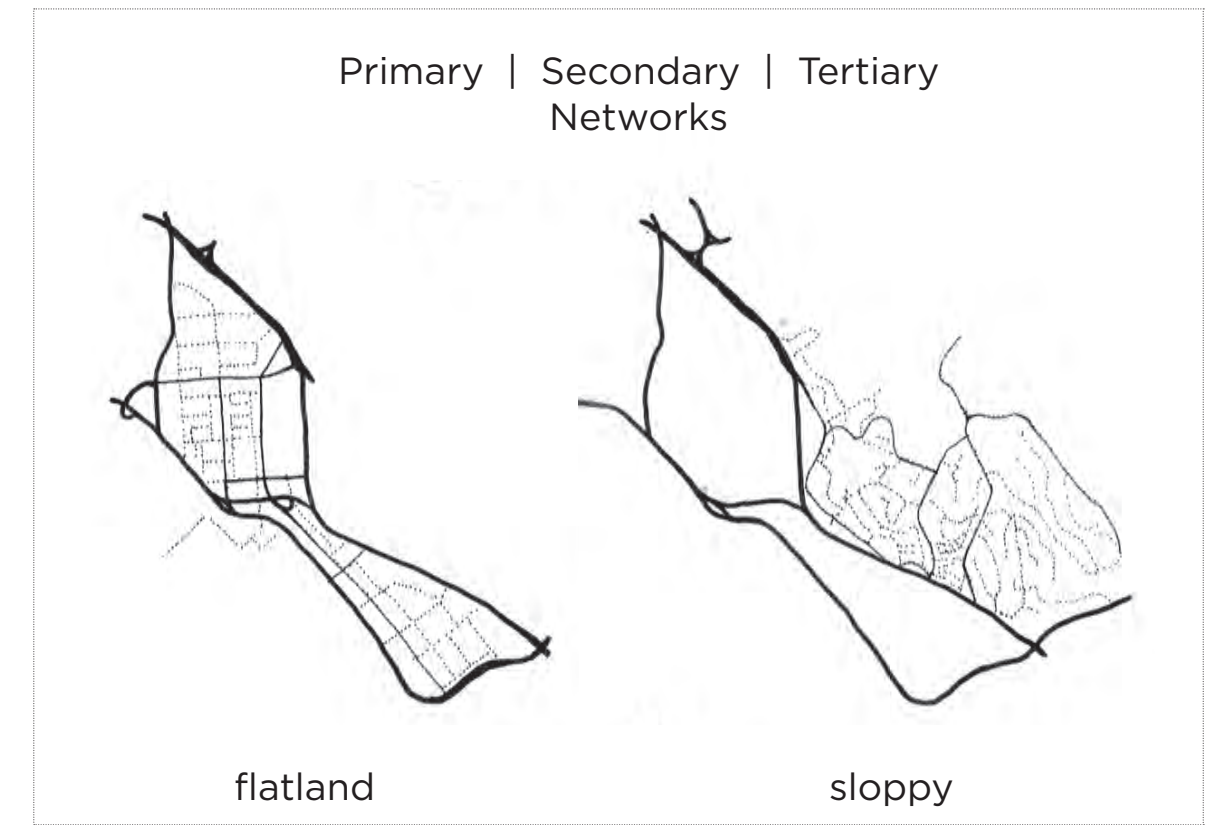
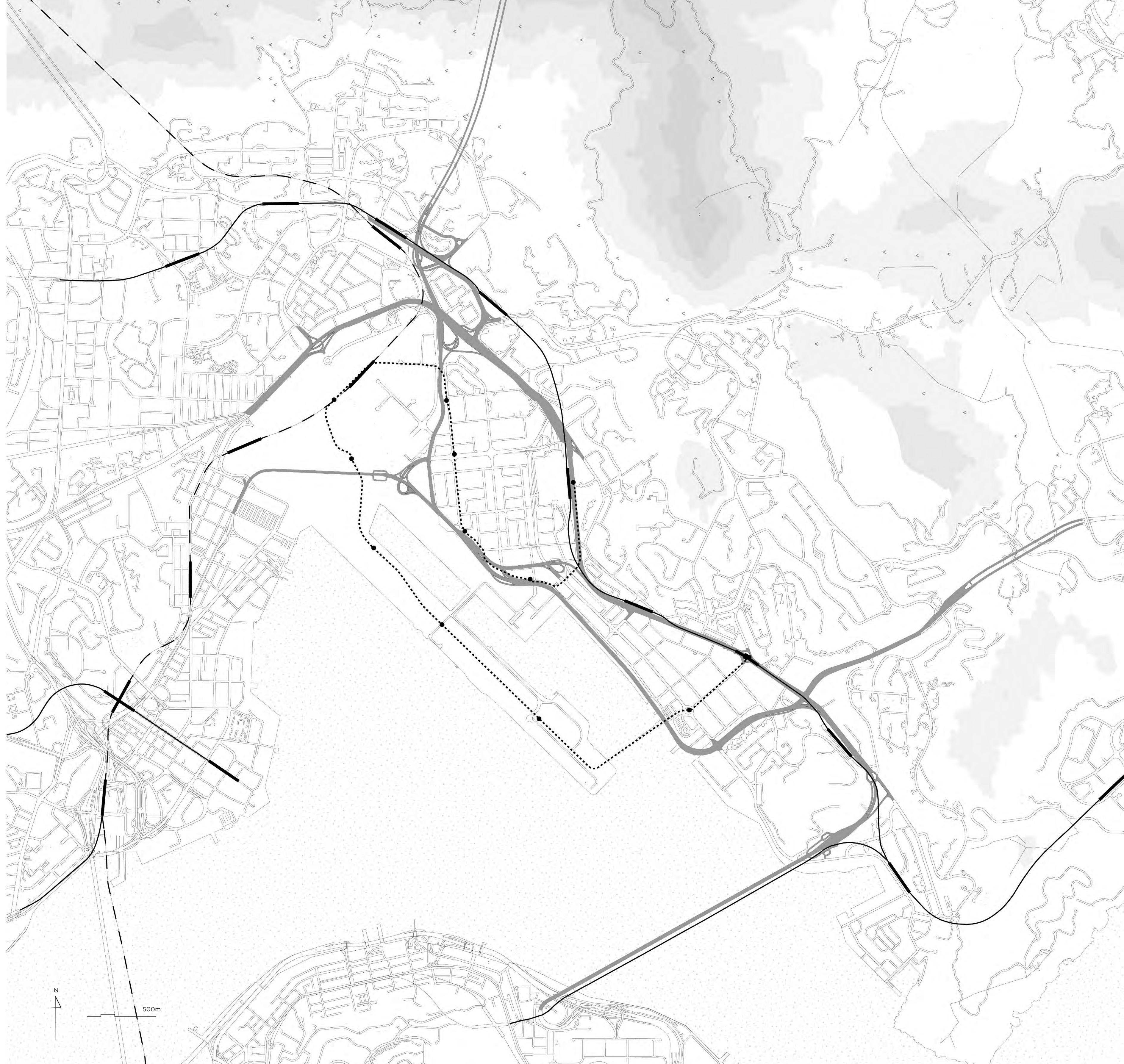

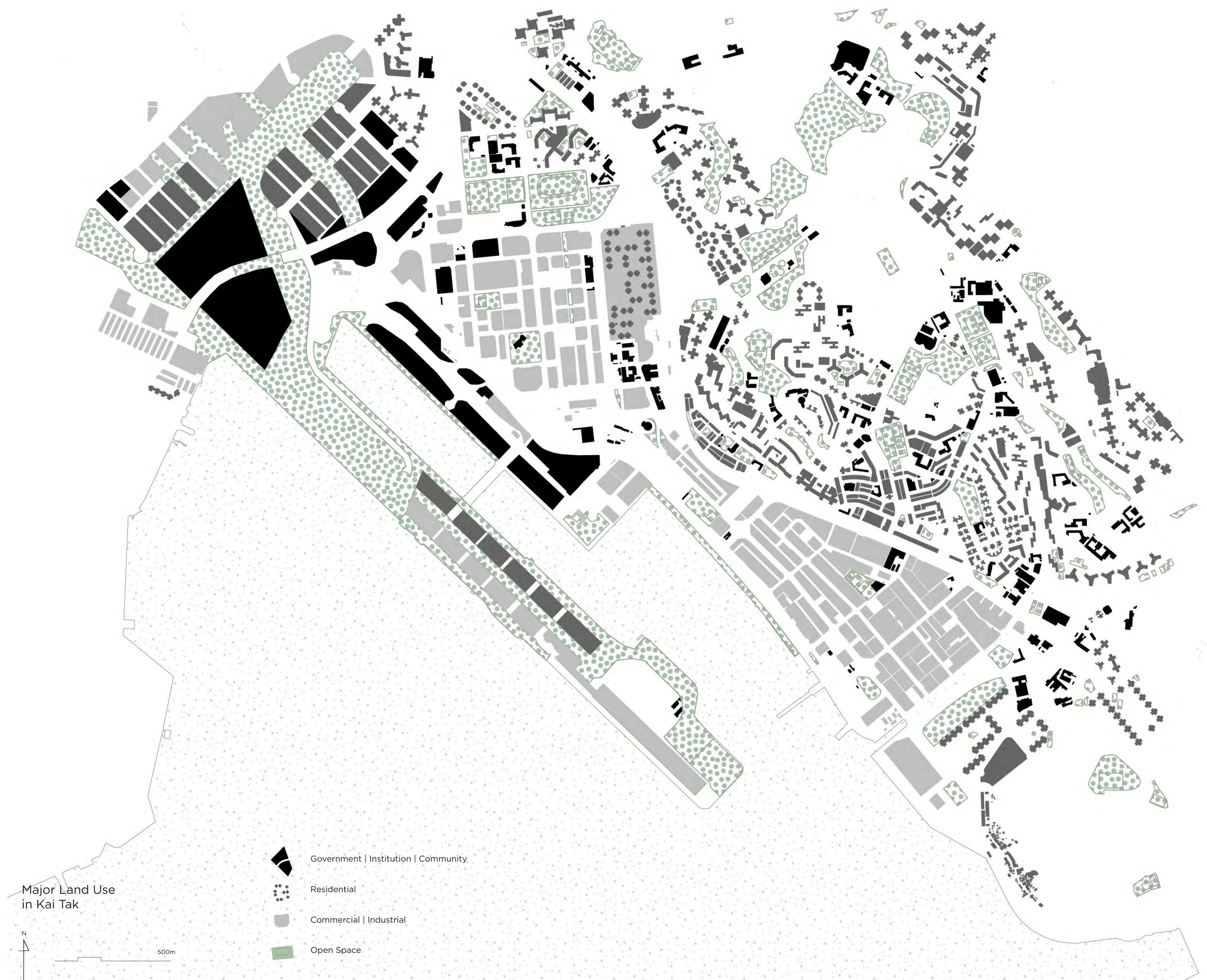



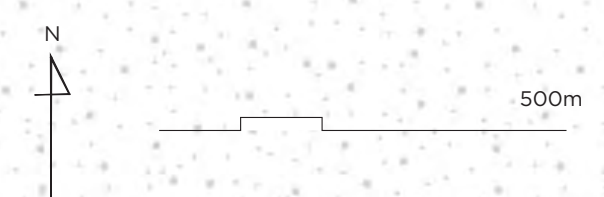



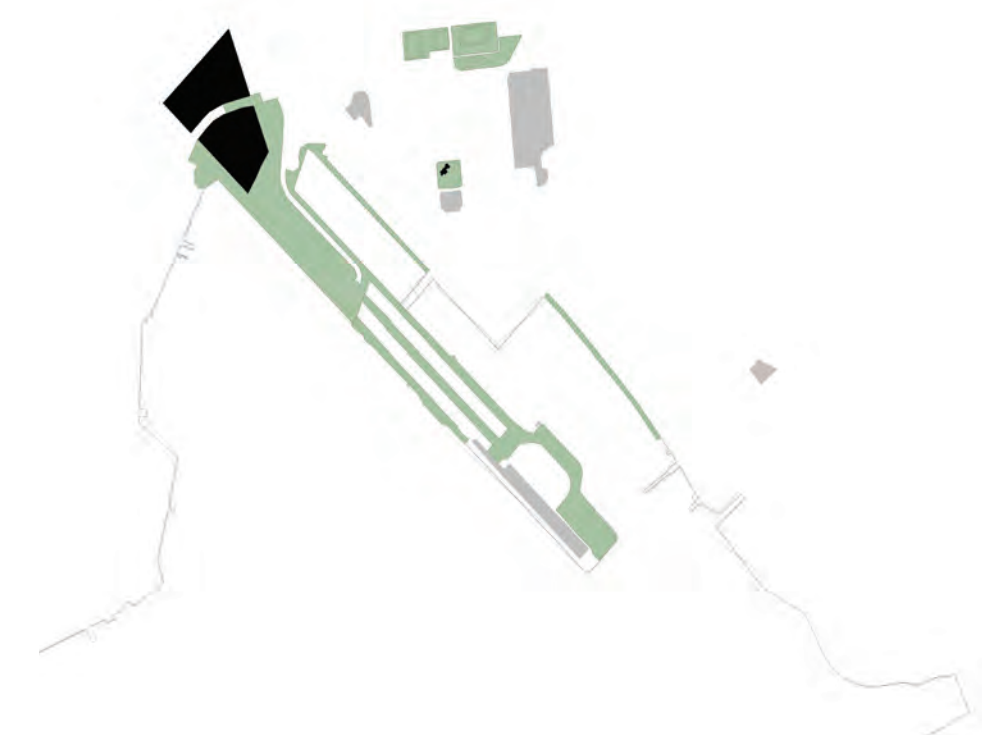

Major Land Use in Kai Tak

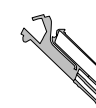

-  Government | Institution | Community
-  Residential
-  Commercial | Industrial
-  Open Space

LANDMARKS | ATTRACTIONS



- Government | Institution | Community
-  proposed sports complex
-  ZCB zero carbon building
- Open Space
-  proposed Metro Park
-  Kwun Tong Promenade
- Commercial
-  Kai Tak Cruise Terminal
-  Kowloon Bay International Trade & Exhibition Centre
-  Telford shopping centre
-  apm (shopping centre)
-  Megabox (shopping centre)



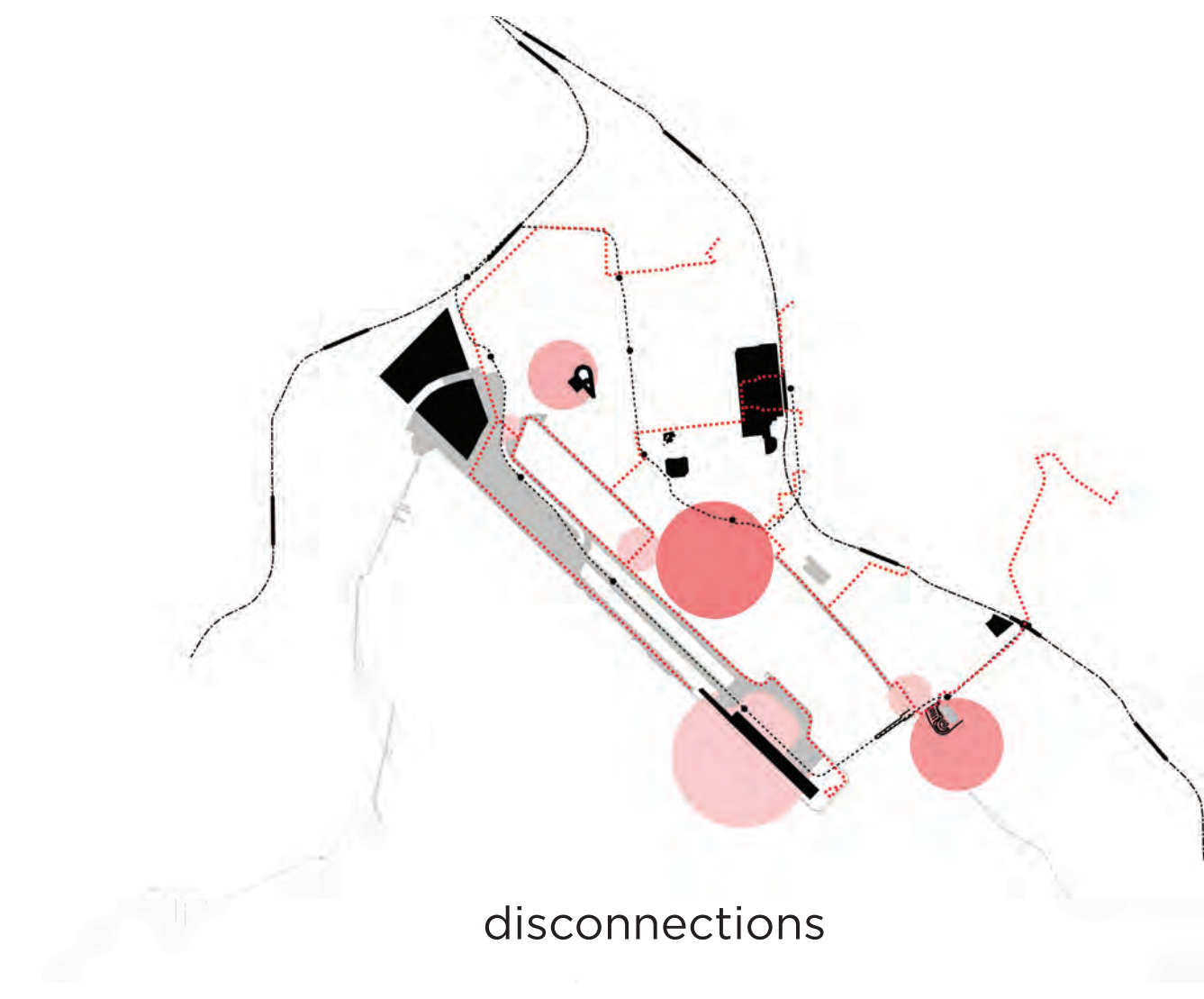
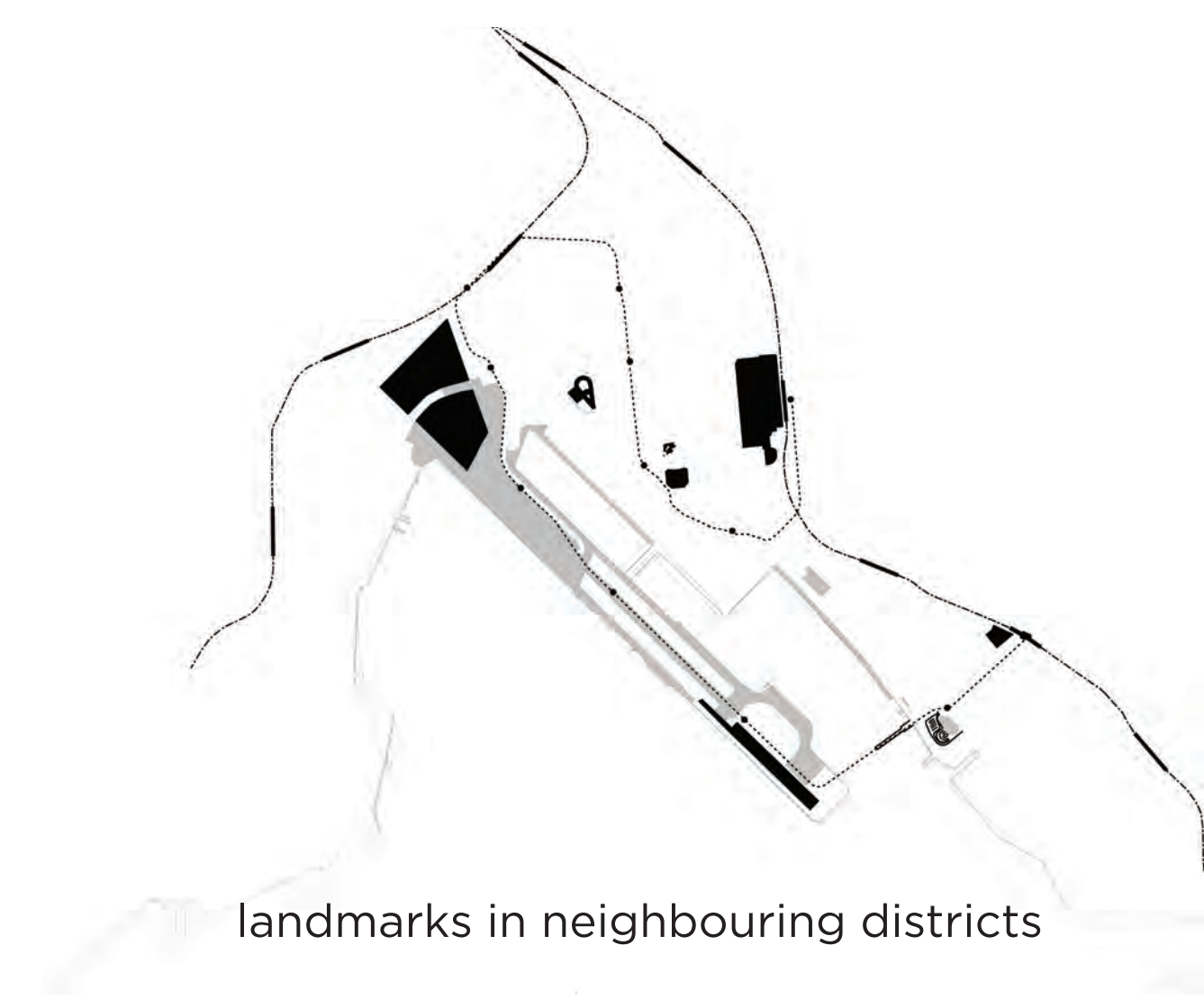
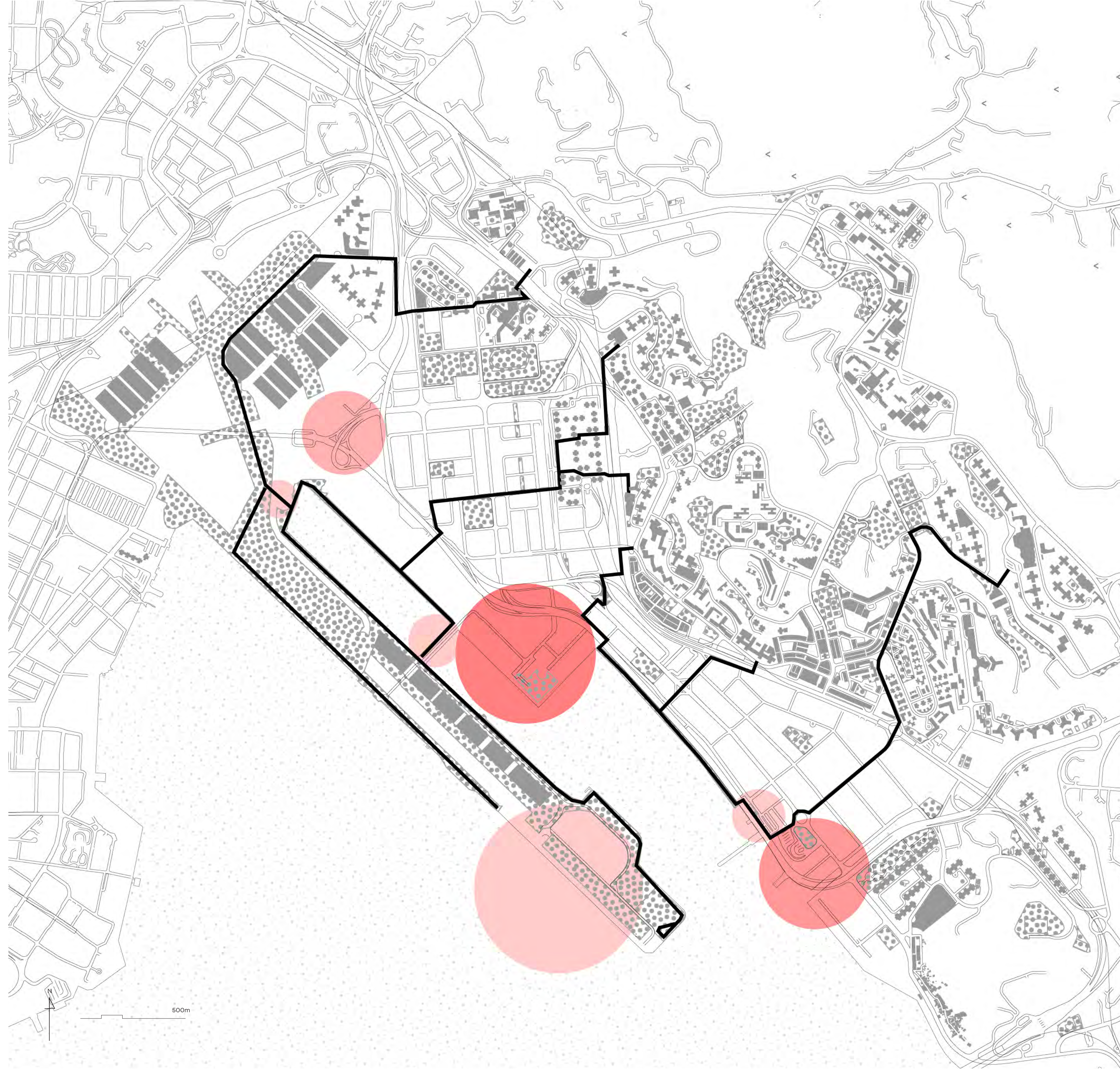

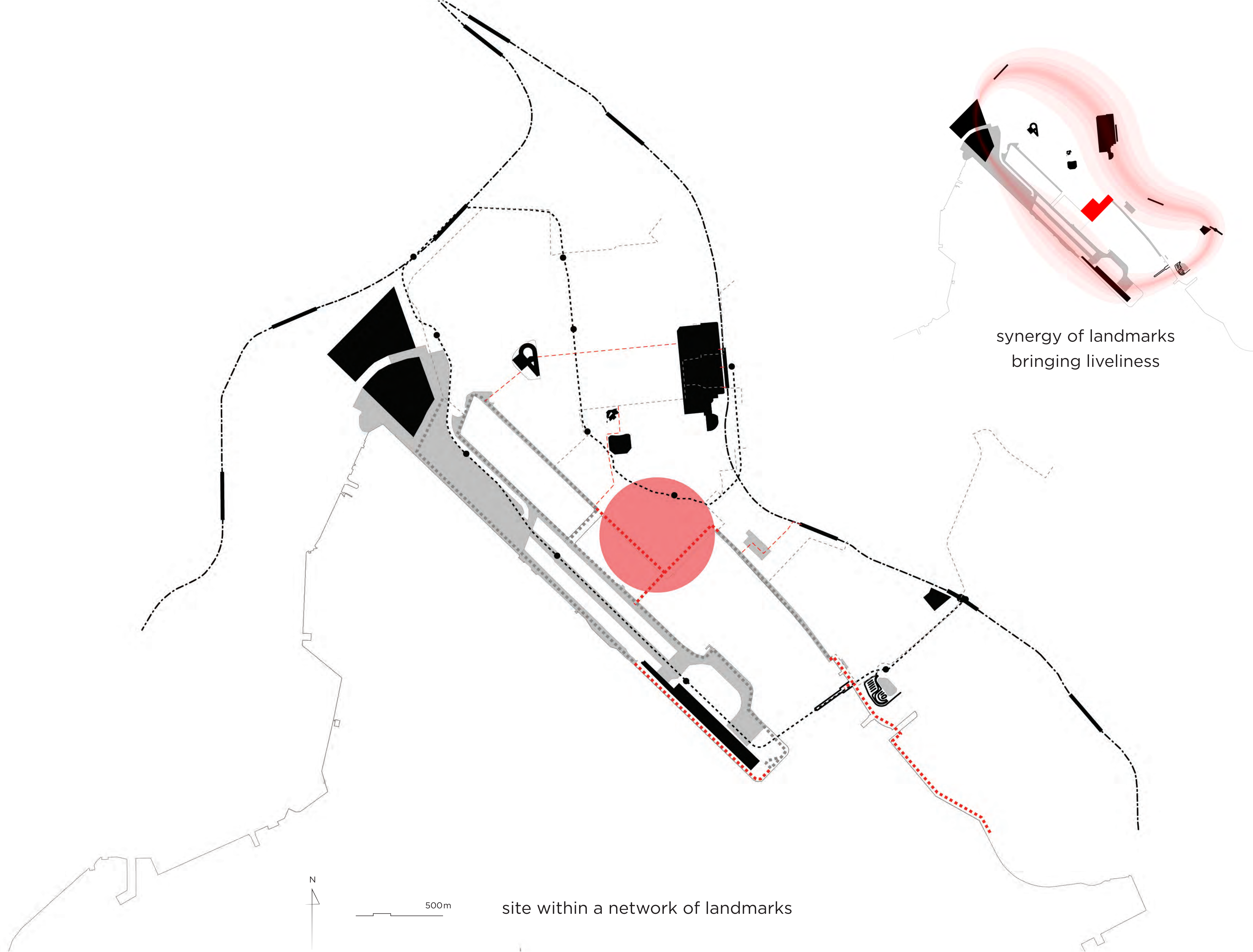

site within a network of landmarks

synergy of landmarks  
bringing liveliness

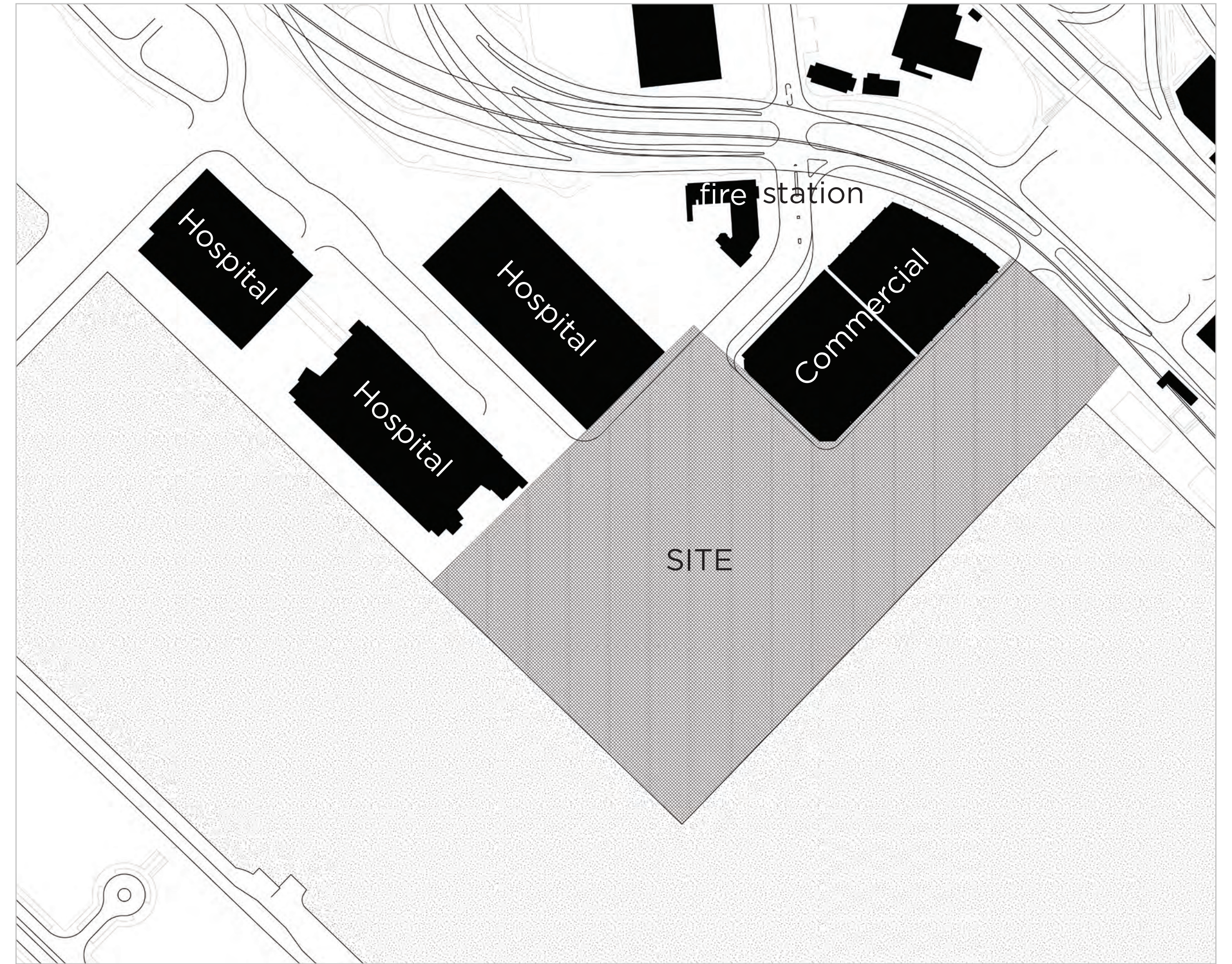

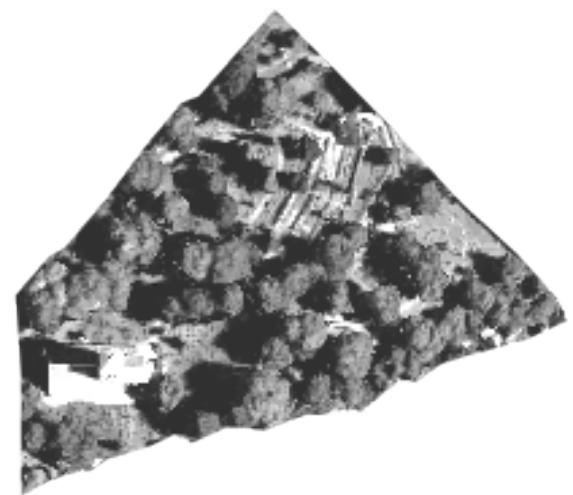

Gamle Aker kirkegård  
(Old Aker Church) Oslo

28,168 m<sup>2</sup>

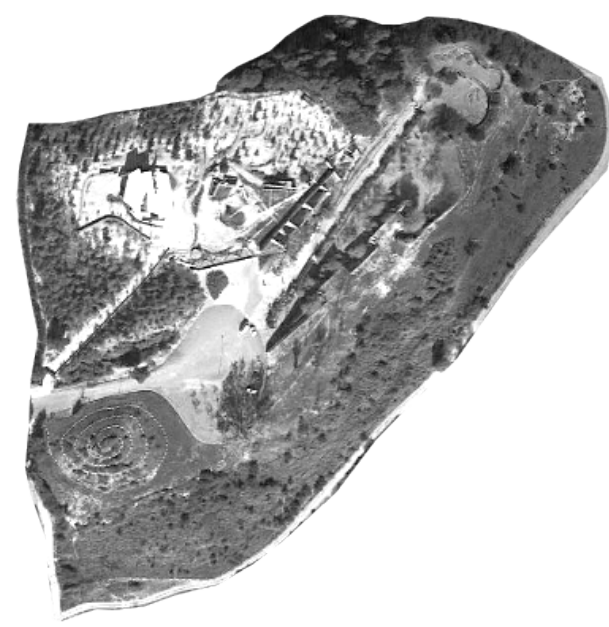
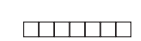

Igualada Cementery  
Barcelona

44,560 m<sup>2</sup>

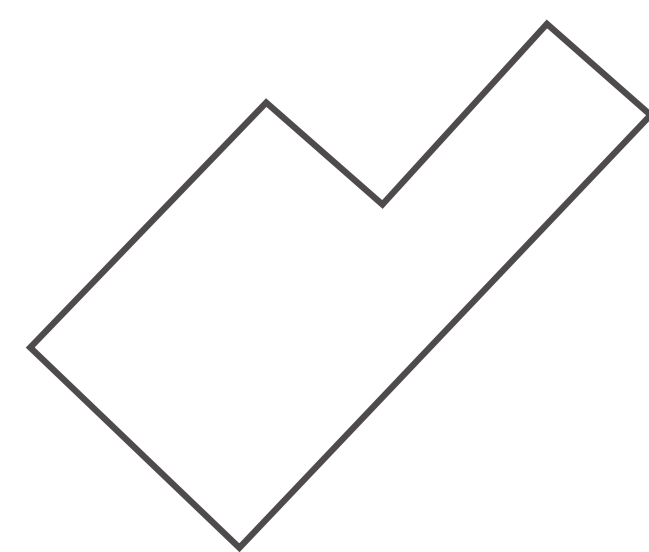
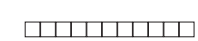

Kai Tak Project  
Hong Kong

approx. 80,000 m<sup>2</sup>

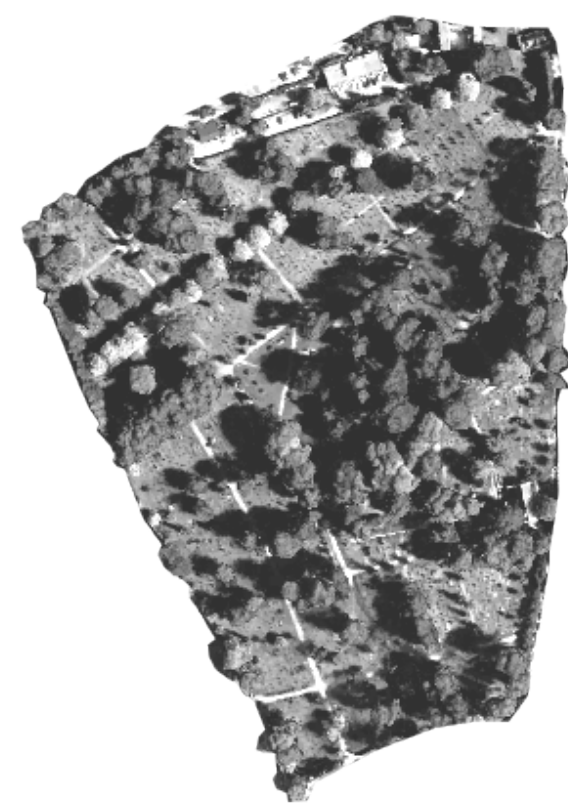
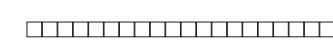

Vår Frelses gravlund  
Oslo

84,856 m<sup>2</sup>

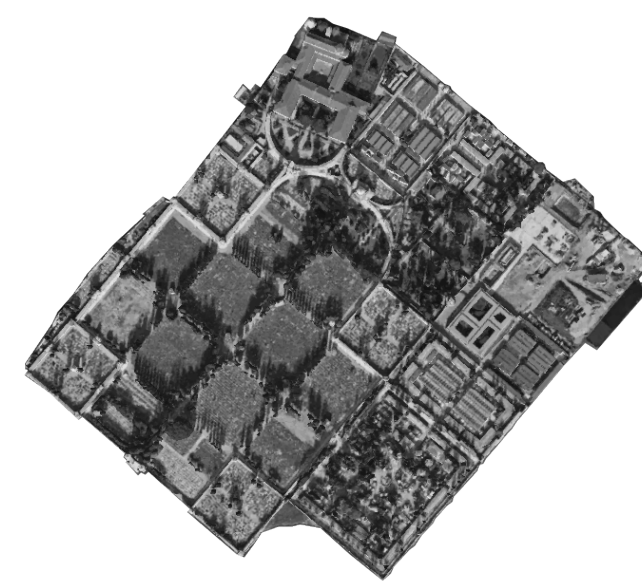
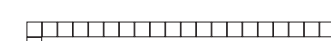

Isola di San Michele  
Venice

168,680 m<sup>2</sup>



Vestre Cemetery  
Copenhagen

540,000 m<sup>2</sup>

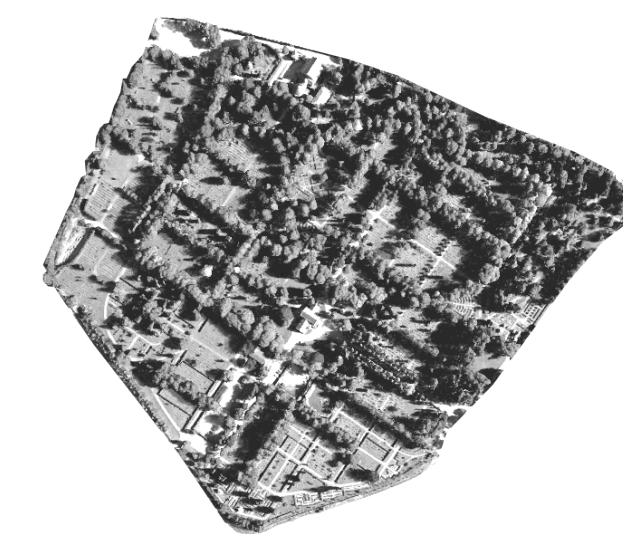
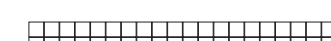

Vestre Cemetery  
Oslo

980,000 m<sup>2</sup>

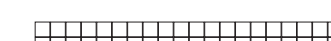

Woodland Cemetery  
Stockholm

1,186,424 m<sup>2</sup>











## Design Strategies

NATURAL BURIAL

SCARCITY OF SPACE

JOURNEYS

LIFELESS

OPENNESS

FEAR OF DEATH

SITE CHARACTER

DISCONNECTION

CONTEXT AND PROBLEMATICS

DESIGN CONCEPT

SITE SELECTION

**DESIGN STRATEGIES**

THE DESIGN & PROCESS

PROJECT VISION



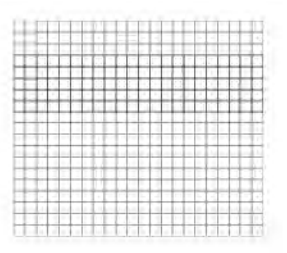
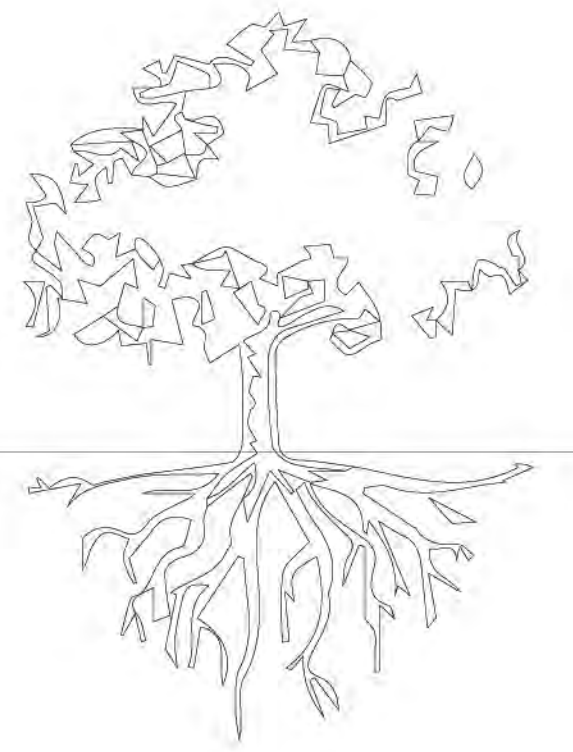
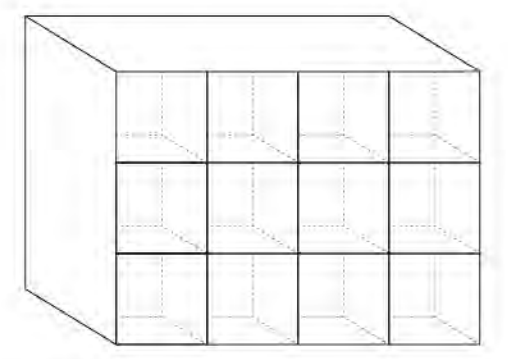
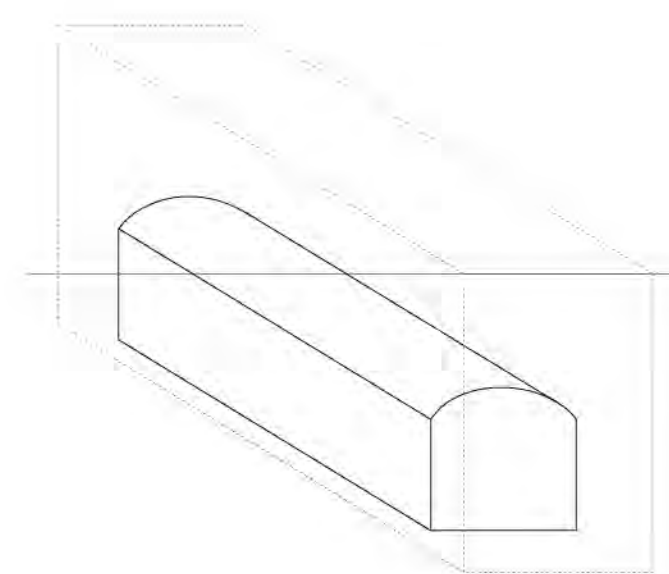
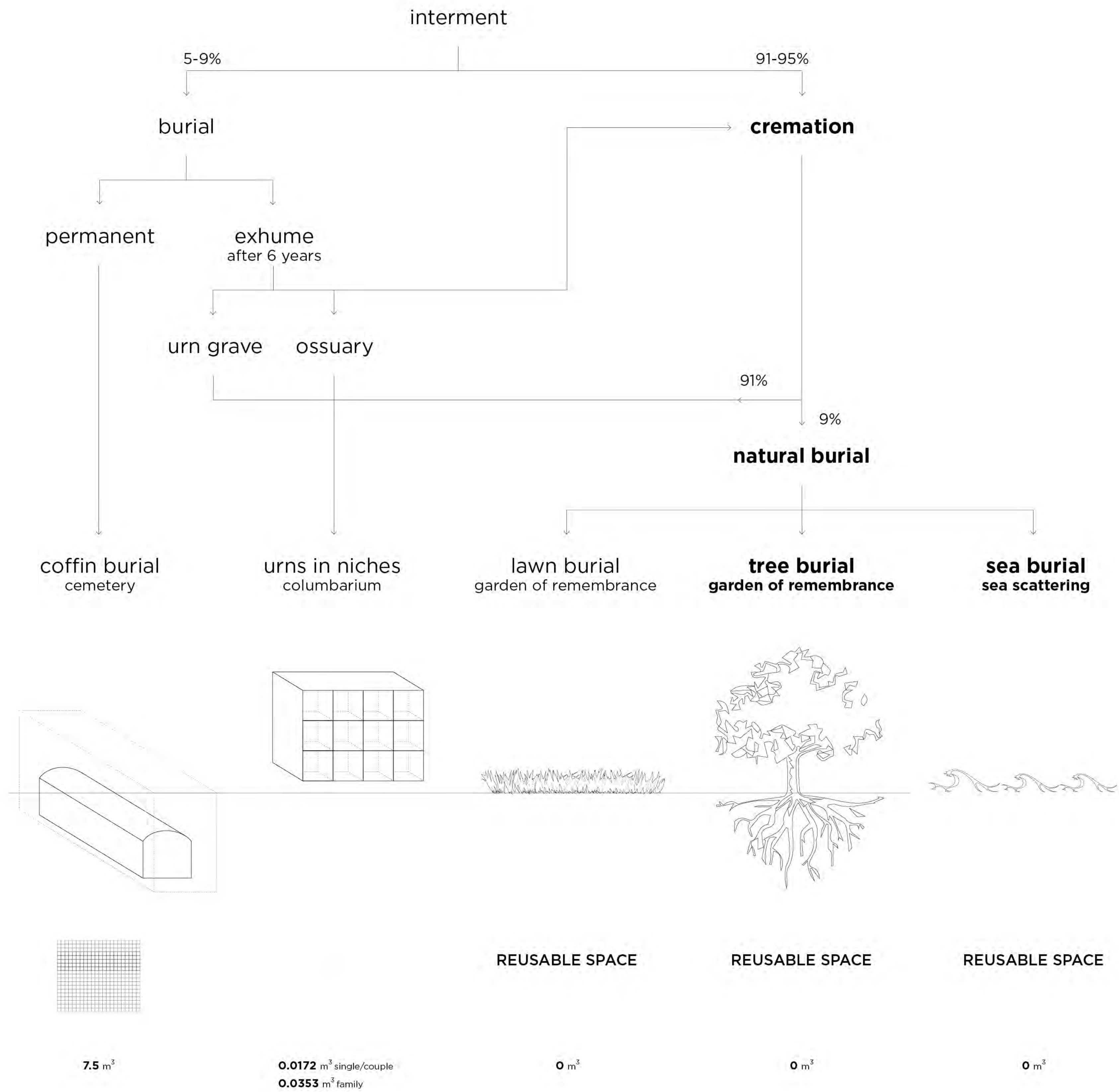

REUSABLE SPACE

REUSABLE SPACE

REUSABLE SPACE

first time visitor  
the bereaved



revisiting mourners



local residents

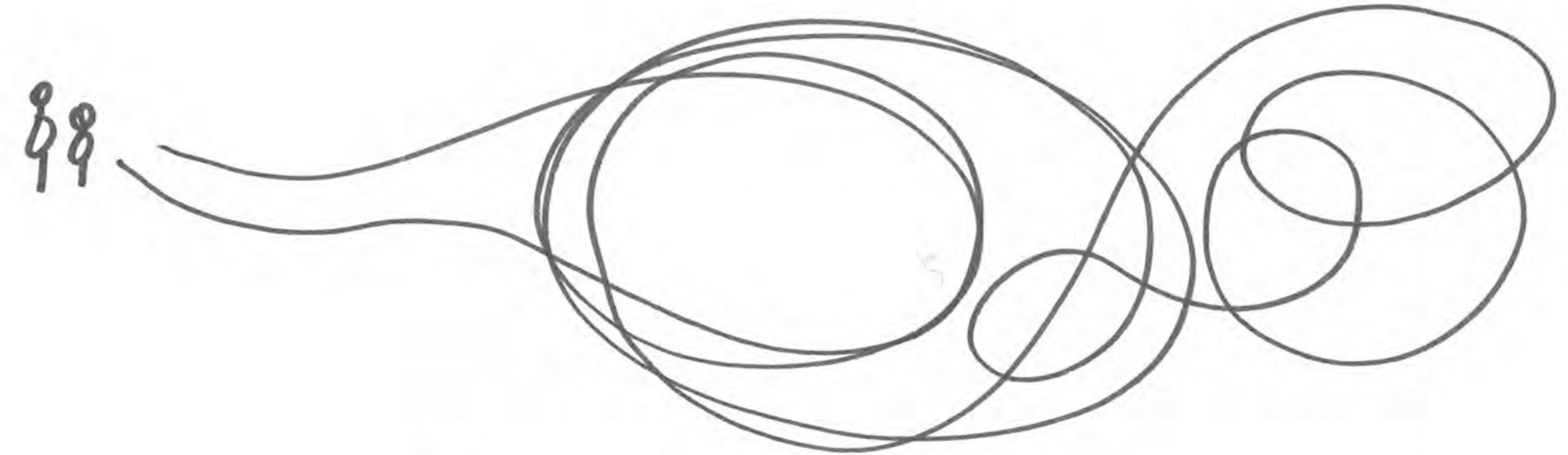

tourist  
one-time visitor

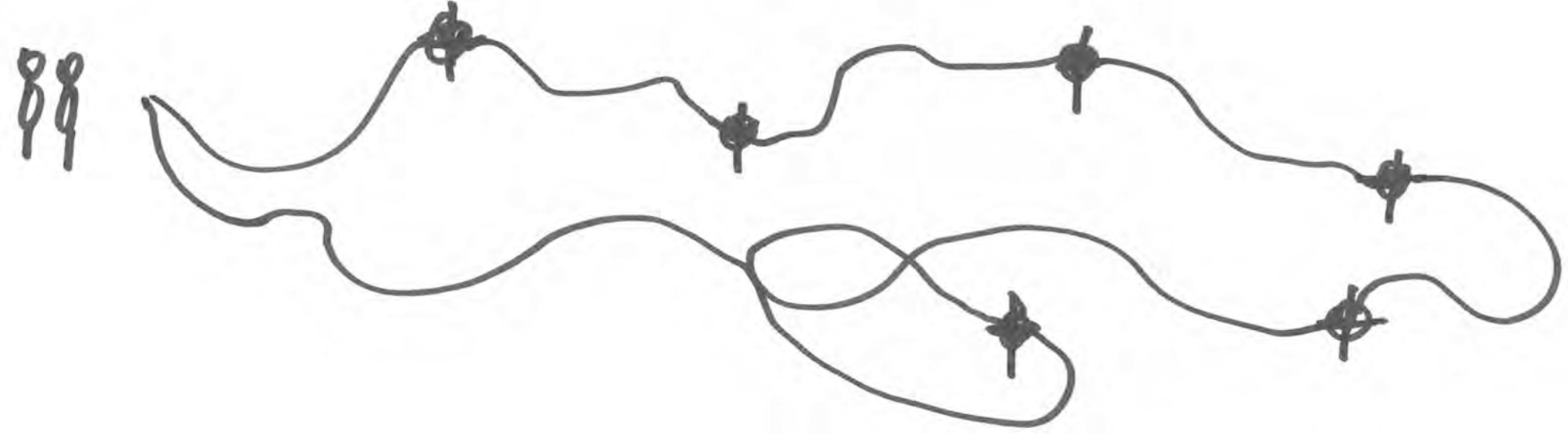

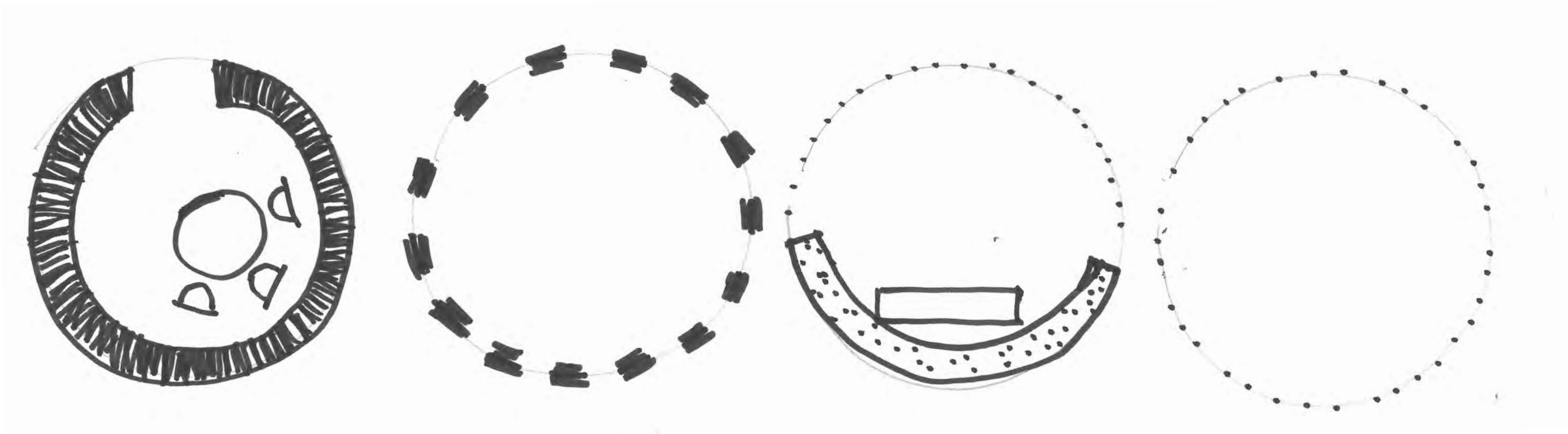

room

permeable fence

semi-enclosed

open

reflect / escape

burial place

companion / gather

relief / leisure

OPENNESS | PRIVACY

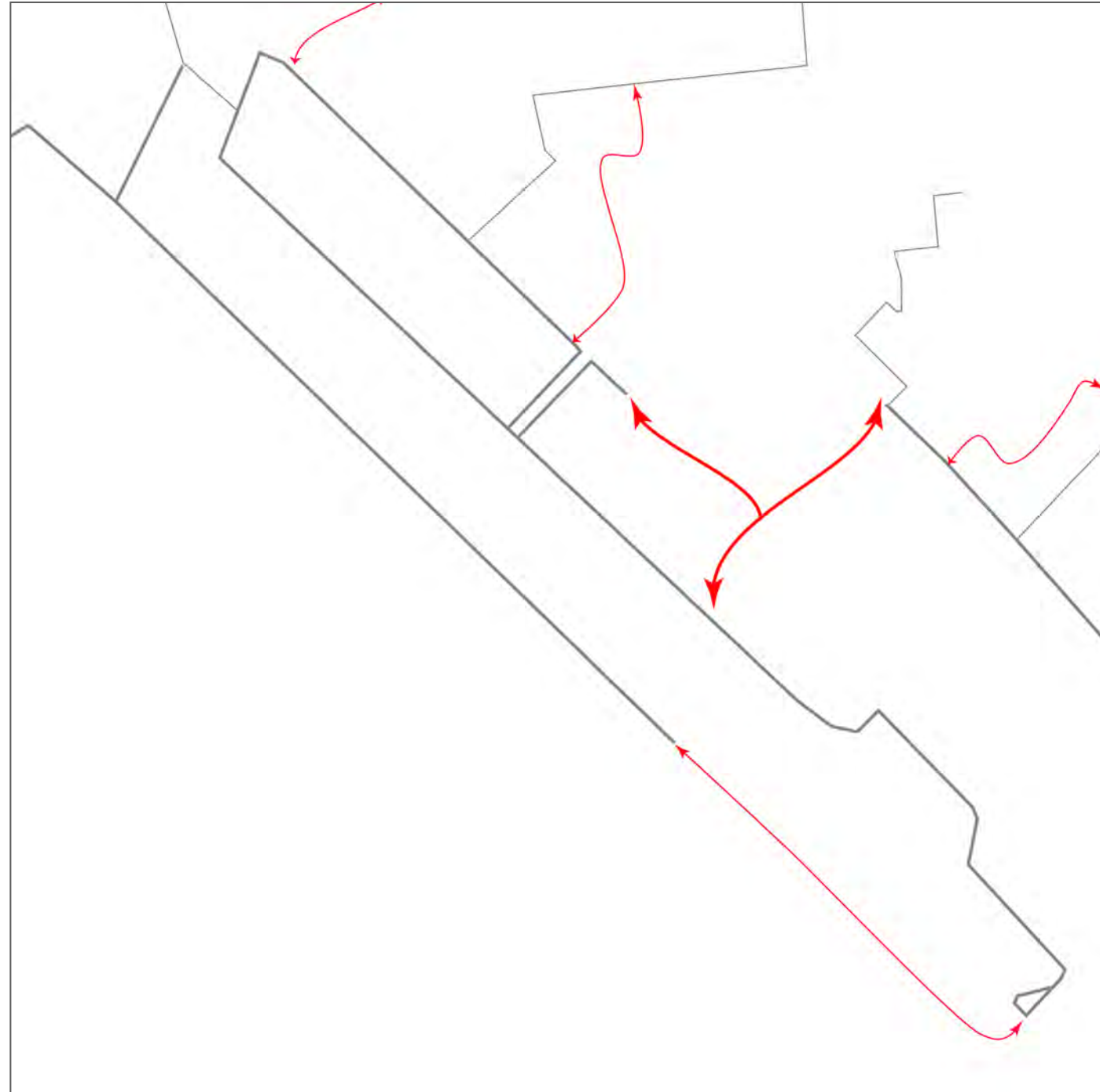

link disconnections

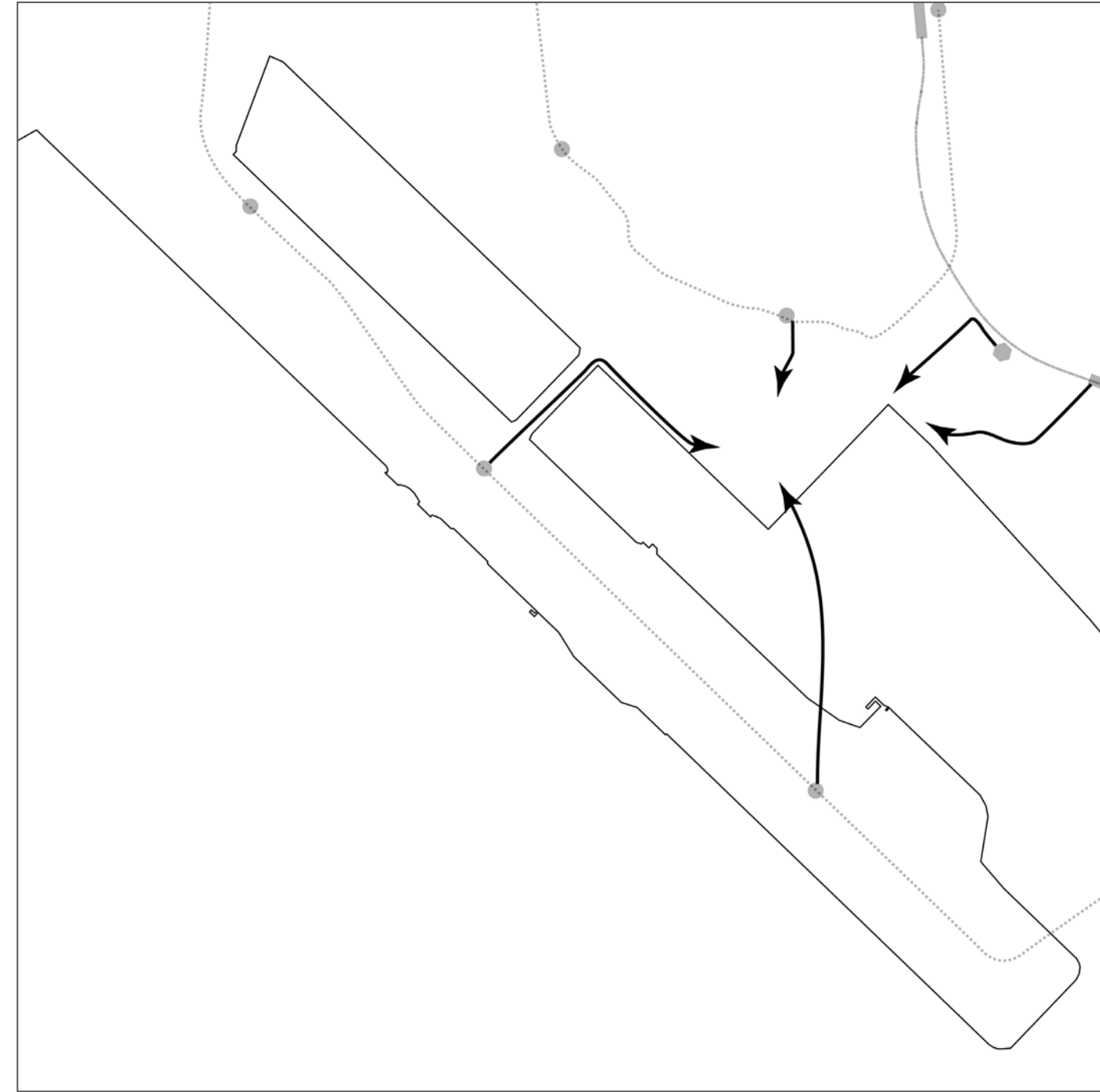

accessibility  
from mass transit railway  
and proposed monorail

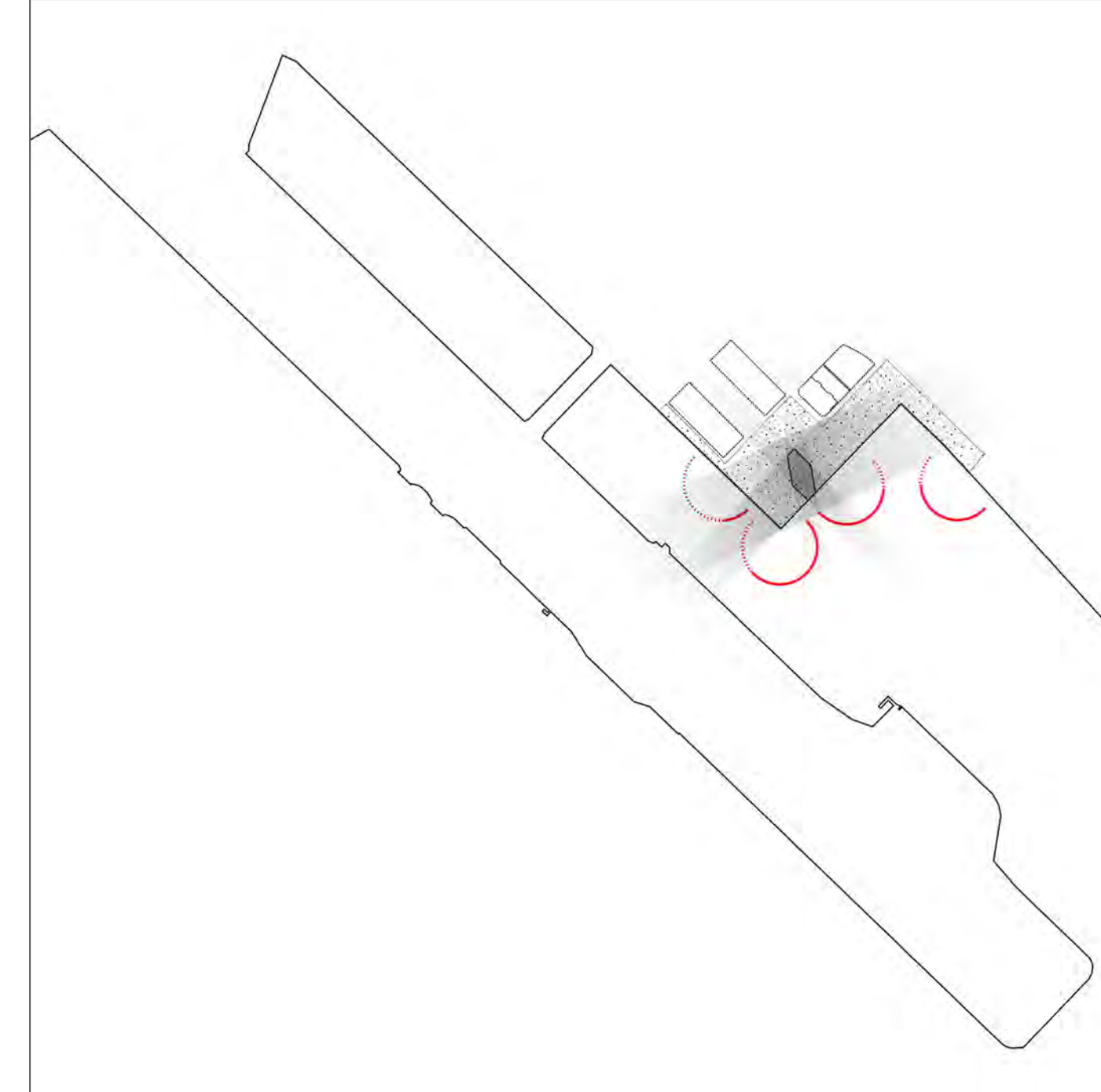

lines of sight  
best view points

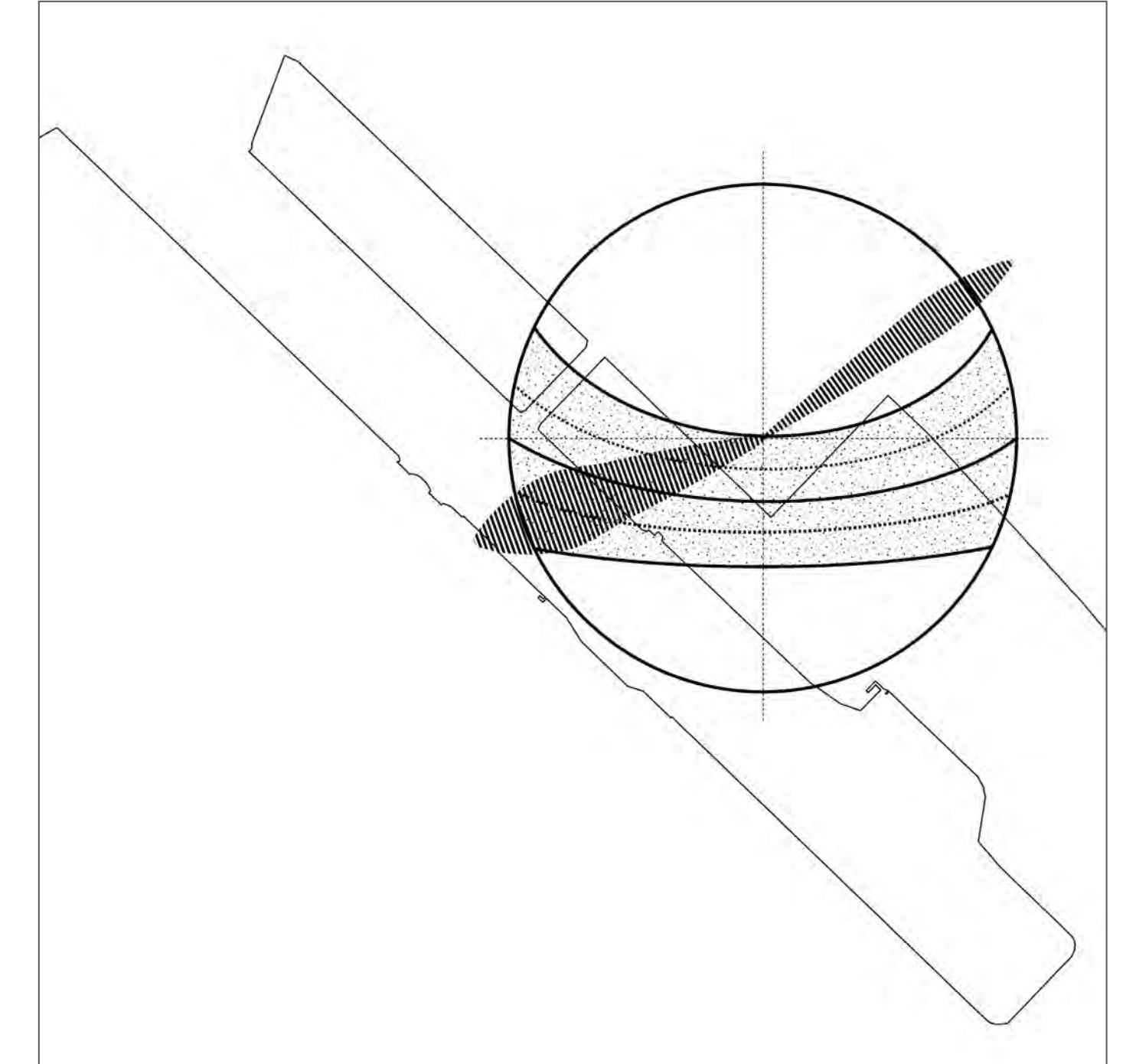

path of sun and wind  
monsoon-influenced humid  
subtropical climate

SITE CHARACTERISTICS



## **The Design & Process**

MOOD PAINTINGS

JOURNEYS

HUMAN PERSPECTIVES

CONTEXT AND PROBLEMATIC

DESIGN CONCEPT

SITE SELECTION

DESIGN STRATEGIES

**THE DESIGN & PROCESS**

PROJECT VISION

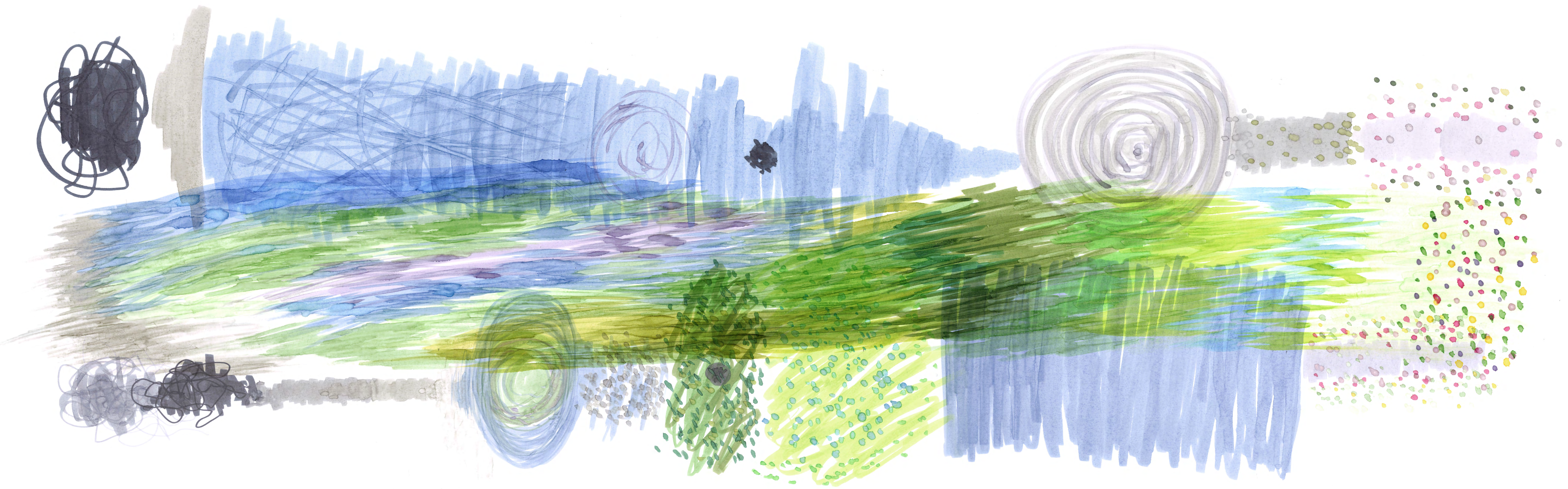

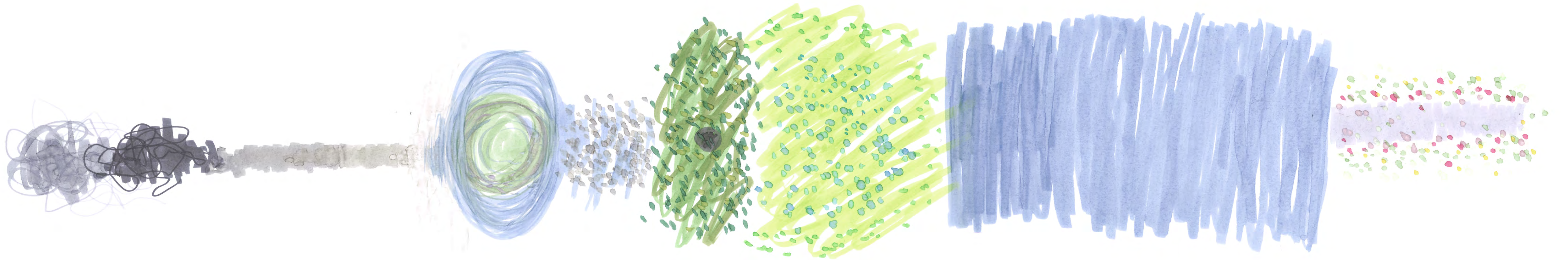

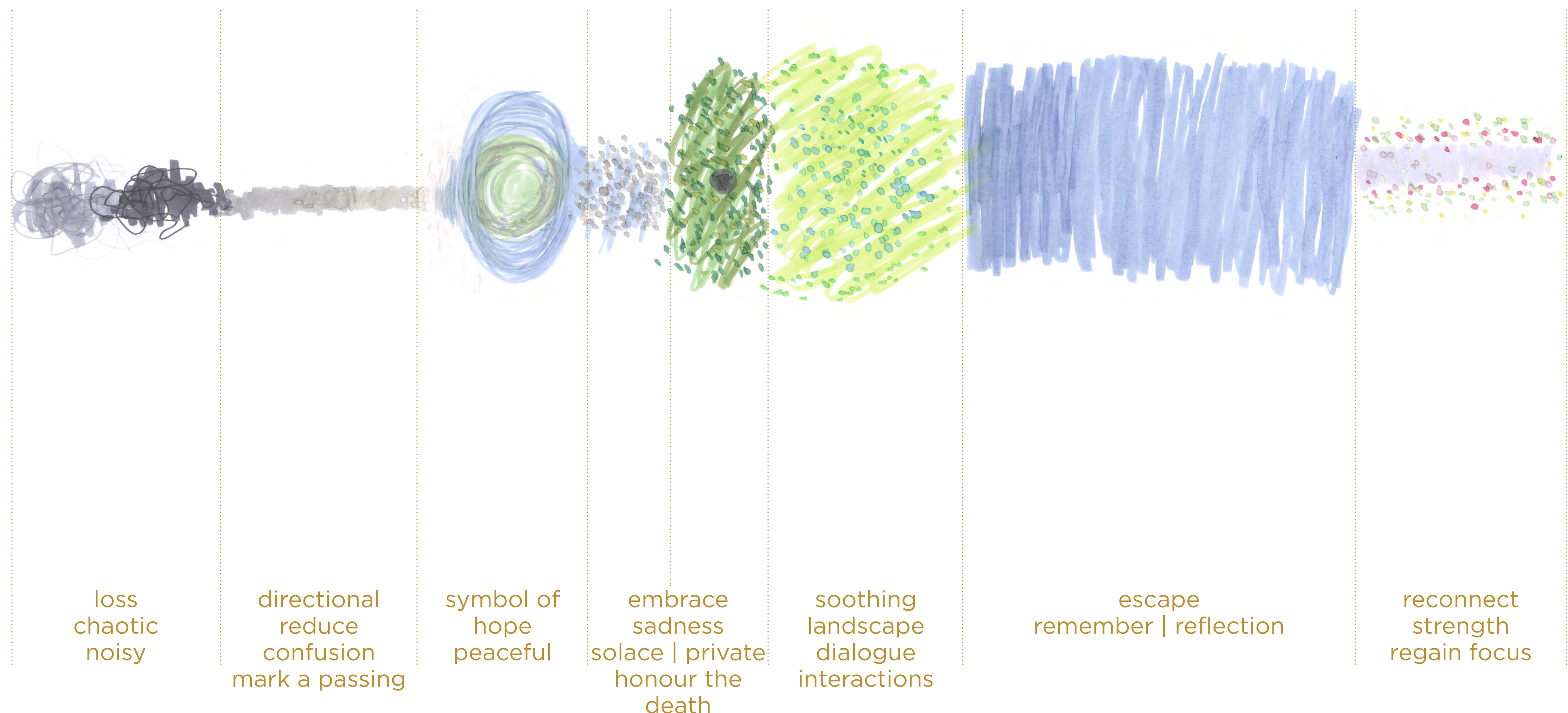

JOURNEY OF THE BEREAVED'S FIRST VISIT - TREE BURIAL



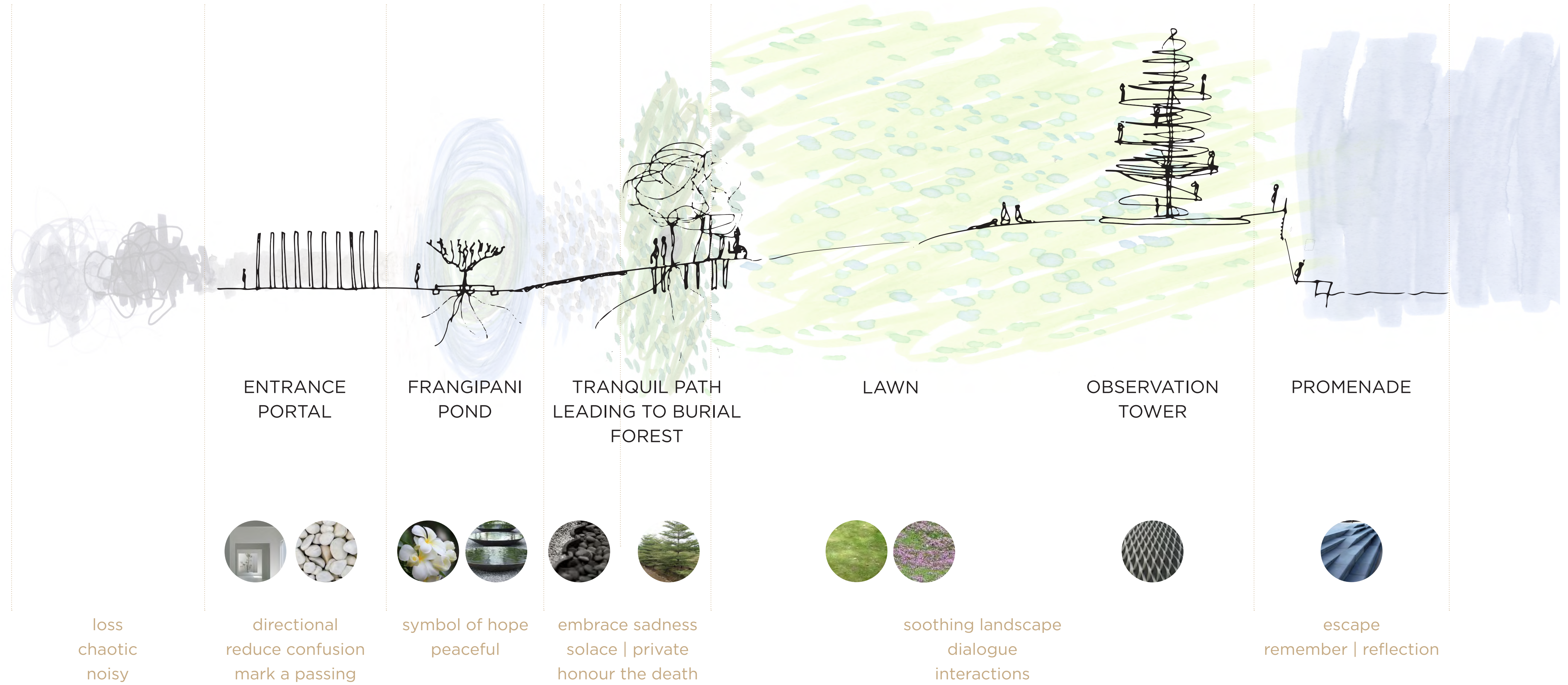

CONCEPTUAL SECTION

journey1  
FIRST TIME VISITOR  
TREE BURIAL

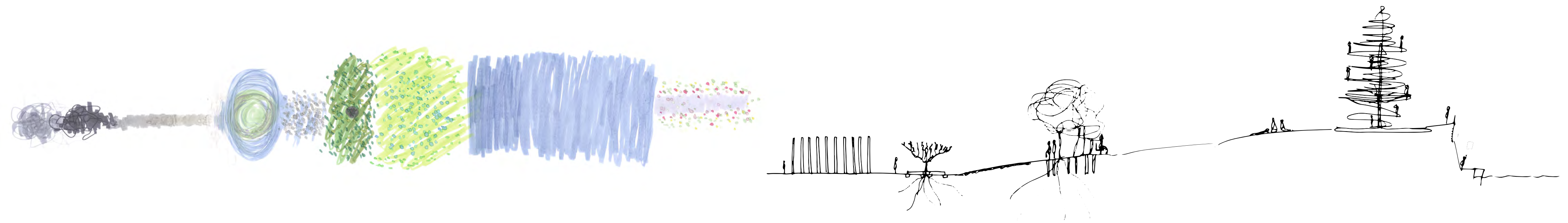

journey2  
FIRST TIME VISITOR  
SEA BURIAL

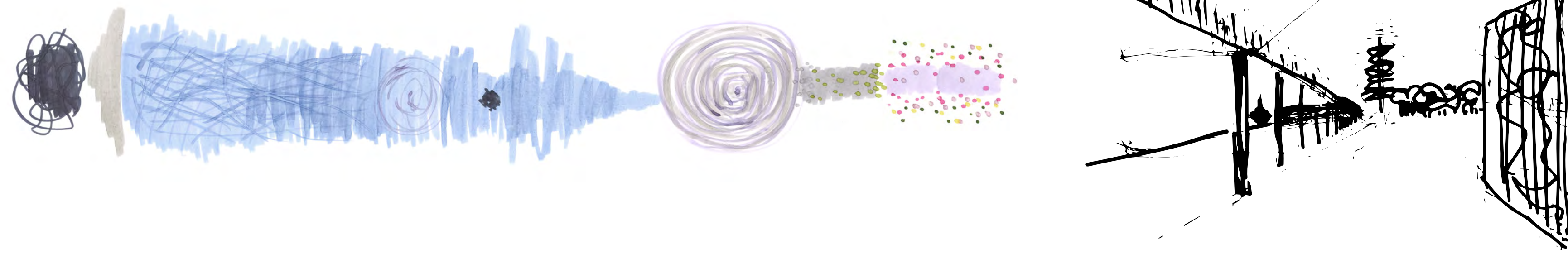

journey3  
LOCALS



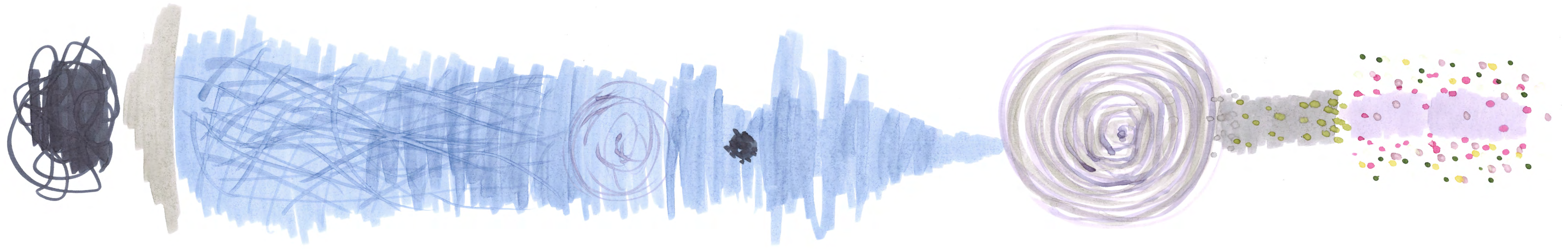

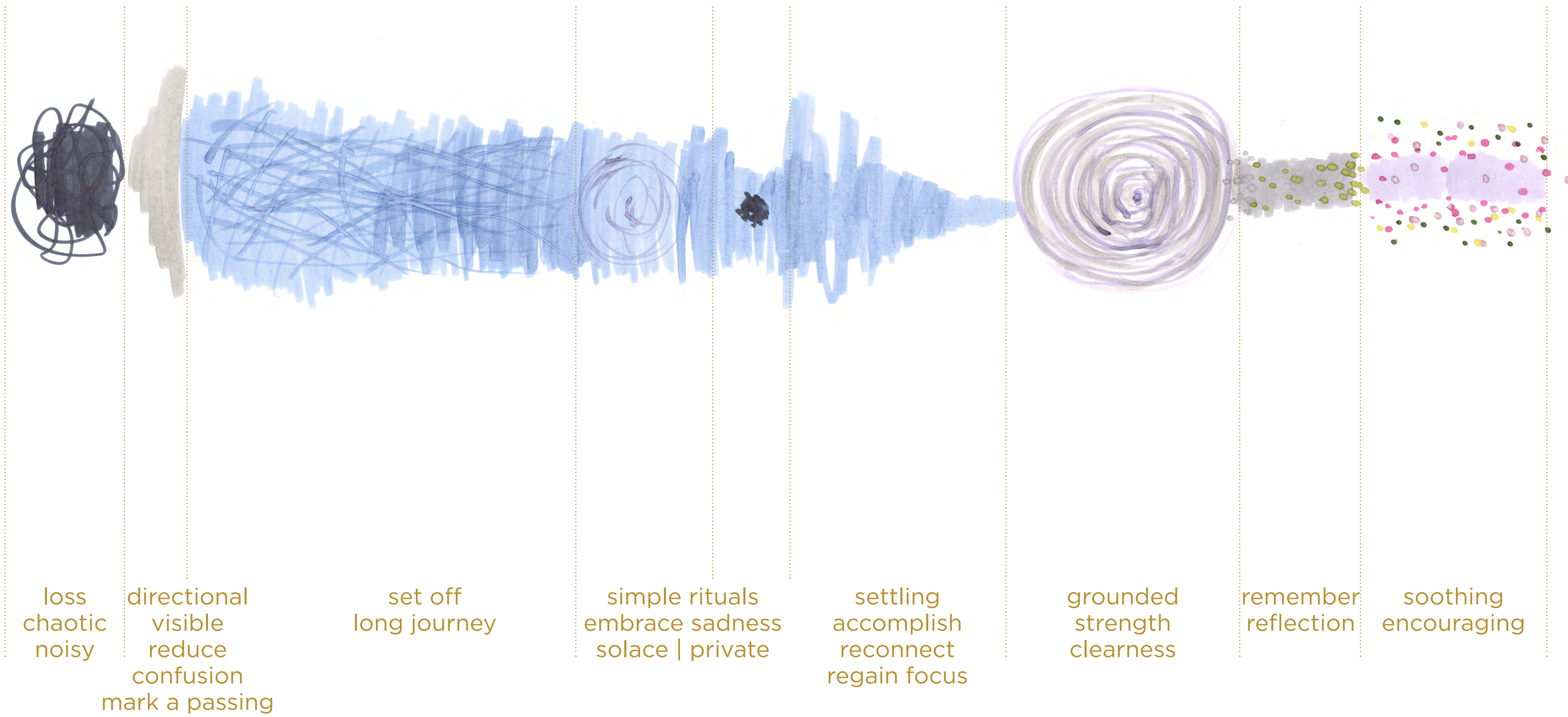

JOURNEY OF THE BEREAVED'S FIRST VISIT - SEA BURIAL





chaotic  
noisy

gorgeous harbourfront  
enjoy sea breeze  
embrace the nature

lush greenery  
relaxing landscape  
trees and shades  
lawns and activities

adorable  
flowers  
strength  
encouraging

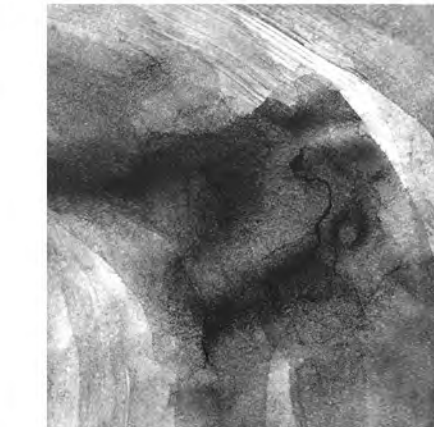
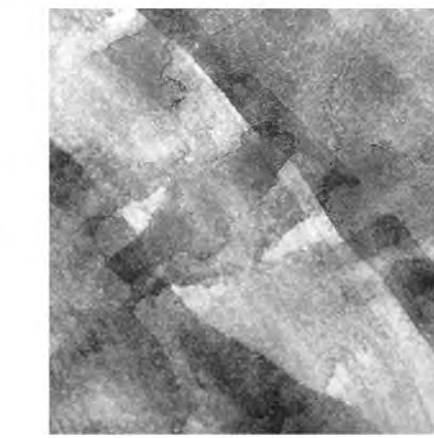
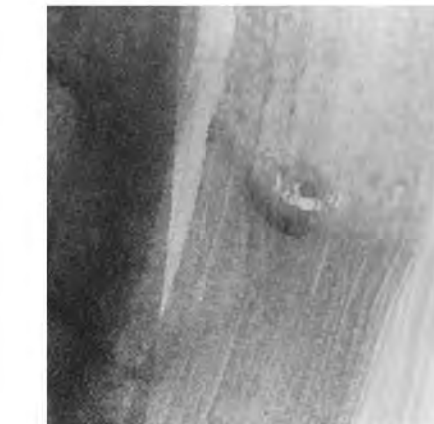
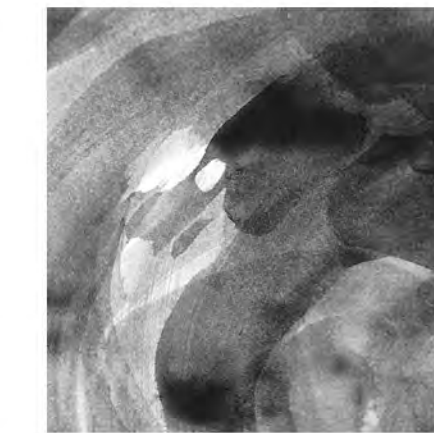
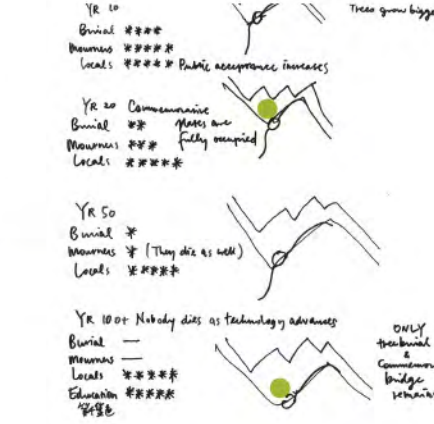
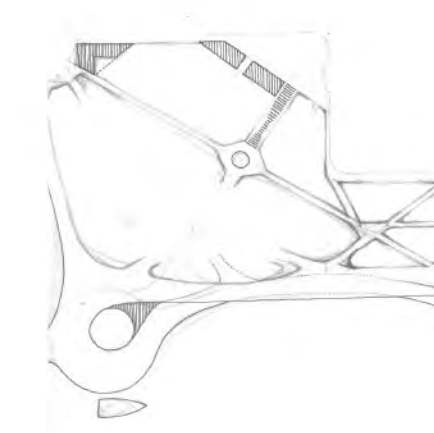
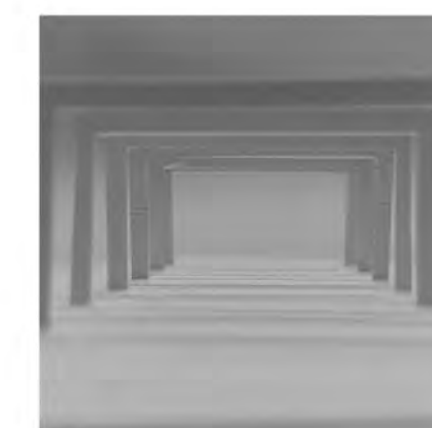
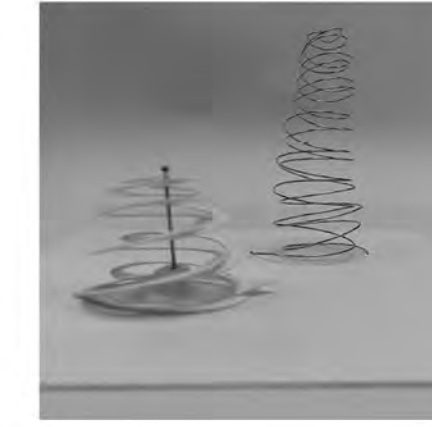
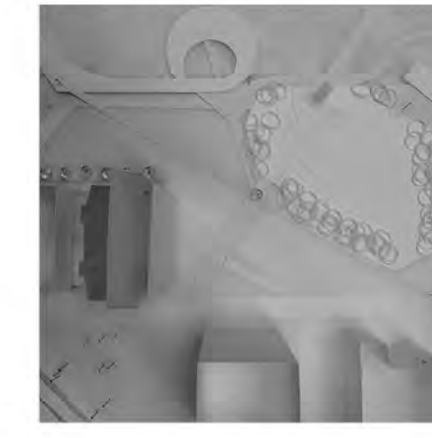
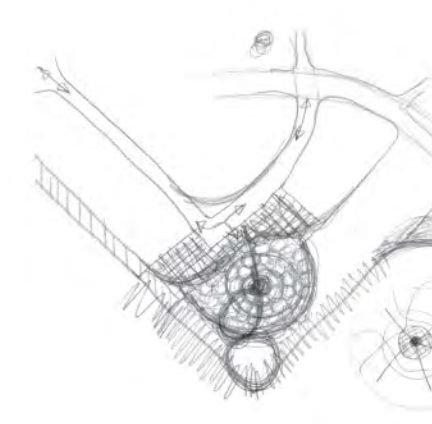
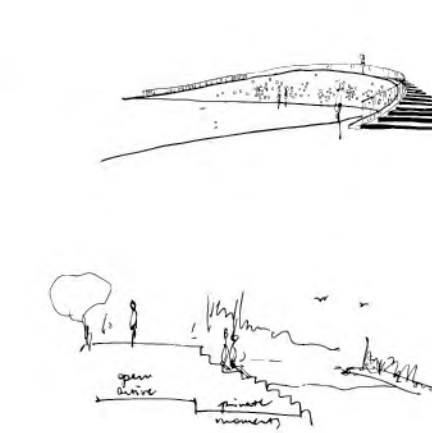
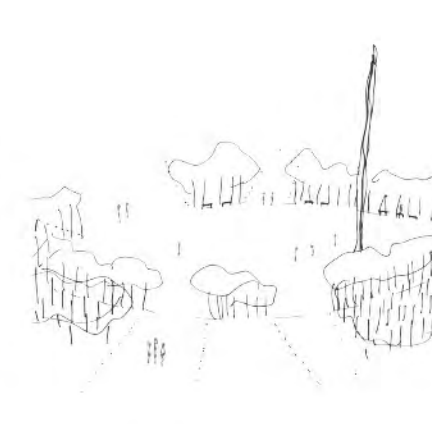
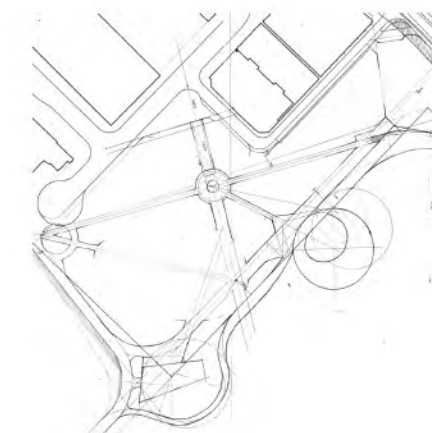
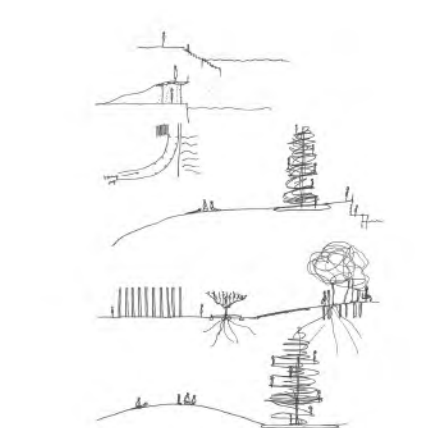
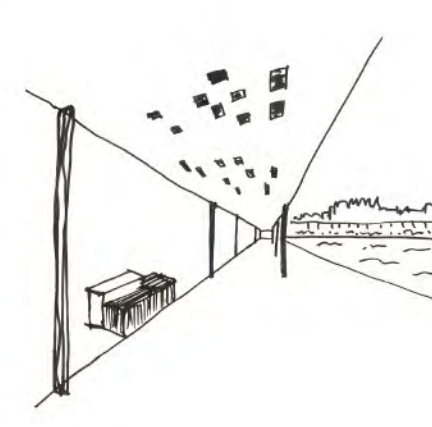
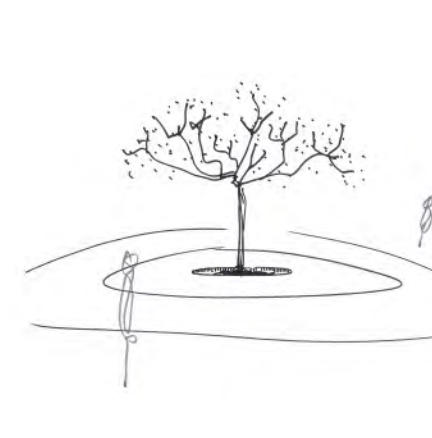
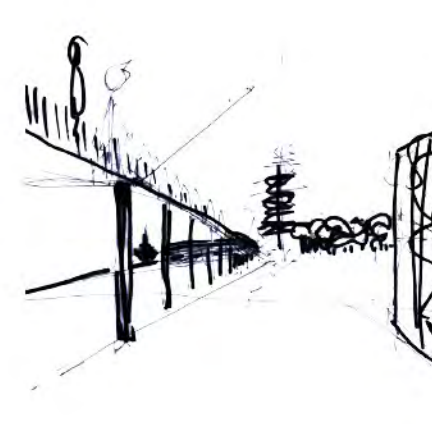
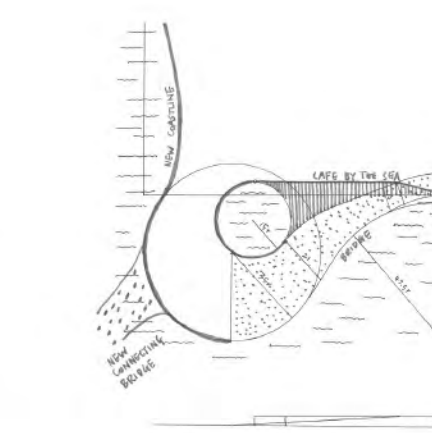
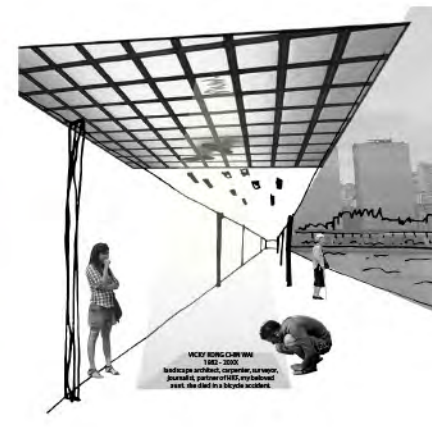
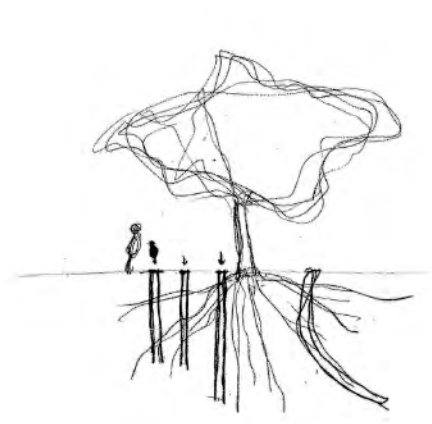
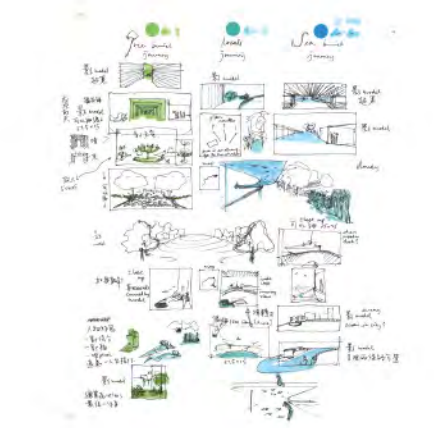
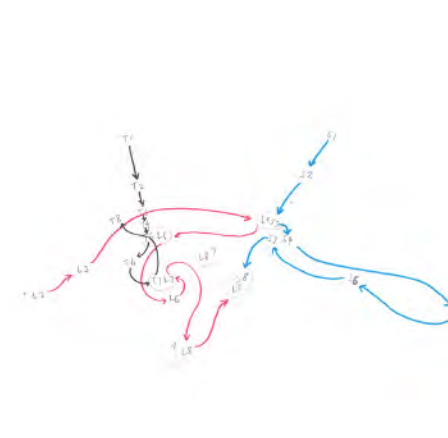
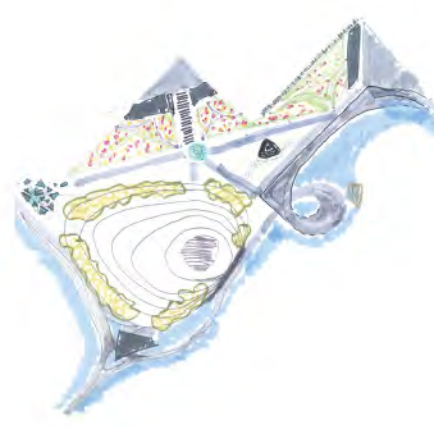
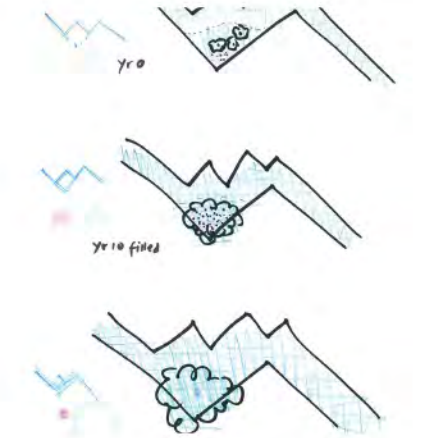
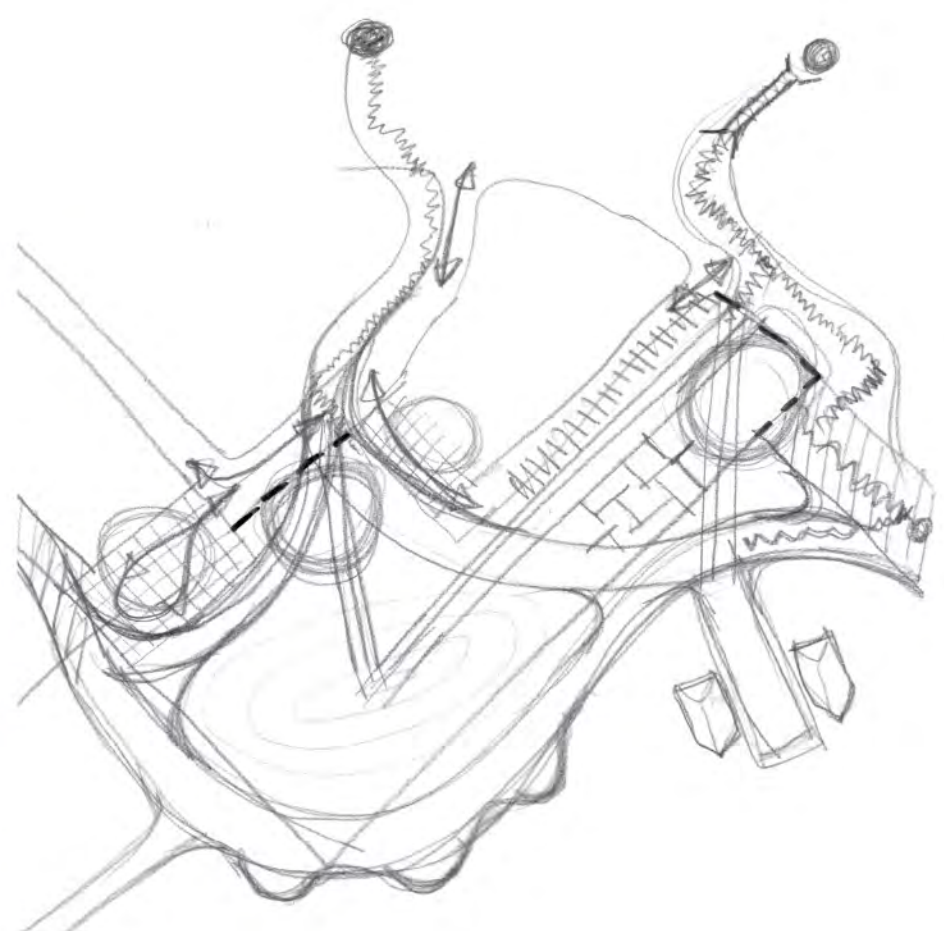
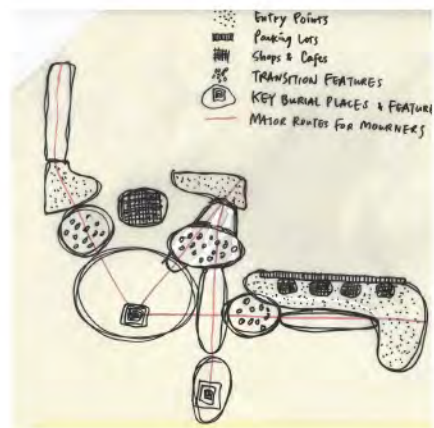
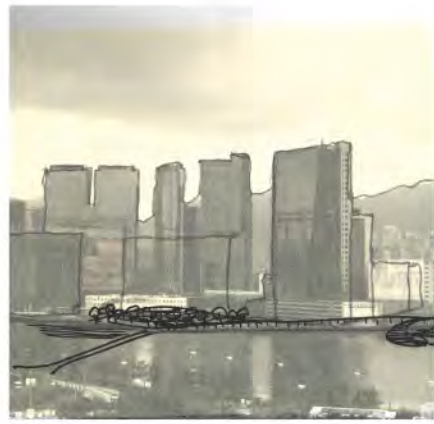
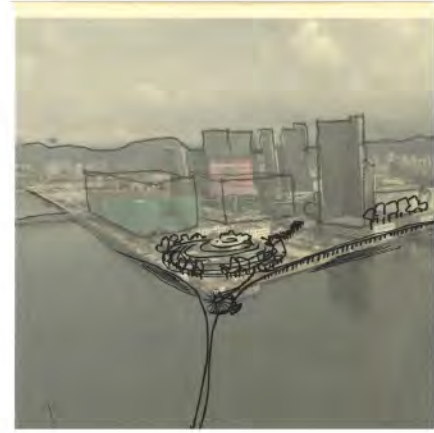

DESIGN PROCESS



Intense Emotion of first-time visit

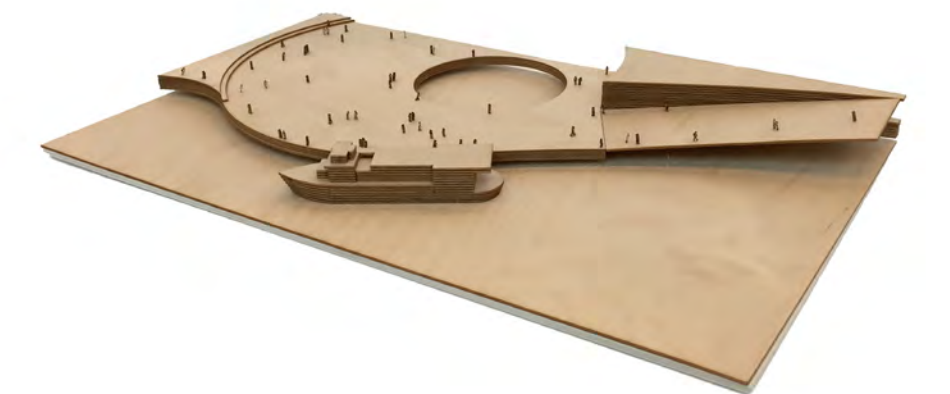
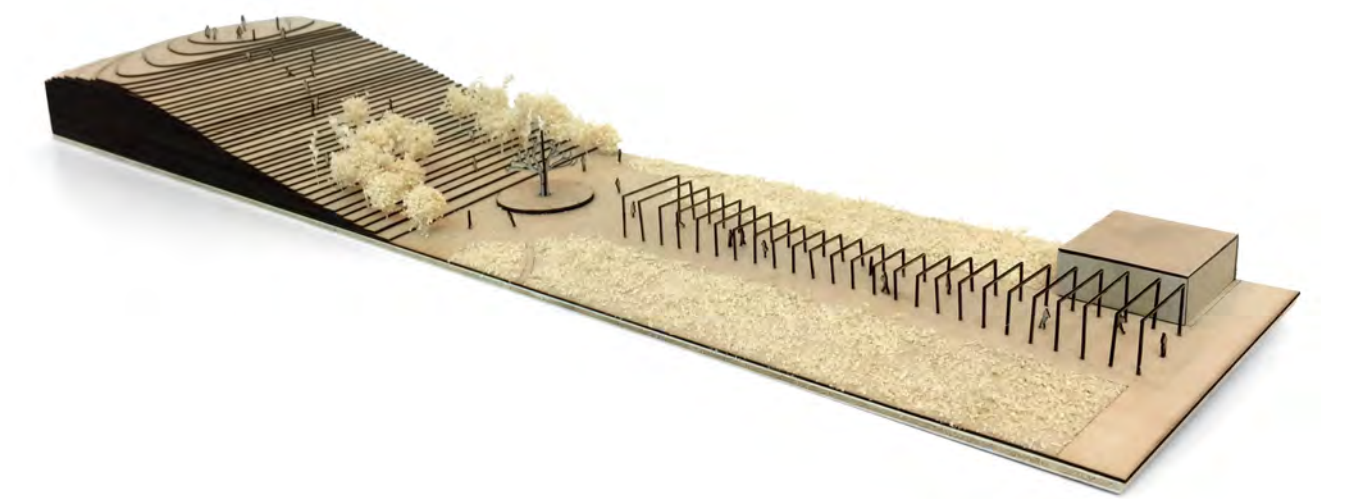
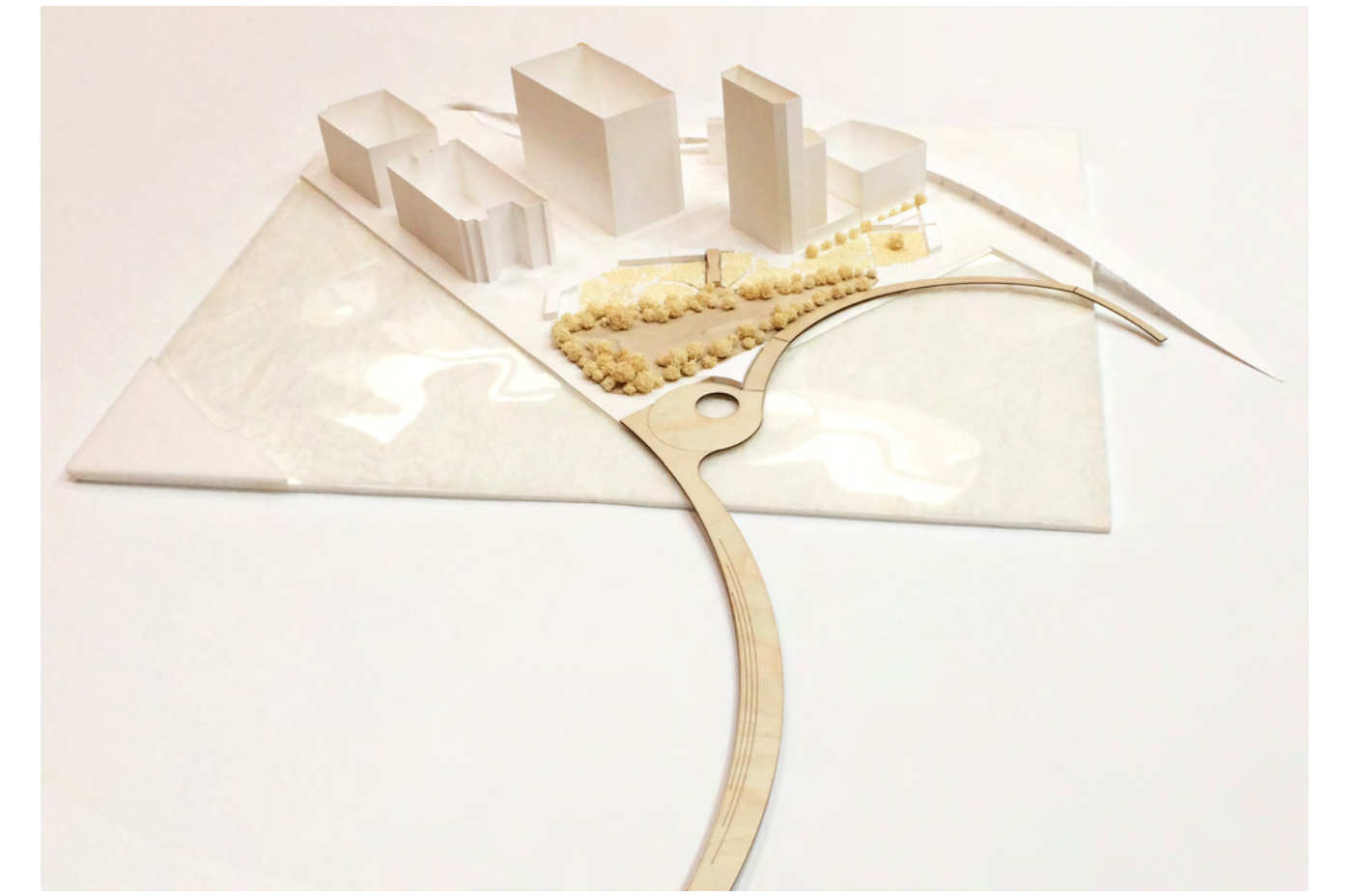



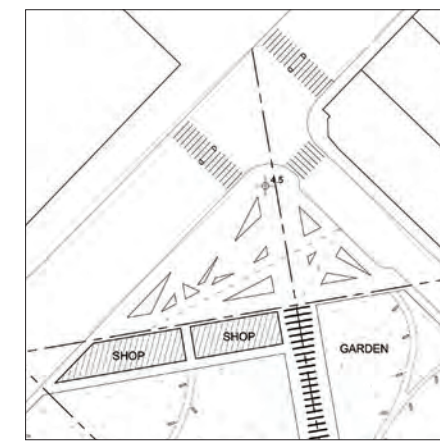
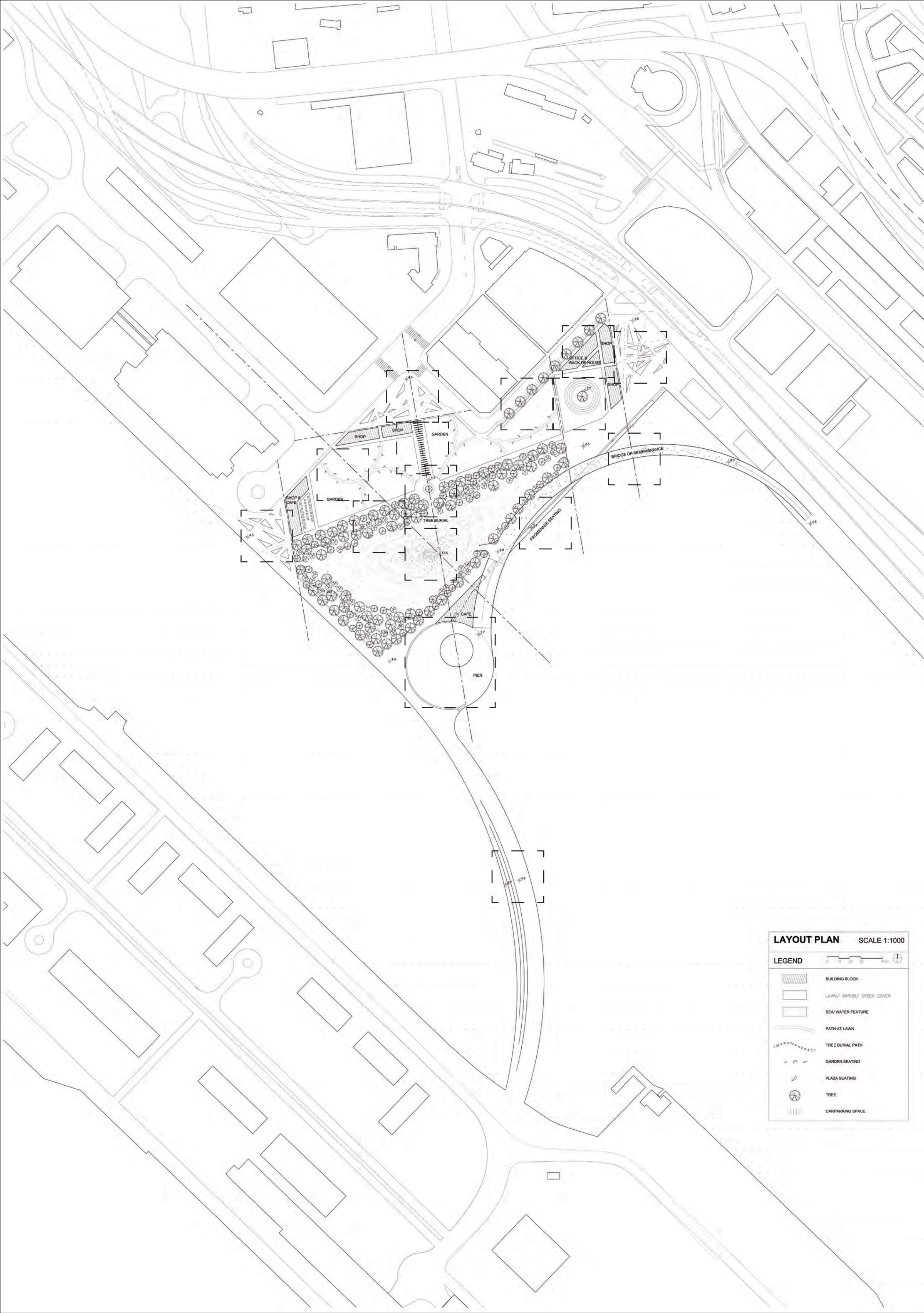

Entrance Plaza  
[Tree Burial]

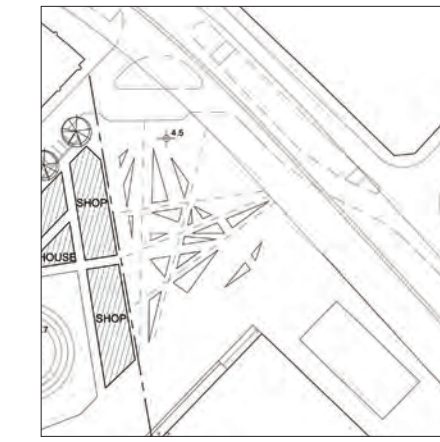

Entrance Plaza  
[Sea Burial]

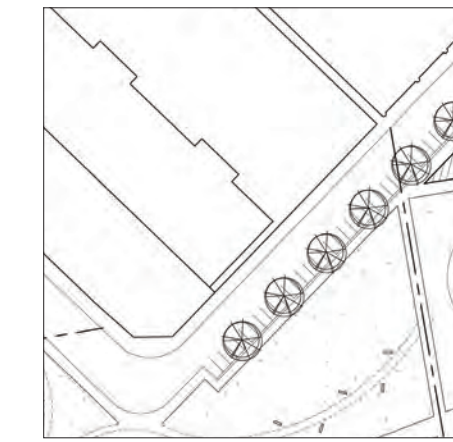

Tree-shade Parking

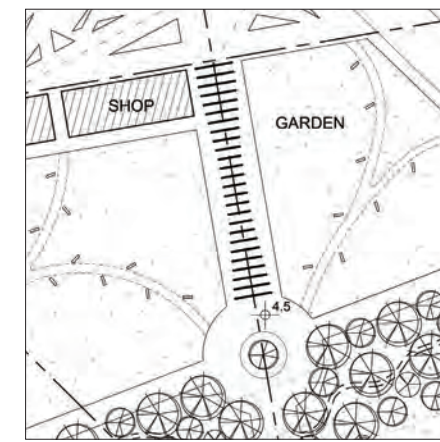

Portal



Bridge of Remembrance

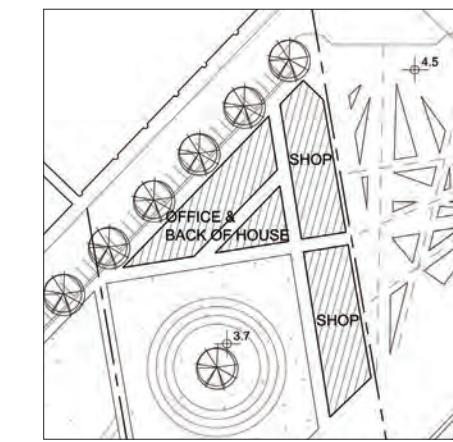

Shops [Florist]  
Cafes, Offices  
Back of House  
Incinerators for sacrifice/incense

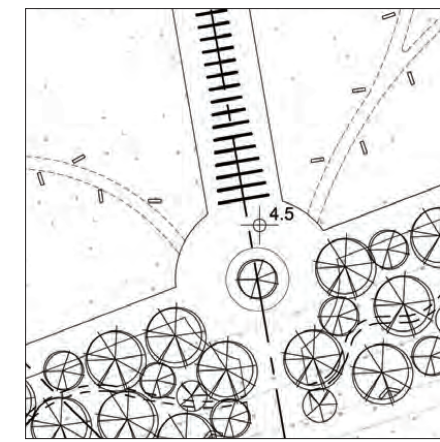

Frangipani Pond



Promenade Seating

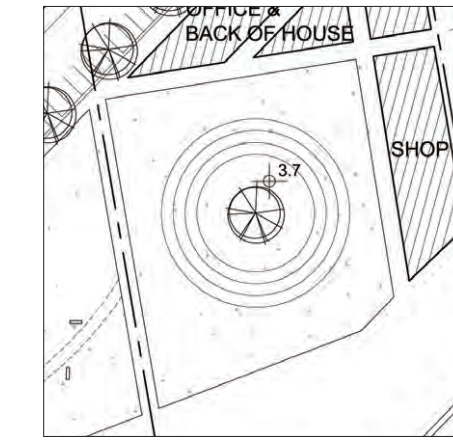

Flower Offering

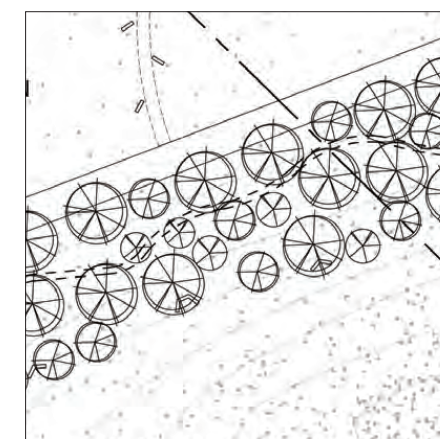

Tree Burial Forest & Lawn

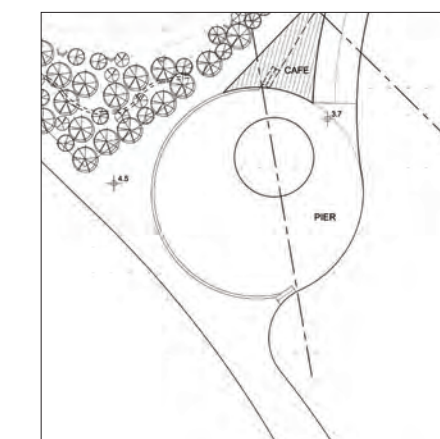

Pier  
[Sea Burial]

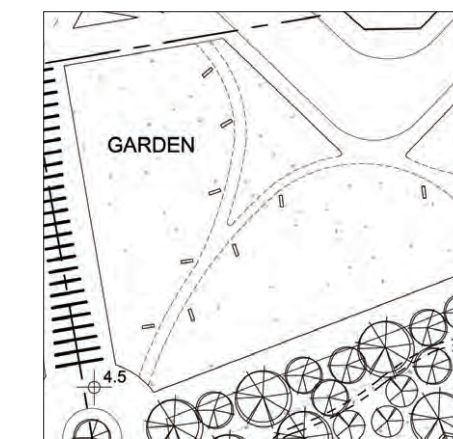

Gardens

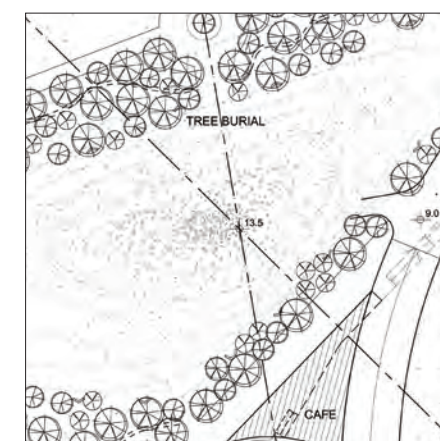

Meditating Hillock

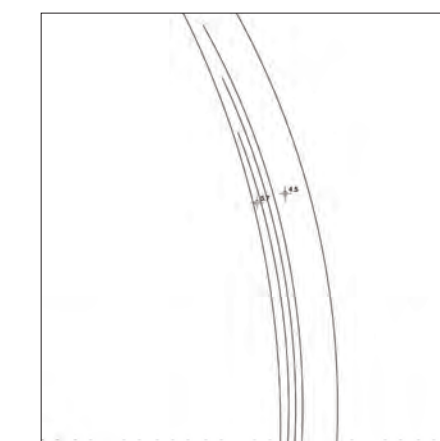

Connecting Bridge  
[to Kai Tak runway]

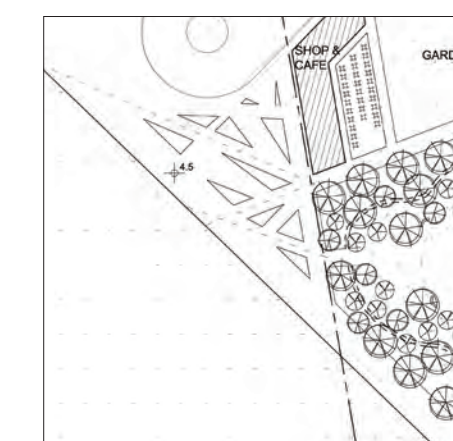

Promenade Entrance  
Plaza

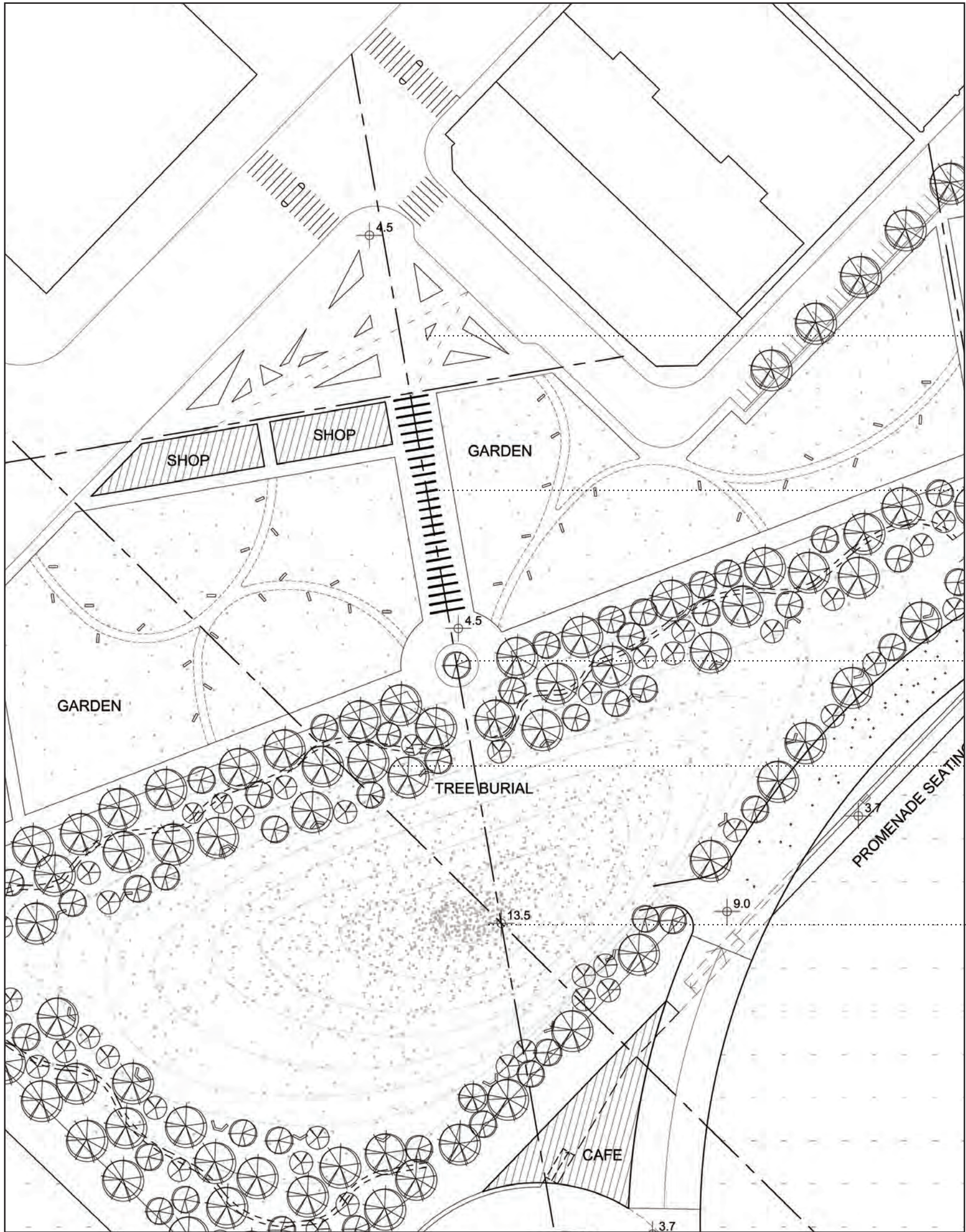

ENTRANCE PLAZA  
[TREE BURIAL]

PORTAL

FRANGIPANI POND

TREE BURIAL FOREST & LAWN

MEDITATING HILLOCK

















BRIDGE OF REMEMBRANCE

PIER  
[SEA BURIAL]

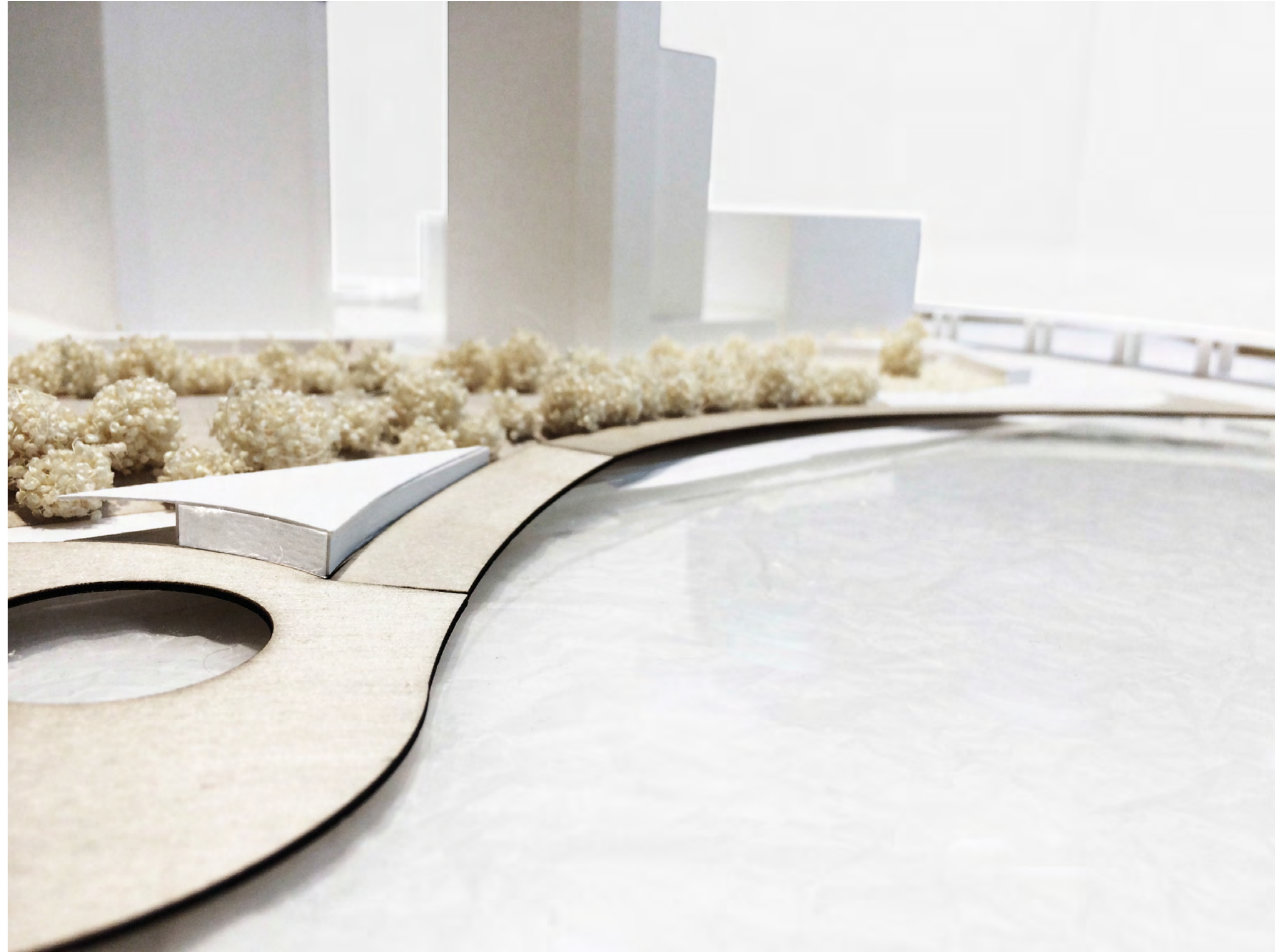

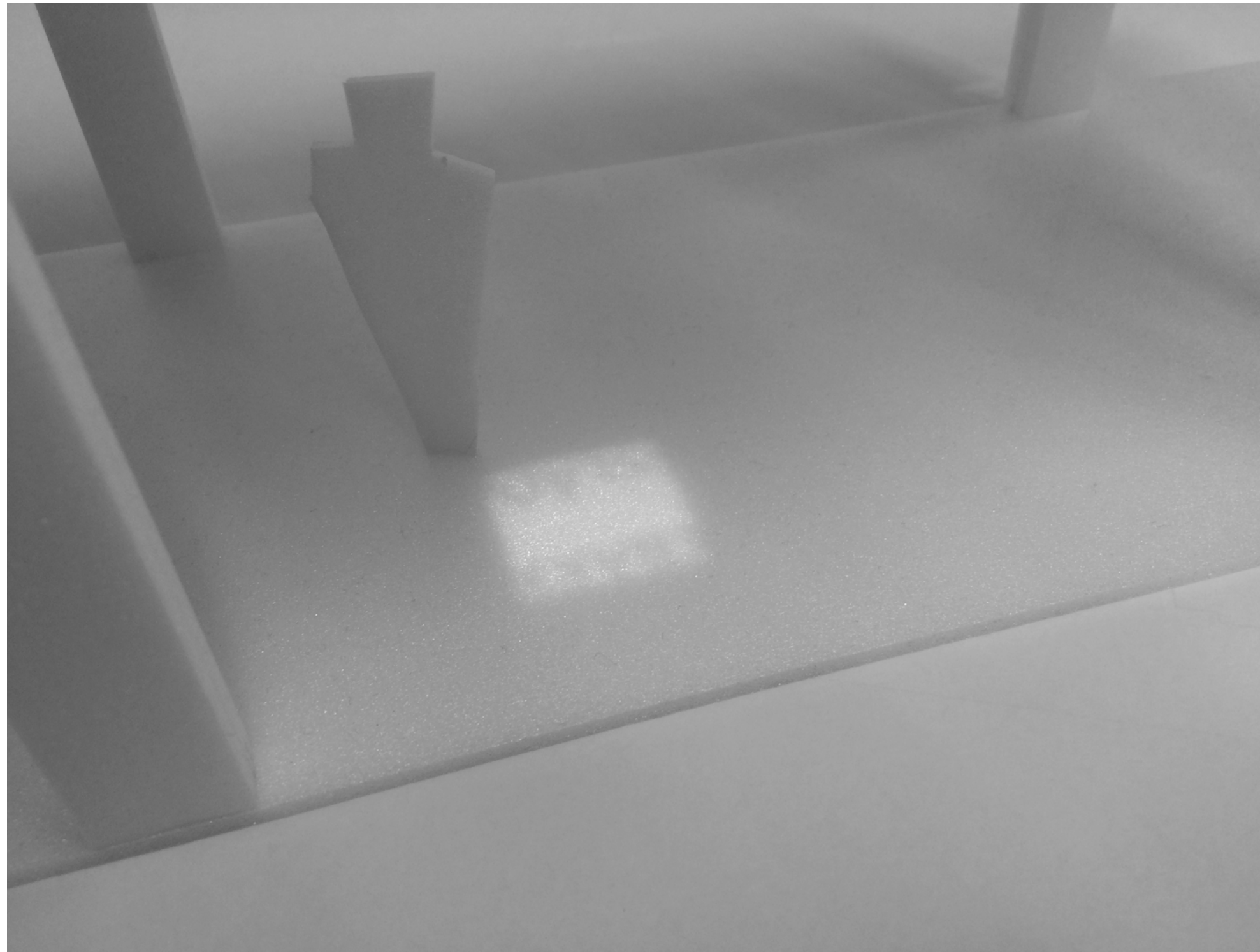
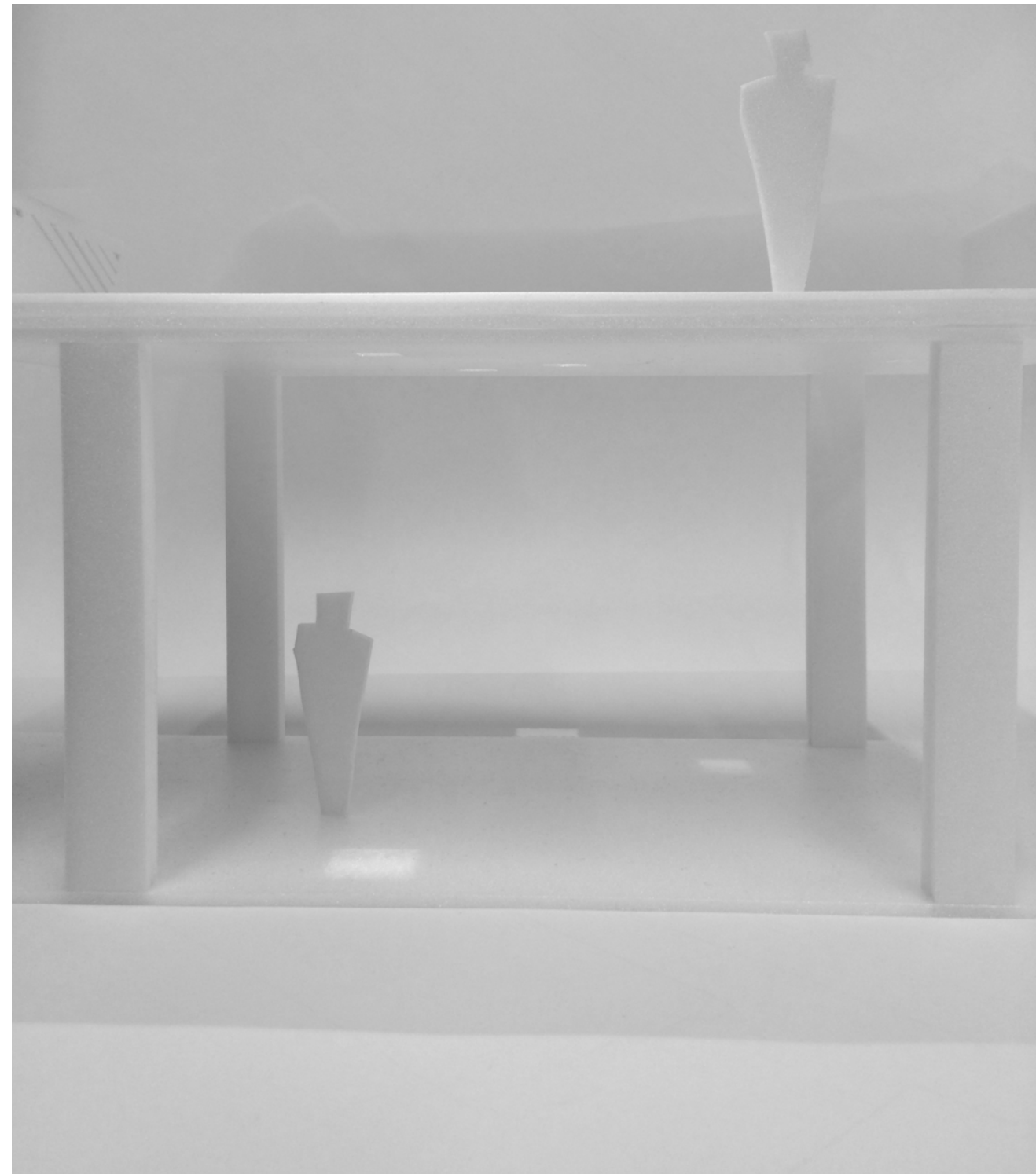
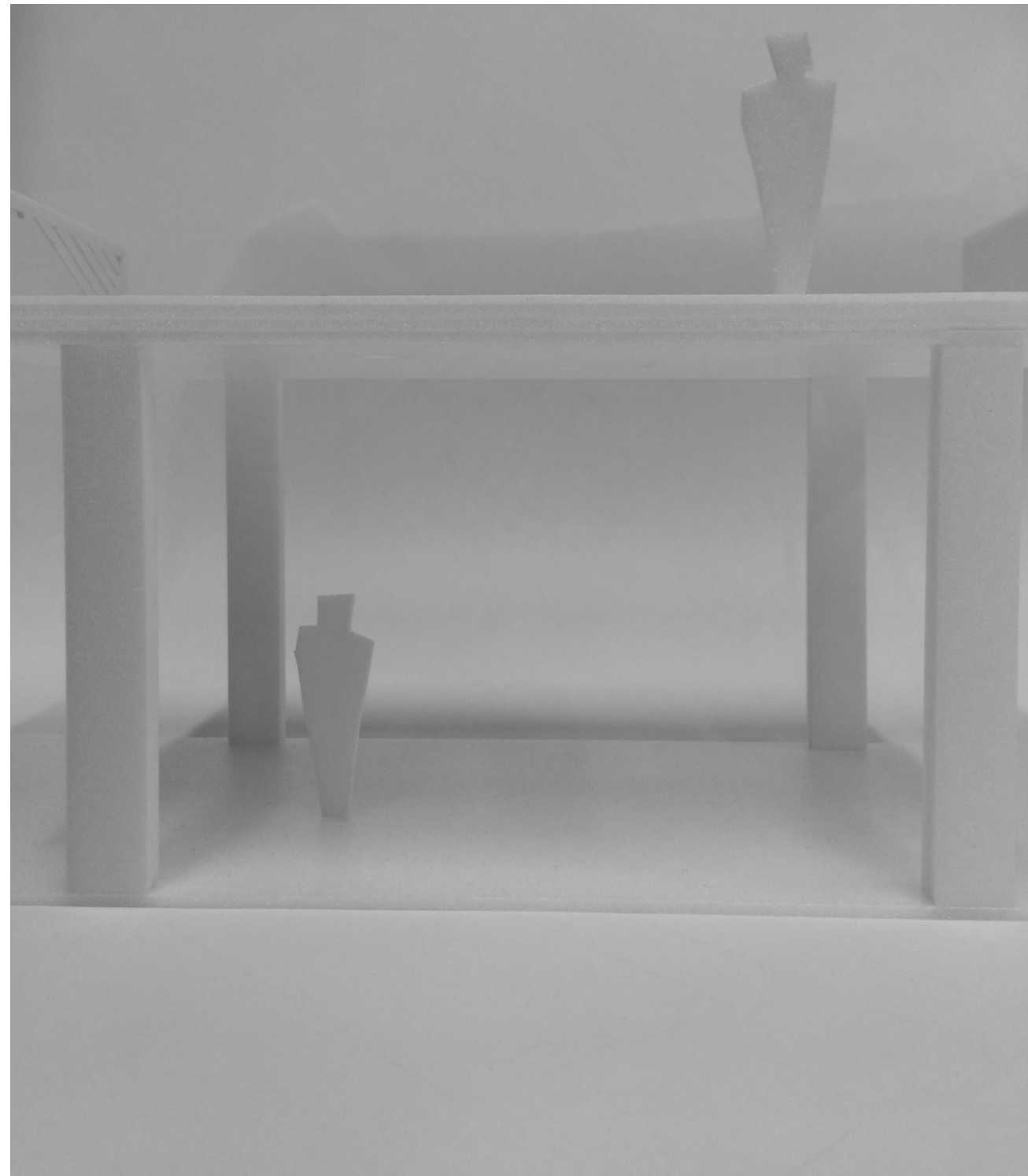



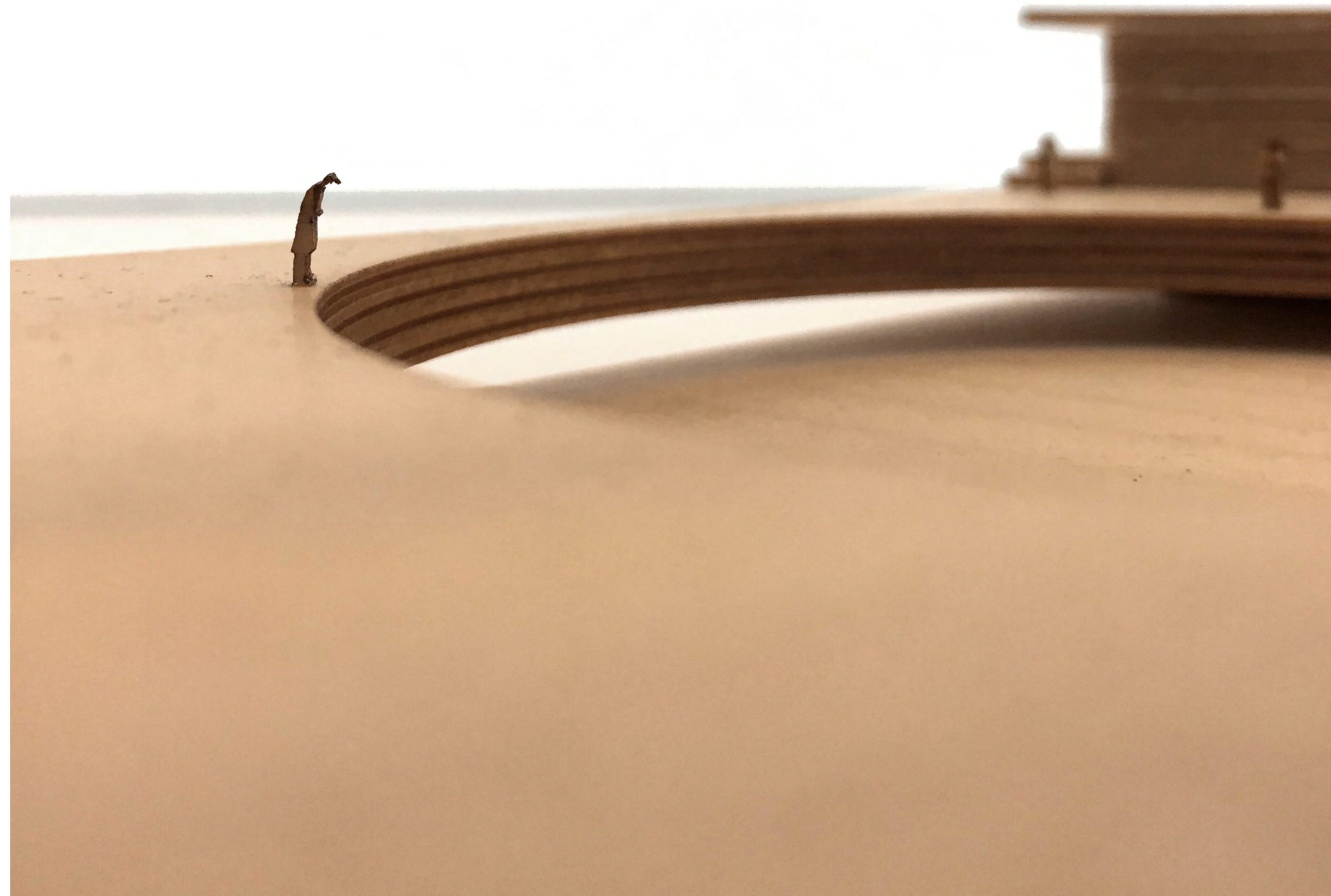

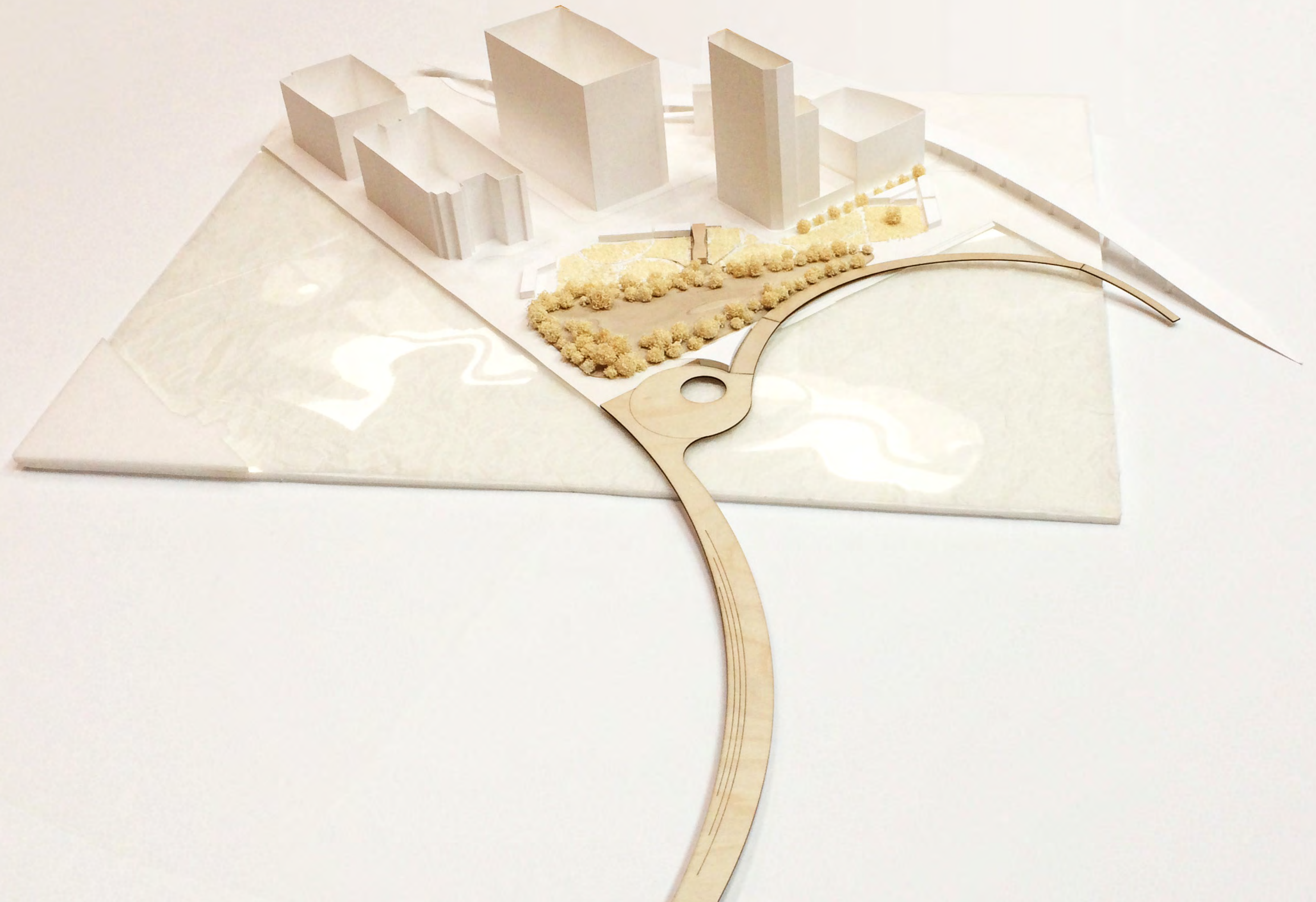

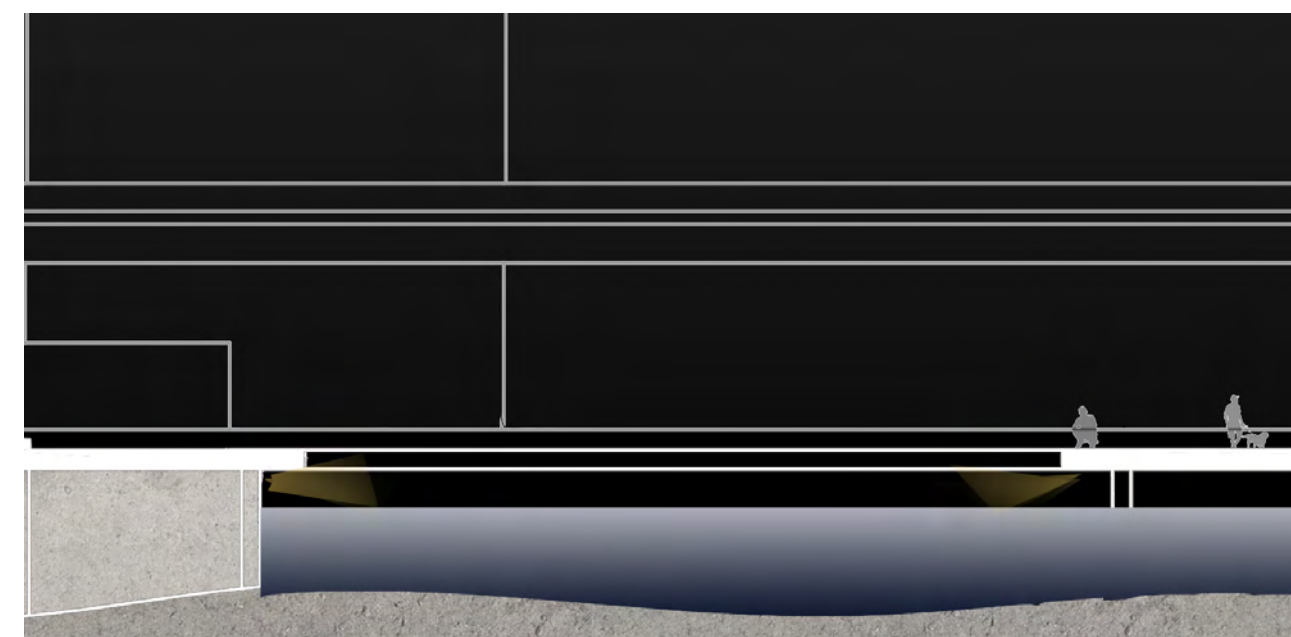
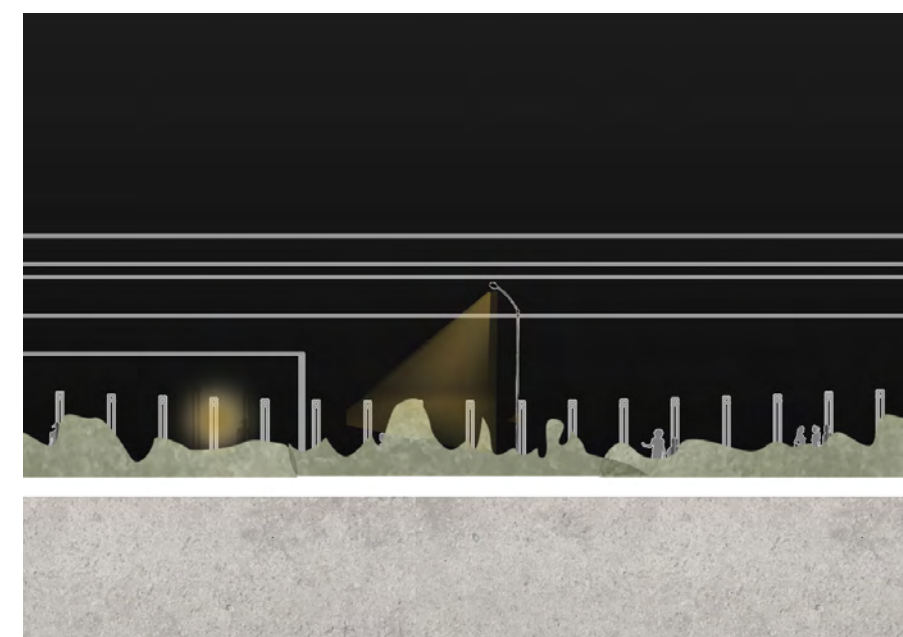
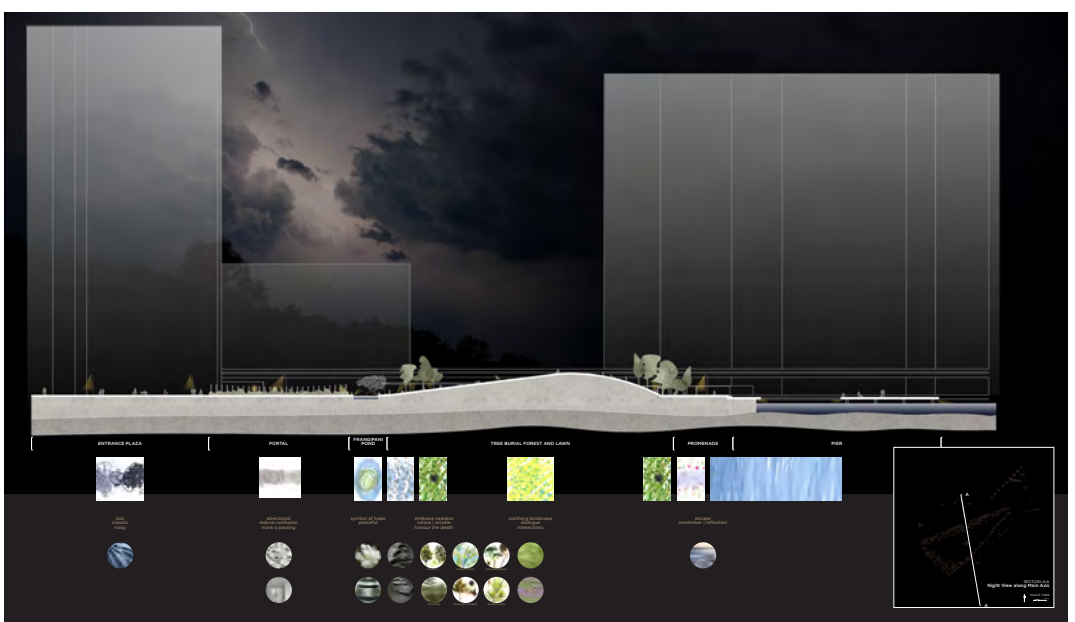
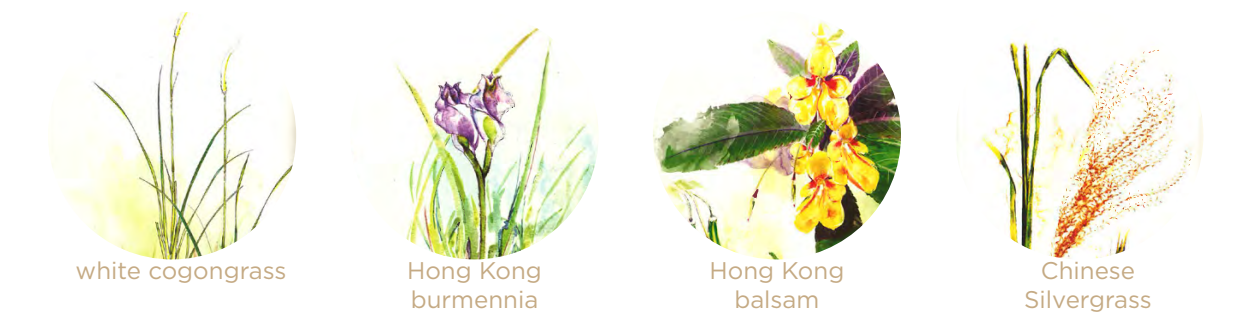
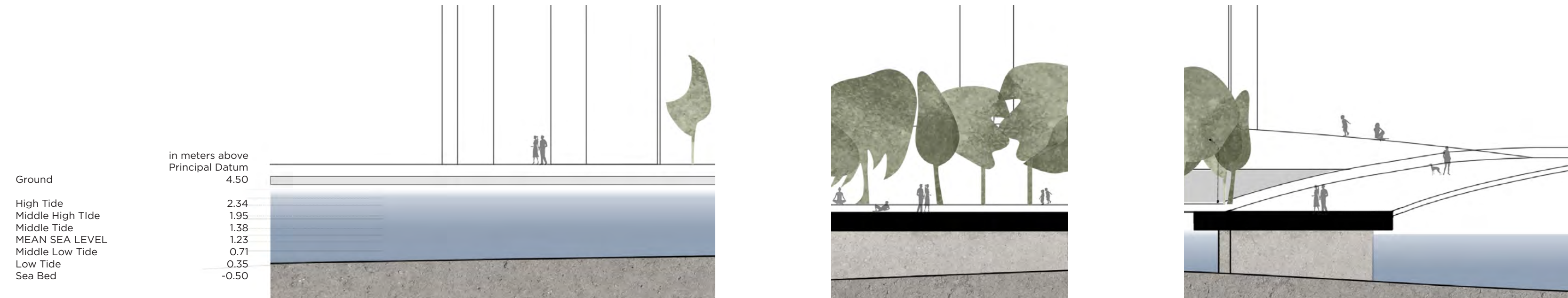
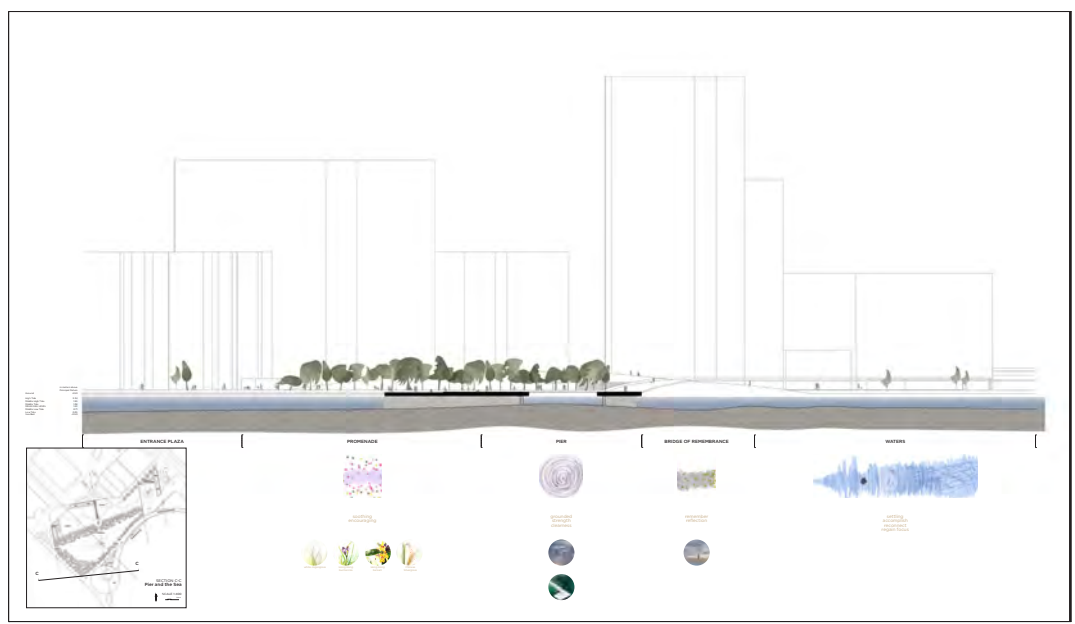
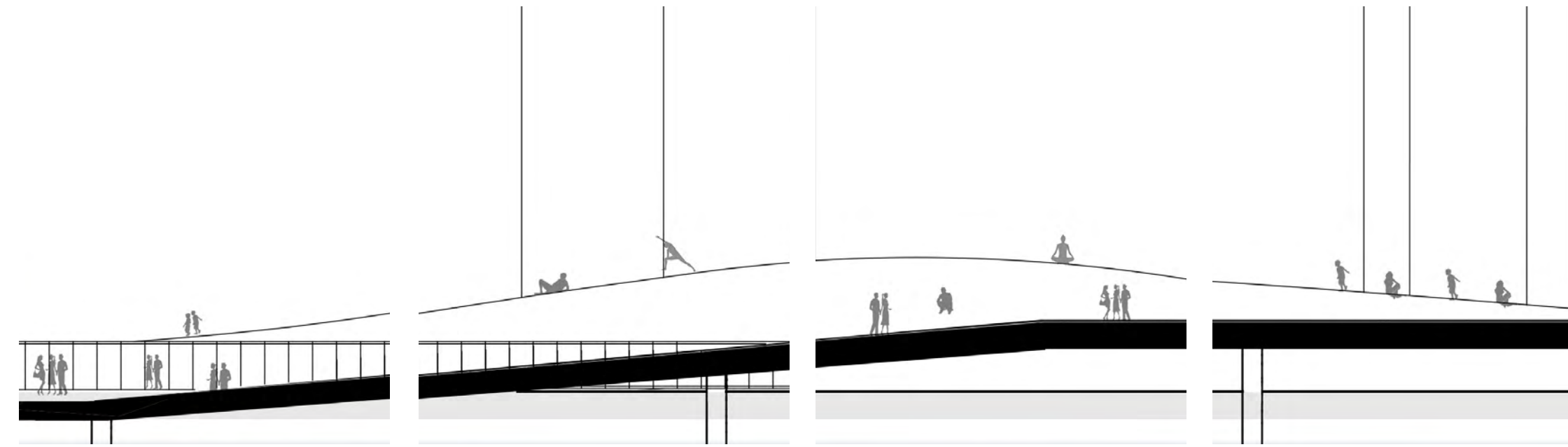
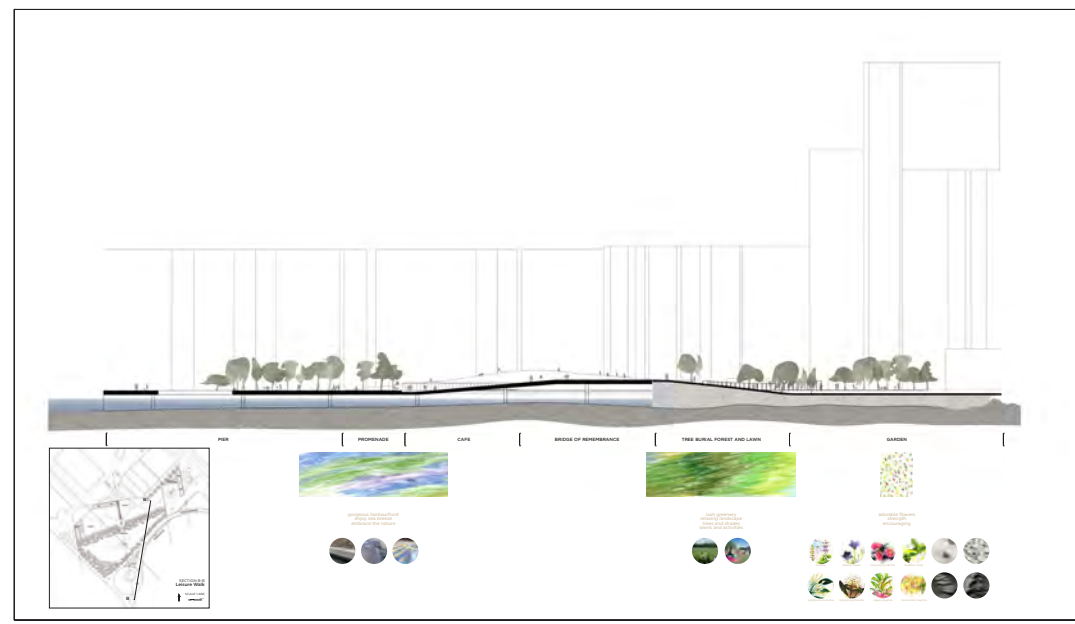

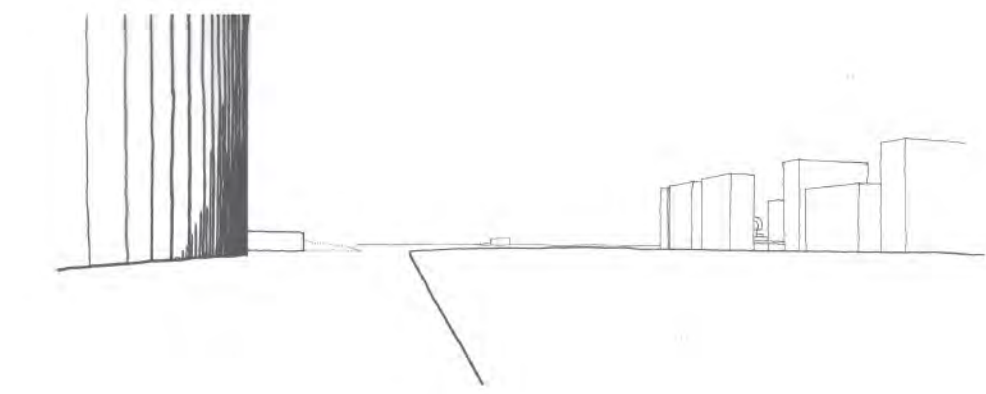
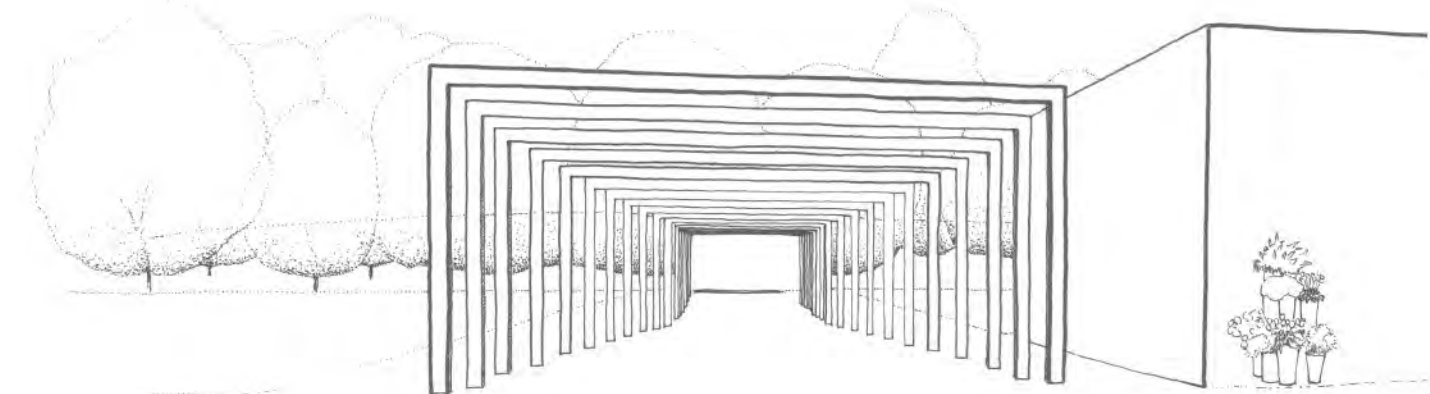
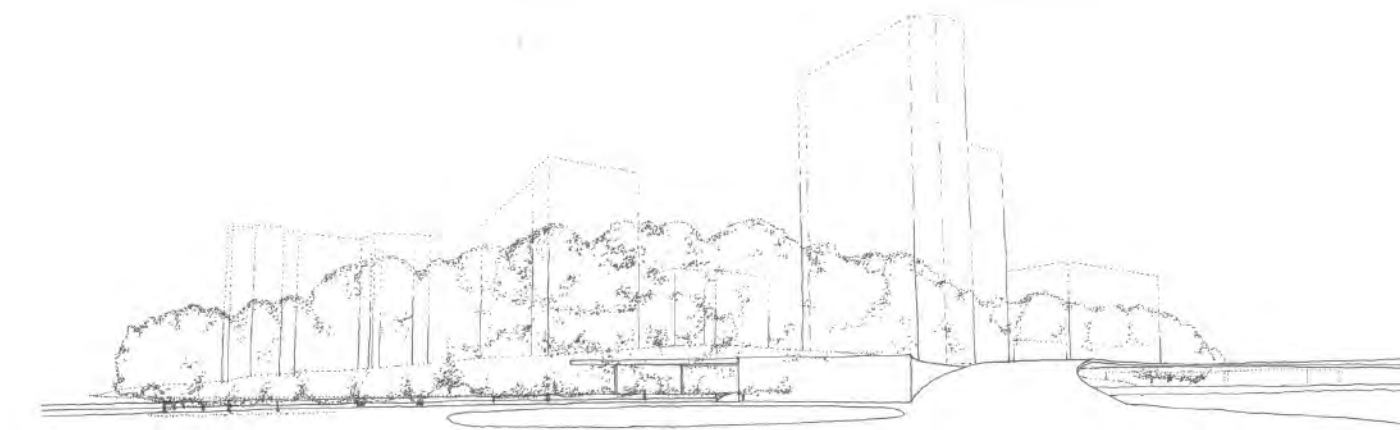
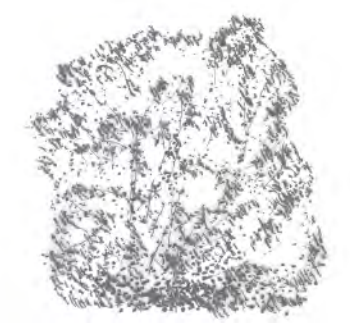
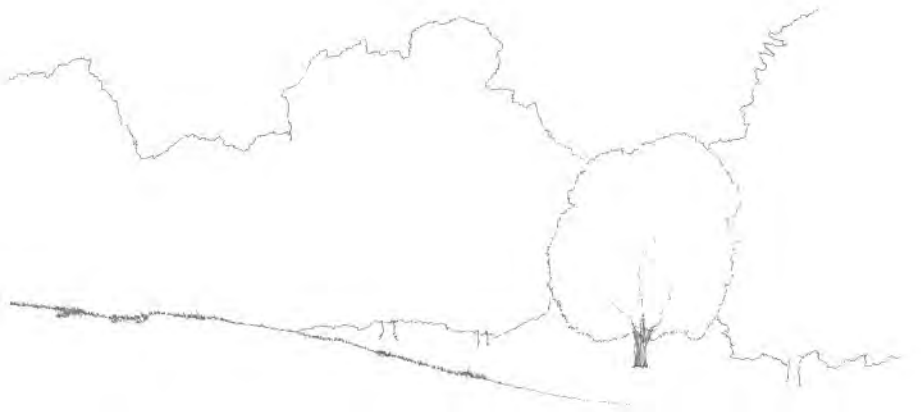
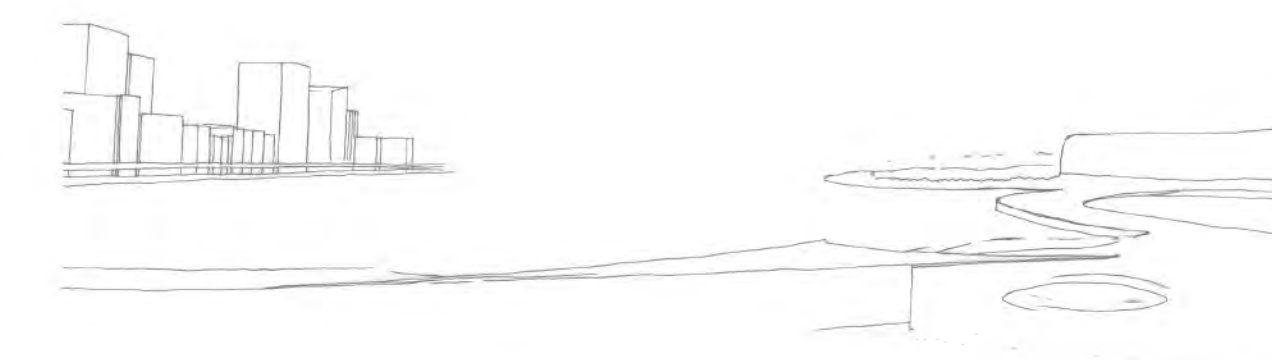
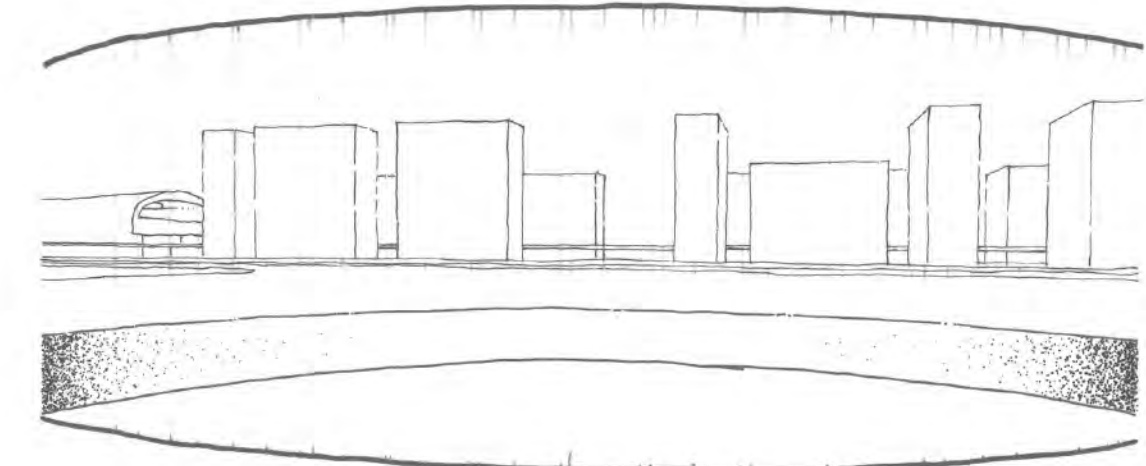
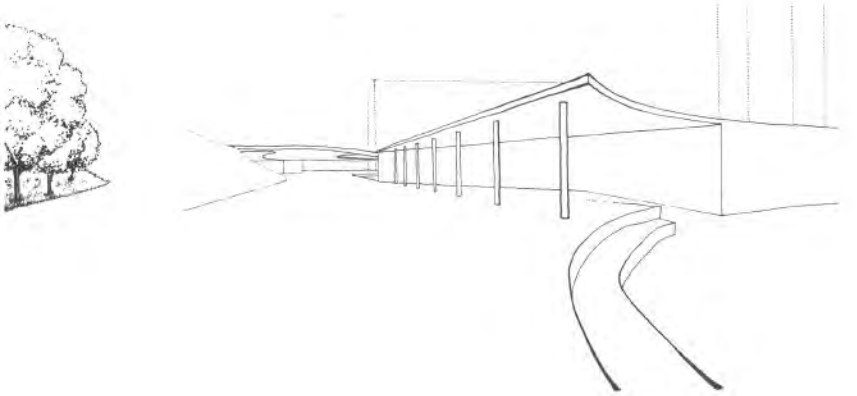
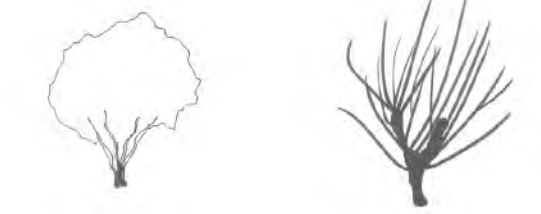
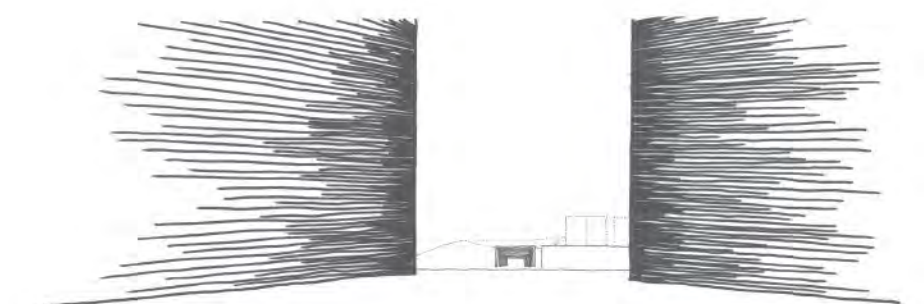
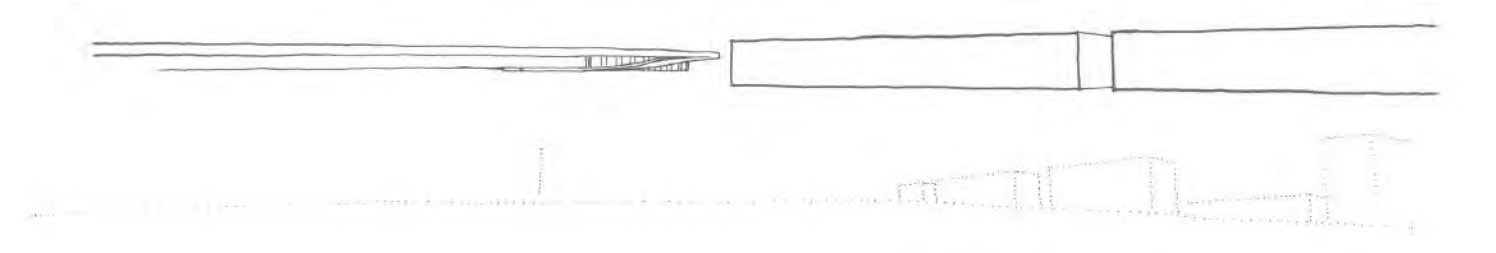
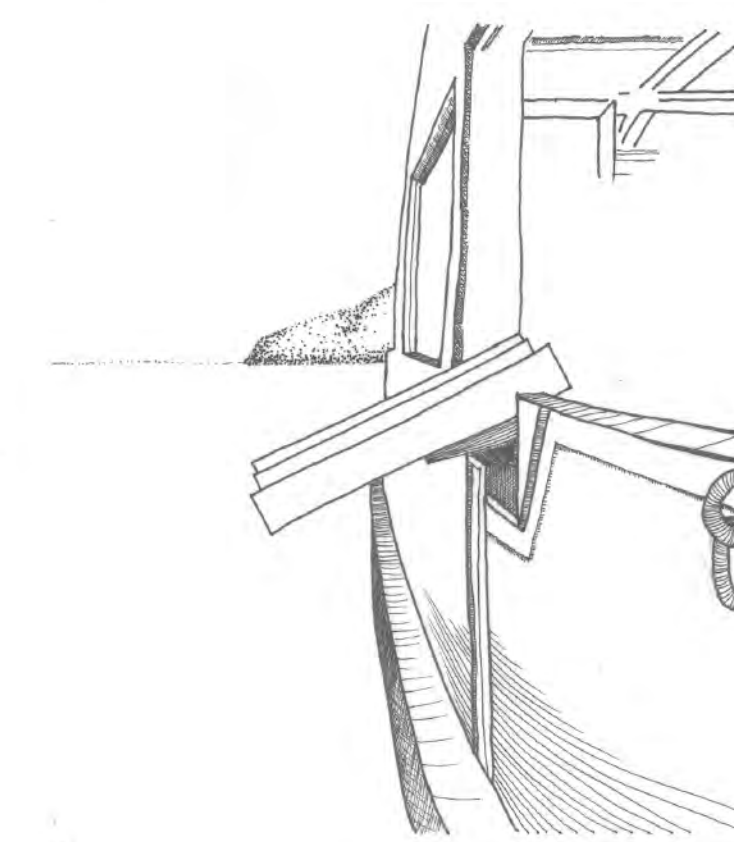
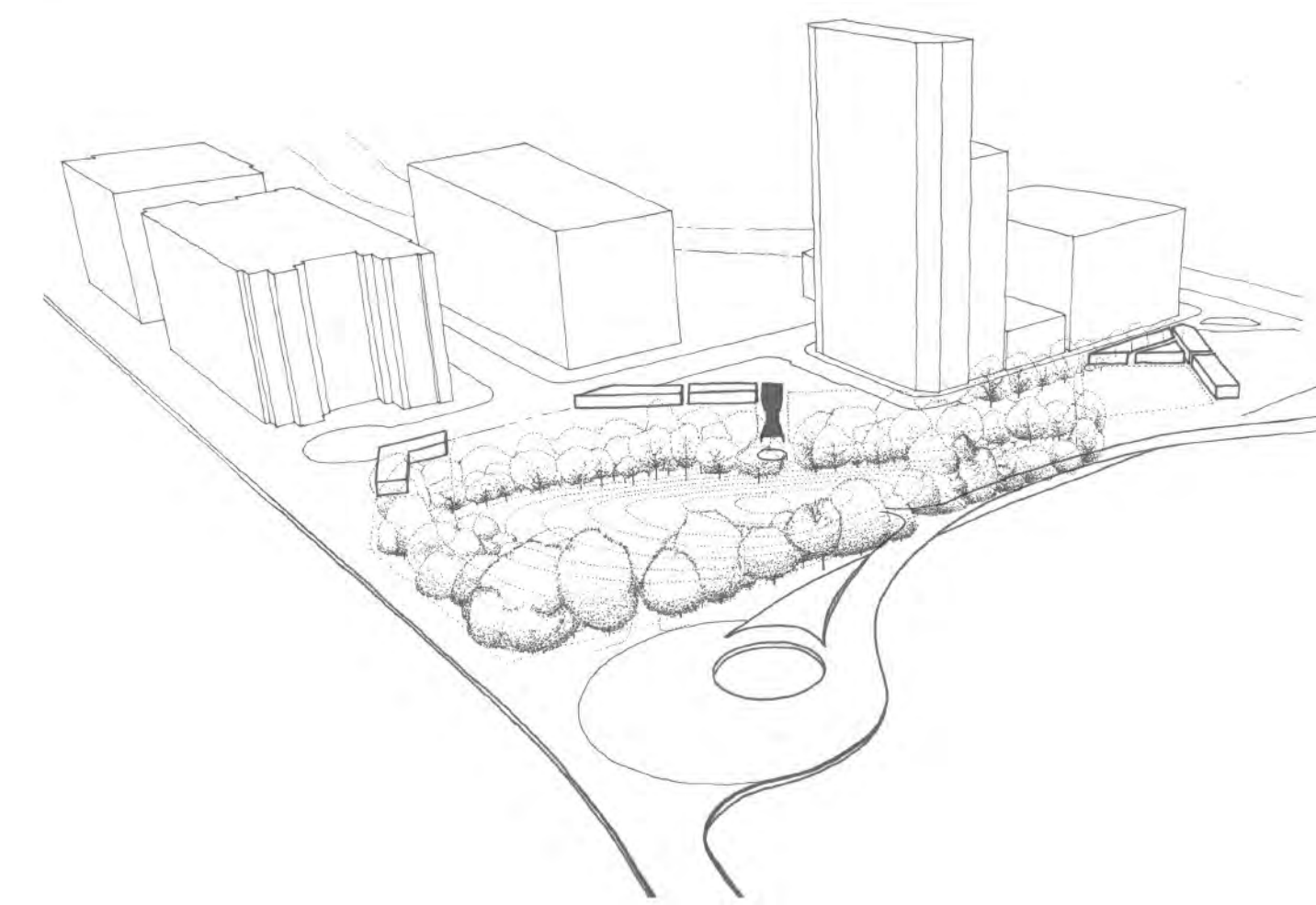
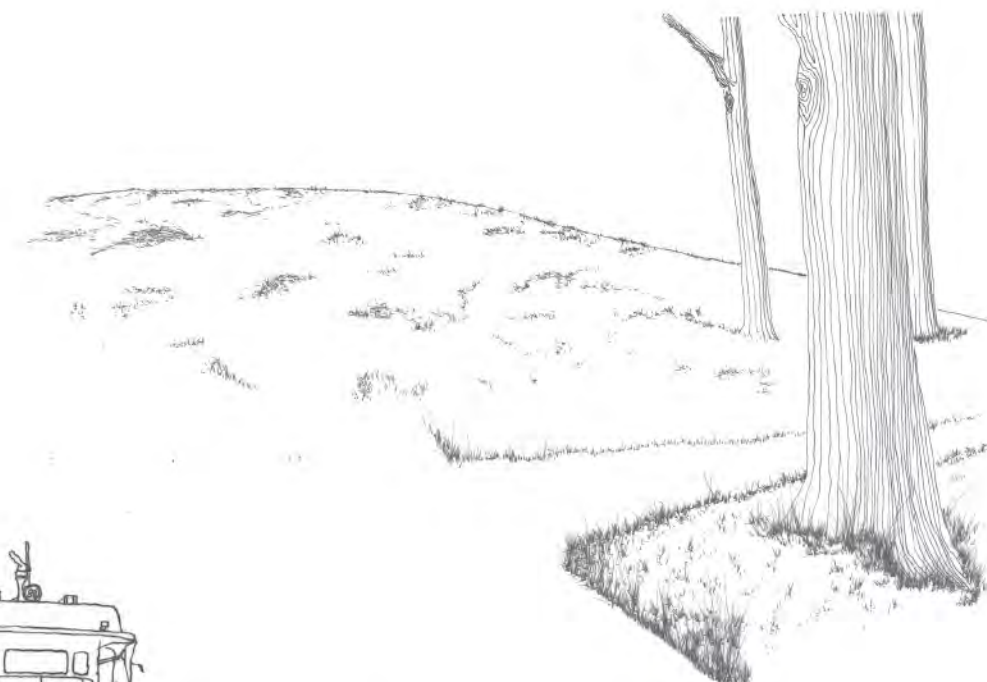
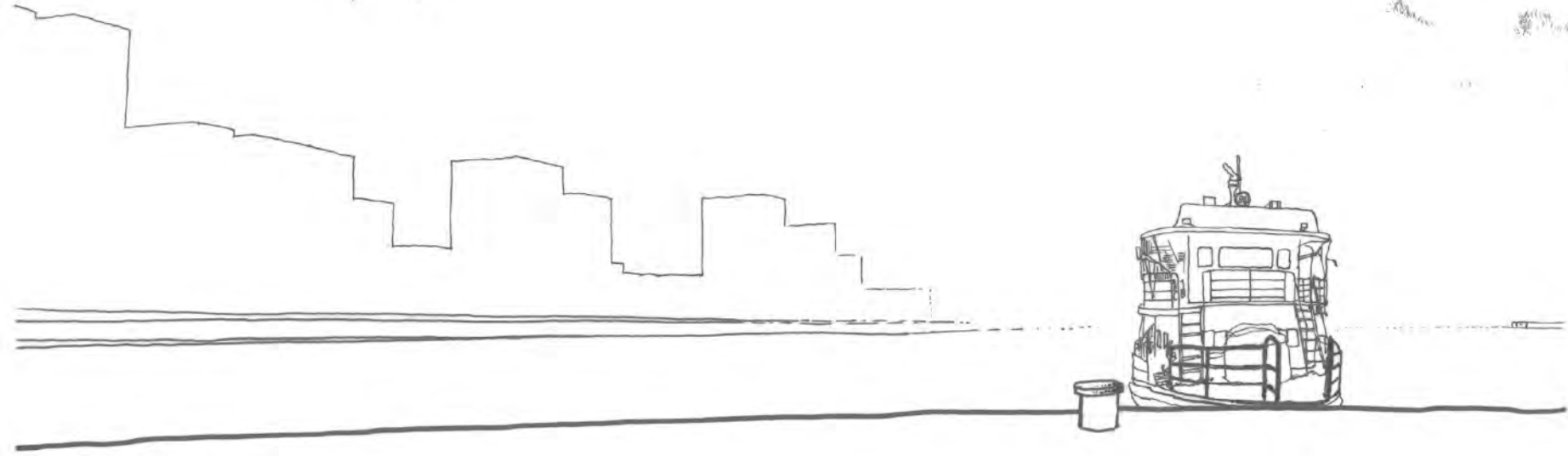
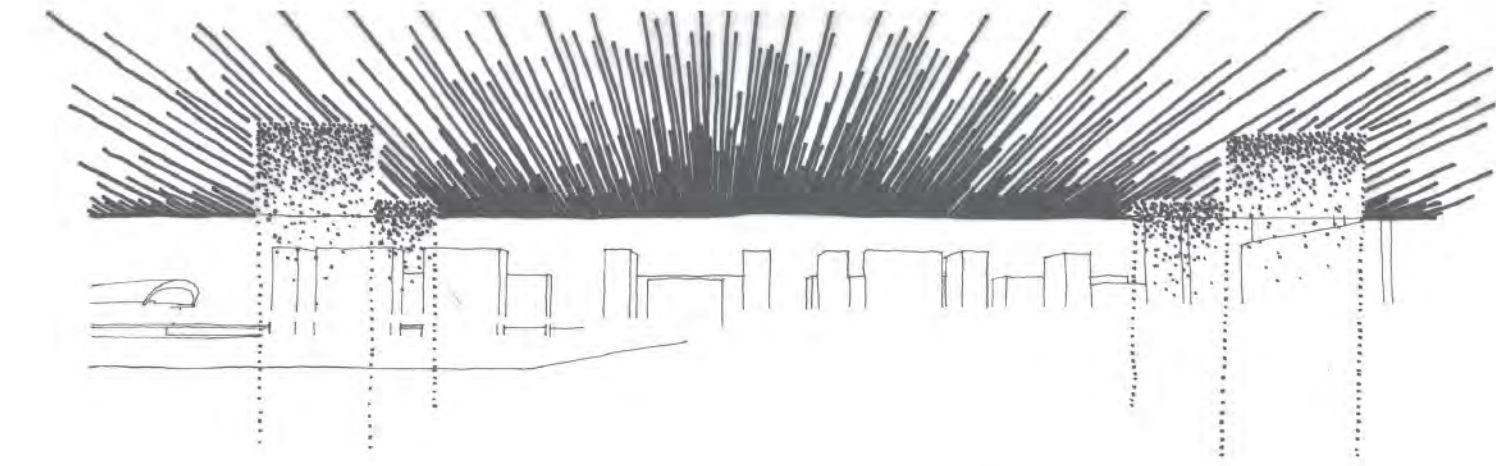
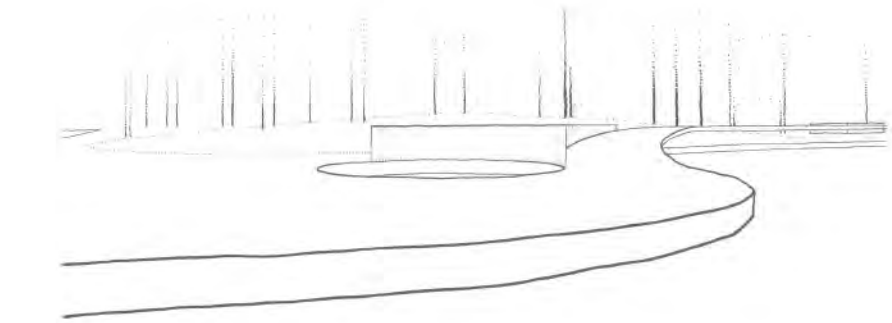
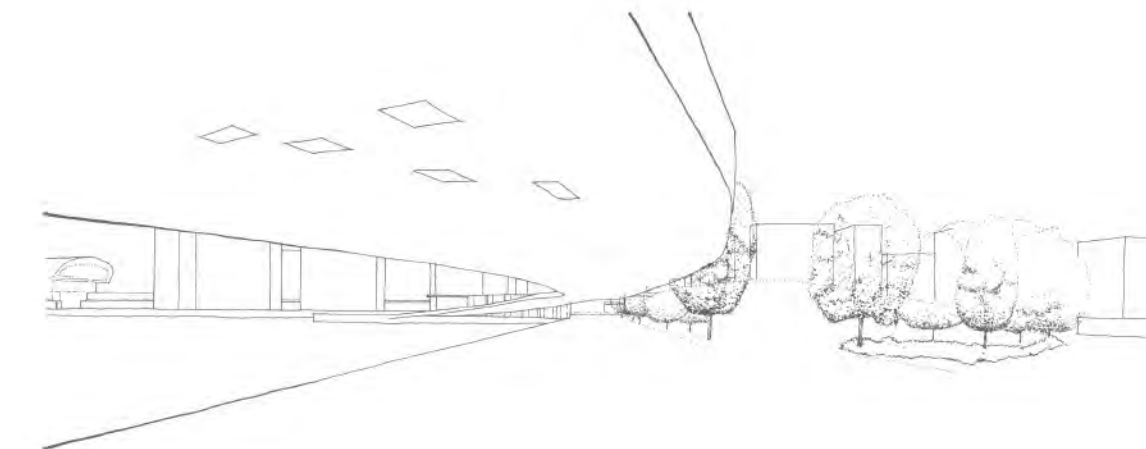



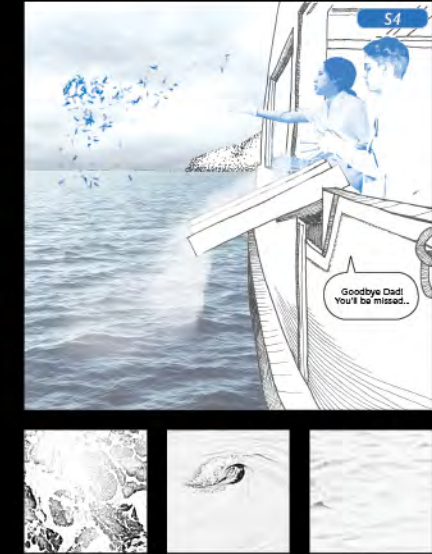
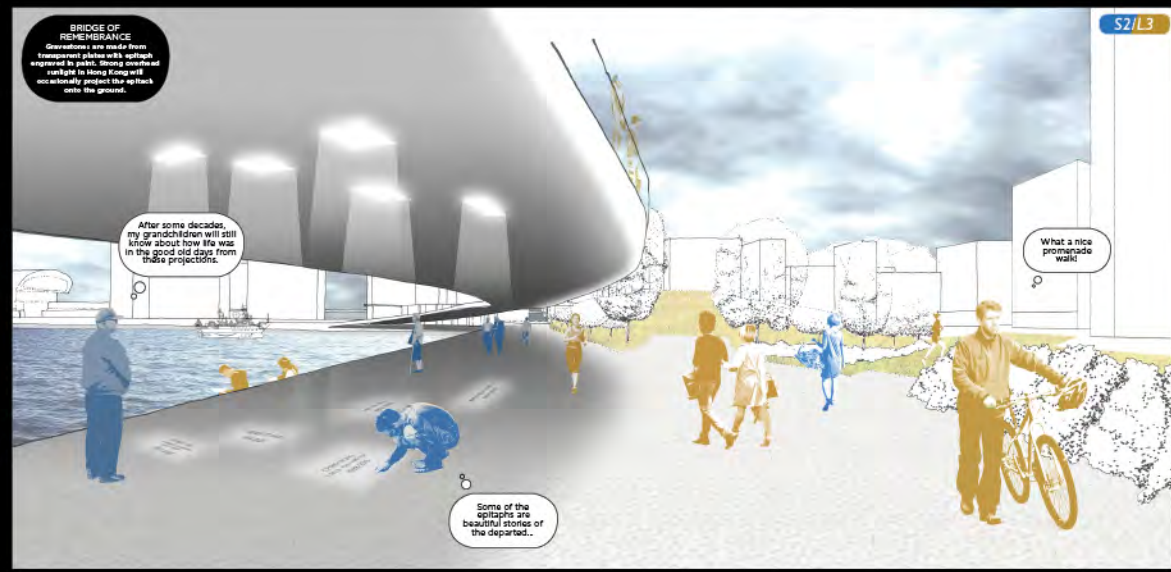
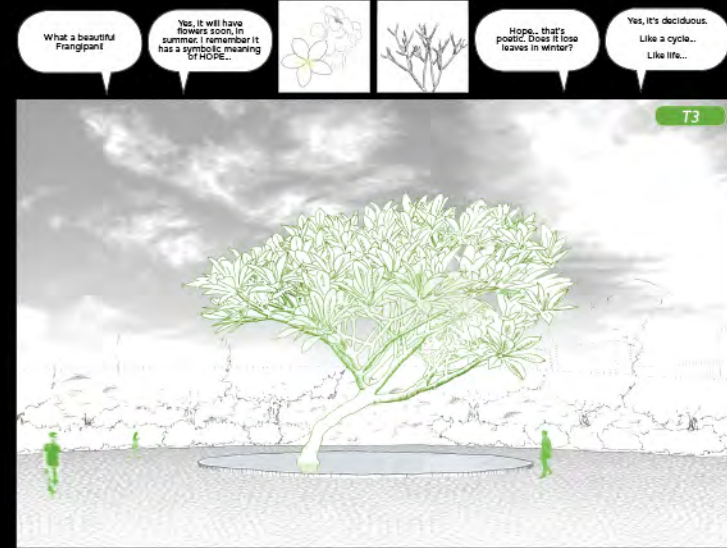
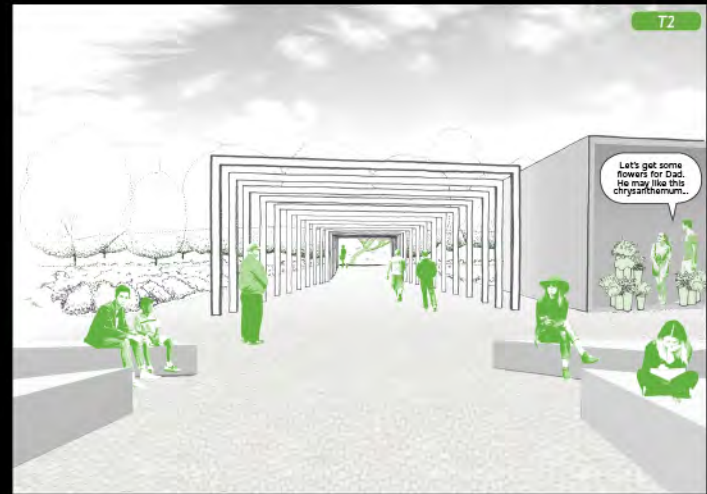
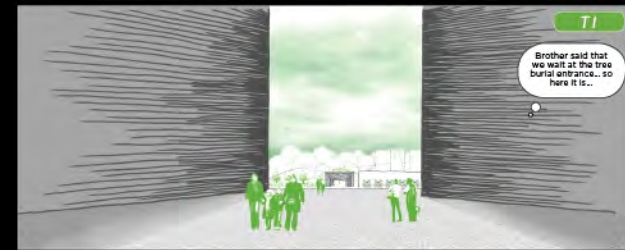

Let's get some...  
Let's get some...  
Let's get some...

Let's get some...  
Let's get some...  
Let's get some...

What a beautiful...  
This is what...  
This is what...  
This is what...  
This is what...

Let's get some...  
Let's get some...  
Let's get some...

Let's get some...  
Let's get some...  
Let's get some...

Let's get some...  
Let's get some...  
Let's get some...

Let's get some...  
Let's get some...  
Let's get some...

Let's get some...  
Let's get some...  
Let's get some...

Let's get some...  
Let's get some...  
Let's get some...

Let's get some...  
Let's get some...  
Let's get some...

Let's get some...  
Let's get some...  
Let's get some...

Let's get some...  
Let's get some...  
Let's get some...

Let's get some...  
Let's get some...  
Let's get some...

Let's get some...  
Let's get some...  
Let's get some...

Let's get some...  
Let's get some...  
Let's get some...

Let's get some...  
Let's get some...  
Let's get some...

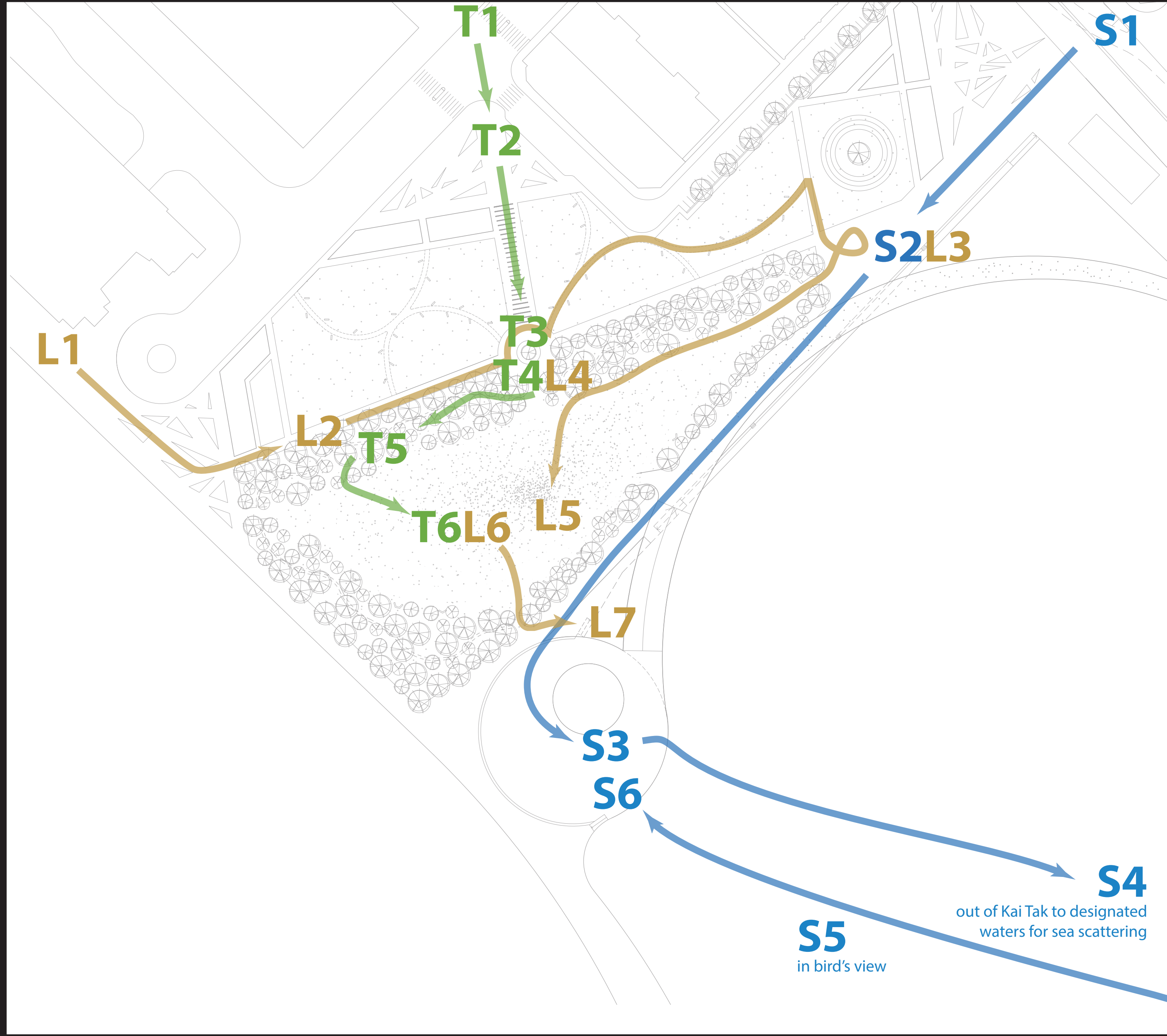

JOURNEYS OVERVIEW

- tree burial
- sea burial
- local
- intersections

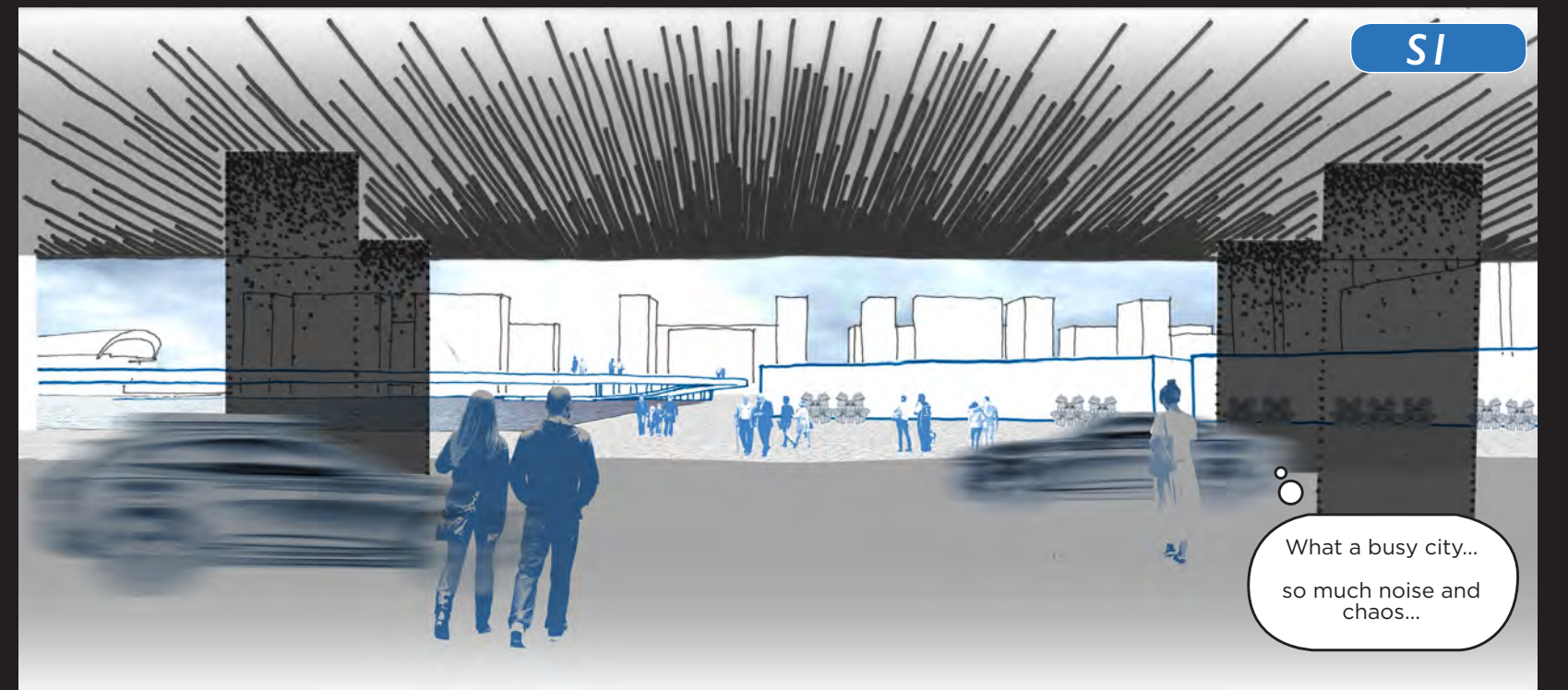
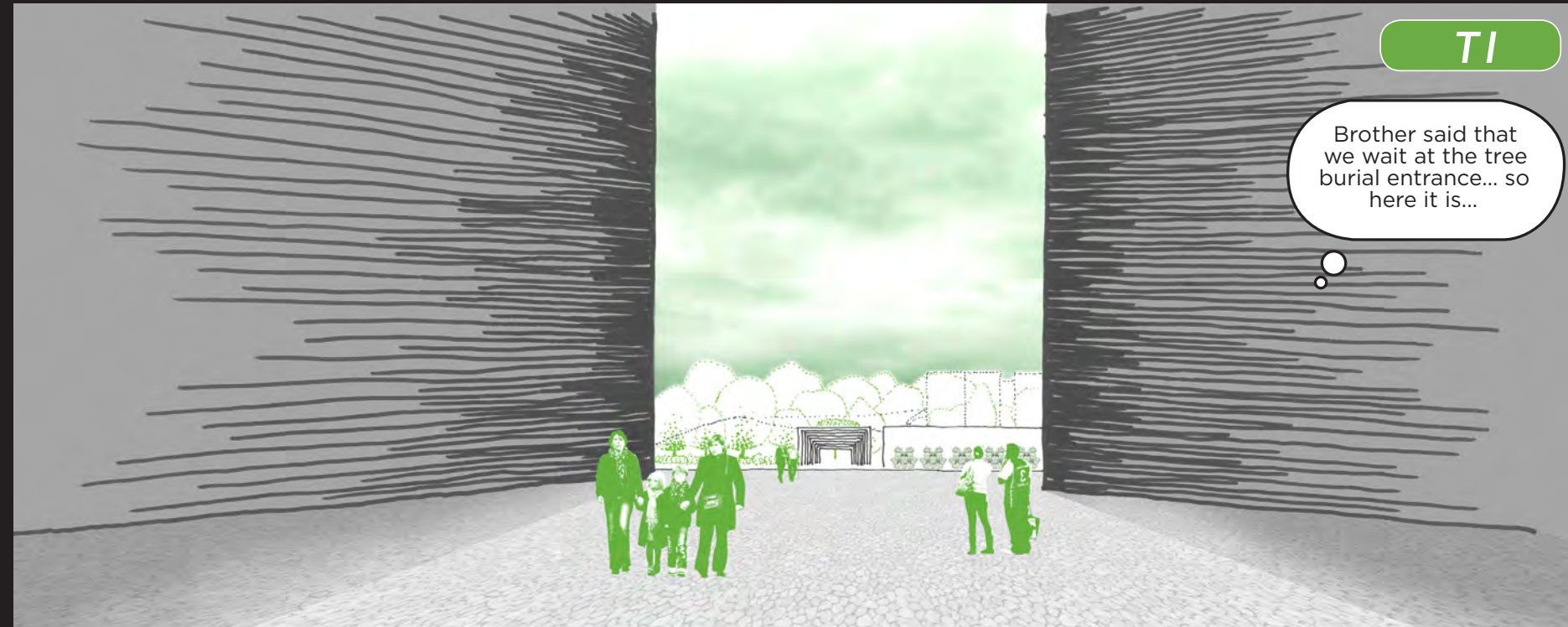

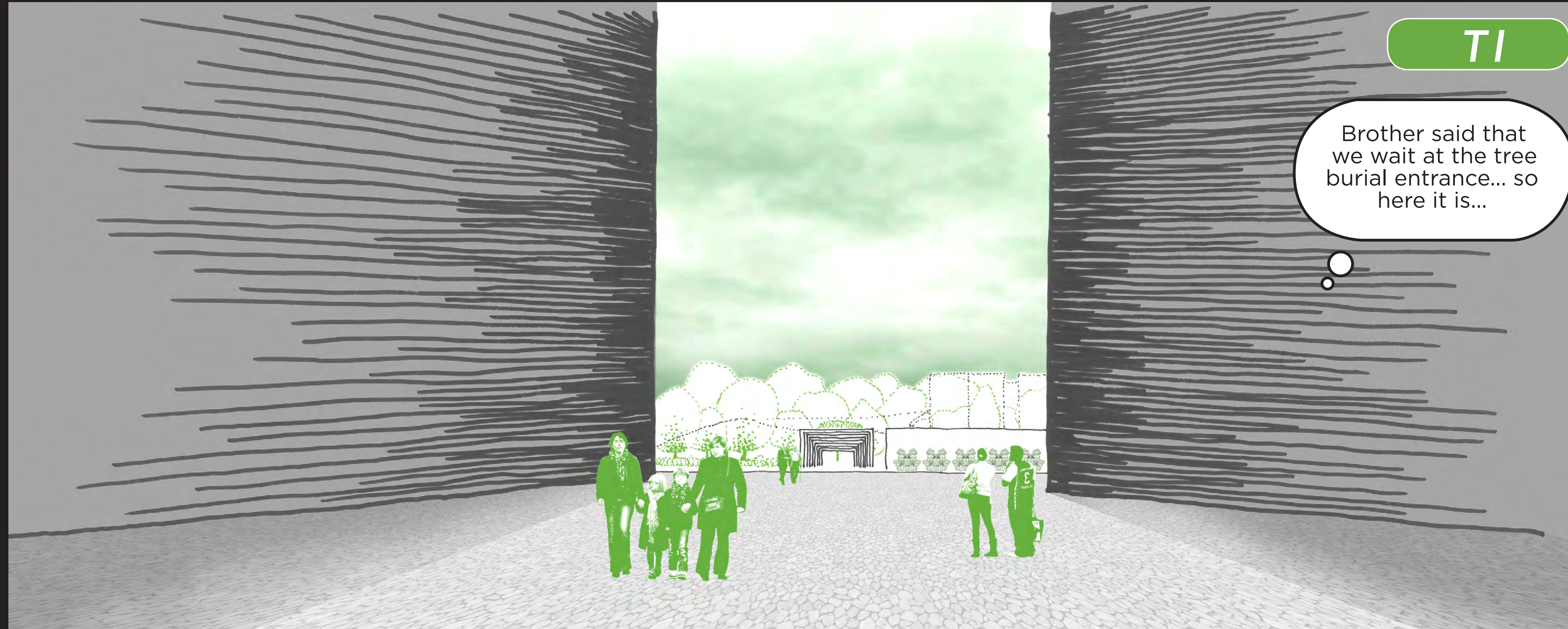

TI

Brother said that we wait at the tree burial entrance... so here it is...

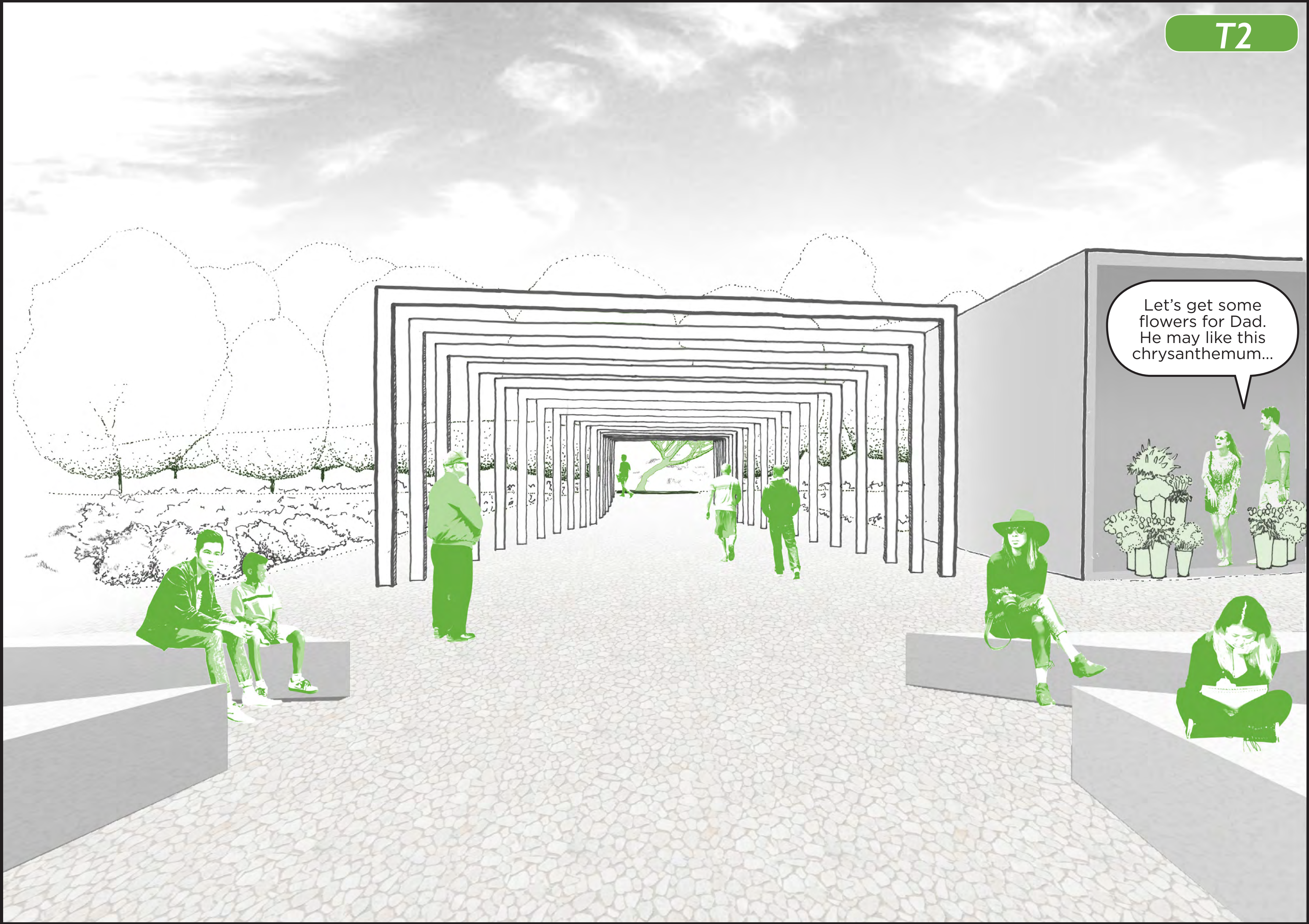

What a beautiful Frangipani!

Yes, it will have flowers soon, in summer. I remember it has a symbolic meaning of HOPE...

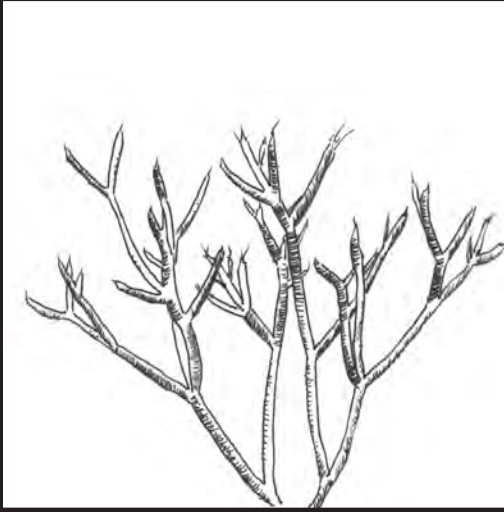
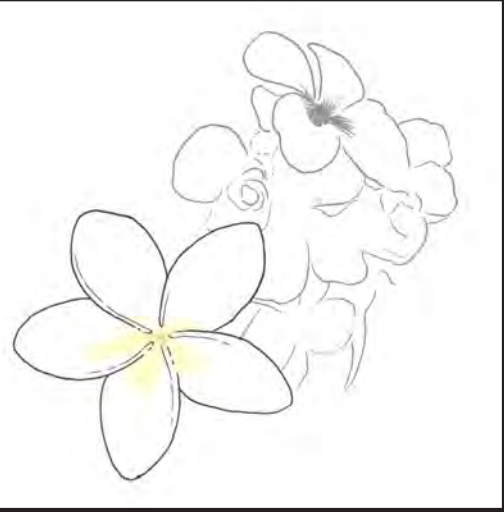

Hope... that's poetic. Does it lose leaves in winter?

Yes, it's deciduous.  
Like a cycle...  
Like life...

T3





So this is where father's ashes will stay.

Yes. Nice to return to nature.



**TREE BURIAL**  
Cremated ashes are sent to the roots of the trees through pre-cast tubes embedded around the designated trees. Cover plates of the tubes are marked with index numbers.

Goodbye Dad...



I couldn't imagine we can bring our dog to a "cemetery".

Yes, because the ashes are deep in the soil. Nothing can be dugged out. This makes the park 24-7 too.

What do you prefer, sit under tree shade or lie down, or keep walking?

I don't know... Maybe it's good to lie down here... together with other people.

How do you find this park? I told you it doesn't look like a cemetery. See?

Yes, it's just like a park. Any park. No scary dark corners, unlike traditional columbariums...



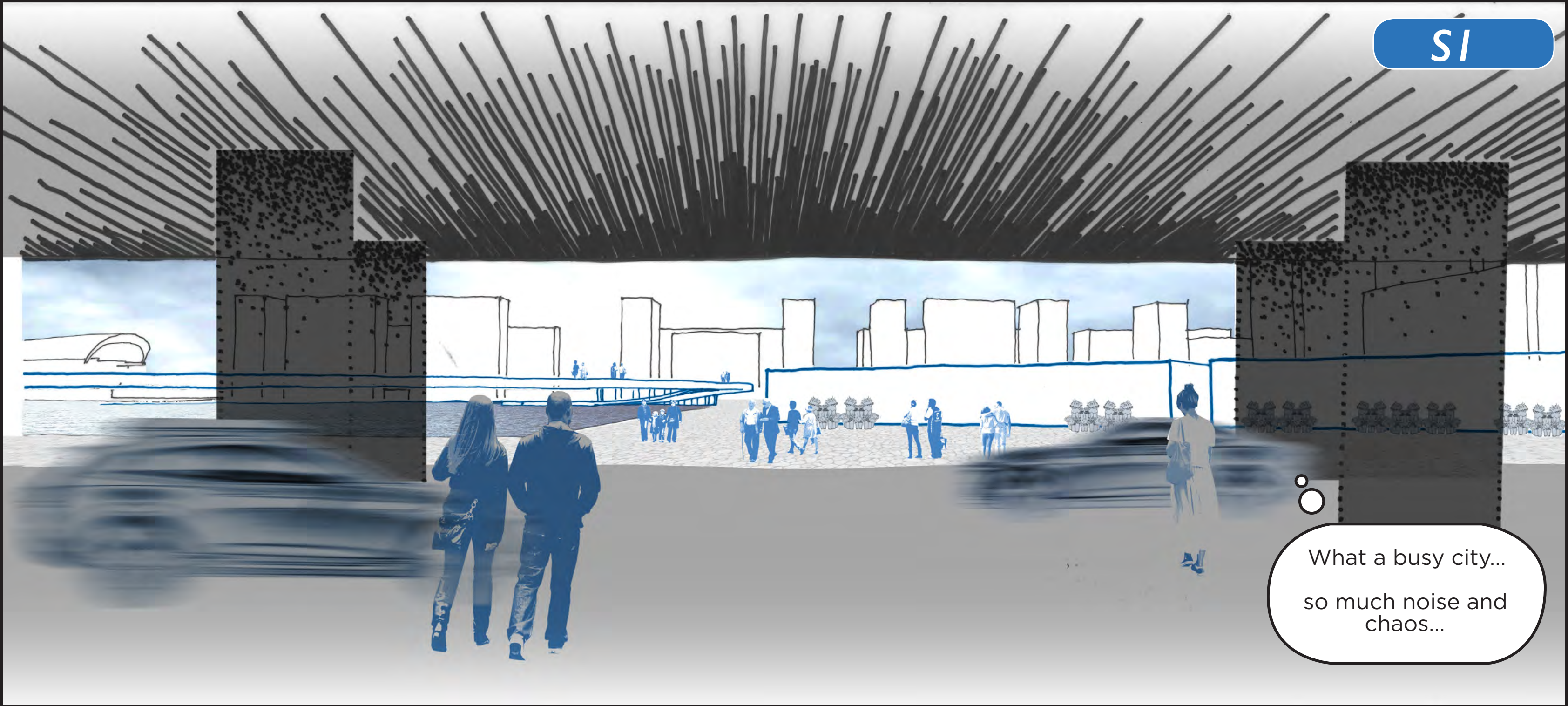

SI

What a busy city...  
so much noise and  
chaos...

**BRIDGE OF REMEMBRANCE**  
Gravestones are made from transparent plates with epitaph engraved in paint. Strong overhead sunlight in Hong Kong will occasionally project the epitaph onto the ground.

After some decades, my grandchildren will still know about how life was in the good old days from these projections.

What a nice promenade walk!

Some of the epitaphs are beautiful stories of the departed...

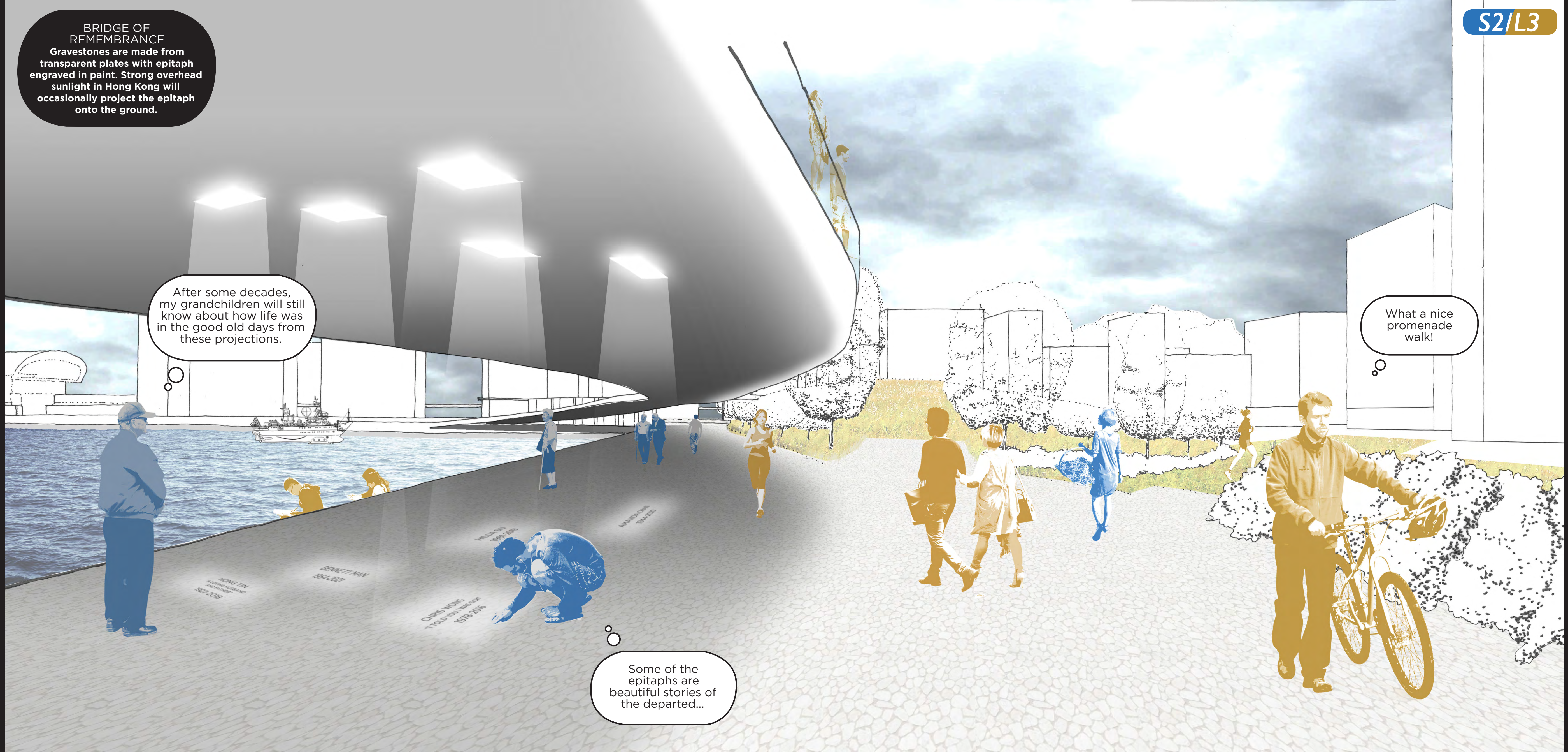

**SEA BURIAL**  
Ferries take mourners to the outskirts of Hong Kong, where the cremated ashes are scattered at designated seas.



S4

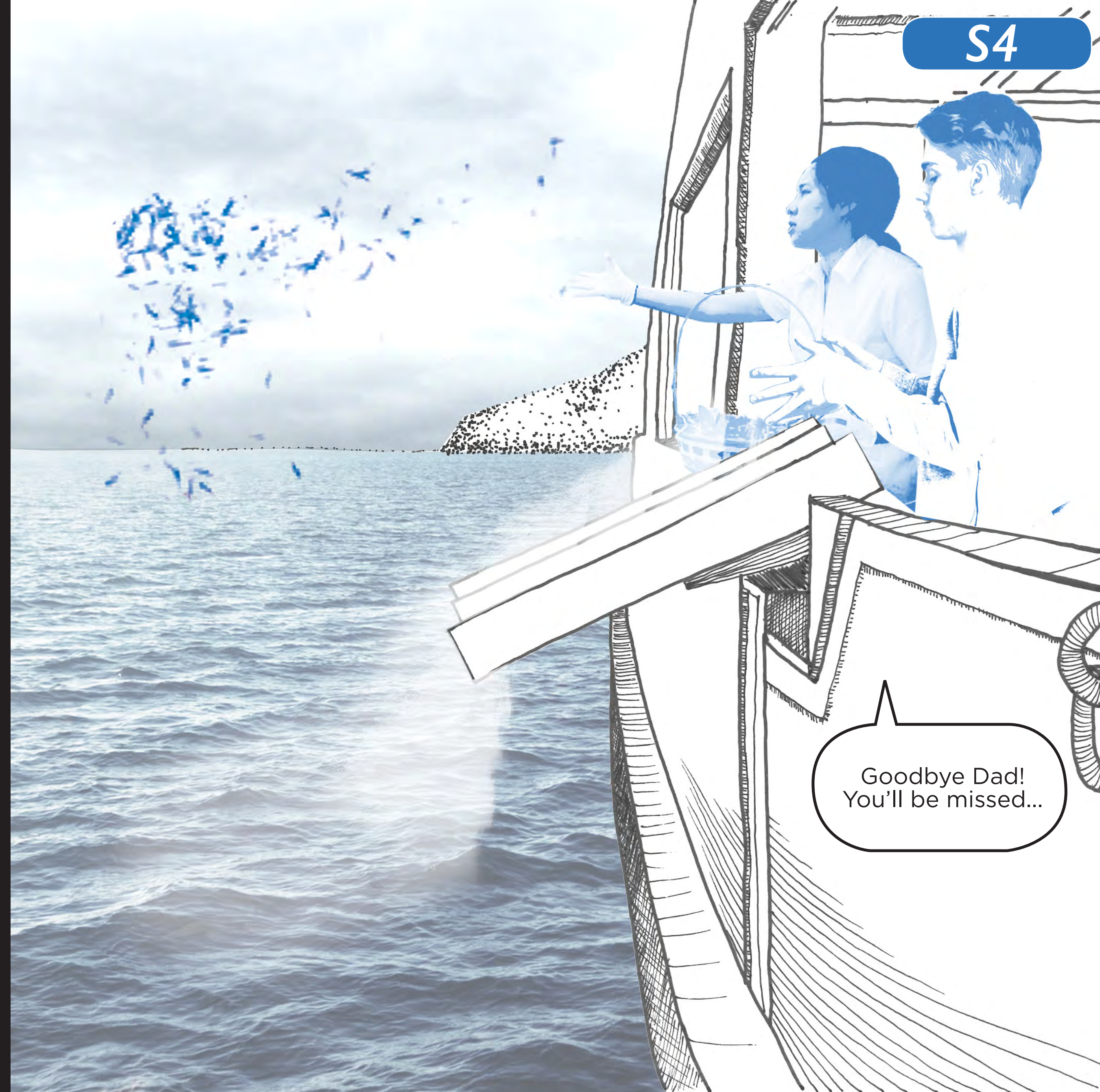

Goodbye Dad!  
You'll be missed...



It's a cemetery over there! Let's walk another route.

Hey why do we make a turn here?

Really?! Not scary? um... ok, let's have a look.

No no... it looks purely like a park. Don't panic.

Did you bring packed lunch today? Fancy a "picnic"?

In the cemetery-park? Haha. Why not?

Finally we have a continuous promenade!

Yeah :) No need to jog between industrial buildings.

Hey do you know that is both a cemetery and a park?

Yes... a typical example of multi-purpose use in this tiny city!

Oh... We are late. The water taxi has left!

Nevermind. Let's sit down for a cup of tea or coffee.



Let's walk along the promenade. Which way do you want to go, ground or up on the bridge?

Um, shall we sit down over there for a while?

Oh what a sudden rain!

Good to have a shelter here.

Yea... It's always rainy in Ching Ming Festival... Spring shower in the grave sweeping festival...





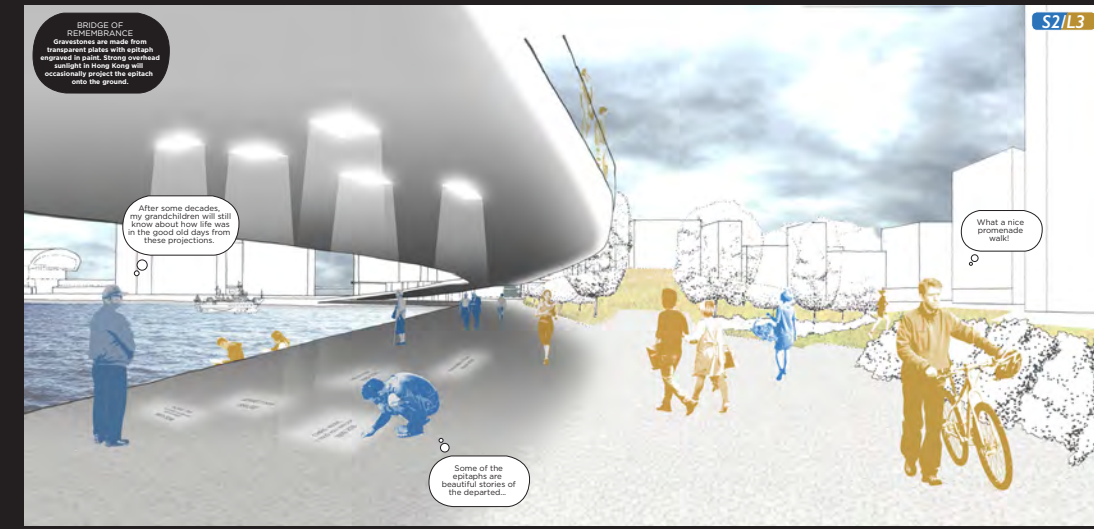
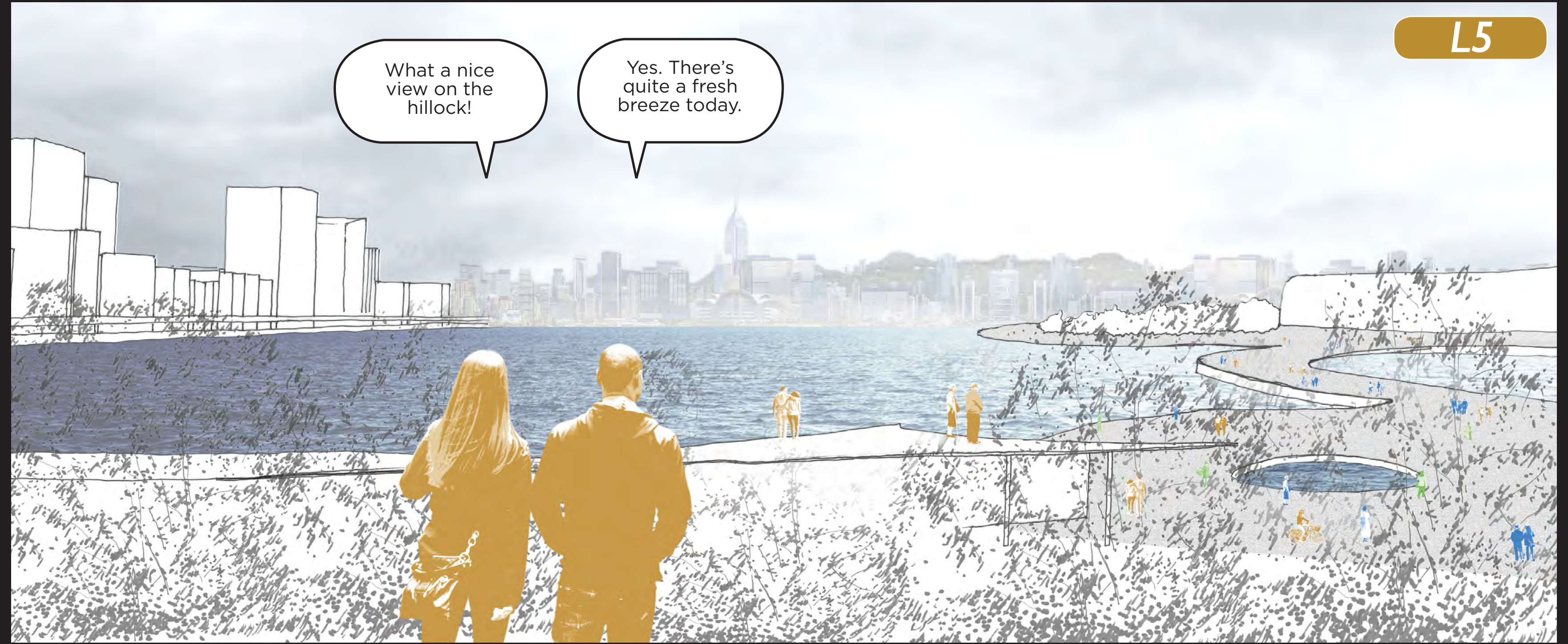



PROJECT VISION

life

death

east

west

intimate resting forest

park of openness

mourners

locals

notable burials

memories of an era

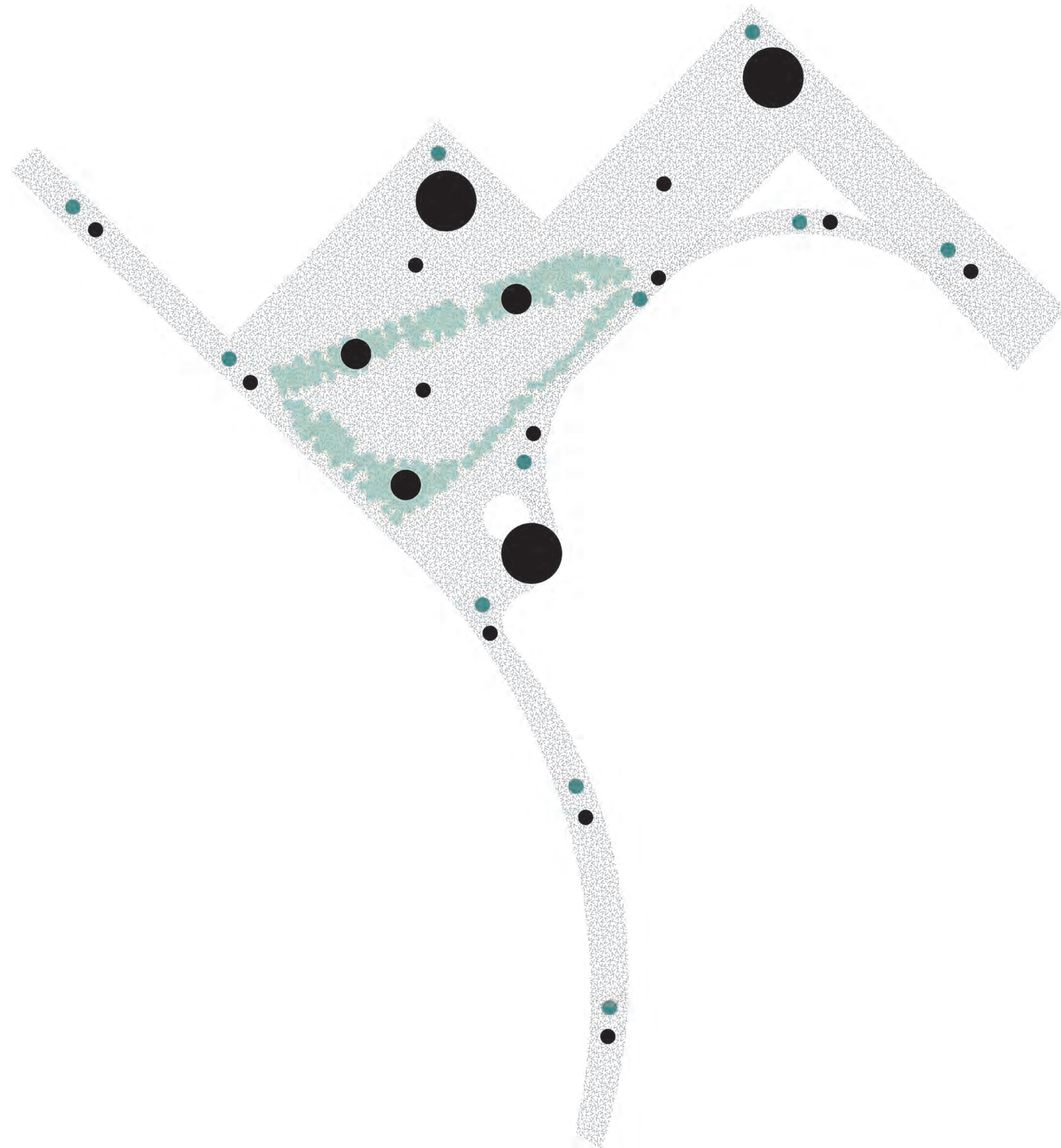

**Year 0**

**the first  
cemetery-park in  
hong kong**

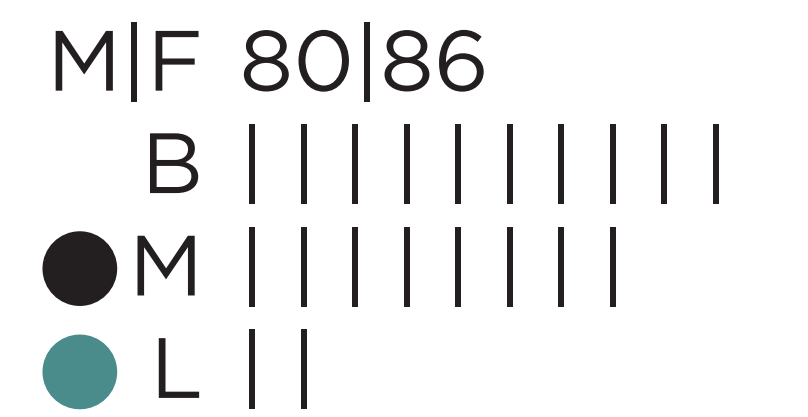

M|F Life expectancy [Male|Female]  
 B Burial  
 M Mourners  
 L Locals  
 E Education

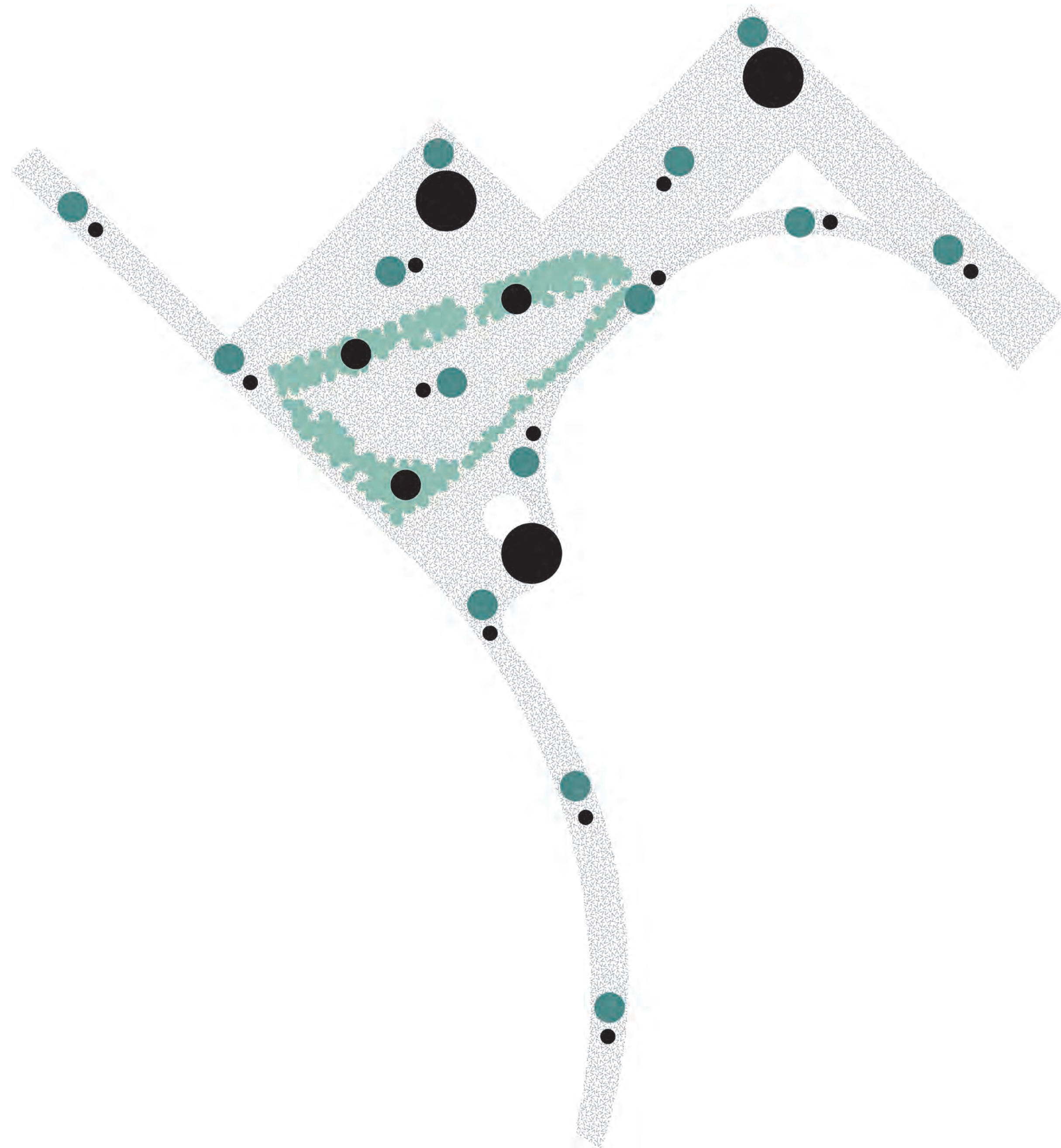

**Year 10**

**public  
acceptance**



M|F Life expectancy [Male|Female]  
 B Burial  
 M Mourners  
 L Locals  
 E Education

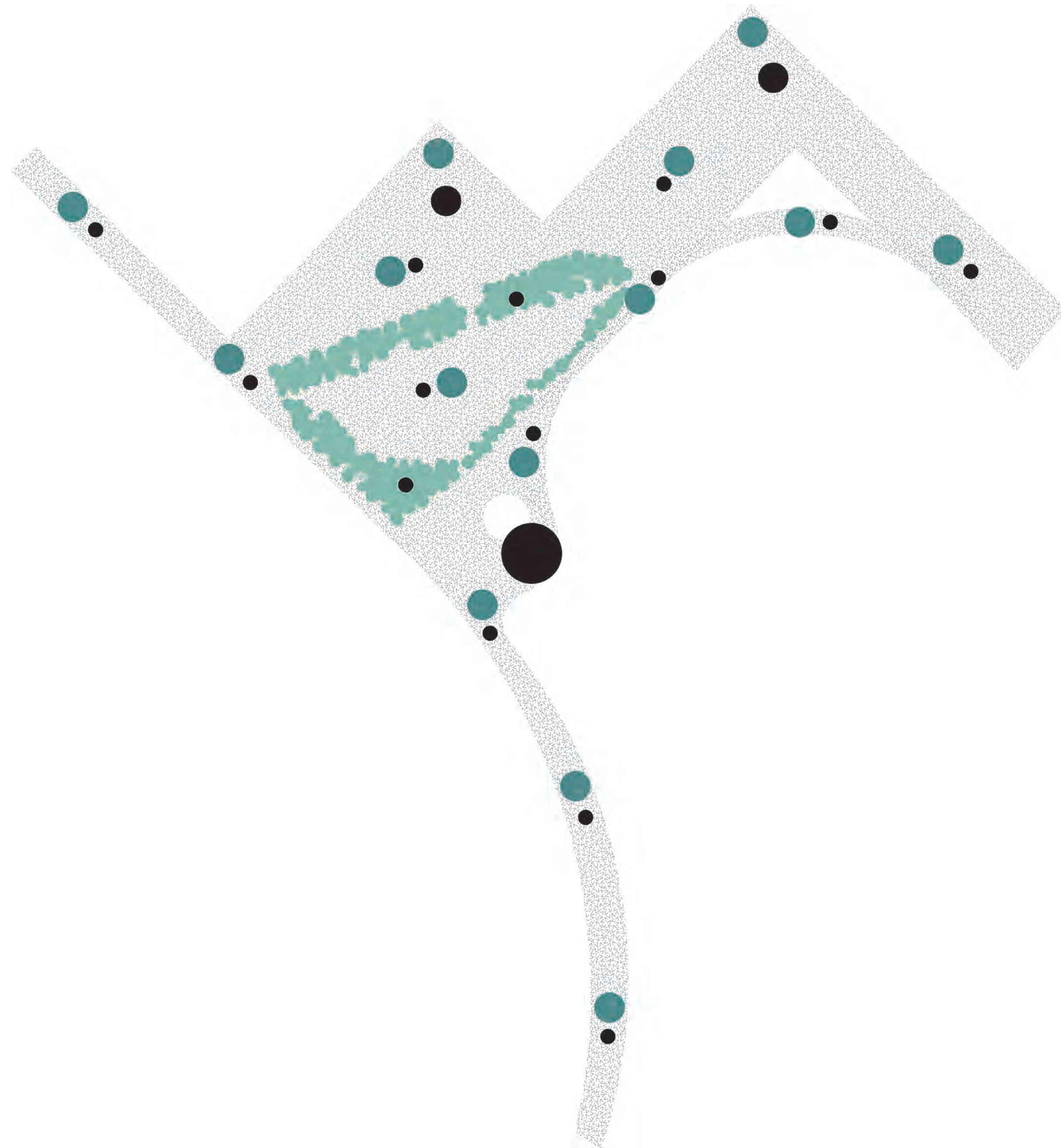

**Year 20**

**gravestones fully occupied**

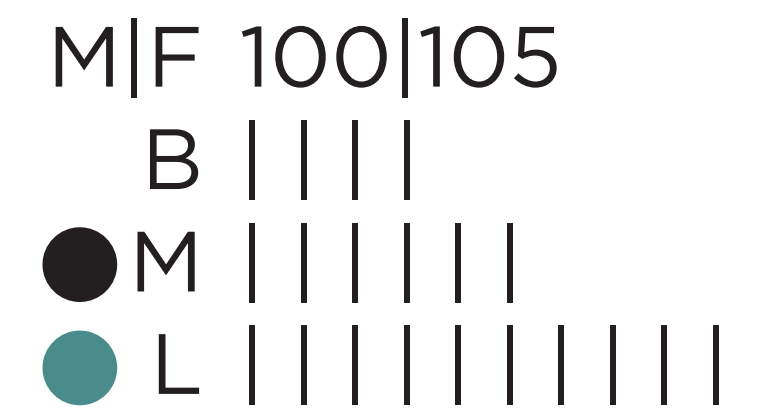

M|F Life expectancy [Male|Female]  
 B Burial  
 M Mourners  
 L Locals  
 E Education

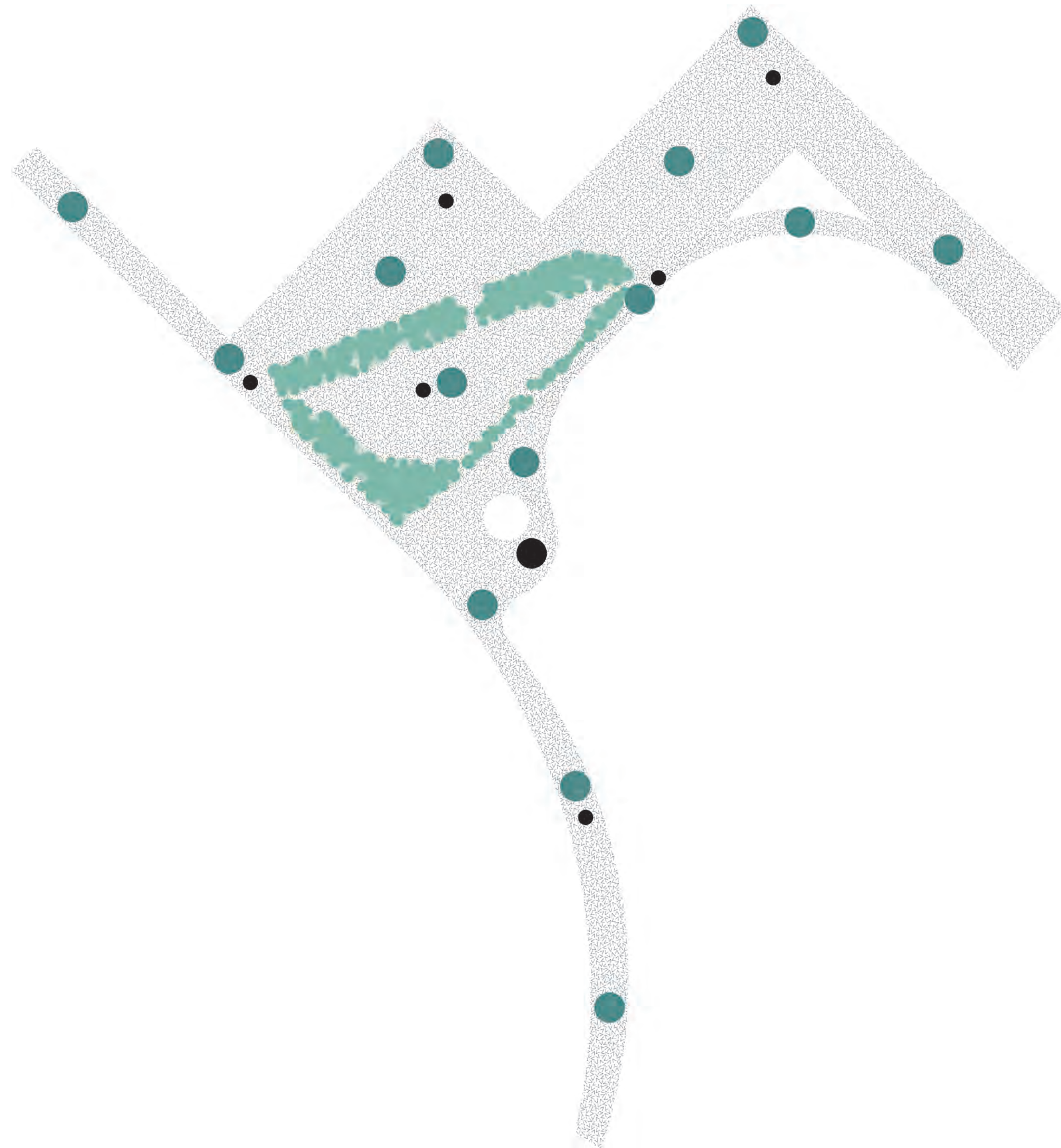

**Year 50**

**burial function  
diminishing**

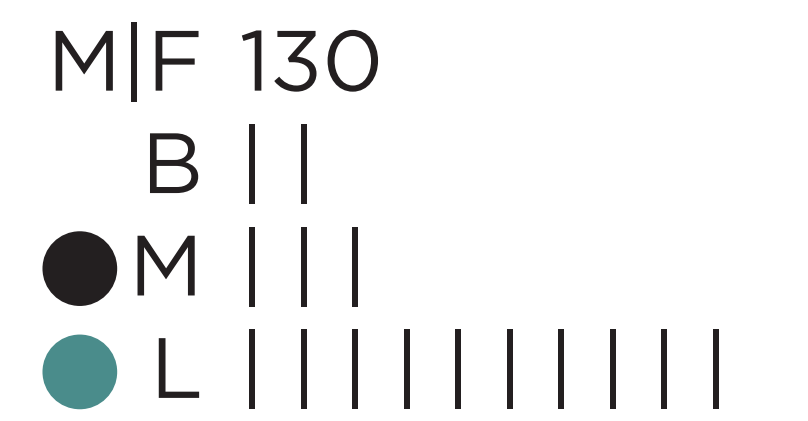

M|F Life expectancy [Male|Female]  
 B Burial  
 M Mourners  
 L Locals  
 E Education

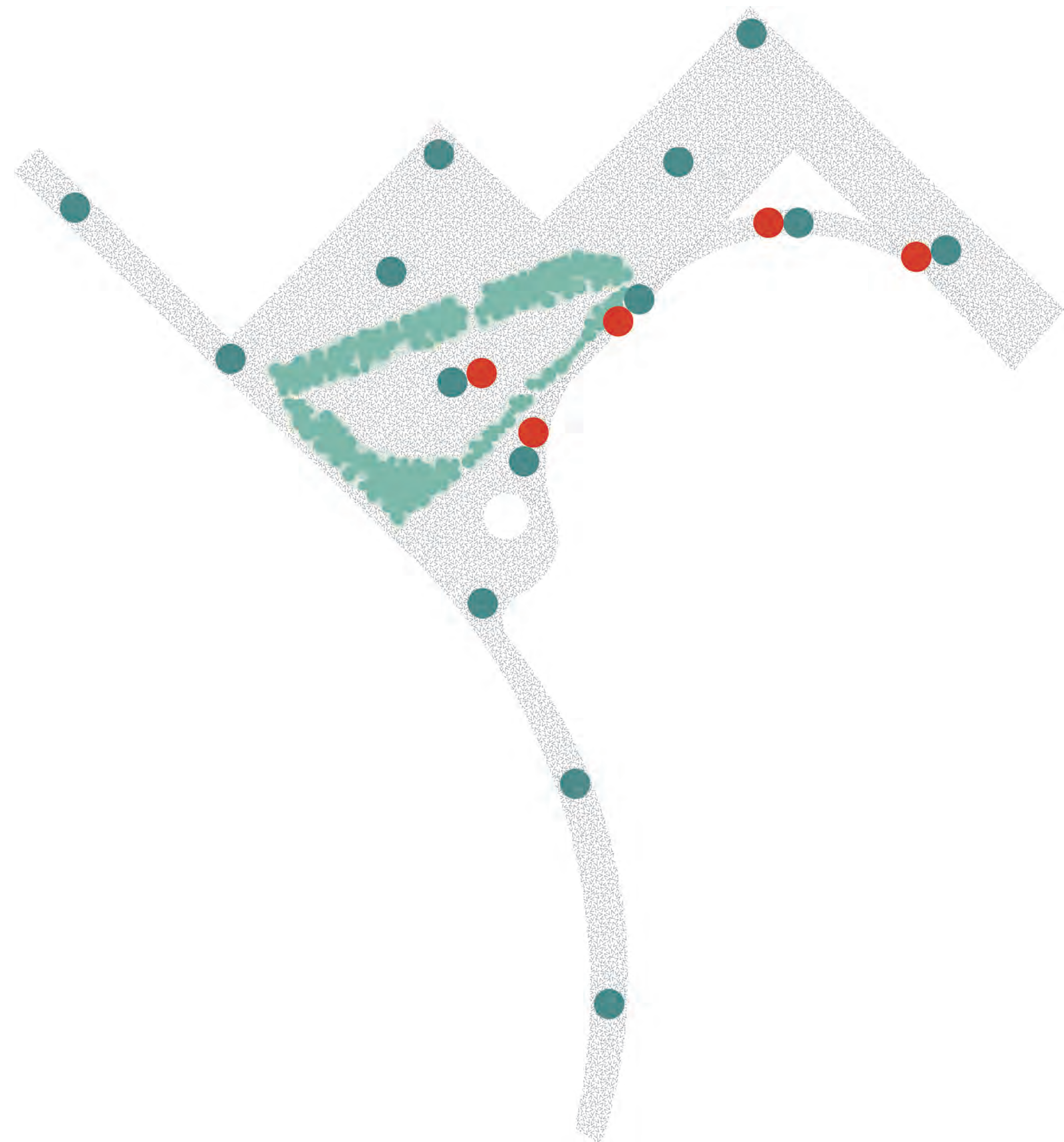

**Year 100+**

**nobody dies  
as technology  
advances**

- M|F indefinite
- B
- M
- L | | | | | | | | | |
- E | | | |

M|F Life expectancy [Male|Female]  
 B Burial  
 M Mourners  
 L Locals  
 E Education

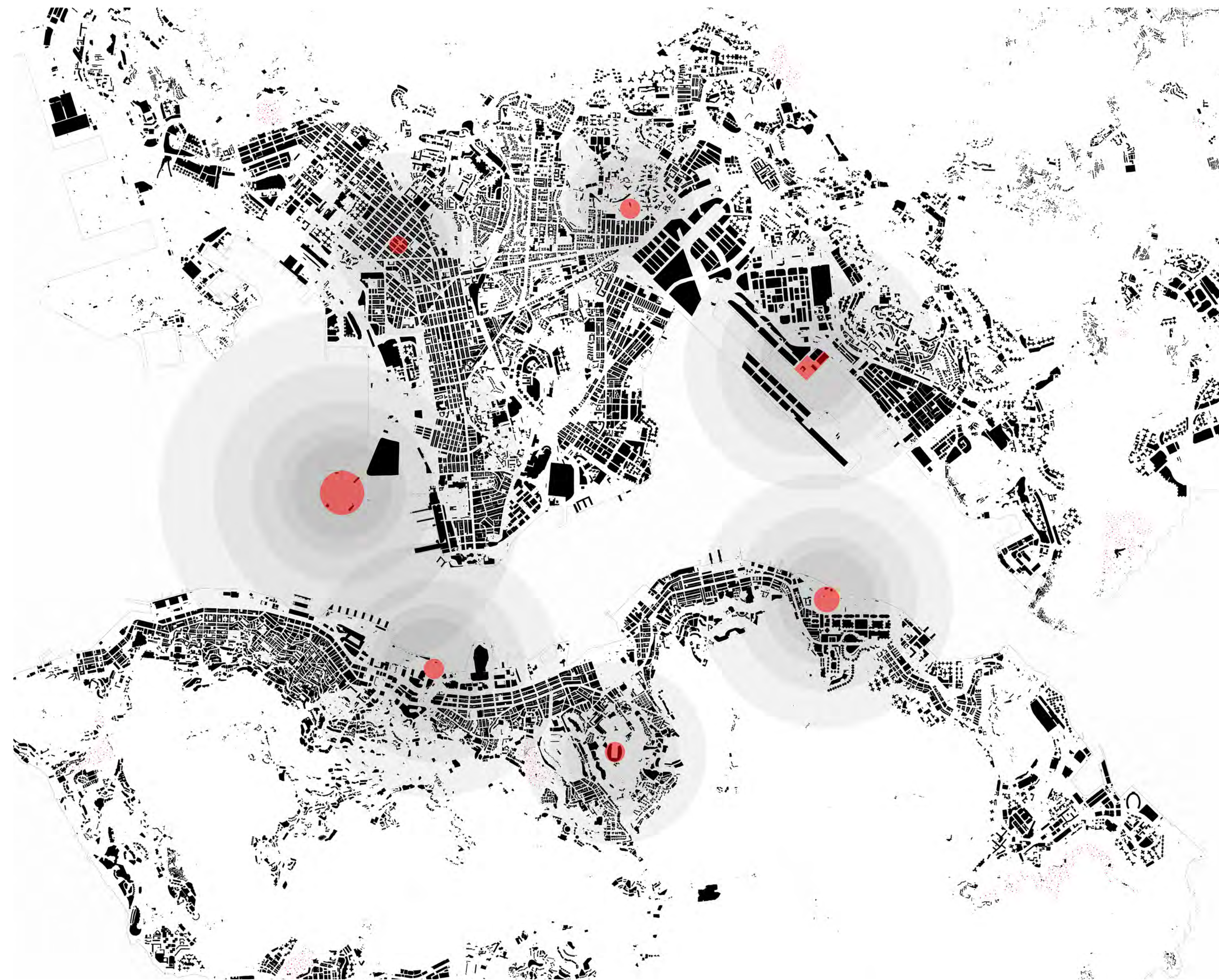

PROJECT VISION

prototype  
development  
extension





# after death

a multidimensional peace of mind

*I would like to dedicate this thesis to The Hungs.*

*Vicky*