

KNEE PROTECT

Winter knee protection

Ninni Elise Stedje



KNEE PROTECT

Winter knee protection

Ninni Elise Stedje

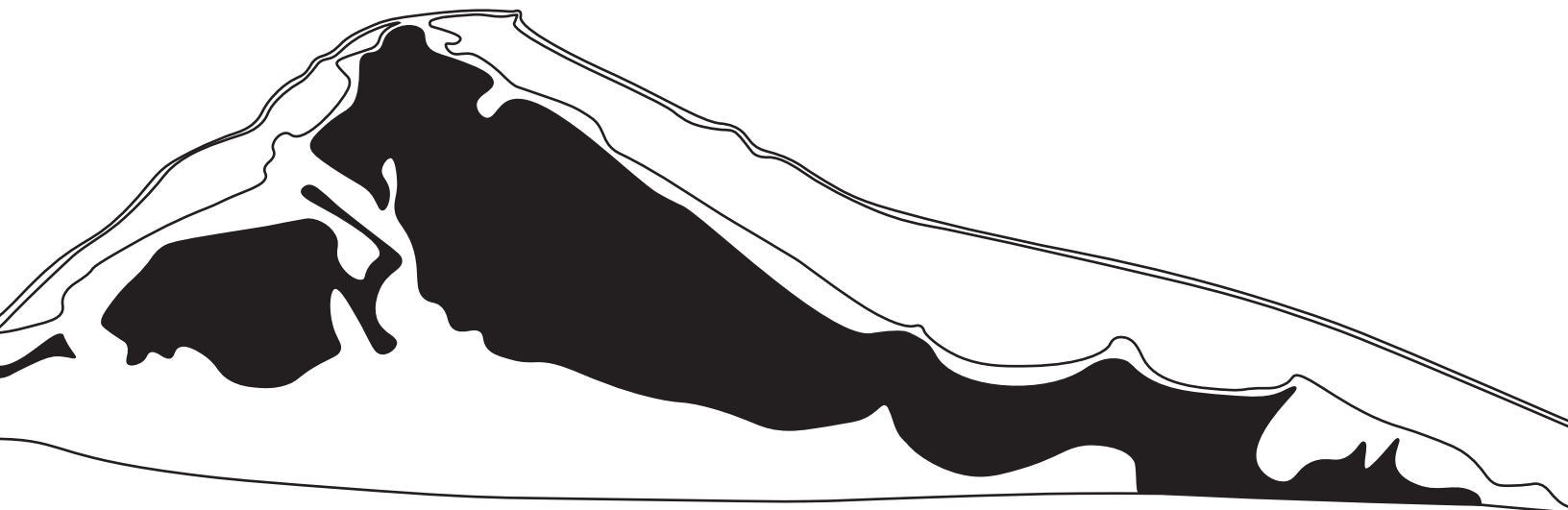



Diploma spring 2023

Title

Knee Protect
Winter knee protection

Diploma candidate

Ninni Elise Stedje

Institute

Design

Field

Industrial design

Main supervisor

Hilde Angelfoss

ABSTRACT

As many as 1 out of 3 competing athletes sustain injuries during the winter season. For the leisure skier on average 1,5 injuries happen every 1000th ski day. Although the number of general injuries while skiing, such as a fractured tibia, has fallen significantly over the past 30 years thanks to better designed bindings, damage to knees has increased, accounting for a third of recreational alpine skier injuries.

The aim of this project is to help prevent knee injuries related to winter activities such as skiing and snowboarding.

INDEX

Chapter 1	
Introduction	9
Motivation	10
Approach	12
Method insight	14
Method Concept development	15
Method product development	16
Context	18
User group	20
Contribution	22
Chapter 2	24
Insight	
The most common winter sport injuries	26
How is the knee built?	27
How an injury can occur	29
The Carving Skis	30
The injury of focus	32
Are knee braces helpful?	34
The market	35
Materials	38
Field testing	40
Interview	42

Expert interviews	43
User interviews	44
Sweet Protection interview:	45
Key insight	46
Summary of “Insights”	47
Chapter 3	
Concept development	49
Sketching	52
Systematically breaking down the object	54
Combining the elements	55
Playing with plaster	58
Using digital tools for sketching	60
Playing with shapes	61
Sketching out ideas for later testing	62
Looking at different ways of keeping the knee pad in place	63
3D print on fabric	64
Workshops	68
Knitting	69
Paper prototyping	70
Proof of concept	72
Mockups	74
User testing	76

3 concepts	81
Refining concept	88
CAD as a sketching method	90
Second workshop	92
Talk with an expert	94

Chapter 4

Final concept

95

Making the final sewing pattern	96
Final Concept modell	100
Details	104
Front	106
Back	107
kotekst	109

Chapter 5

Outro

113

Reflection	114
Special thanks to	115
References	116



Photo by Guillaume Groult, source Unsplash

Chapter 1

INTRODUCTION

MOTIVATION

I knew going into my diploma that I wanted to make something of importance. I wanted to use my position as an industrial designer to help improve or save someone's life from permanent injuries. My inspiration originally came from my mother, who had not too long ago injured her knee, making tasks such as walking the dog or going on a ski trip harder than before.

Another contribution for my motivation was a personal experience I had last winter, where I was at a ski resort with a friend. There I tested out snowboarding for the first time and had a pretty bad fall. The fall led to an injury, I can still sometimes feel to this day.

The more I learned about the subject, researching statistics of injuries, the more I saw an opportunity to contribute with something.

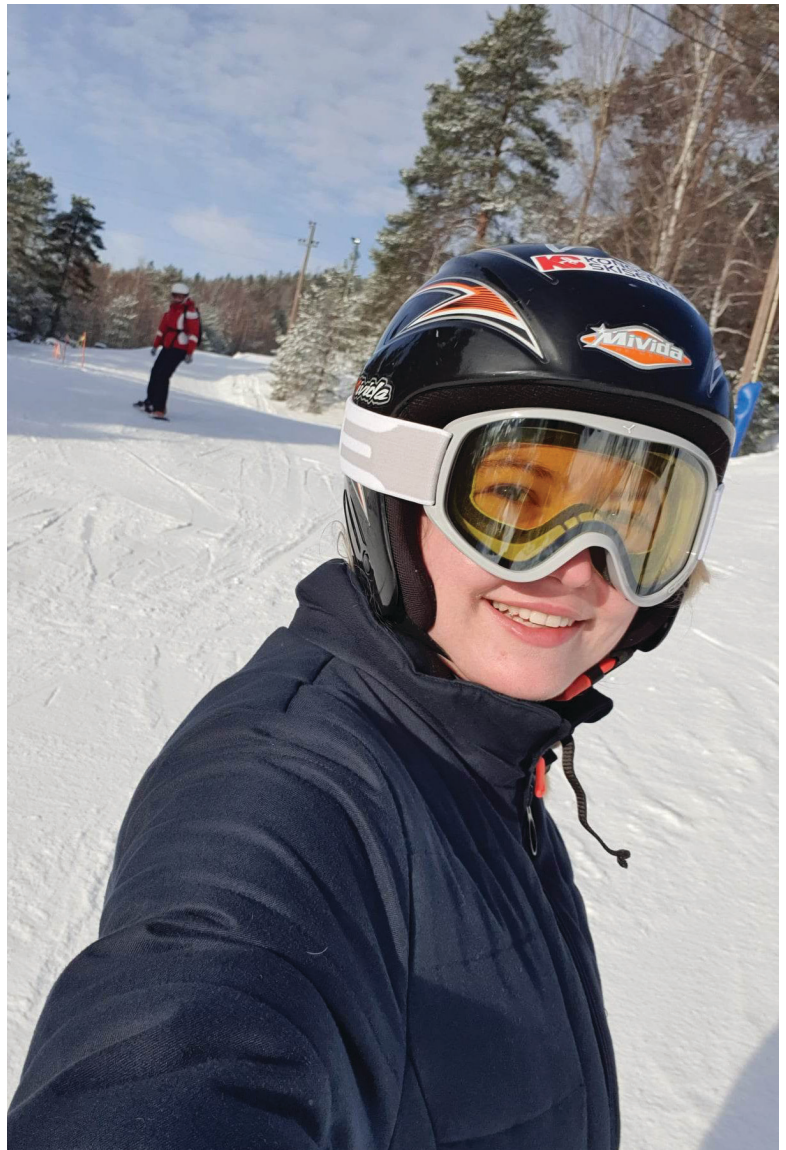

INTRODUCTION



Photo by Guillaume Groult, source Unsplash

APPROACH

My diploma project is meant to develop a new product. This product will be knee protection specializing in winter sports, and the challenges one can meet with certain winter activities. I have focused on defining the problem and ideating around it using practical “hands on” methods. Using a combination of different methods, I have investigated possibilities with the shape and function of my product.

My goal with this diploma was to create an innovative, new product that is yet to exist in the market. A product that would prevent certain injuries during downhill skiing and snowboarding. The intention for this product is not to function as support for an already injured knee, but rather prevent injuries from occurring.

I began the design process with the initial research phase: investigating the topic of common knee injuries, how the knee is built and what exists in the market today.

Additionally, I started experimenting early with using 3D print technology as a possible solution. The different 2D and 3D methods provided the base layer for developing my concept. In the end I came up with 3 different concepts, from which I then could finalize the concept that best solved my problem.

Initial insights

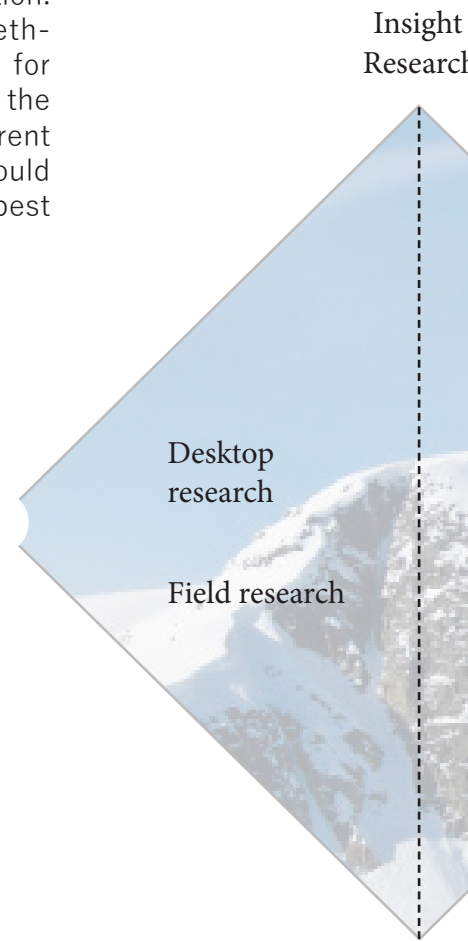

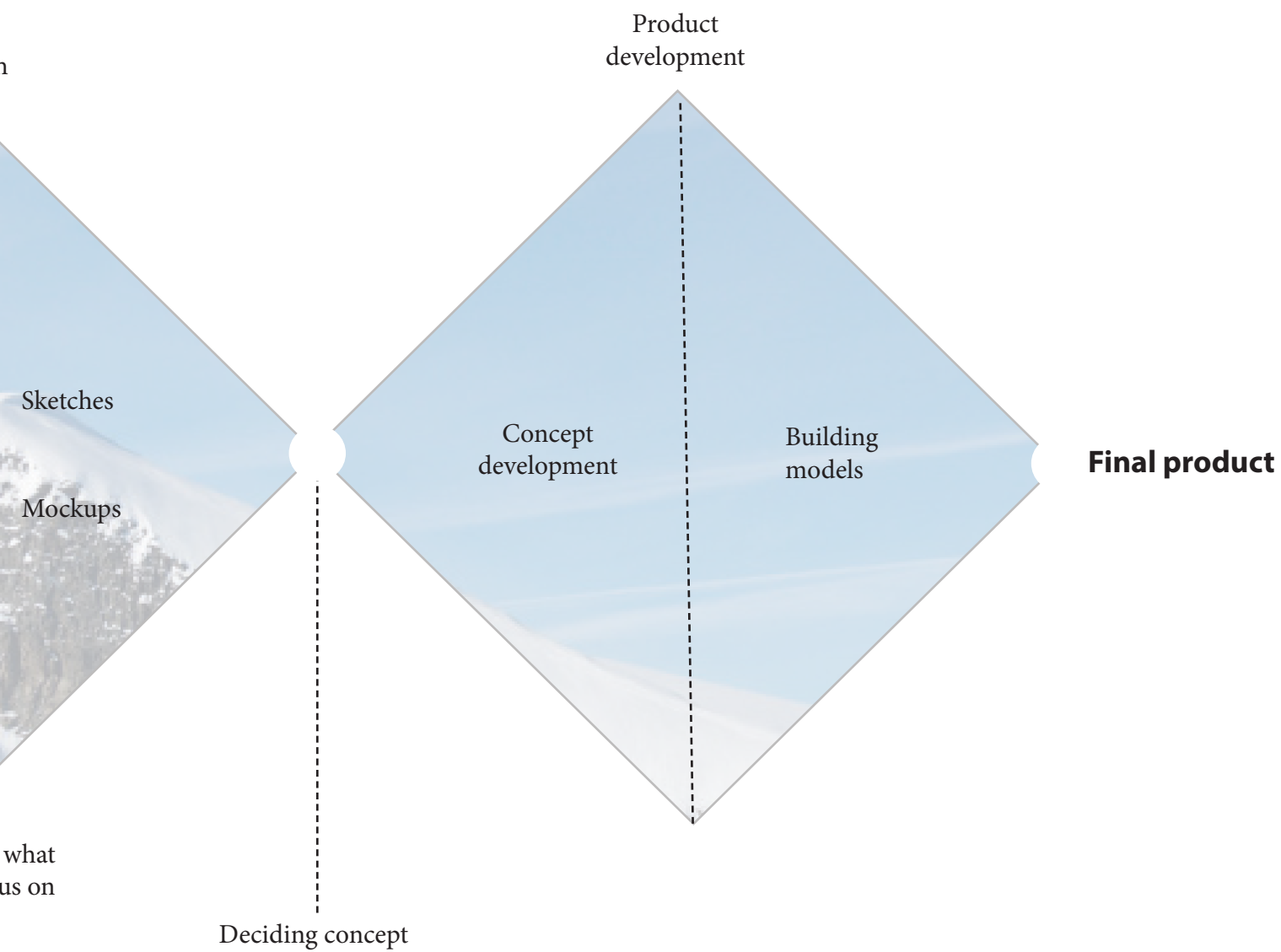



Insights

Desktop research

Getting an understanding of today's market

interviewing medical professionals

To get a greater understanding of the subject

Reading articles

Researching how knee ligaments work

Talked to Sweet Protection

Insight in the market and professional guidance

Interviewing people who have sustained injuries

Understanding the different needs and user wishes

Field testing

Insight work on location and activity



METHODS



Concept development

Systematic sketches

Making a solid foundation to start idea generating

Sketching

Visualizing ideas and producing concepts

CAD

Testing out accurate size and shape in a 3D world

Mockups

Fast feedback on size, texture and form language

3D printing

Testing out functionality

Workshops

Ideation and getting new and fresh ideas in

Moodboard

Determining aesthetics



METHODS



Product Development

Sewing

Used as a techniques to build the model

3D printing

Creating finer details and functional parts of the model

Product testing

Testing quality of my product

CAD Modeling

Building up final file for 3D print

Rendering

Showing my product in context



METHODS



Photo by Sebastian Staines, source Unsplash

CONTEXT

This project focuses on preventing twisting injuries to the knee that occur during winter activities, like snowboarding and downhill skiing. In this project, I looked into how the knee is built, different types of injuries and what possibilities I had as an industrial designer to prevent certain injuries from happening.

Skiing and snowboarding are seasonal activities that take place during winter and are enjoyed with a lot of snow. To scope the project down I decided to focus more on alpine activities such as slalom, snowboard and off-piste.



INTRODUCTION



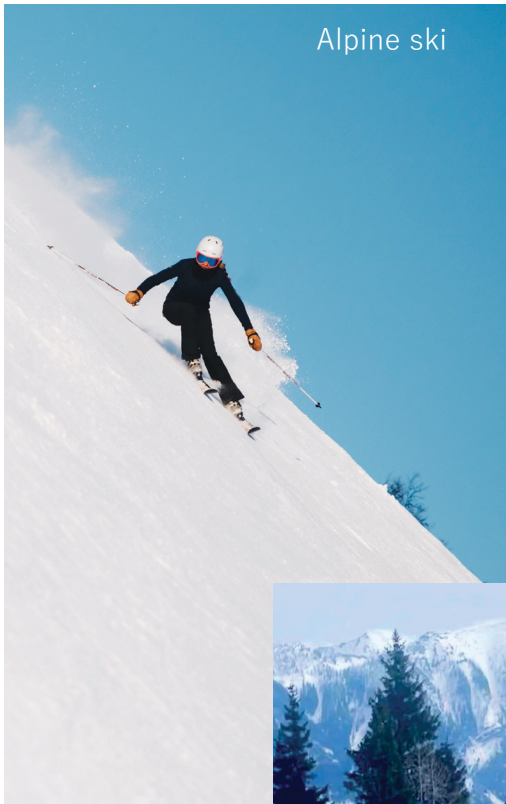

Alpine ski

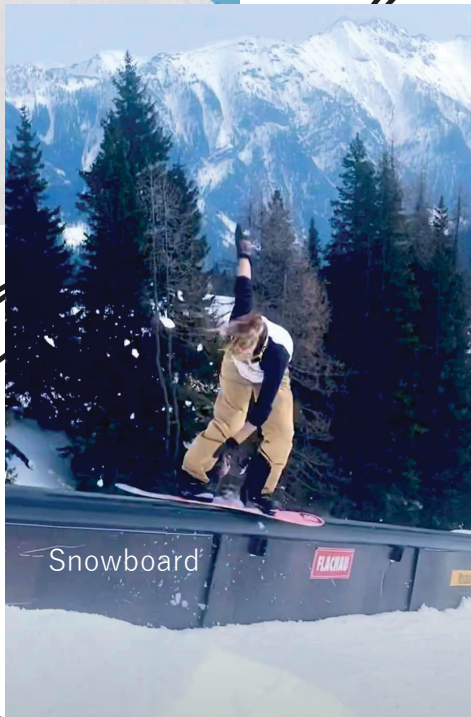

Snowboard



Off-piste

USER GROUP

I decided to divide the user group for my product into 3 different categories.

Alpine skis

-Alpine skiers have their legs separated for each ski. They use ski resorts and prepared tracks that can contain jumps or other intentional obstacles to perform tricks on.

Snowboards

-Snowboarders have their legs fastened together to the snowboard. Snowboarders also generally use prepared tracks that can contain obstacles meant for tricks.

Off-piste.

-An off-piste skier will use either a snowboard or skis. They do not use prepared tracks. Therefore, they usually only slide through powder snow. In some cases they have to walk up the mountain themselves instead of using a lift.

I felt it necessary to categorize them as such to find out what they had in common, and get a better understanding of what kind of protection would be needed for each sport. The way they use the mountain terrain is very different, so I wanted to make sure I could make something that answered the different needs.

I took inspiration from the backplate and its function in the market. The intended use of my knee protection not support of irreversibly injured knees, but prevention of injuries from happening - like with a backplate. I want to create a product that everyone can use, and will make them feel safe.

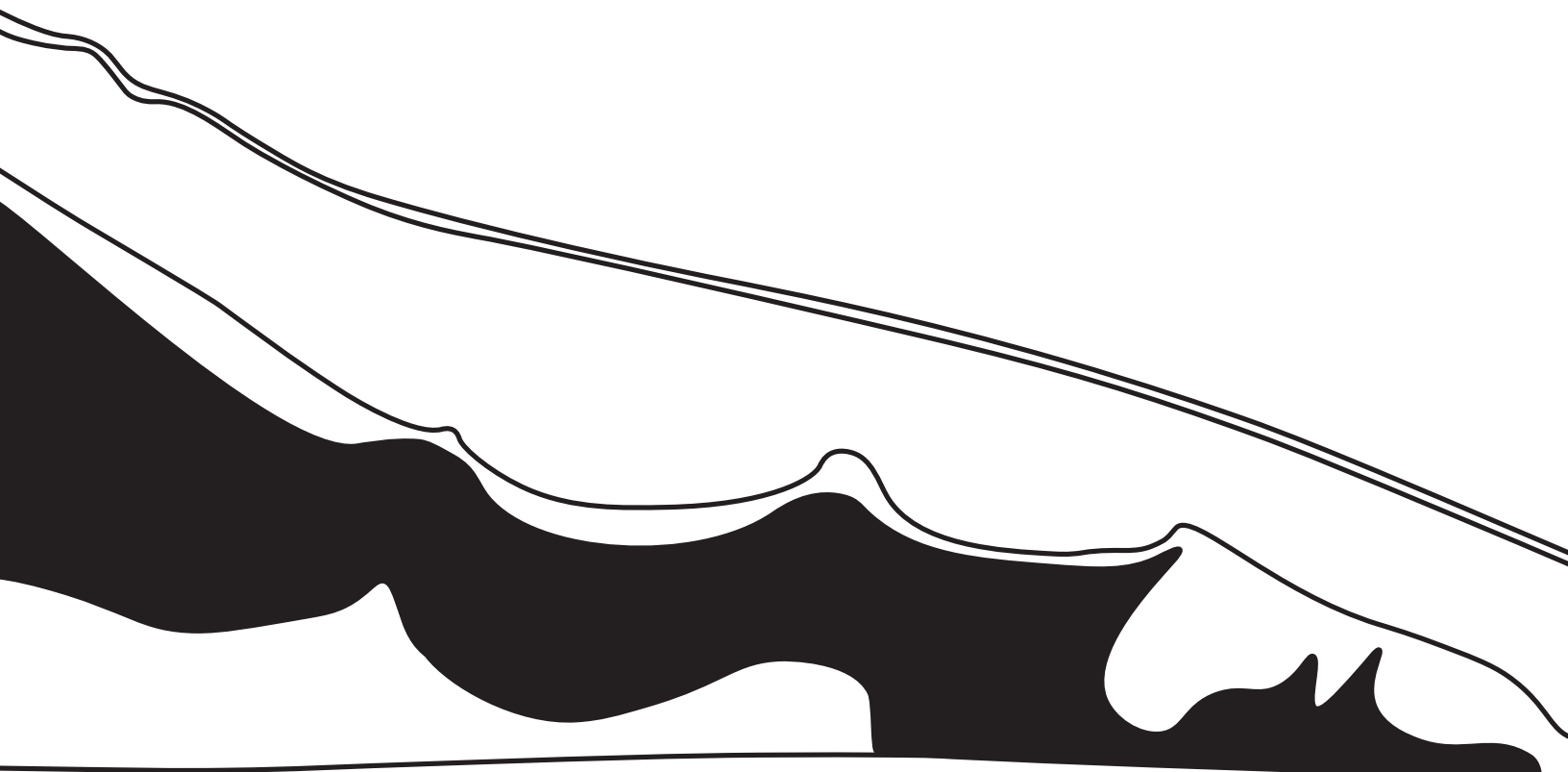



CONTRIBUTION

Lessen the risk of knee injuries

Making it more comfortable in between skiing activity

Help people feel secure when skiing or snowboarding



Photo by Sebastian Staines, source Unsplash

CHAPTER 2

INSIGHT

The most common winter sport injuries

When starting my research on winter sports injuries, I focused on identifying the types of injuries that commonly occur. Through an analysis of relevant statistics, it became apparent that knee injuries were especially prevalent.

Upon further research, I discovered that while our bones are durable, the joints that connect them are vulnerable. In fact, joints are the weakest points of the skeleton, and the knees, being the largest and most used joint in the body, are especially prone to injury. [3] [7] The knee joint is built for stretching and bending in primarily one axis. Most knee injuries are due to extreme twisting, turning and shock. [2], [6] The most common skiing knee injuries are MCL, ACL and torn meniscus. A tear to the MCL or ACL can range from partial to complete tear. [1] [2] Regardless of the severity, these injuries tend to have a lengthy recovery period. In the case of a complete tear, a surgical procedure may be necessary to sow the ligament back in place.

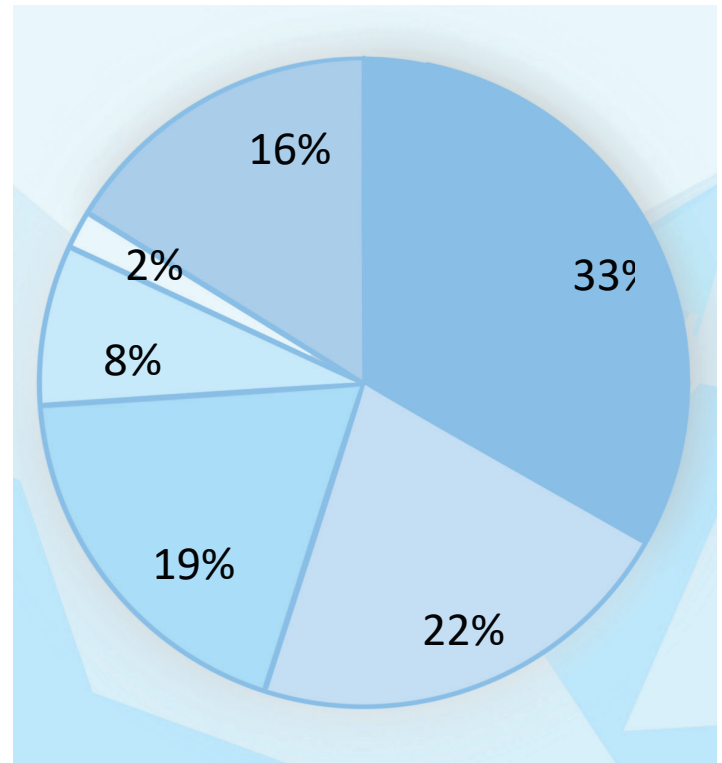

33% - Rotasjon
22% - Phantom fot
19% - hyperekstensjon
8% - støvel
2% - Kollisjon
16% - Andre

How is the knee built?

The knee is a hinge (bicondylar) joint, which consists of three main bones. On the upper side of the joint are the bones connected to the hip: the femur. The lower part of the knee joint is connected to the tibia and shinbone. The fifth bone in the knee is the kneecap. It is a small bone located in front of the joint, which moves with the knee when it is bent.

The knee has four ligaments which are responsible for movement and keeping the knee together. Firstly, there are the ant cruciate ligament (ACL) and the post cruciate ligament (PCL). These two ligaments form a cross in the middle of the knee joint. The ACL is connected from the tibia, right beneath the kneecap, to the femur behind the knee joint. The PCL ligament connects the front of the femur to the back of the tibia. These two ligaments are the shortest ligaments in the knee. On the sides of the knee are the lat collateral ligament (LCL) and med collateral ligament (MCL). The collateral ligaments connect the femur to the shin-bone (LCL) and the femur to the tibia (MCL). [15 [17] [16]

The final component of the knee is the meniscus. The meniscus is two crescent shaped discs of cartilage that lie in between the femur and the tibia. They absorb and distribute the shock from jumping up and down for example.

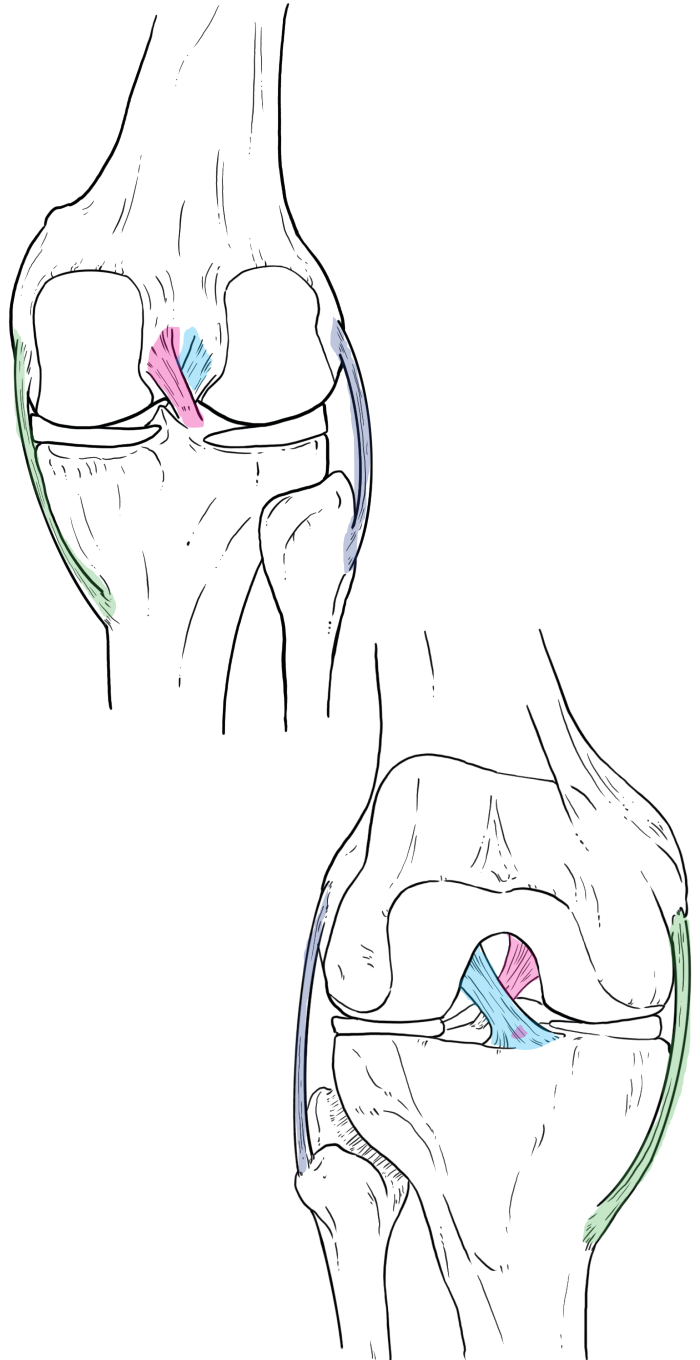



Photo by Philipp Kämmerer, source Unsplash

How an injury can occur

Valgus–external rotation:

The valgus-external rotation position is a type of knee position that can occur while skiing. It involves the knee joint moving inward (valgus) and rotating outward (external rotation) at the same time. This position places significant stress on the medial collateral ligament (MCL) of the knee, making it vulnerable to injury. The valgus-external rotation position can happen when a skier loses their balance, or is attempting to turn sharply, causing their skis to carve into the snow and altering their direction. [14] [3], [4], [7] [17]

Other common causes for injuries are:

Phantom foot:

This is when your hip lays below your knees. Making you unbalanced which can result in an accident.

Boot-induced Mechanism:

Commonly occurs when landing from a ski jump. The ski tail contacts the snow first. [14]

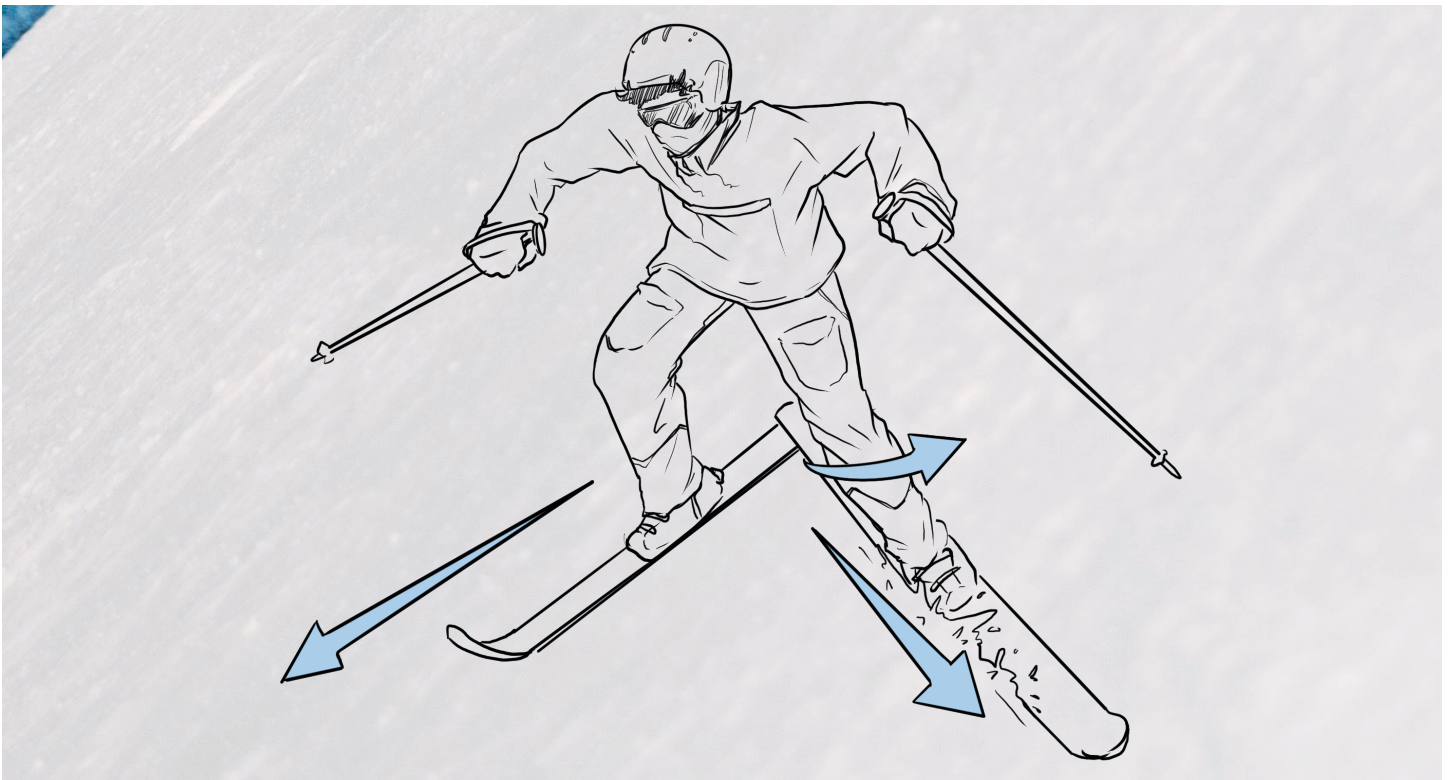
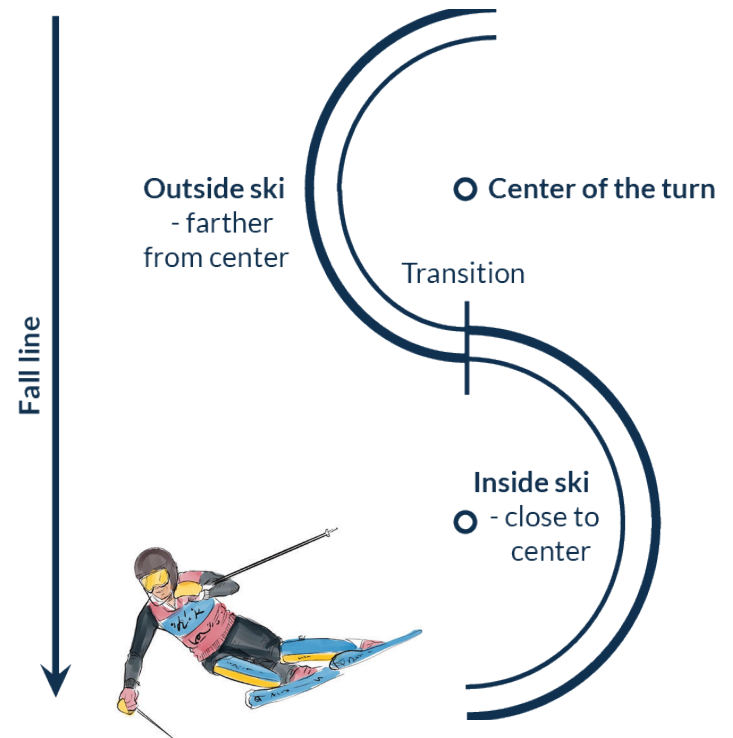

The Carving Skis

Alpine skis/downhill skis have a circular cut on both sides that makes the width of the ski greater at the tip and the tail. This will let the ski carve down in the snow, allowing the user to make sharp turns when weight is put on the ski.

This also means that the ski can easily dig into the snow even when you don't intend to make a turn, resulting in the knee taking a sharp turn, jolting off to the side. [8]

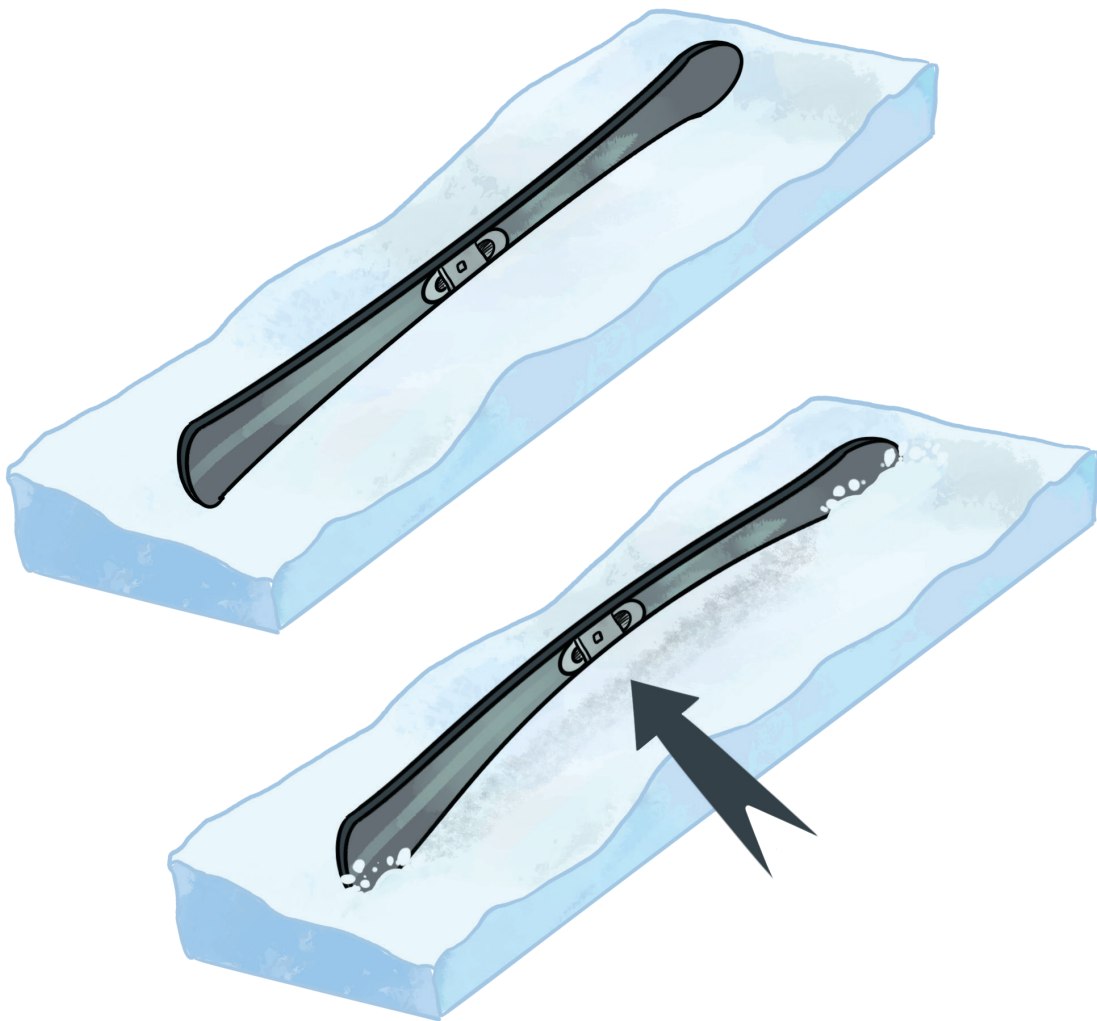

Presented here are some examples of how different skis have different curves. The most common skis today for downhill skiing are the carving skis with the biggest curve. Their popularity lies in the fact that they are easier for beginners to control.

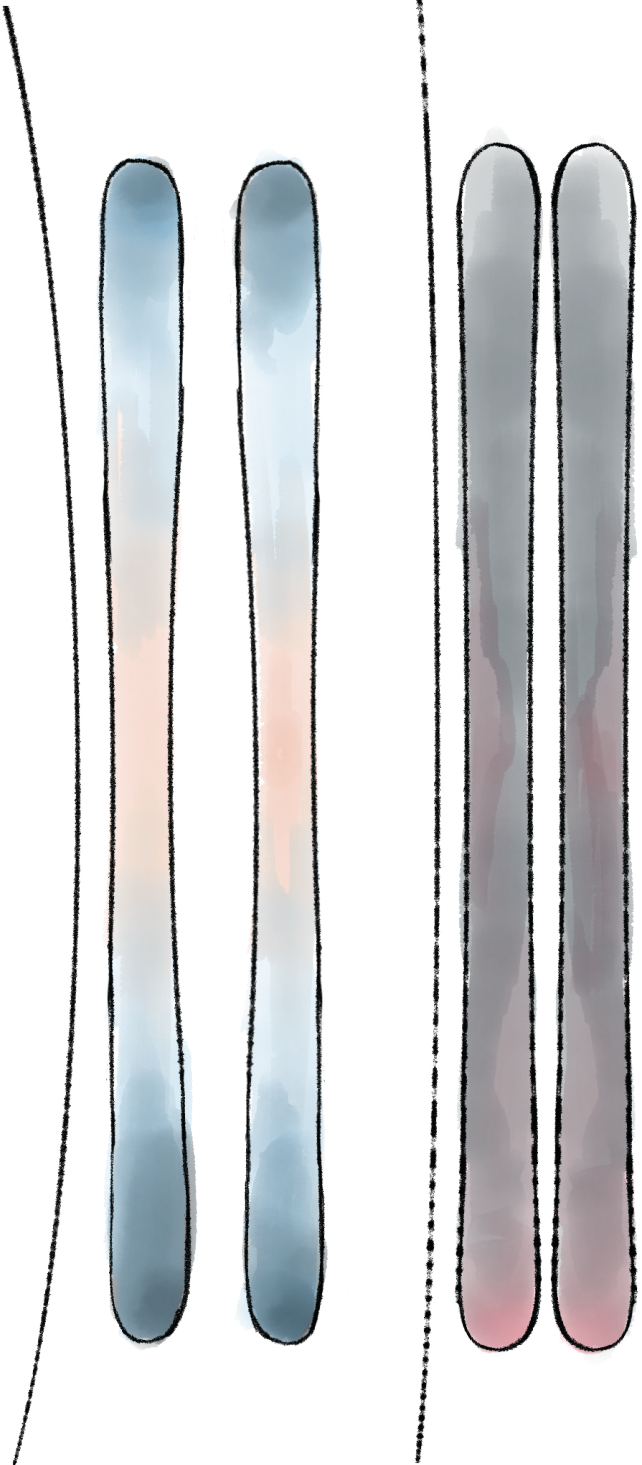

Carving skiis

Taditional skiis

The injury of focus

Between ACL and MCL injuries, I decided to focus on MCL, despite the fact that ACL tears are the most common injury. I concluded that this was the best option after researching about which forces cause the different injuries. Focusing on the ACL injury would mean preventing a small movement in the lateral axis. Doing this would mean giving the user less mobility and more discomfort. Focusing on MCL lets me create a knee pad that won't hinder the user's mobility, but will still stop or reduce the risk of the MCL tear.

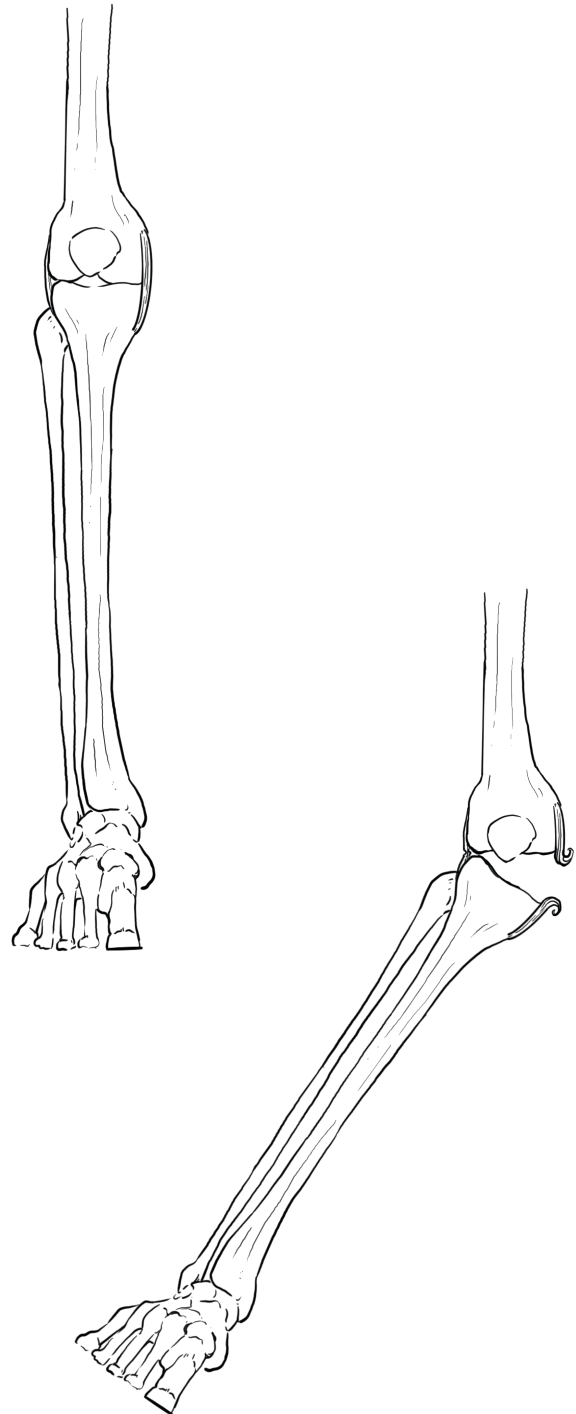

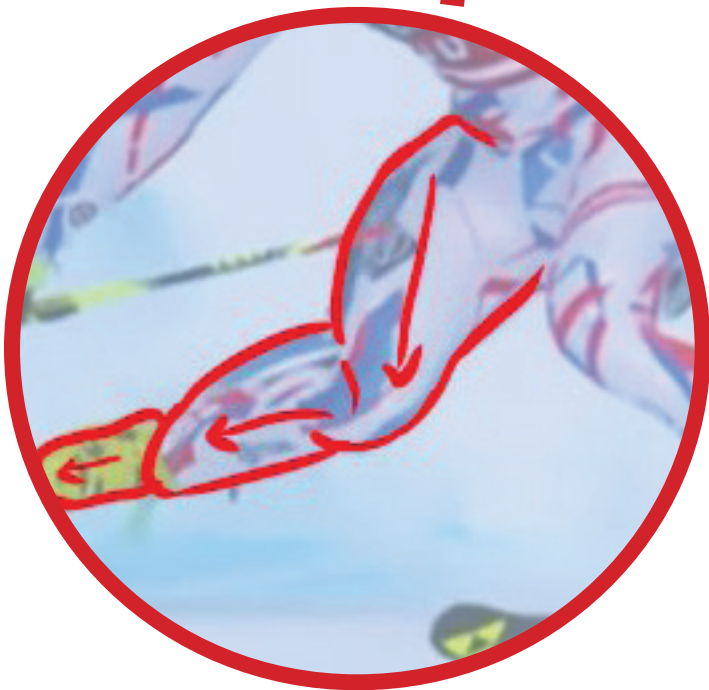
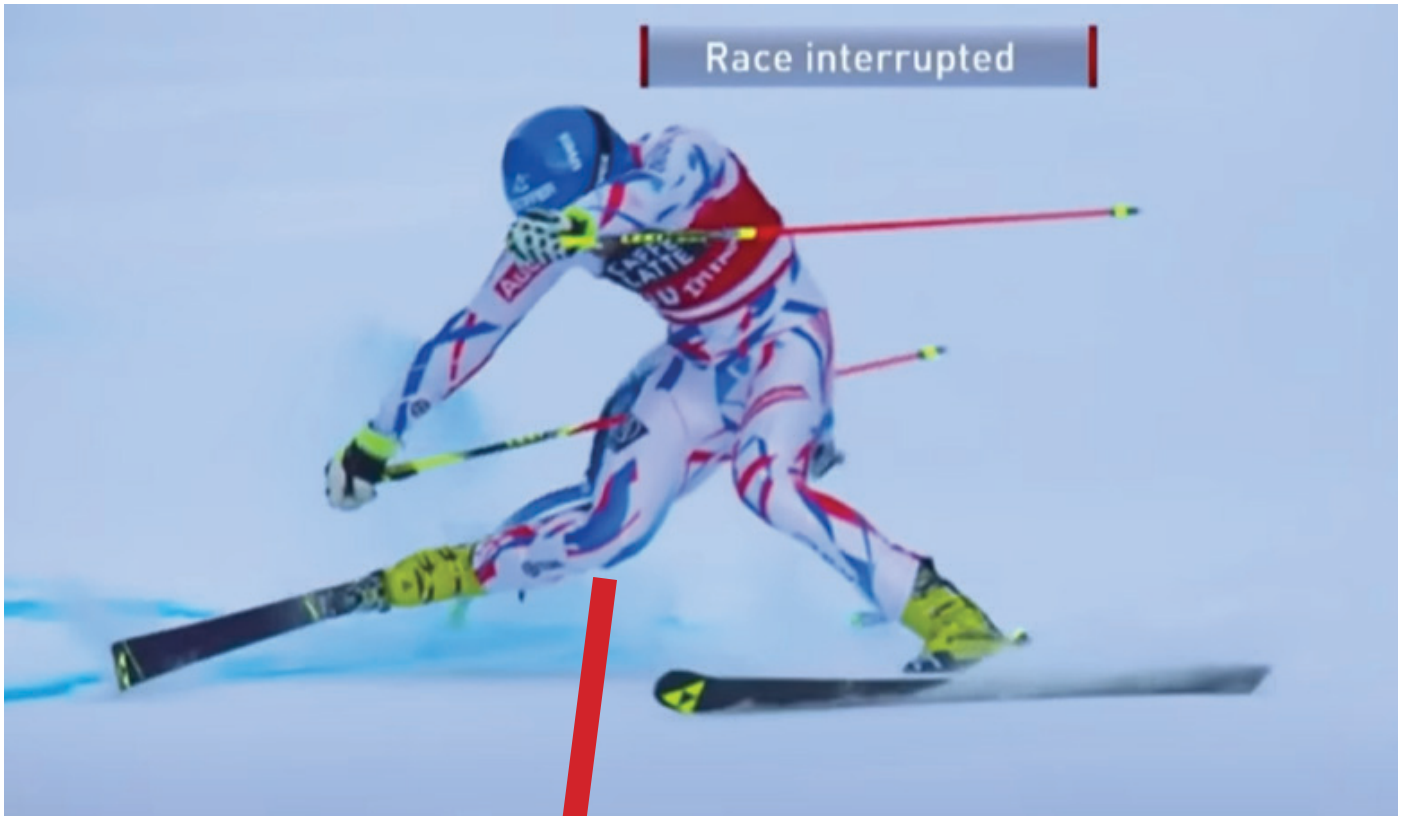

This is an example of an MCL injury during the ski world cup:

Here you can see an example of how the skier's right foot has been caught in the snow, which has caused their knee to rotate outward in a valgus-external rotation position. If a skier experiences this type of incident, it's important for them to stop skiing and seek medical attention if they experience pain or instability in their knee joint. [18]

Are knee braces helpful?

I attempted to get an expert's view quite early in my process but as this is a subject with very little general data, it proved a challenge to get any clear statements. Mailing back and forth with different experts such as chiropractors, personal trainers and orthopedists, resulted in a rather divided standpoint. Some recommend using braces, while others say that it is mostly placebo. Their general consensus was that keeping the knee warm has benefits when it comes to avoiding injuries. [9], [10], [11]

A common answer I got when pitching my idea spoke of a lack of documentation, and expressed that preventative training is the most important thing one can do.

«In short, I would say that there is little documentation that it can be preventive. In that case, injury prevention training is much more important»

- Chiropractor

The Market

During my research, I started to differentiate between medical braces and sports knee pads. Some of the key findings during this stage, were that medical knee braces mainly support ligaments/ kept the kneecap in place. The medical braces were made to restrict movement, almost functioning like a cast. Sports protection however is heavily targeted towards impact absorption. Different knee pads have different lengths and amount of padding, depending on what sport they are aimed at.

When looking at the market, I took everything from the 1970's to today (2023), and mapped out the aesthetics of the safety equipment.

Sports



Medical



Type of market

I decided to map out different parameters of qualities I found important like user arena, price range and aesthetic values.



I figured only dividing the knee gear into “medical” and “sports” wouldn’t give me enough input, so I further developed it to a polarization diagram, adding soft and rigid as set qualities. Further categorizing like this gives me a better idea of where I want to be in the market.

miro

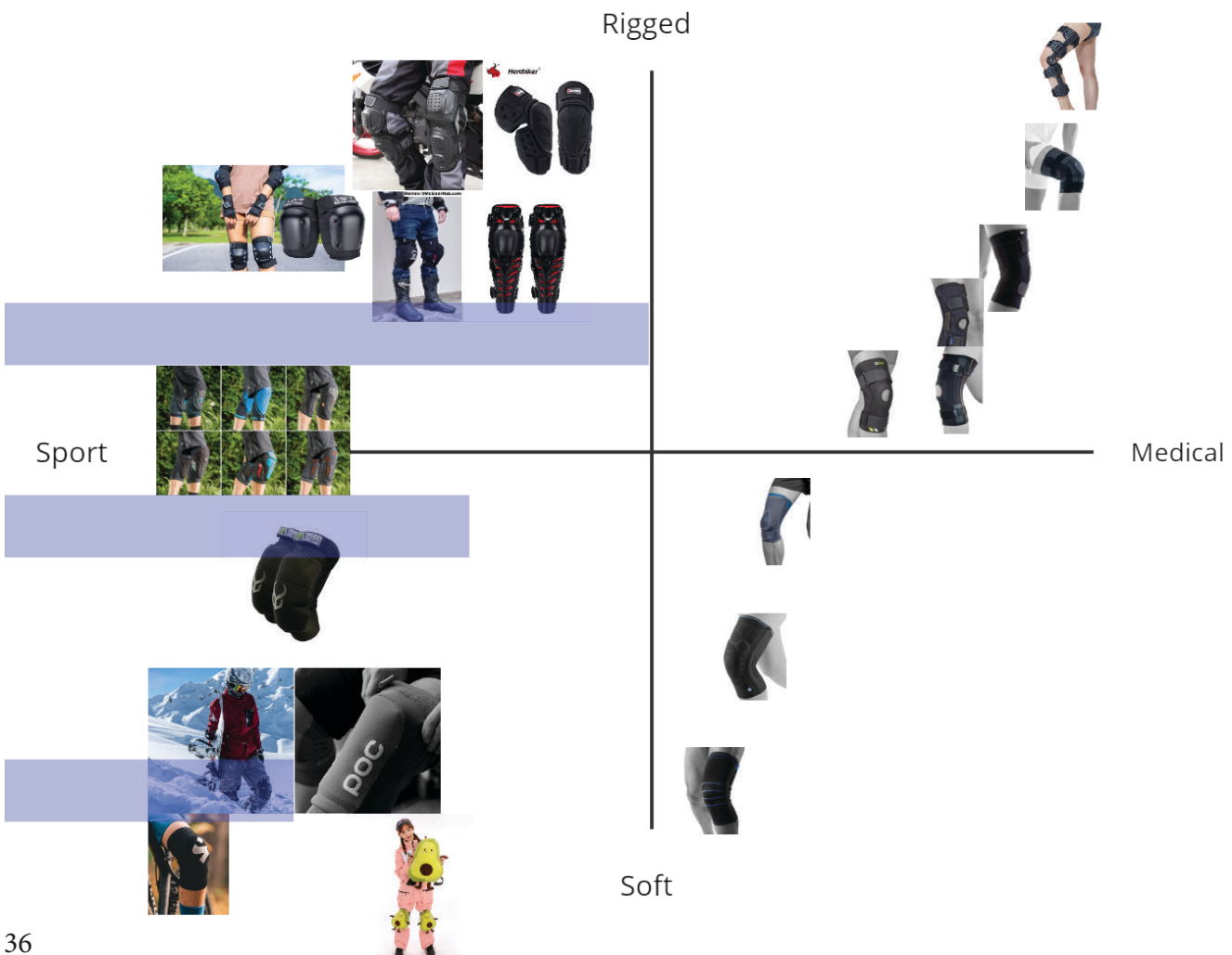

miro

Where in the market?

Next I looked at the price range. After taking a lot of inspiration from Sweet Protection and looking at their products I decided that matching their price range would be the most realistic thing for my own product.



Visual Aesthetics

Lastly, I took a look at aesthetics ranging from functional to decorative. My own product is supposed to feel serious and function oriented. Therefore, I decided that in this case a clean design that would showcase the functionality of the product would be the most fitting. I want my own product to be perceived as something you can trust.



Additionally I will be aiming for a class 2 certified product, meaning the product can be used in rough terrain.

Materials

Textile 1: 3D air spacer fabric 100% polyester scuba fabric air layer.

It's a soft material that has a cushioning effect. It can be worn for longer periods of time even when exposed to water without leading to irritation of the skin. The 3D space in the fabric keeps it warm and comfortable. Helping the knee stay warm during periods with less physical activity, like the ski lift. The fabric is stretchy and will form itself to the leg, making it snug and less likely to slide out of place when in use. It's also a quite robust fabric making it less likely to tear if one should fall on the snow or ice.

Textile 2: A 100% Polyester 75D Mesh Fabric

This fabric is commonly used in sports clothes. One of its key functions is its breathability, which reduces risk of perspiration which may lead to the knee ligament cooling down, increasing the risk of injury. The fabric is also thin and stretchy, making it perfect to use on the back side of the knee where the fabric has a tendency to gather.

Molded knee pads: visco elastic foam. Fitted to the knee with ventilation holes.

For the knee protection that focuses on impact damage, a visco elastic foam (similar to hard memory foam) that is molded into shape to fit the knee, will be used. The foam will harden during impact and spread the forces over a larger area. This foam is most commonly used in back protection gear, but is now being used more and more in cycling knee protection as well. This material is good at giving the user more movement without lessening the protecting effect.

3D air spacer fabric 100% polyester scuba fabric air layer.

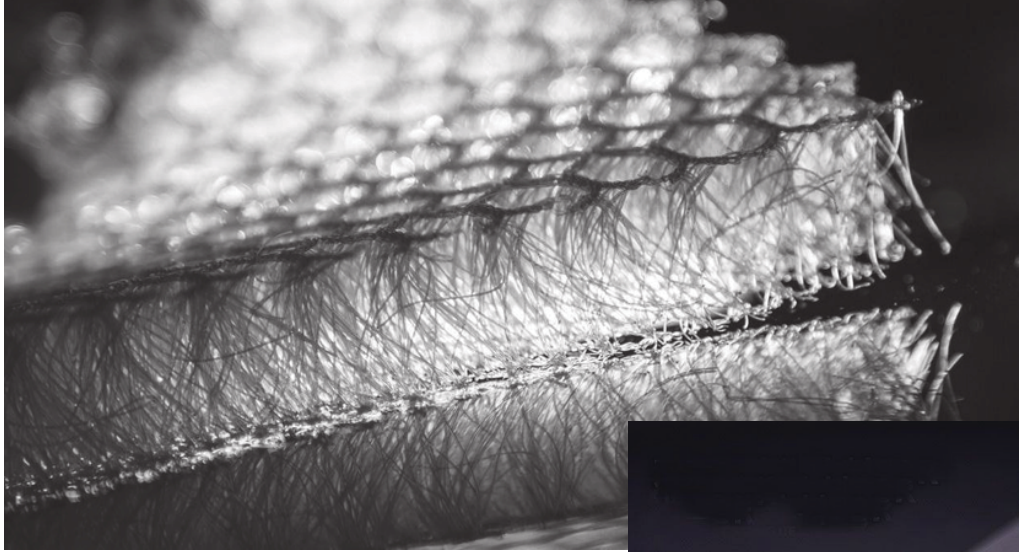

100 Polyester 75D Mesh Fabric



3D air spacer fabric 100% polyester scuba fabric air layer.

Field testing

I spent a day on the slopes to both enjoy the winter weather but also get in some research. I decided to test out an early mockup that only functions as an additional layer keeping my knee a little bit warmer. The main purpose with this test was to see if it had any effect on comfort when it comes to temperature (keeping the knee warm), and to see how the material I picked out would feel after a full day of use. I only wore the knee pad on my right knee that day in order to notice if I could feel any difference. After the full day, I found that the knee pad was comfortable to wear all day, and my right knee felt a bit more comfortable than my left knee, especially during ski lifts.

Using myself as a user tester did concern me a little bit, since I was afraid of being biased, and experiencing placebo. Therefore I have taken these possibilities into account, when judging the results of the day.

It was motivating to feel the project had somewhat of a realistic foothold this early in the process. This experience also made it very clear that I would need user testing from other people further into my project.





Interview

As previously mentioned I attempted early on to get various experts' opinions on the subject of knee protection. In addition to those interviews, I also conducted several interviews with different potential users as well as a member of Sweet Protection's staff, in order to get professional input and guidance in the industry of protective gear for sports. Here, I have collected the main takeaways from each interview.

Expert interviews

Medicine student:

Q:
Can you tell me how the knee is built?

A:
The knee is only supposed to be bent one way. The thigh consist of 4 main muscles. Some are on top of the knee and some below the knee. This is to keep the kneecap stable.

Chiropractor/personal trainer:

Q:
How can you prevent a knee injury?

A:
The best way to prevent the ligaments from tearing is to build up the thigh muscles. The lower leg muscles do not support the knee. The ligaments inside of the knees are most prone to tears (ACL). This is because they are shorter and therefore don't stretch very far when it comes to sudden movements.

Q:
How much can a knee joint take before an injury occurs?

A:
The amount of force a knee can take? It varies, but unfortunately you don't need a lot of force to tear a ligament. All you need is an unfortunate movement.

Q:
Can support prevent injuries?

A:
Some supports could. If they were on the inside of the knee. But if you use them, then focus on training. Training is number one in keeping a healthy knee. Even with knee supports you should still be working out the thigh muscles. A brace would be appropriate if your ligaments are too long, and they can't do their job properly.

Key insight

The knee is built to only bend in one way and is stabilized by thigh muscles and ligaments. Ligaments inside the knee are prone to tearing due to their short length.

A brace may be necessary if ligaments are too long to do their job properly.

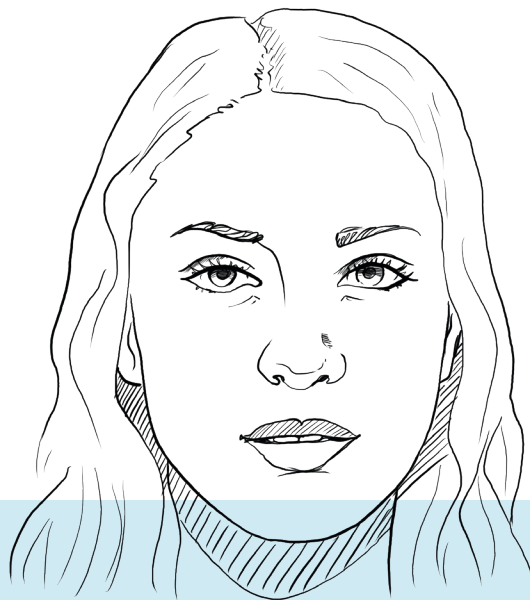

Main insights

The knee is built to only bend in one way and is stabilized by thigh muscles and ligaments.

Ligaments inside the knee are prone to tearing due to their short length.

A brace may be necessary if ligaments are too long to do their job properly.

User interviews

Person with both a torn ligament and damaged meniscus:

«It [their knee support] has soft boning on the sides and padding for the knee. I also have another one that's open for the kneecap, but it doesn't give enough support.»

Person with a healthy knee:

«When you fall it hurts, but when that's over you want to keep going [...] You'll get water in your knee and that hurts to land on. It would be nice to have something to keep things in place you know? [...] I would like to use knee protection to protect against impact damage.»

Person who has had multiple operations:

“I go back and forth on whether I should use braces. But they never feel good. They are heavy. I injured myself while wearing them. I read that knee braces trick you to think you're safer than you are. I constantly think about my knees when snowboarding, it's tiring.”

Person who has an ACL injury:

“I used a knee splint. It was extremely uncomfortable, I didn't feel safe. Didn't trust the knee so the muscle grew askew. I do have a back protector, but I never use it. It feels like I have a shield on my back”



Main insights

One of the users with a healthy knee expressed interest in using knee protection to prevent impact damage. Another person who had multiple knee operations found knee braces uncomfortable and heavy. Someone with an ACL injury used a knee splint but did not feel safe or comfortable with it and developed muscle imbalances.

Sweet Protection interview:

Ståle Møller, Sweet Protection:

“If the knee protection covers the whole knee it’s more efficient than if it is open in the back. Preferably extending 5-10 cm above the knee cap. Every protection against impact should be as close to the body as possible. Try not to separate the surface into smaller segments.”

“When I make a test machine, I have to make it as simple as possible to isolate what I want to test”

“Print on a non-elastic fabric. For example airbag textiles.”

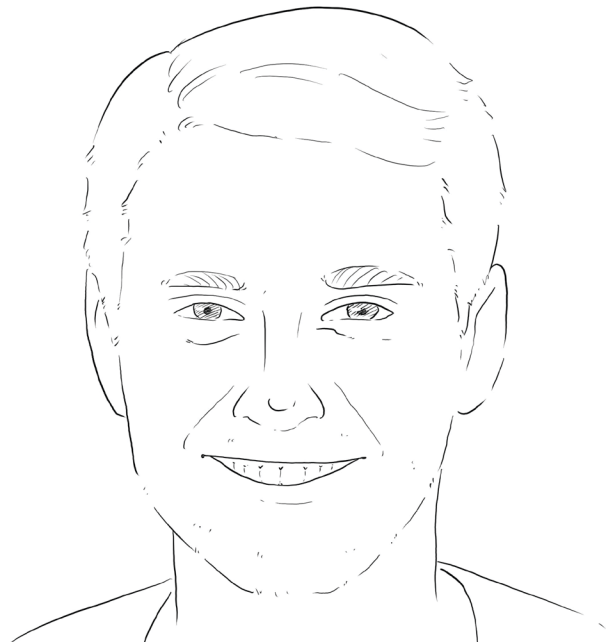

Main insights

Knee protection should cover the whole knee, extend 5-10 cm above the knee cap, and be as close to the body as possible, without separating the surface into smaller segments.



Key insight

Knee injuries account for approximately 30% of all ski injuries.

MCL injuries often occur due to Valgus–external rotation.

Medical experts are divided on whether knee braces have a positive impact for skiers. The medical market focuses on support while the sports market focuses on impact protection.

Protection gear should be on the innermost layer for best outcome.

The knee pad should be class 2 certified for rutter terrain.

Summary of “Insights”

My research led to focusing on MCL injuries, which occur when the medial collateral ligament in the knee joint is stretched or torn due to inward force on the knee, commonly seen in skiers. I delved into the market for knee protection, and discovered that medical braces primarily aim to support ligaments, while sports knee pads concentrate on absorbing impacts.

Using this knowledge, I set out to design a knee pad that could provide both support and impact protection. To achieve this, I developed a prototype knee pad using 3D air spacer fabric for cushioning and warmth. During my testing, I found the knee pad to be rather comfortable to wear, especially under ski lifts rides. However, I recognized the need for further testing to evaluate the knee pad’s effectiveness and overall comfort level for users.



Chapter 3

CONCEPT DEVELOPMENT

MOODBOARD

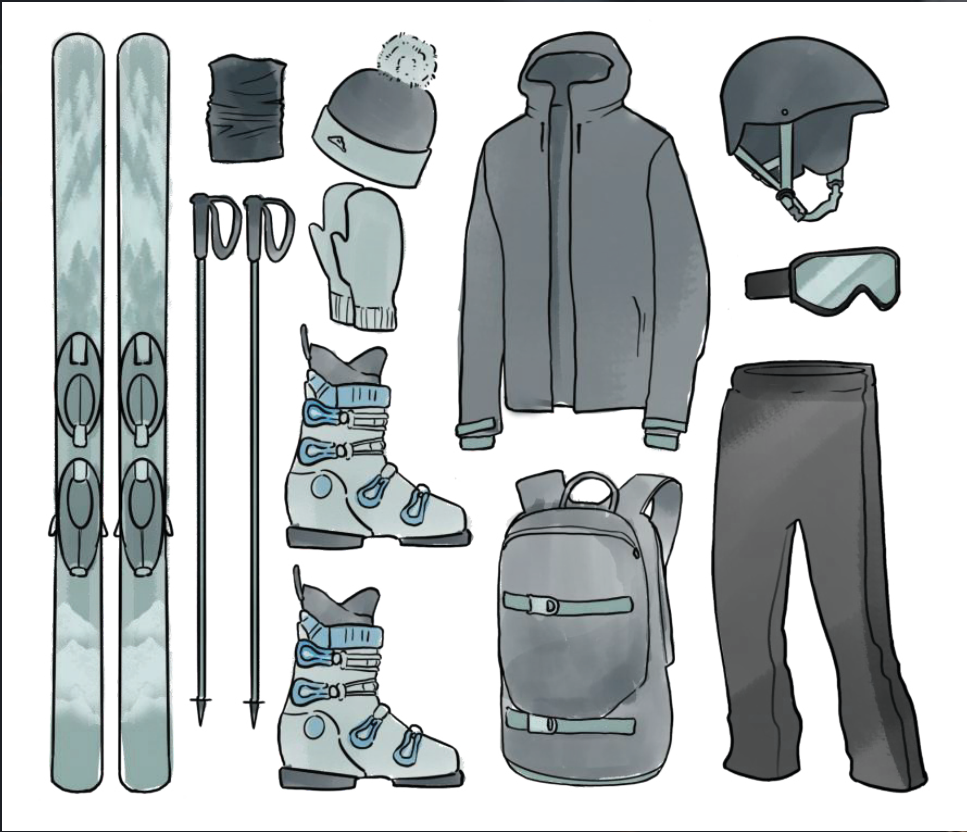
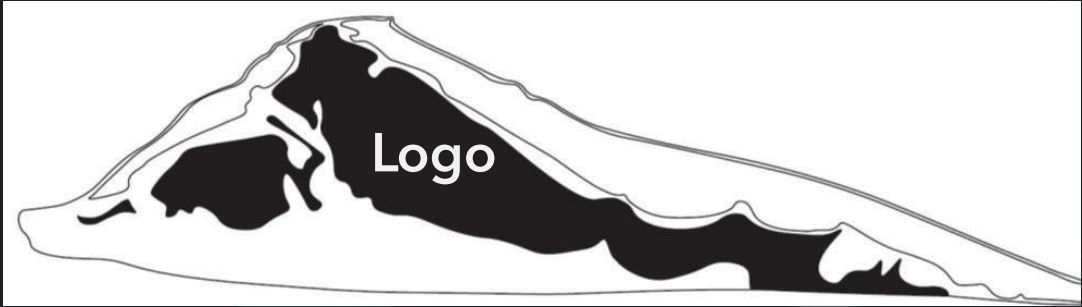

Readiness



Stitchin



In-between times



ng



C
o
l
o
r

C
o
m
f
o
r
t
a
b
l
e

C
o
l
d

C
a
l
m

SKETCHING

The nature of my product being a type of protective gear made prioritizing function before form a natural approach.

I knew I wanted to be hands-on in my process, so I ended up working parallel between 2D and 3D space. I worked with traditional sketching, 3D painting, cad sketching and sewing simple mock-ups. This was to see how the different forms translate from flat sketches into physical objects, further helping decide which direction I should go.

I decided to take this parallel approach, because this way I could easily determine where the different types of fabric should be placed. What made it more comfortable to use, and to get an understanding on how I could make an object fit to such a challenging body part.

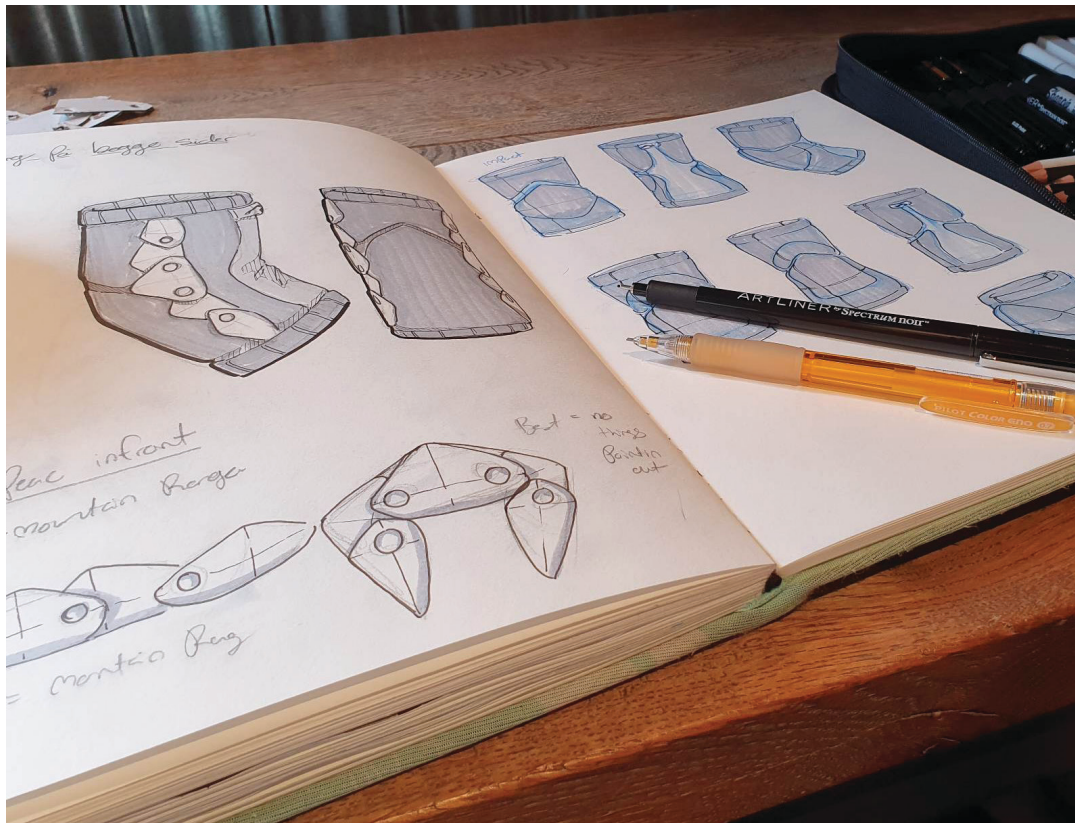







































Systematically breaking down the object

I started with a technique, where I used a systematic way of sketching, breaking up the objects into its individual functional parts. From there I made a grid pattern, where I could test out how different parts could look like with the same or different prompts.

KNEEPAD

		Soft	Rigid	Hidden	Expressive	Movable
Upper Connection 	 fluffy	 Elastic Band				
Cushion 	 Foam	 Thick fabric	 Plastic sheets	 Metal	 Under fabric	 Pocket
Ventilation 	 Foam fabric	 Ring	 Ventilation holes	 Zipper	 Mesh	 Zipper
Maintain heat 	 Fluffy	 Knitting	 Layers	 Thin material	 Fabric	 Velcro
Bracing 	 Elastic Band	 Metal	 3D Print	 Hidden seam	 Brace	 Metal

Combining the elements

After sketching on the different elements separately, I started to combine them to a new product where I focused on highlighting different functions. Sketching both digitally and traditionally. This technique helped me start the process with a creative mind, opening up for different solutions to the set task.

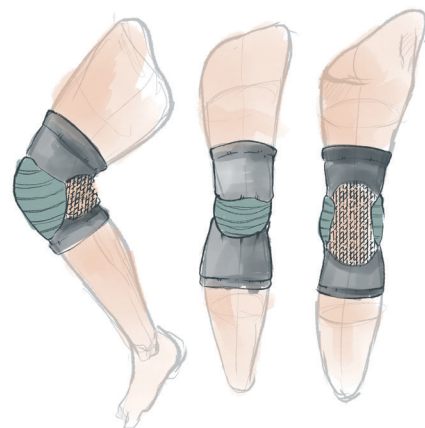
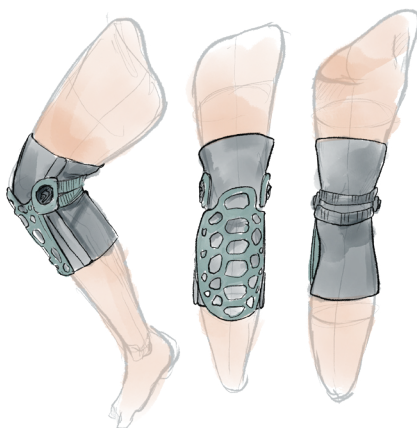
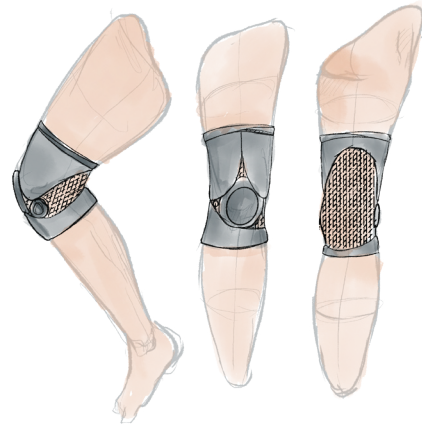

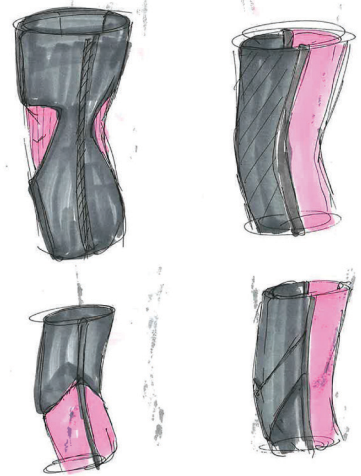
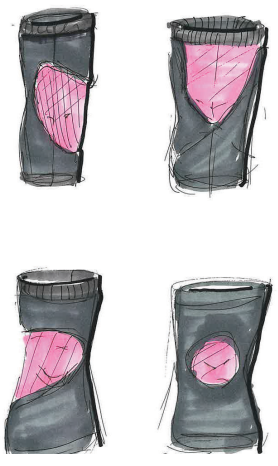
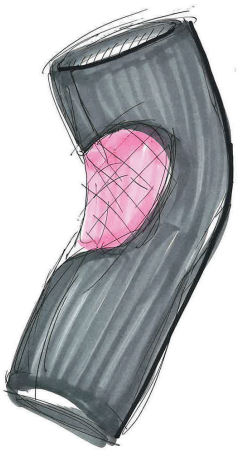
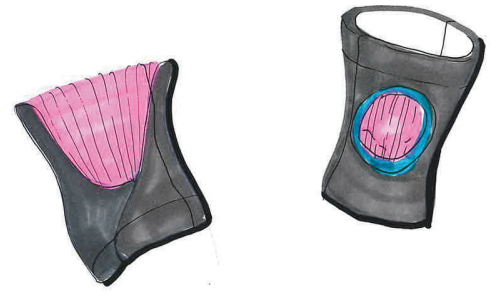

3D Print

3D Print



Adjustable Strap

3D Print



Cut fabric



1.

2.

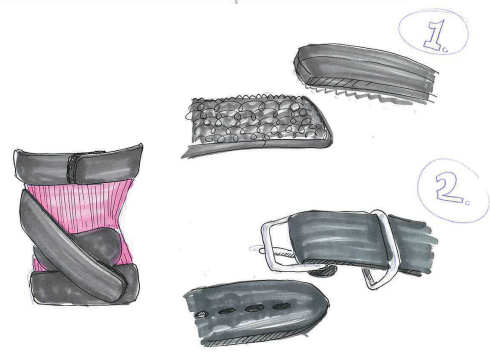

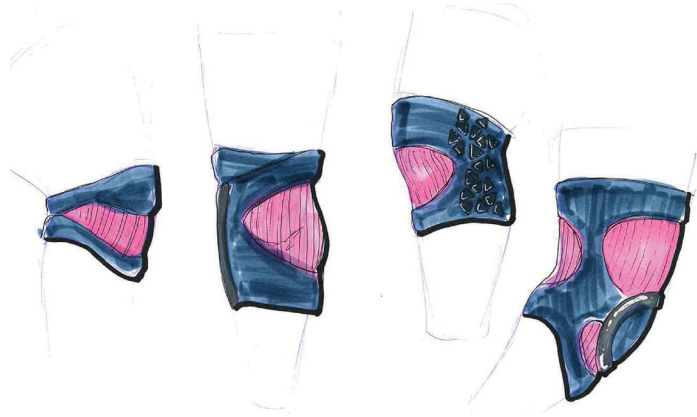
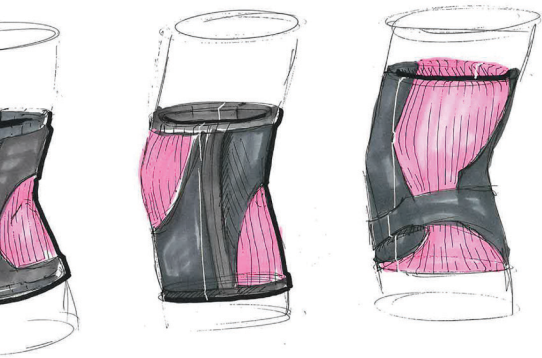

3 D Print
on fabric



Early on I got inspired by the concept of having 3D print together with fabric as a solution.

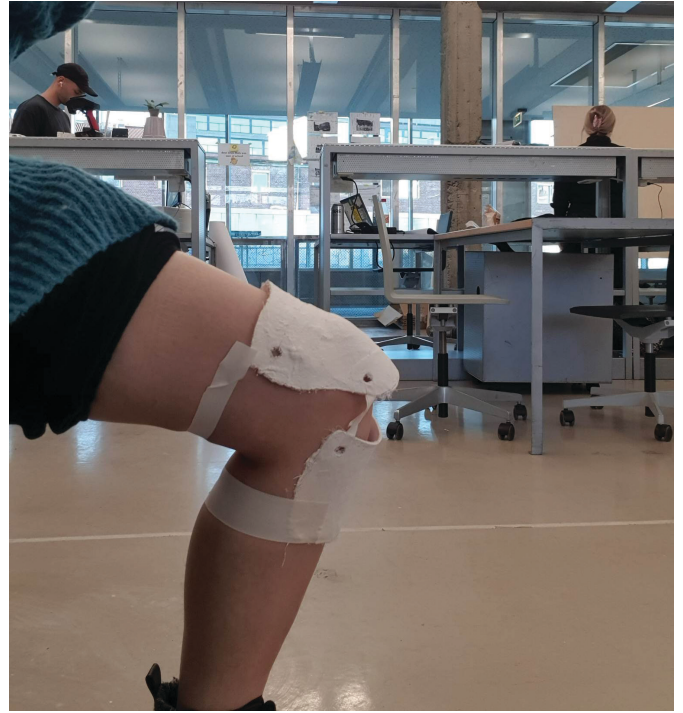
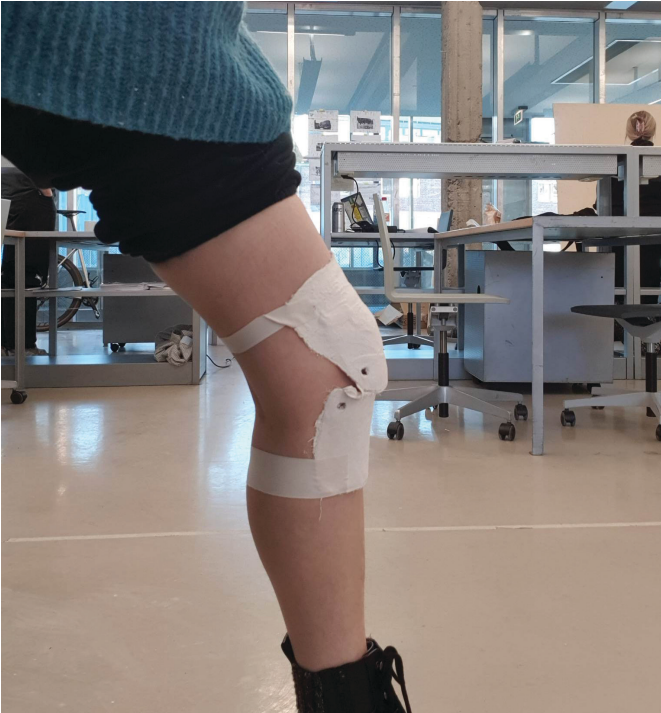

Playing with plaster

One of the first materials I tried out was plaster, since this was a quick way to get a desired 3D shape. I used my own knees as a mold which resulted in a snug fit, I could play around with.

My main inspiration for figuring out how a movable shell could function was using biomimicry. The animal I took inspiration from was the armadillo. Their protective shell on their back is a series of

plates overlapping themselves, giving it a harder exterior but still allowing lots of movement.

When I was cutting into the plaster I tried to mimic the armadillo's backplates. However during these tests I learned that breaking up the surfaces into smaller parts will lead to a weakening effect in the energy absorption. [19]





I experimented further with plaster, creating a cast of my knee which served as a foundation for producing simple models. Through this process, I tested various dimensions and employed the cast as a general tool to evaluate the visual appeal of the designs.



Using digital tools for sketching

Using an AI tool, I made it produce visual ideas of what winter sports knee pads could look like. My goal during this process was to test out its potential for ideating what a knee pad would look like if it was targeted towards winter. A common theme I saw while generating images was that most of the proposed ideas were thin and fitted to the knee. Looking more like knee socks with visual elements where the knee joint would be.

Another form of digital sketching method I did was a Franken sketch. This technique means that you take components from similar products and combine them in an image editing program. Almost making a collage that can mimic a finished product. This gives a rough idea of what a final product can look like.

This process inspired me to explore a more bubbly approach for the knee pad, and not just look at the hard shells and knee sock direction I explored previously.



Playing with shapes

During my process I felt, I needed to take a step back from ideation, and look more at the main shape and structure of the product. Now that I started to get a better idea of what qualities were required, I could test out if there was any room to push and pull the shape. The shape would still have to be quite confined to the shape of the knee.



Sketching out ideas for later testing

I began to find it rather important that I test out the comfort of the stretchy parts of the fabric. This material was the part of the product that would allow most movement. I wanted to test out how different shapes would influence the fit of the final product. I began sketching out patterns, I planned to cut out in fabric later. My intention was that this process would give me a direction for what the final main shapes of the product should be.



Front side:

As I examined the front of the knee pad, I found myself grappling with a crucial design decision. Specifically, I was uncertain whether to prioritize a padded knee pad or one that utilized elastic bands. This was a critical choice as it would significantly impact the overall comfort and fit of the knee pad. I took some time to weigh the pros and cons of each option, carefully considering factors such as the level of protection offered, the range of motion it permitted, and the ease of use. Ultimately, I decided that the best approach would be to experiment with both styles and determine which one would be the most effective in meeting the design goals.

Back side:

When I worked on the back side of the knee pad, I kept the medical knee braces in mind, as inspiration. By doing this, I was able to glean insights into the most effective ways to structure the back side of the knee pad, ensuring that it would be both functional and comfortable to wear. Here I also sketched out where I should prioritize more stretchy material.

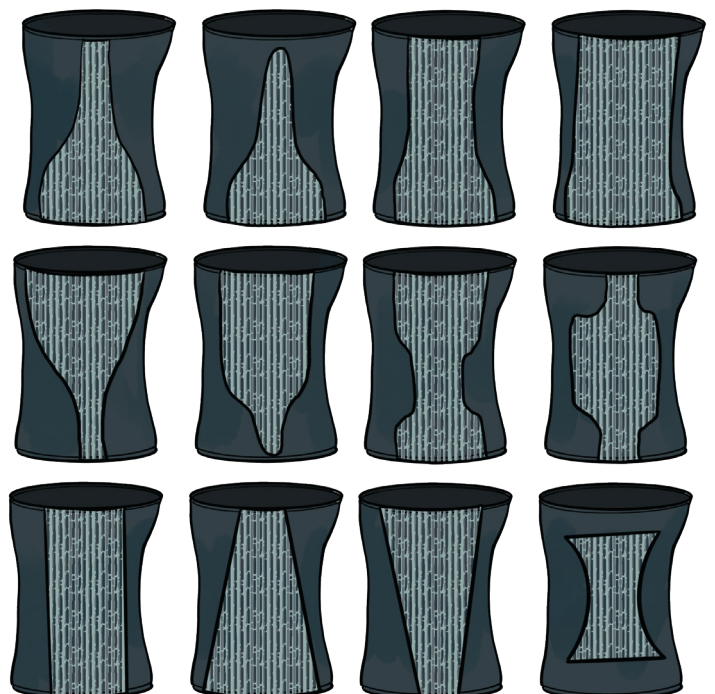

Looking at different ways of keeping the knee pad in place

Next I needed to figure out what kind of mechanisms, I could use in my product to keep it in place on the knee. To do this I first drew out what the most common mechanisms were. During this process I had questions such as 'should the product be able to fully open or just be a tube?' and 'is there an unconventional method that could be more fitting?' in mind.

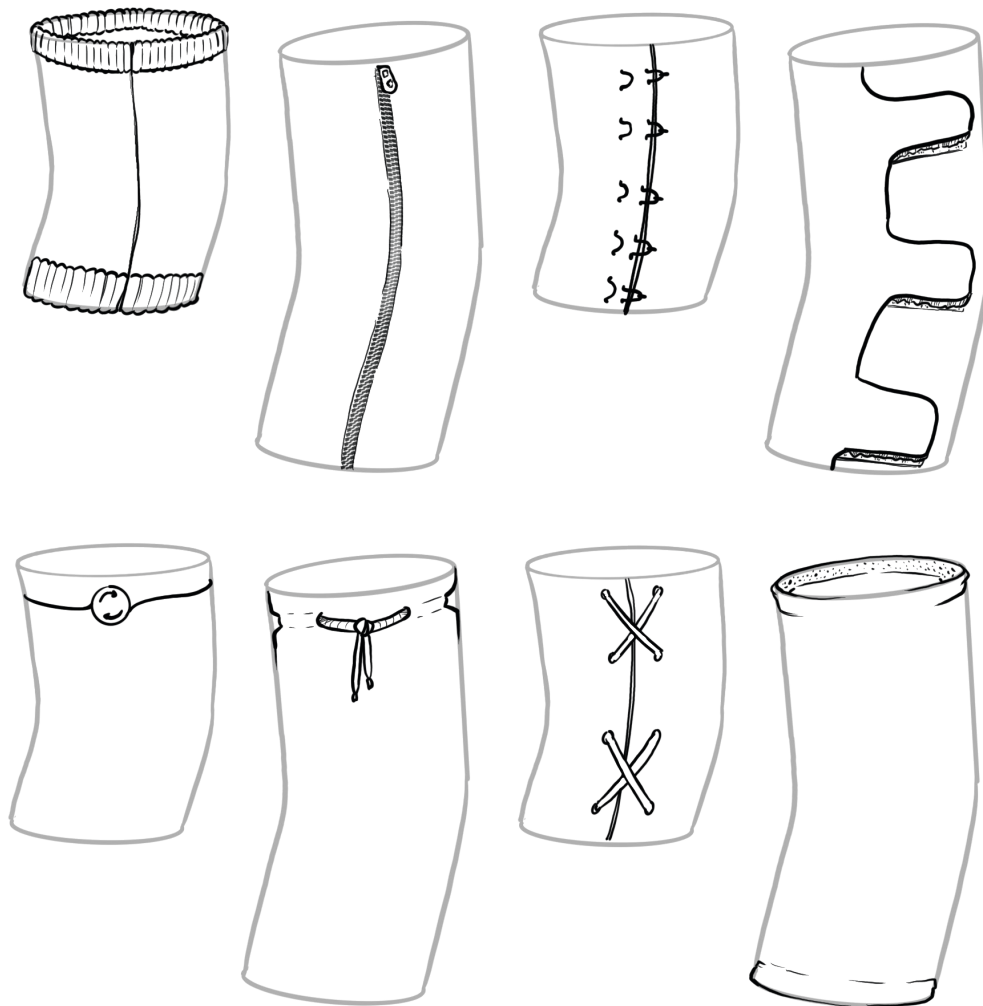

3D print on fabric

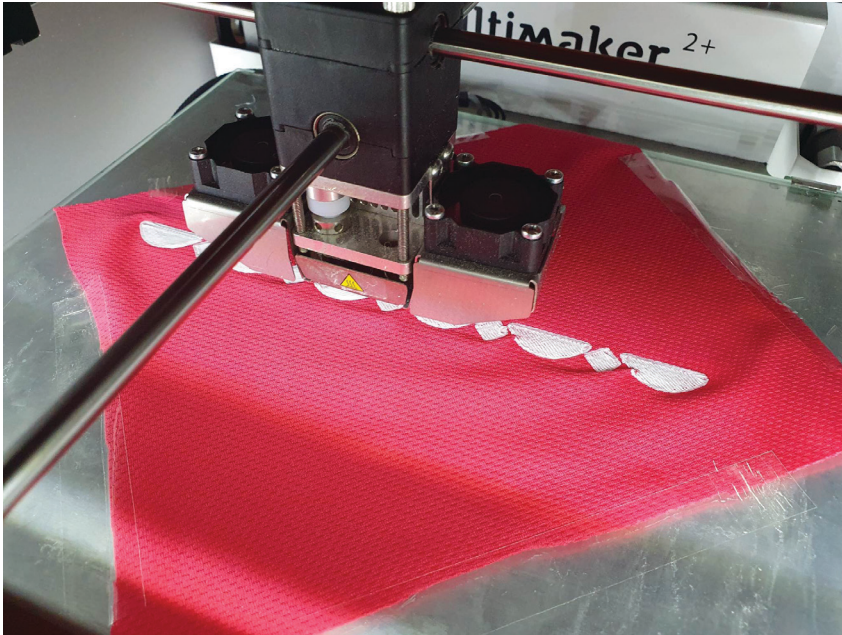

During the concept development I knew I wanted to incorporate 3D printing technology into my product. I was heavily inspired by a previous project regarding big scale 3D printing, this project reflects that.

Something I learned during this process, is that the textile used for this needs to either have a rougher surface for the plastic to adhere to, or it should be mesh so that the plastic adheres to itself. To get the desired effect I was looking for (preventing movement in one axis only), I had to print on

rigid fabric. Stretchy material is too moveable and would lessen the effect. Additionally the printed shape needed to not be too protruding or feel lumpy for the user.

The plastic material needed a certain thickness to have any effect. Therefore I landed on each piece of the exoskeleton having a thickness of 5mm for now. This would give it a slimmer appearance, but still offer working results. Though this should have further testing to refine the thickness for optimal effect and comfort.

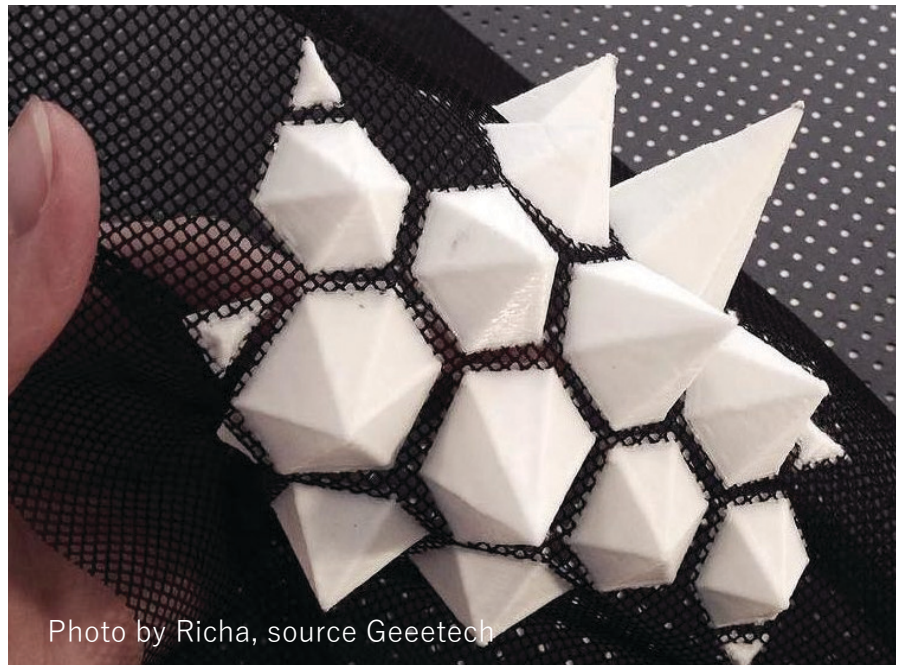
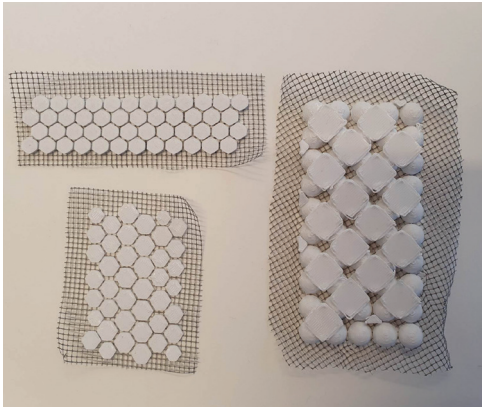
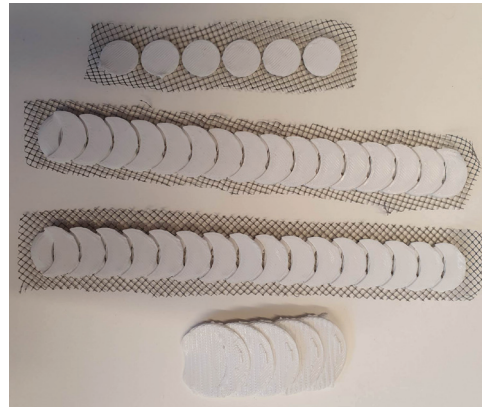

Photo by Richa, source Geeetech

Looking at hexagonal shapes



Rounded overlapping shapes making a spine



Exploring overlapping spinal shapes

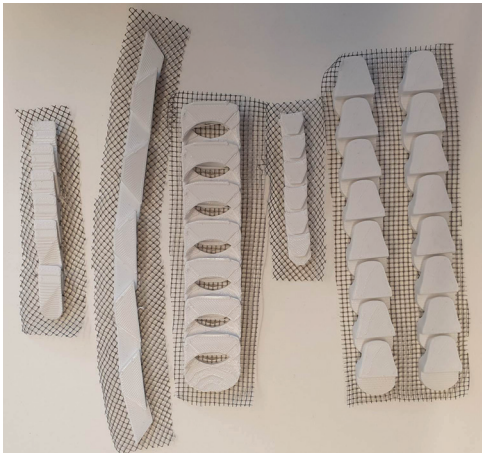

Testing out on stretchy material



Trying in incorporate mountain shapes into the print



Looking into new ways of making the joints

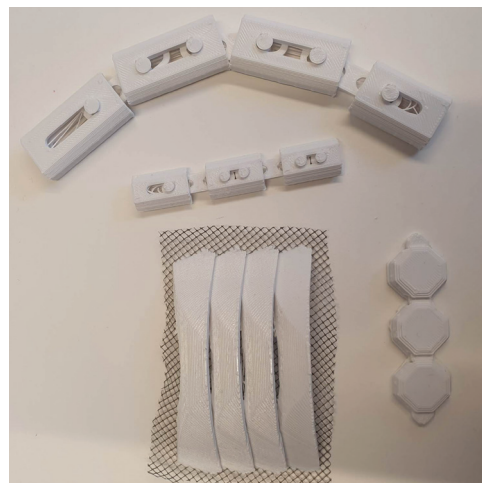

My 3D printing exploration journey





Workshops



Idea generating

I found myself getting stuck drawing the same concepts repeatedly, therefore I decided to host workshops. Through these workshops, I gathered more input and fresh ideas that I could implement in my own design.

I started the workshop by giving each of the participants a paper where they did a similar technique as I did previously, by dividing the object (a knee pad) into each of its components. This was to warm up their creative process. Further I gave them a list of different adjectives I wanted them to implement into a knee pad. This is a technique called forced relation. After sketching up some ideas, they had to draw on each other's concepts to further develop them.



Knitting

Another method I wanted to look into was 3D knitting. To get a better idea of how this could work, I decided on knitting my own knee tube. This helped me get a feel of the comfort, how knitting could be implemented and how different firmness in the knit would influence the final product.

Because of the complex nature of 3D knitting technology, working out how to implement it into my project would require more expertise on the field. Experts in this field unfortunately did not have time for a visit during this project.





5cm

6 cm

7 cm

Paper prototyping

When making my paper mockup, it was important to figure out how far the knee brace could go before it would be in the way of a ski boot. So to get a better idea of how long down I could go, I decided to use an actual ski boot to estimate the length down.

After talking with Sweet Protection, they gave me a guide showing how far above the knee cap I had to go. The general span is between 5 cm to 10 cm. Sweet Protection recommended working between 8-10 cm above the knee. This made me choose for my product to cover 9 cm above the kneecap and 10 cm below, making the final product a size of approximately 21-22 cm for a size medium.

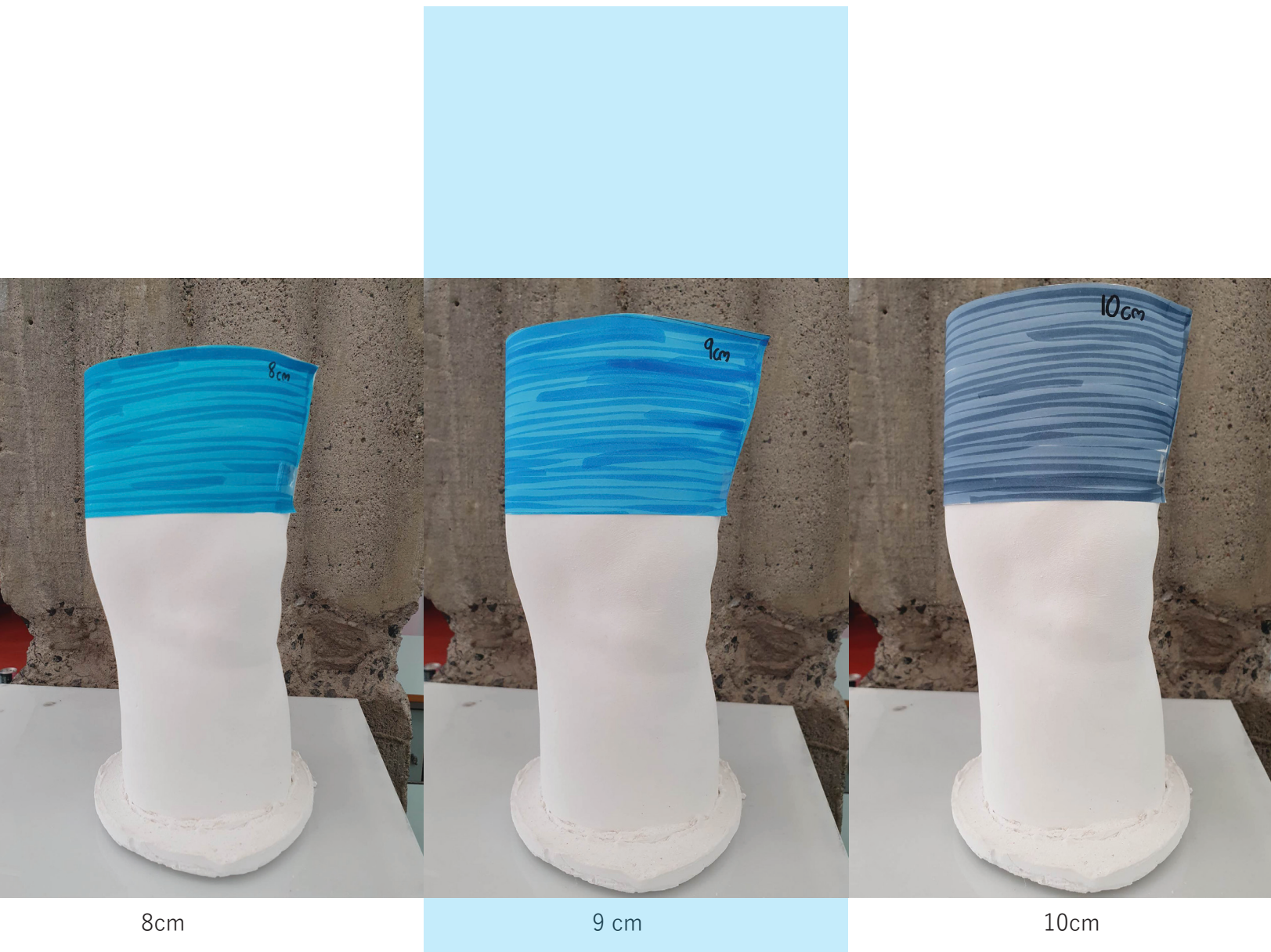

Proof of concept

What was used

Following a conversation with Ståle Møller from Sweet Protection, we mutually decided that, testing the 3D print's efficiency in withstanding force, was necessary.

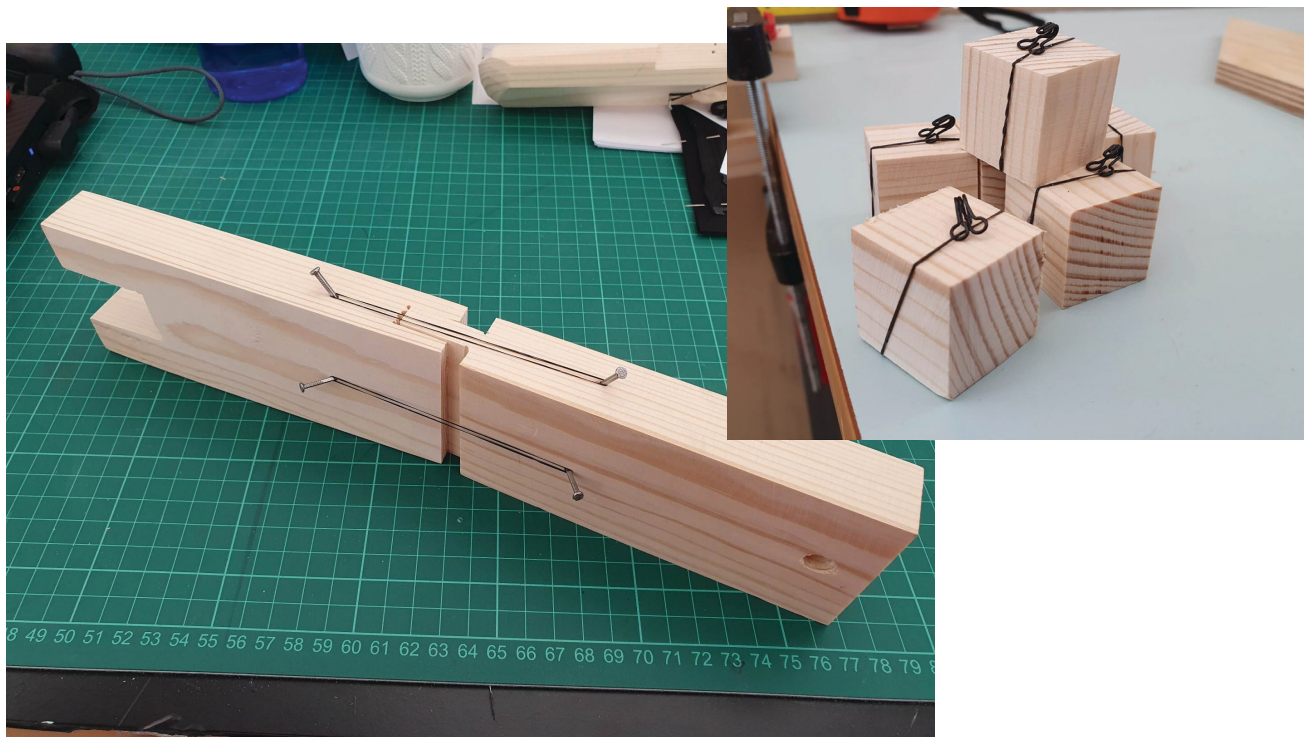

Therefore I made a simple rig to simulate a knee joint, to test out if my 3D exoskeleton solution had any effect. The rig consisted of a joint made of wood with elastic bands to work as the ligaments. The aim of this test was to see if the 3D print restricted the movement in the undesired direction. I used gravity and 8 wooden blocks, each weighing 8 grams.

My Approach to Testing

First I performed a test without the exoskeleton, where I hung more and more blocks on the edge of the knee joint to simulate pressure. I used a horizontal measuring tape to see how much the joint moved with the added weight. Afterward I did the same procedure with the exoskeleton attached to the underside of the simulated joint. The second test with exoskeleton yielded marginally better results.

All in all I carried out the test about five times, each time yielding similar results. Through this test I learned that the 3D printed exoskeleton method had potential, but would need more tweaking and choosing the right textile material is very important.

	With	With out
0	5	7
1	6	8
2	7	10
3	8	12
4	10	13
5	11	15
6	12	17

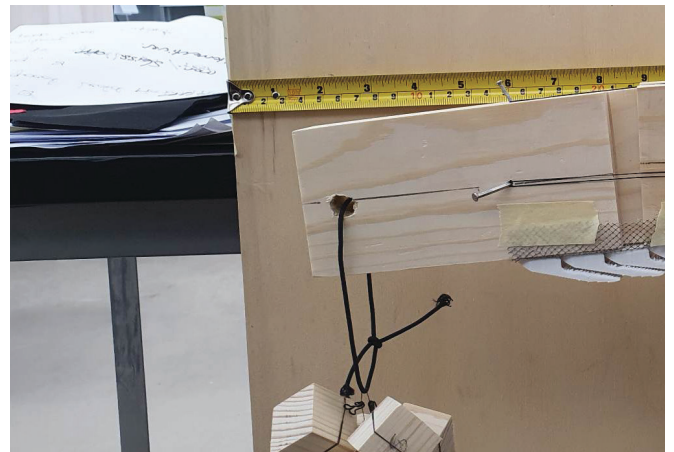
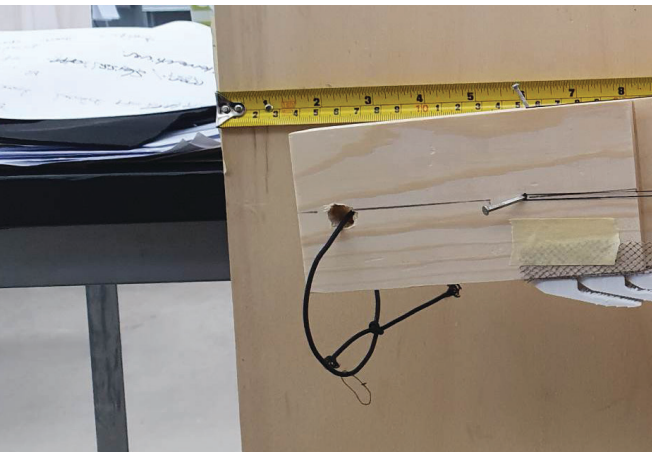
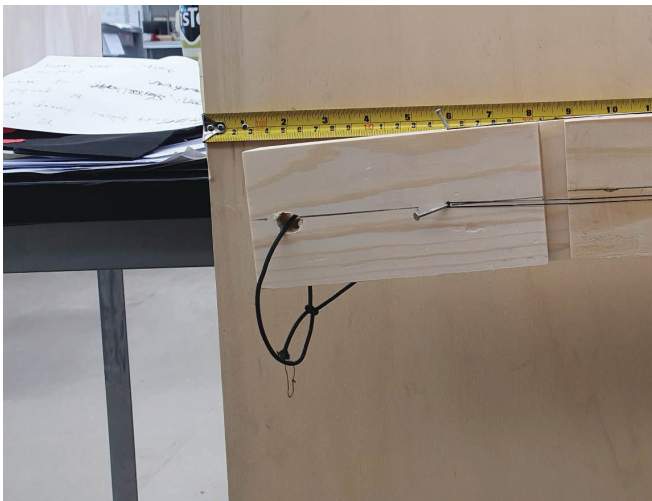

Mockups

As a result of my ideation phase, I generated around 10 basic mockups, each intended to explore a distinct aspect or feature.





User testing

User testing

Now that I had made some simple models and the weather was becoming warmer, I decided it was time for some user testing. I was lucky enough to get one of my friends who snowboards to test out one of the models I had the most faith in.

The model I wanted to test used my preferred material. It also had the back shape I felt gave the most comfortable fit, and I used an elastic band at the top and bottom to keep the knee pad in place.

I received some really good feedback from this test:

- They were so good!
- Feels warm and nice!
- Feels safe and helps a little when you fall.
- It works well when walking up.





Photo by Bryan Walker, source Unsplash



User Update

Later on I got an update from my user, talking about how their knee looked after a trip without the knee pad:

“I should have used your knee pad!”

“Jeg burde ha tatt din beskyttelse!”

“Because I keep falling on my front knee!”

Fordi jeg faller alltid på kne som jeg har foran!



MORE SKETCHING!

Now that I had a pretty good idea of what I wanted to make and how I needed to shape it I started to finalize some ideas I could call concepts.

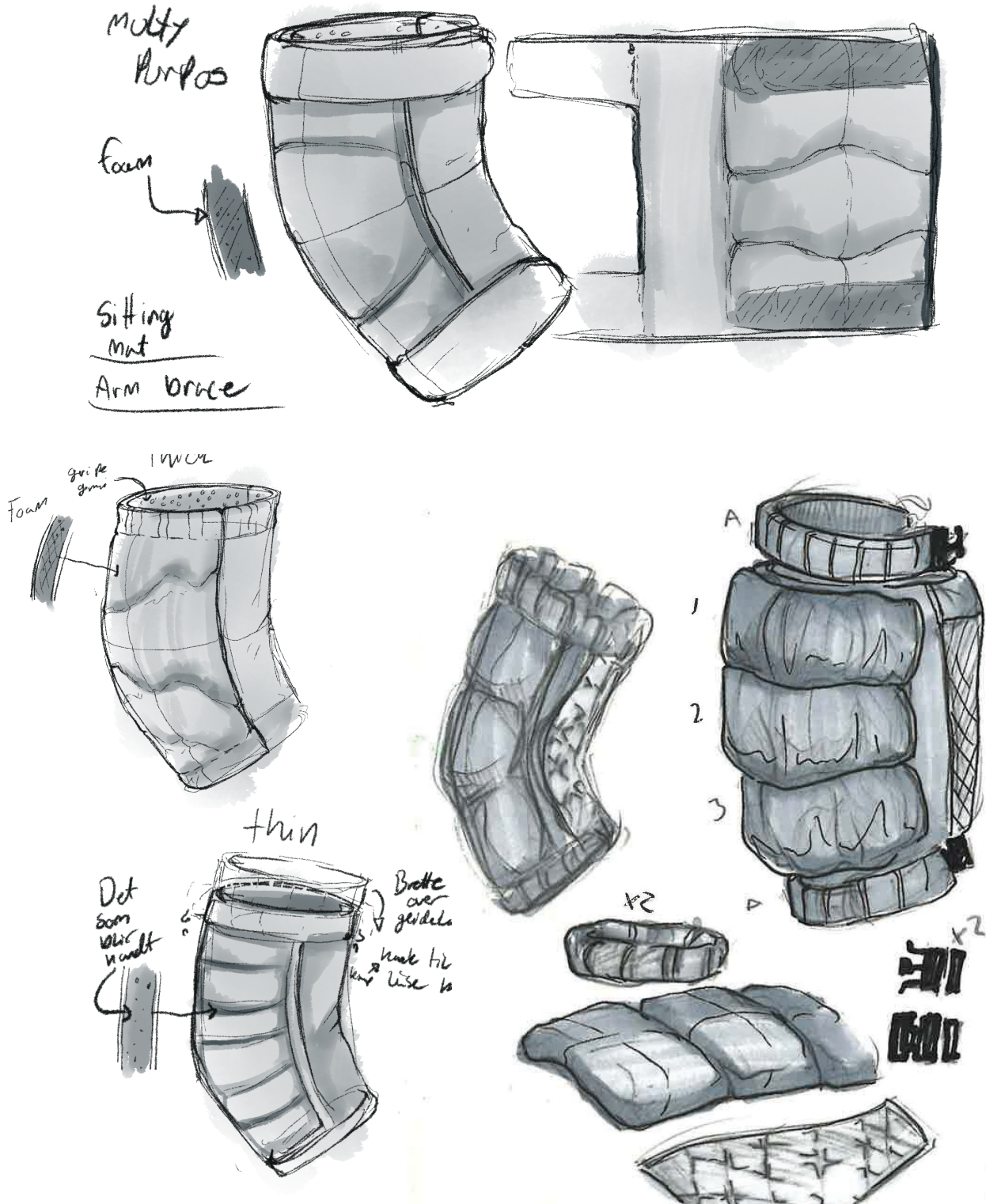

3 CONCEPTS

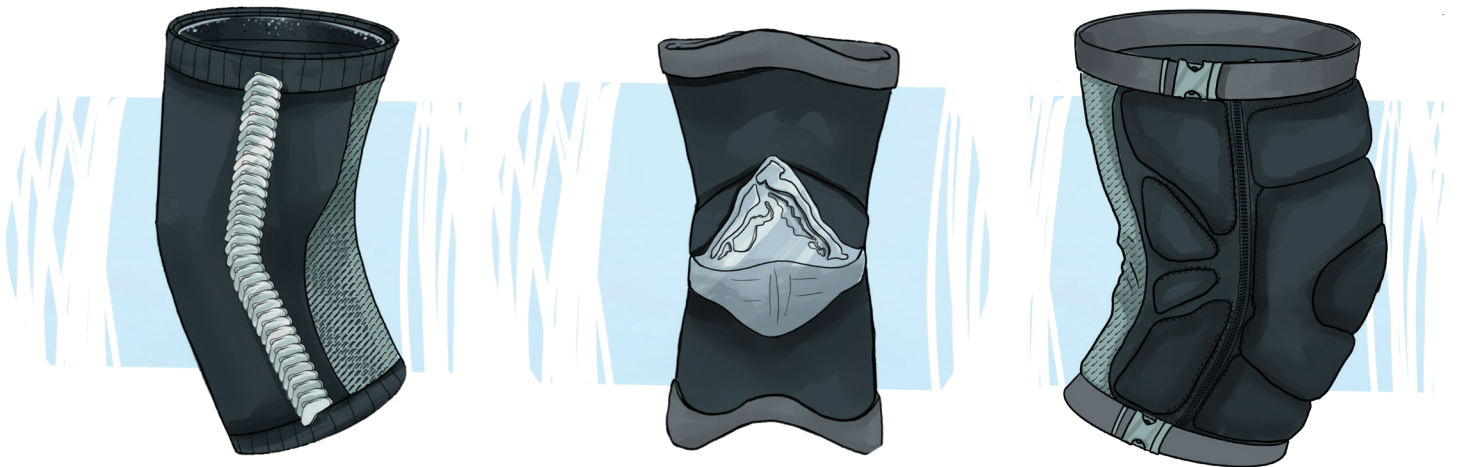

With a clear understanding of the direction I wanted to take and the necessary design specifications, I began to solidify my ideas into concrete concepts. I ultimately explored three distinct directions, each corresponding to one of the user groups I had originally studied.

Although my goal at the outset of the project was to create a knee pad that could address the common concerns shared among all groups, I was faced with the question: 'can I make the perfect knee pad?' My answer to this was no; the different winter sport activities require different types of protection. I figured that in this case it would be better to specialize, than generalize.

OnHike

OnHike is a knee pad for hiking up a mountain with the intention of skiing down. It is meant to be multifunctional throughout the trip. Since you can just clip it on somewhere or roll it up, it should be very easy to bring with you. Once the hiker has reached their destination or wish to take a break, OnHike can be used as a seat, preventing the user from getting cold. Finally once it is time to go down the mountain, OnHike is to be worn on the knee, keeping it warm and providing cushioning for potential impacts. It is meant to be worn on the outermost layer of clothing.



OnHike

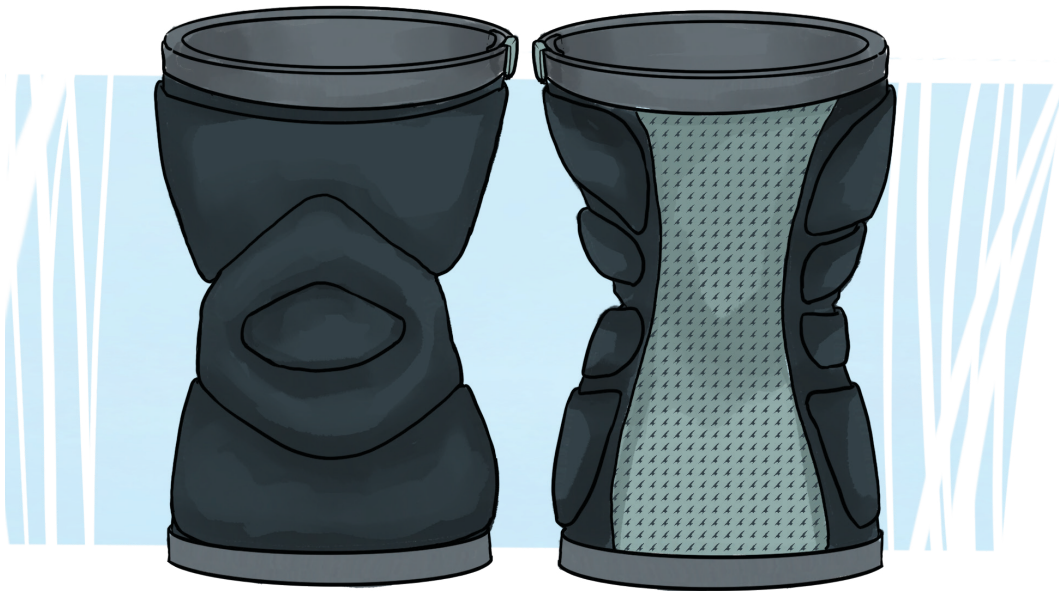

Must	Should	Can
Easy to put on and off	No protruding parts that can get hooked on things.	Easy to fix
Comfort	Is located on the outer layer of the clothes	Affordable
Doesn't slide down	Easy to take with you	Visually hints towards winter sports
Retains warmth		Multiple functions

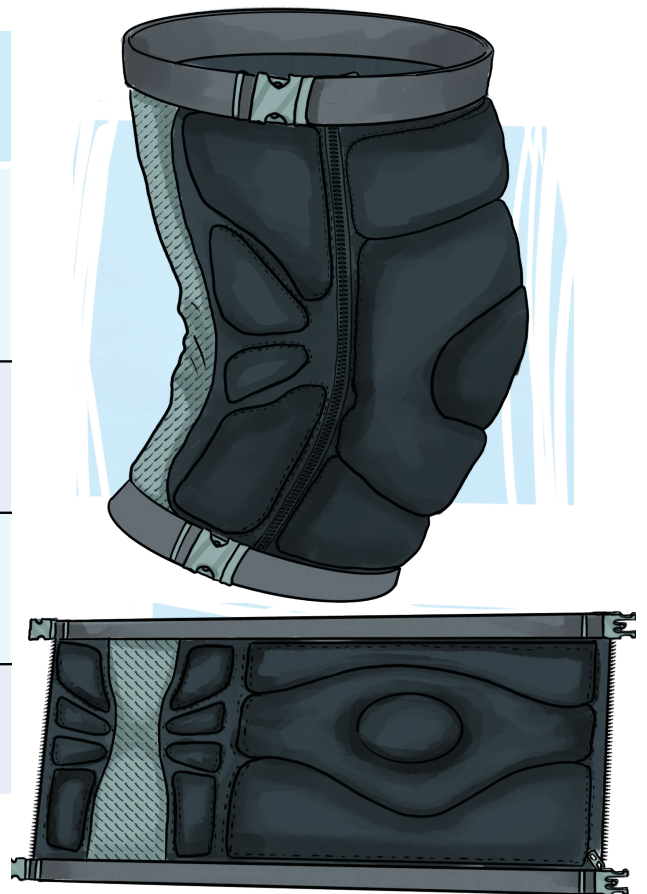

CONCEPT 1

SnowBrace

SnowBrace is an impact focused knee pad, intended for use in snow parks with lots of obstacles and higher chances for impact injuries. This knee pad is meant to be worn on the inner layer of clothing to provide best results of impact absorption. This particular knee pad is very similar to common knee protection.



SnowBrace

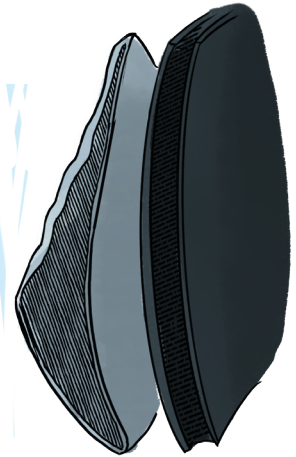
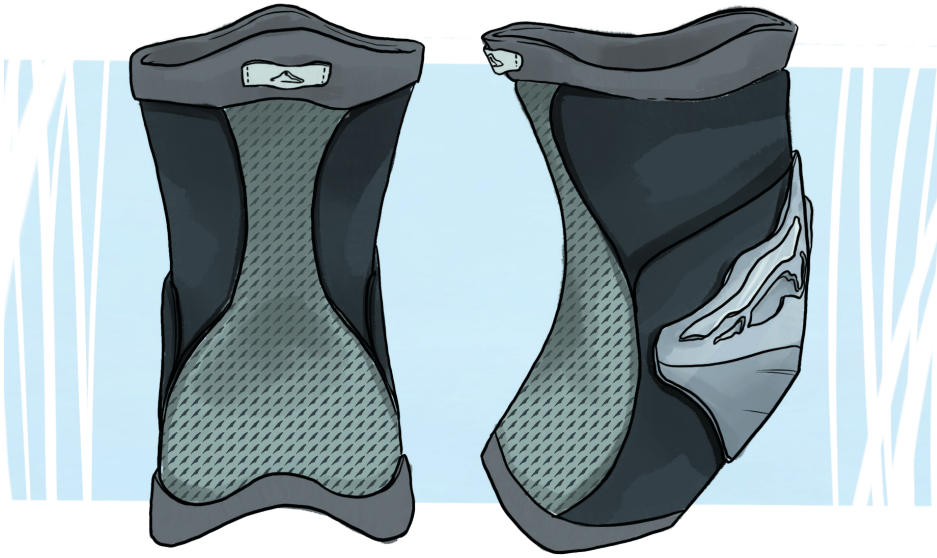

Must	Should	Can
Reduce impact injuris	Easy to put on	Easy to fix
Comfort	Is located on the inner layer of the clothes	Affordable
Doesn't slide down	Low profile	Visually hints towards winter sports
Retains warmth		Looks trustworthy
Breathes		

CONCEPT 2

NoTwist

NoTwist is a knee brace that specializes in preventing MCL tears. Its secondary function is to keep the knee warm during down time, such as lift rides. With the use of 3D printing technology, I have implemented exoskeletons on the sides of the knee joint. This will prevent a horizontal bending movement, lessening the risk of the knee joint jolting in an undesired direction. This knee pad is meant to be worn on the inner layer of clothing for optimal protection.



NoTwist

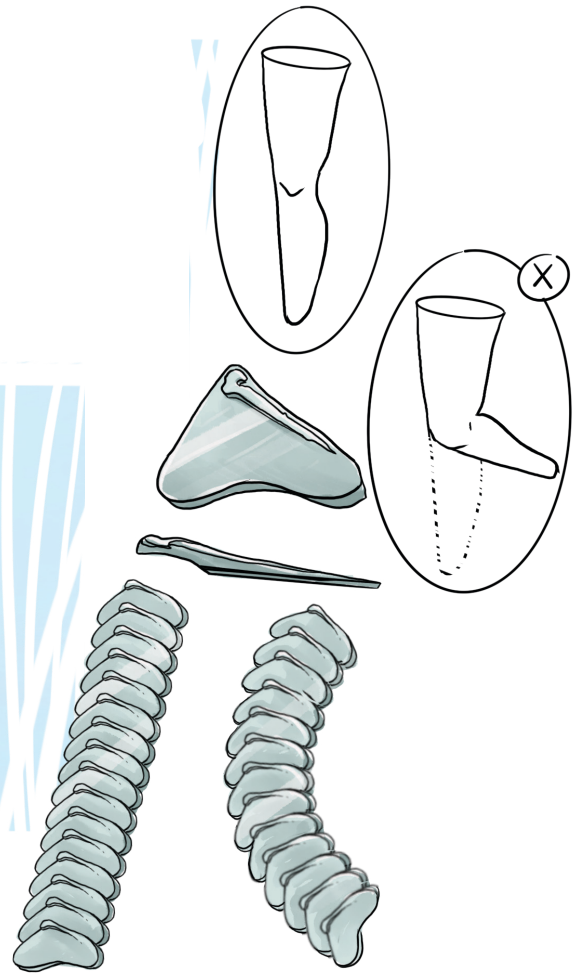
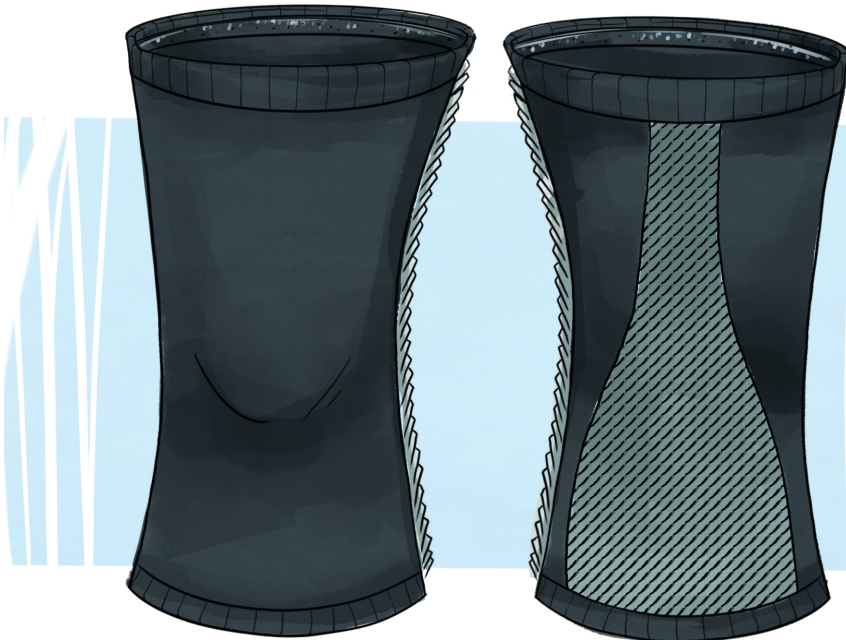

Must	Should	Can
Reduce MCL injuries	Easy to put on	Easy to fix
Comfort	Is located on the inner layer of the clothes	Affordable
Doesn't slide down	Low profile	Visually hints towards winter sports
Retains warmth		
Breathes		

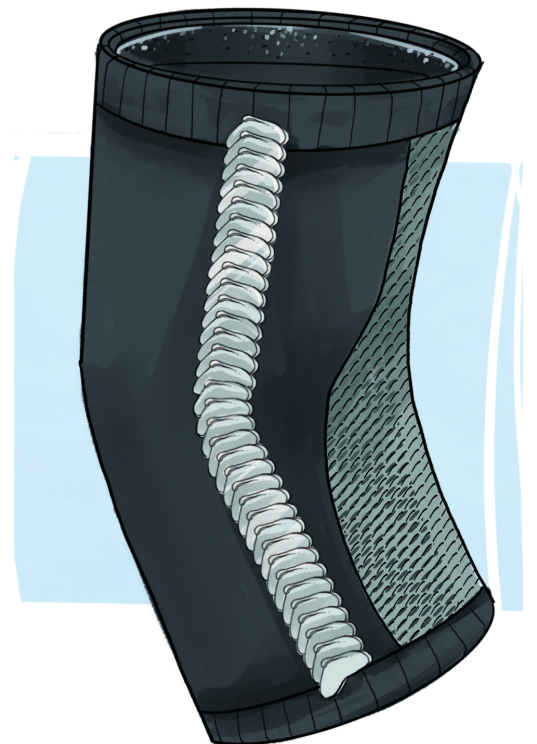

CONCEPT 3

REFINING CONCEPT

I decided to continue with NoTwist as my main concept, while bringing elements from SnowBrace into the final design. The reason for this is, I felt NoTwist was the product that answered to my project the most, but I saw potential in merging some of SnowBrace's elements in without them being the main focus. I started to sketch combinations of the two products looking at how they would look together.



During this process I also looked into to how the viscosity foam would lay inside the knee pad, but still be able to take it out for washing or repairs. I made an illustration demonstrating how the foam would lay inside a pocket, where it is accessible from the inside of the knee pad. While wearing the knee pad, the foam would be pressed against your leg so there is no risk of the foam sliding out while using it.

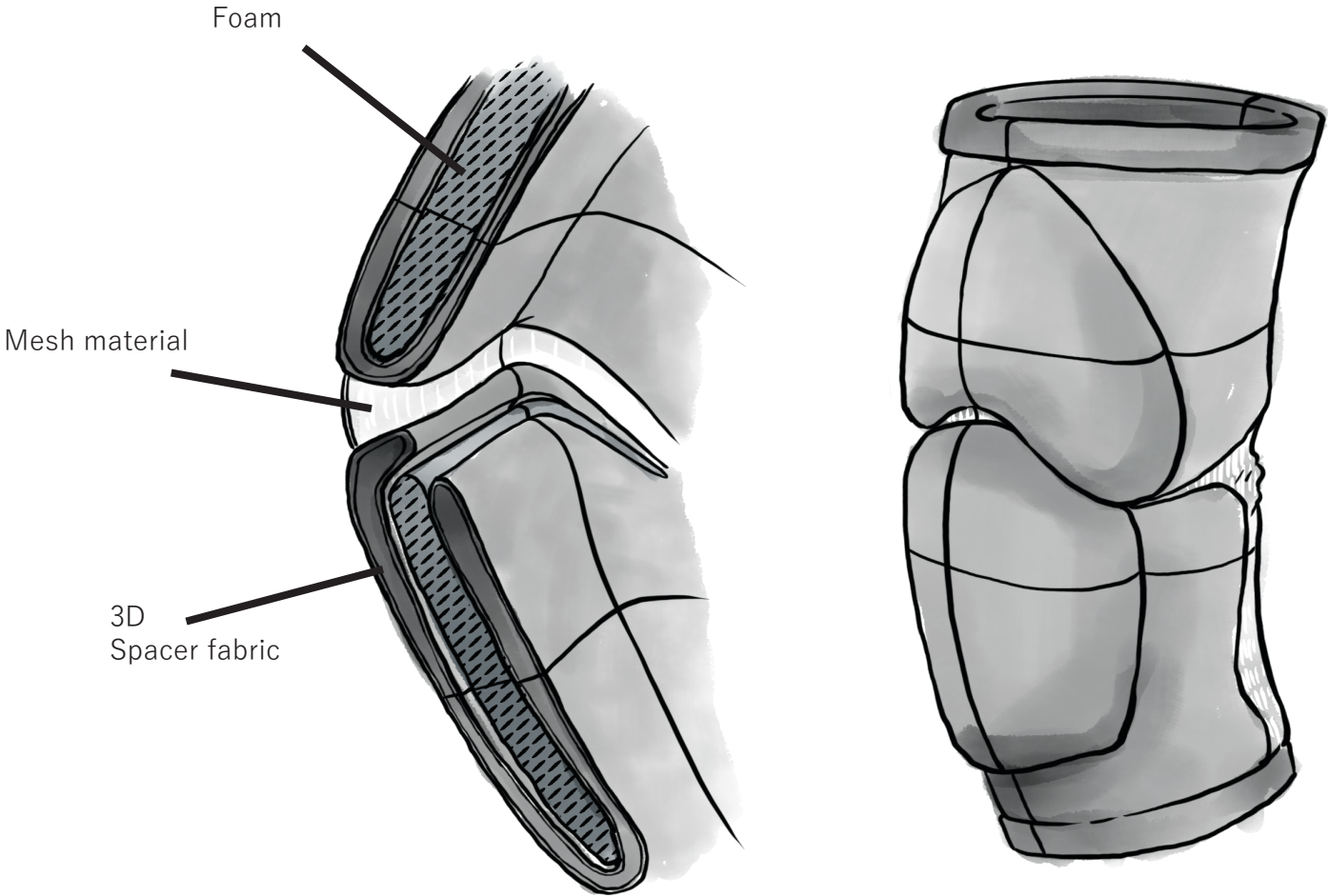

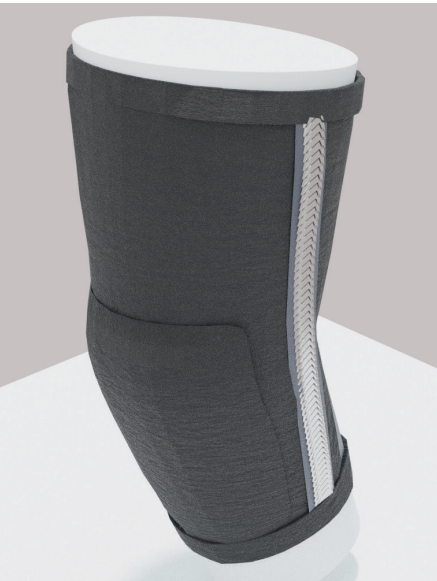
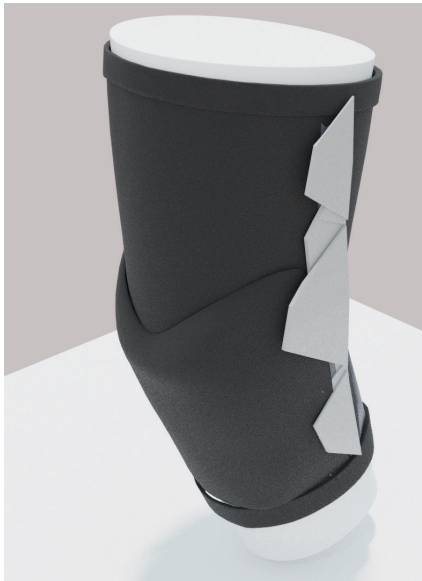

CAD as a sketching method

After working on some ideas on paper, I decided to build the knee pad up in a 3D space using Blender as my preferred 3D sculpting software. The reason I'm using Blender, is because it is a polygon based program. I find working with organic shapes and materials, like the knee and fabrics easier with Blender, than using programs that use parametric 3D software. While programs like that can provide more accuracy, they also make the model building process feel more stiff and time consuming.

With the use of CAD modeling I could easily test how different shapes and ideas would look on the same knee base. Using these models, I could figure out how I wanted to implement a logo of the mountain, and how I could utilize the seam in front for mobility. At the front of the knee pad there will be a mountain shape that follows the upper part of your kneecap. This mountain seam will allow for more mobility, while also using a graphical element that highlights the winter theme of the product.

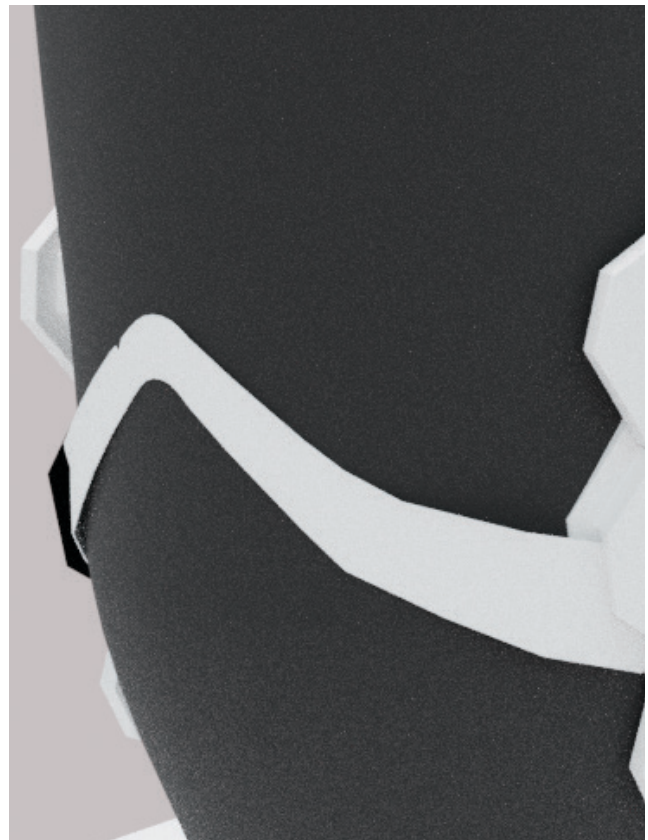

Second workshop

At this point I had yet to finalize the shape of the exoskeleton, and modeling the shapes and printing them would take too long. Therefore I decided to host another workshop where we used cardboard cutouts to make paper models and used hinges to see if there were any potential.

We ended up creating a design that looked like a mountain range when it was straight, and created a soft transition between the shapes when it was bent.



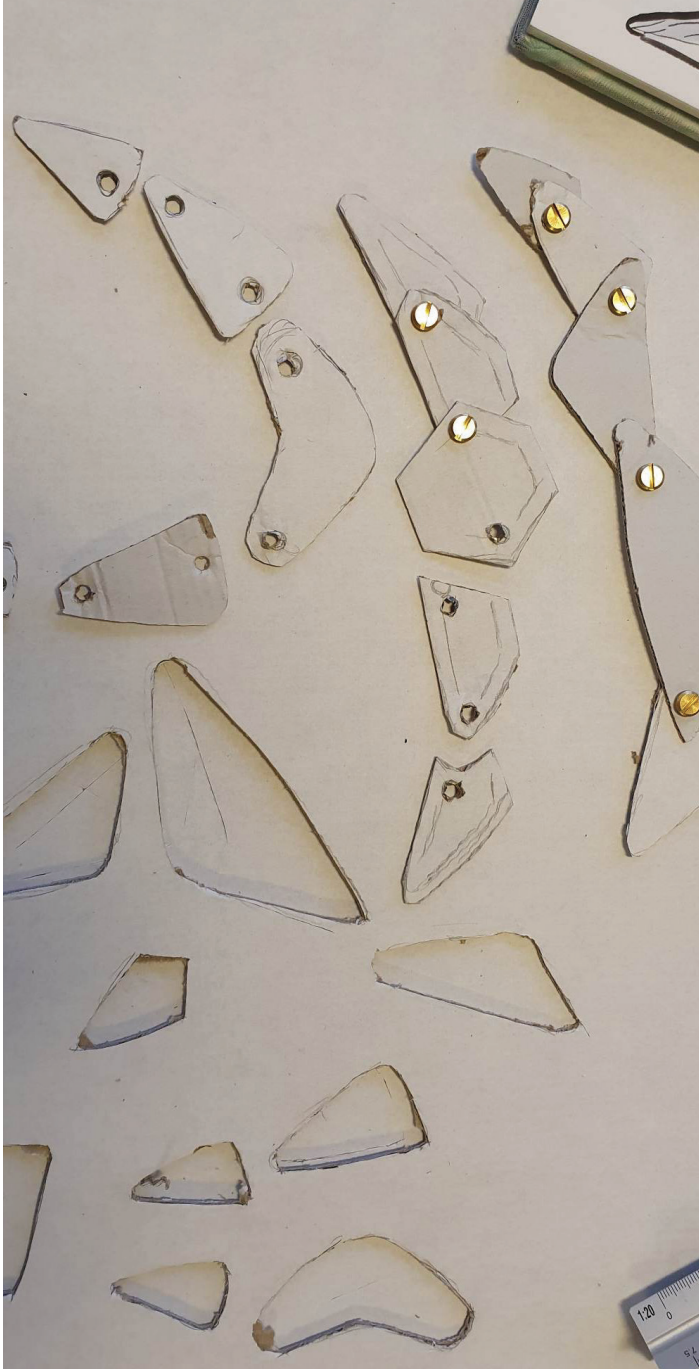

Talk with an expert

I went back to one of my previous medical experts to show them what I had thus far, and hear what they had to say about my product. During my initial research, the question of transferring forces from the knee to the hip had come up. This had been one of my concerns, so was keen on hearing what they had to say about it.

“It’s rather difficult to answer because of factors such as age and body weight. But generally the hip is a rather strong joint, so it will take a lot before you’ll get femoral neck fracture or the hip dislocated.”

“Hmm det er litt vanskelig å svare på for det kommer an på faktorer som alder og kroppsvekt. Men generelt er hoftelrådet et veldig sterkt ledd og det skal mye til før du får lårhalsbrudd eller at hofta går ut av ledd.”

Other than this they didn’t feel comfortable giving a statement on my product because of the lack of information on preventative gear for MCL injuries. They did however seem intrigued by my idea.

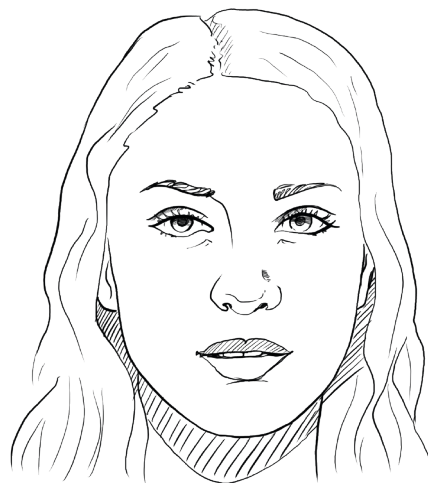

Chapter 4

FINAL CONCEPT

Making the final sewing pattern

I have designed a knee pad sewing pattern. The included patterns are the initial designs I intended for this project. It's important to note, that the measurements provided in the pattern are based on a size medium. If you need to adjust the measurements to fit a different size or specific body type, modifications may need to be made to the pattern.

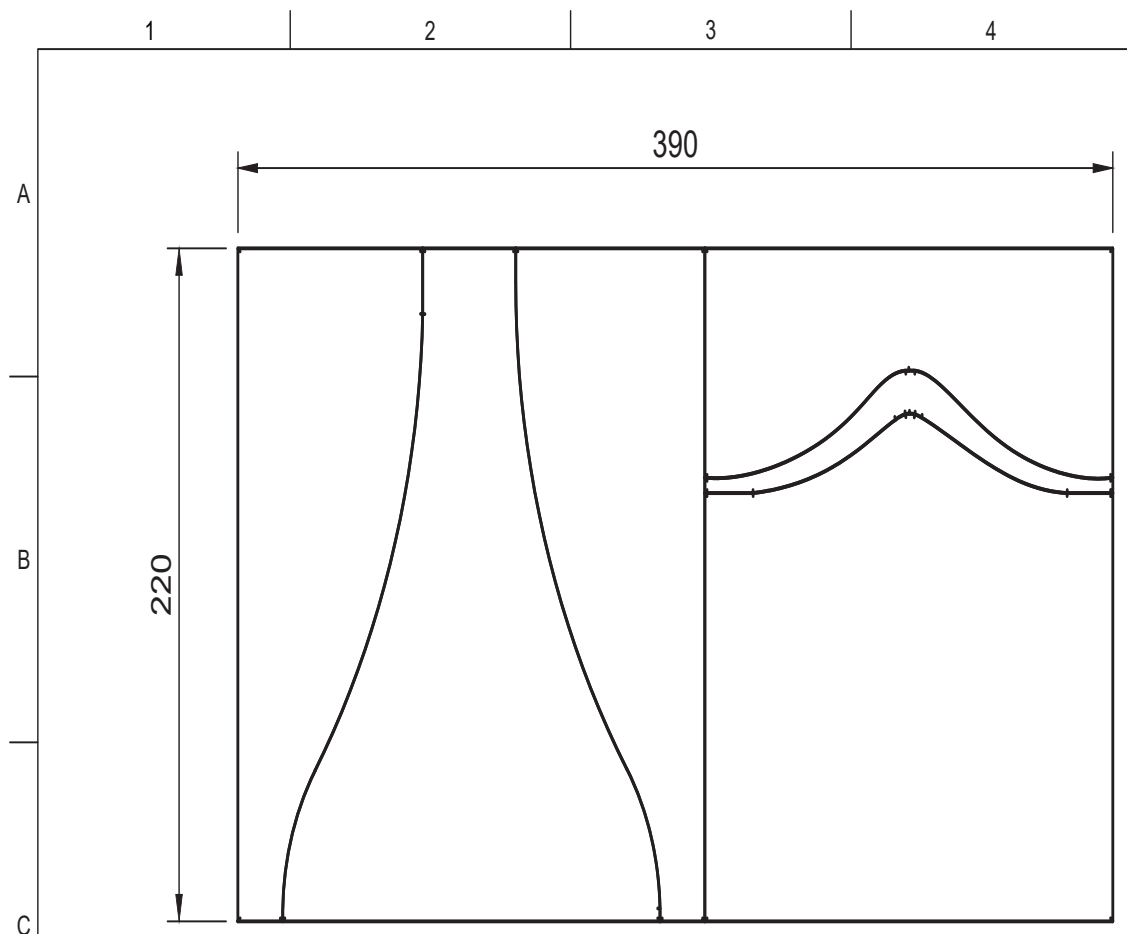

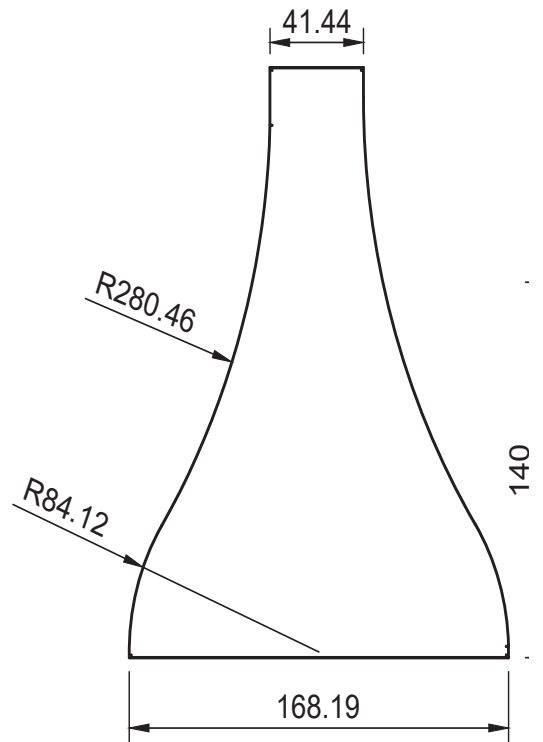
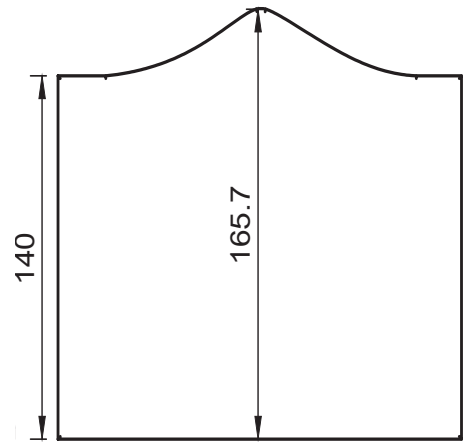
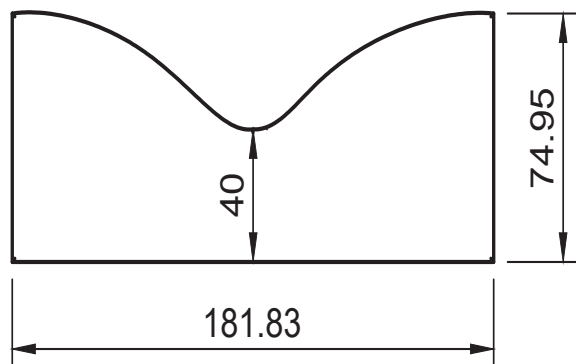
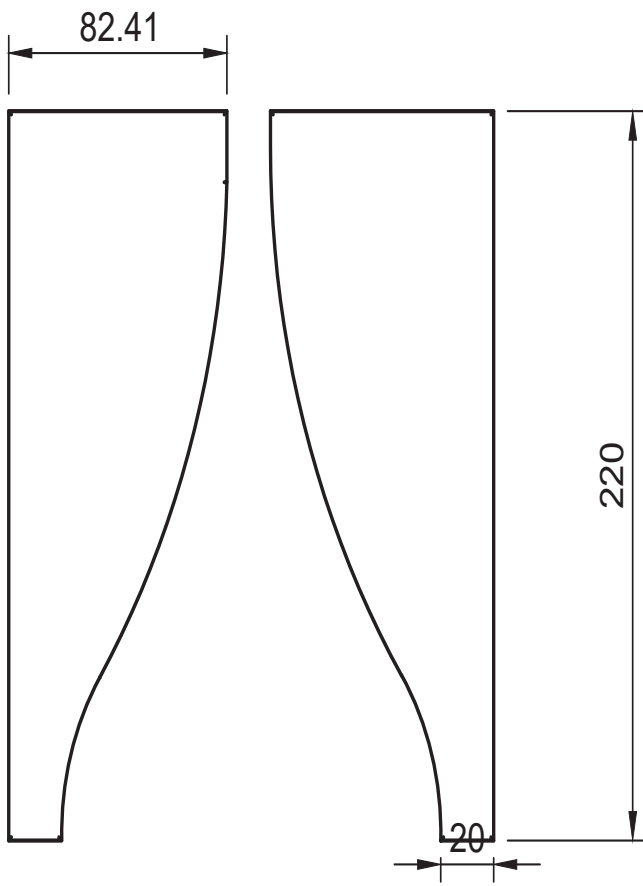
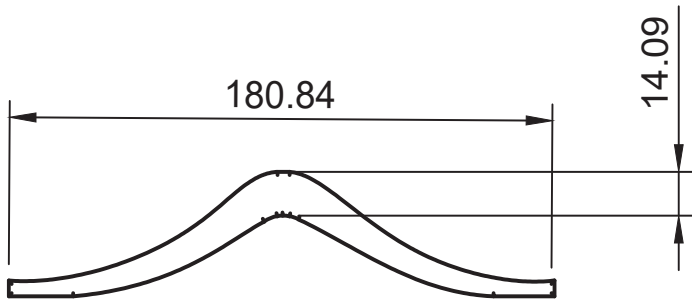

Drawing up the patterns

To transfer the sewing pattern onto my fabric, I used pattern paper and added an extra inch on the edges to allow for the seam.

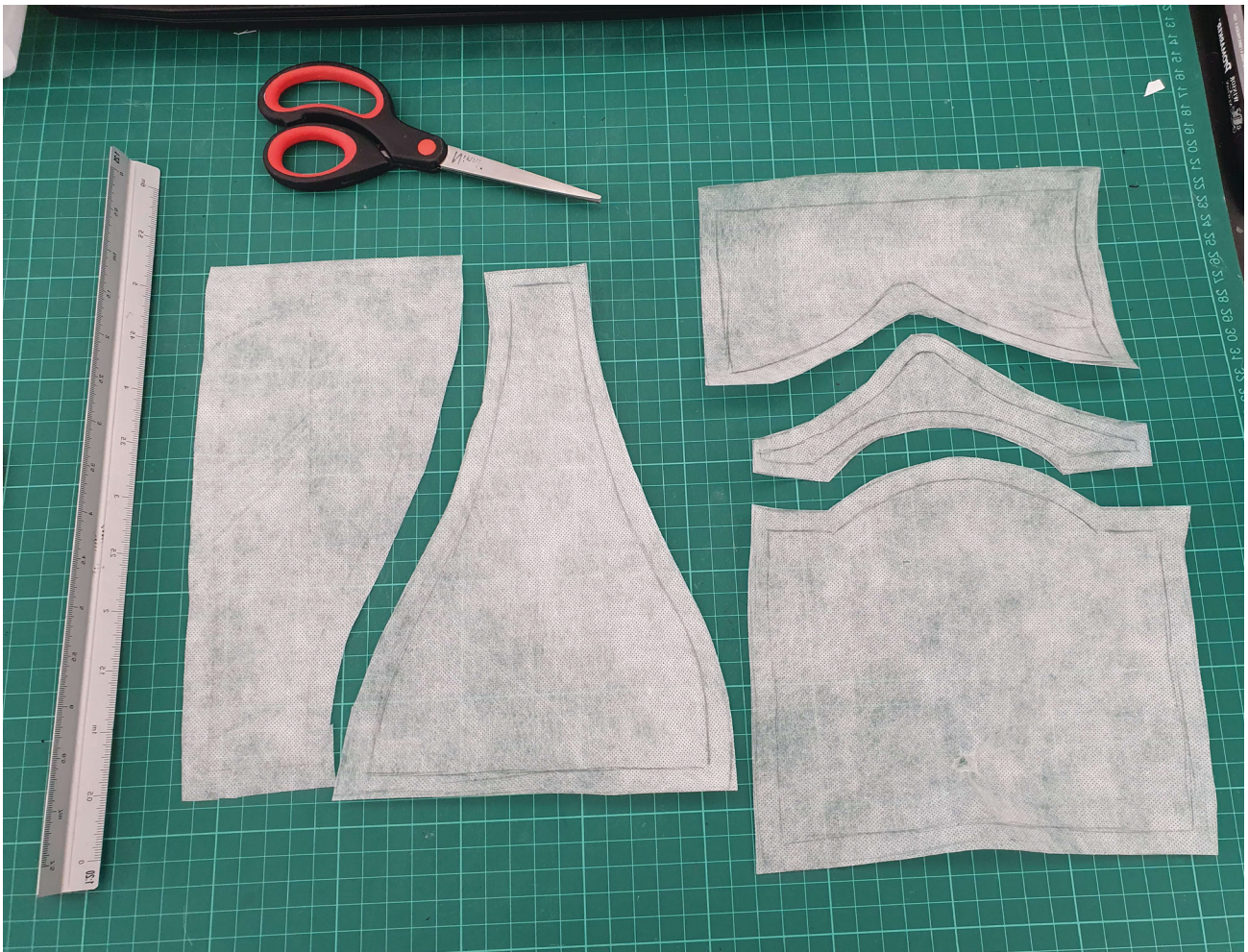

Sewing Pattern Test

After creating the initial sewing pattern for the knee pad, I tested it out and made a first draft to see if there were any areas that needed improvement. This allowed me to identify any potential issues, and make any necessary adjustments before moving on to the final version of the pattern. The pattern shown above is the updated version, that was created after implementing the necessary adjustments.



After modifying the initial pattern, I added an exoskeleton to enhance the knee pad's functionality. I used the first draft as a model to showcase the movement of the exoskeleton.

FINAL CONCEPT MODELL

My end goal for the final product was to have a sleek design, that gives off the feeling of safety and comfort. To achieve this, I opted for a natural color palette, drawing inspiration from Sweet Protection's collection and incorporating cold tones reminiscent of snow and chilly weather. Additionally, I chose to conceal the seams to create a smooth appearance and make the knee pad look more comfortable. This also created an effect similar to what you see on winter down jackets, while keeping the knee pad as slim as possible.



Detailing







Exoskeleton

While the exoskeleton is a key feature I wanted to showcase for this concept, I realized that it was important to have it covered to prevent entanglement with fabric when users put on or take off the product. Doing this I have greater confidence that the exoskeleton would be shielded from external forces, providing added protection.

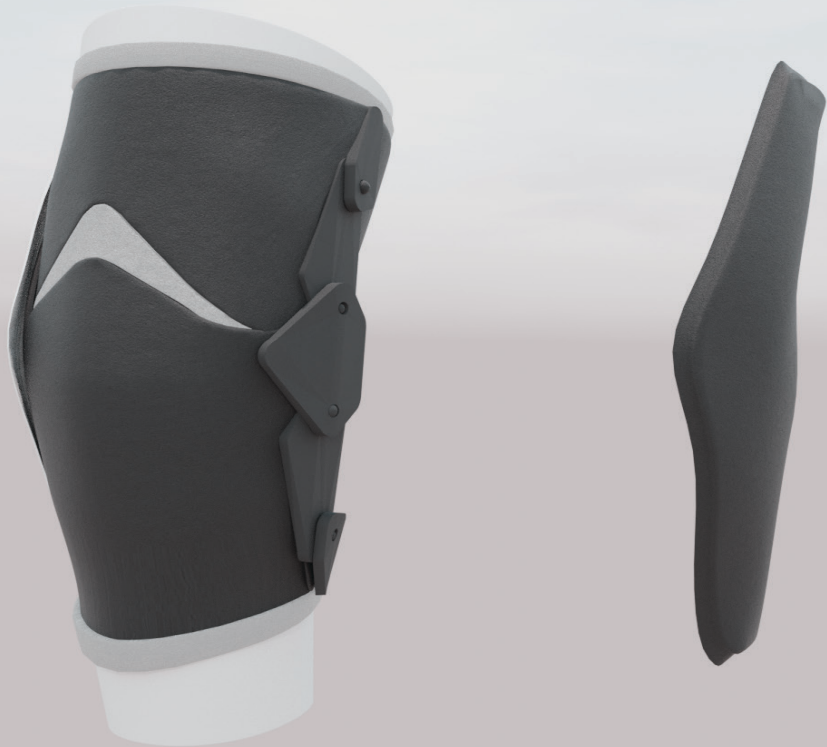

Front

Here you can see how the mesh fabric on the front provides greater flexibility for the knee, while also offering significant padding both in front and under the kneecap.

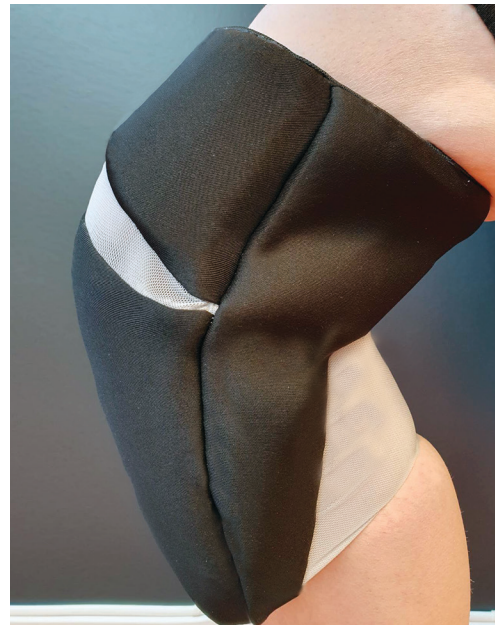

Back

The incorporation of a mesh material on the backside of the knee pad serves two purposes. Firstly, it enhances the wearer's range of motion by providing increased flexibility when bending the leg, thereby allowing for more fluid movements during physical activity. Secondly, the mesh material promotes air circulation around the knee area, which can help dissipate heat and moisture, providing a cooler and more comfortable experience during extended periods of wear. By incorporating this design element, the knee pad is able to provide both functional benefits for improved performance and added comfort for prolonged use.



Bendable exoskeleton











Photo by Matthieu Pétiard, source Unsplash

CHAPTER 5

OUTRO

Reflection

Working on this project has been a fascinating experience. I was taken aback by the significant gap in the market and the limited amount of data available on injuries sustained during winter sports. Working with this subject presented unexpected challenges that were far more complex than I initially anticipated, particularly when dealing with difficult twists and turns. However, I feel immensely grateful for the opportunity to engage with the individuals I had the chance to speak with, since they provided valuable insights that aided in my continued work on the project. I find this subject matter deeply engrossing and would relish the chance to delve deeper into it. As such, I don't view this design process as complete, but rather as an introduction to what it could ultimately become.

SPECIAL THANKS TO

My supervisors Hilde Angelfoss and Ståle Møller from Sweet Protection for help, guidance and motivation

And thanks to all friends and classmates for helping and supporting me through these 5 years at AHO.

References

- skadefri., 2023. De vanligste skadene. <https://www.skadefri.no/idretter/alpint/oversikt-alpinskiader> (Accessed: 8/2/23) [1]
- Per Holck, 16 Jan 2023. Kneet. <https://sml.sn.no/kneet>. (Accessed: 8/2/23) [2]
- Osmifw, 2023. the orthopedic sports institute. Five Common Knee Injury Symptoms. <https://www.osmifw.com/orthopedic-diseases-disorders/knee-injuries-disorders/five-common-knee-injury-symptoms/> (Accessed: 8/2/23) [3]
- Naob, 2023. Det norske adakdemiske ordbok, innerski. <https://naob.no/ordbok/innerski> (Accessed: 18/1/23) [4]
- Naob, 2023. Det norske adakdemiske ordbok, ytterski. <https://naob.no/ordbok/ytterski> (Accessed: 18/1/23) [5]
- S. PEREIRA, S. C. ANAND* AND S. RAJENDRAN, 4—April 2007. A Study of the Structure and Properties of Novel Fabrics for Knee Braces. <https://journals.sagepub.com/doi/pdf/10.1177/1528083707072357> (Accessed: 23/1/23) [6]
- NHI, 02.06.2020. Idrettsskader – Alpint. <https://nhi.no/trening/aktivitet-og-helse/idrettsskader/alpint-skader/> (Accessed: 8/2/23) [7]
- Skileb, 2023. The Carving Skis. <https://www.skileb.com/tips/carving-skis/> (Accessed: 7/2/23) [8]
- Yorkshirekneeclinic, 4 JAN 2018. Should I Wear A Knee Brace When Skiing?. <https://yorkshirekneeclinic.com/should-i-wear-a-knee-brace-when-skiing/>. (Accessed 17/1/23) [9]
- Heidi Mills BSc (Hons), 2003-2023. Skiing and Knee Injuries: To Brace up or Not to Brace up?. http://snow.guide/skiing-knee-injuiry-braces/?fbclid=IwAR1oczLkKRL3A9tMs-sE52ApmEZDa896KDCIMBr6mchdezbmb_Qjyo94diyo (Accessed: 24/1/23) [10]
- Familydoctor, 19 august, 2020. Knee Bracing: What Works?. <https://familydoctor.org/knee-bracing-what-works/> (Accessed: 16/1/23) [11]

NIH, 18 July, 2008. Effects of modern ski equipment on the overall injury rate and the pattern of injury location in Alpine skiing. <https://pubmed.ncbi.nlm.nih.gov/18614888/> . (Accessed 9/2/23) [12]

Stylealtitude, October 2022. WHY ARE THERE SO MANY ACL KNEE INJURIES SKIING?. <https://www.stylealtitude.com/acl-tear-rupture-skiing.html> (Accessed 9/2/23) [13]

Kevin G. Shea, MD, Noah Archibald-Seiffer, BA, Elizabeth Murdock, MS, Nathan L. Grimm, BS, John C. Jacobs Jr, BS, Stuart Willick, MD, and Heather Van Houten, January 2014. Knee Injuries in Downhill Skiers: A 6-Year Survey Study. https://www.researchgate.net/publication/285605028_Knee_Injuries_in_Downhill_Skiers_A_6-Year_Survey_Study (Accessed 9/2/23) [14]

Pennmedicine, 2023. Medial Collateral Ligament Injury (MCL). <https://www.pennmedicine.org/for-patients-and-visitors/patient-information/conditions-treated-a-to-z/medial-collateral-ligament-mcl-injury-of-the-knee> (Accessed: 9/2/23) [15]

SNL, 12 Feb, 2021. korsbåndskade. <https://sml.snl.no/korsb%C3%A5ndskade> (Accessed 9/2/23) [16]

SNL, 28 des, 2022. menisk.. <https://sml.snl.no/menisk> (Accessed 9/2/23) [17]

Tone bere, 2013. page (30-31) Mecaninms of injuries in world cup alpine skiing. <https://nih.brage.unit.no/nih-xmlui/bitstream/handle/11250/171357/Bere2013.pdf?sequence=1&is-Allowed=y>. (Accessed 9/2/23) [18]

Maria R. Ward Rashidi, Geoffrey Frank, Ryan Seifert and Wesley Chapkin. January 2019. Biomimicry of the Armadillo Carapace for the Design of Bending Cylinders for Aerospace Applications. https://www.researchgate.net/publication/330208191_Biomimicry_of_the_Armadillo_Carapace_for_the_Design_of_Bending_Cylinders_for_Aerospace_Applications (Accessed 27.03.2023) [19]

