

**T H E P O R T R A I T  
O F A V I L L A G E**

**V I L L O P I A**

V I L L O P I A

*Text 2 - 9*

T H E P O R T R A I T  
O F A V I L L A G E

*Representations of Villopedia 10 - 87*

L I V I N G W I T H F L O R A

*Villopedia Experiment 88 - 115*

M A K I N G A N D  
R E I T E R A T I N G

*Working Process 116 - 131*

E X P R E S S I O N S  
A N D I N S P I R A T I O N S

*Collections 132- 157*



# V I L L O P I A

## 1. Intentions

*"The UN warned us that in the future, there is a possibility that only 20% of mankind will live in the countryside. I think that would be such an incredibly or dangerous but kind of simplistic and absurd neglect of all kinds of potentials."*  
Rem Koolhaas, *Countryside, The Future*<sup>1</sup>

As architects, before we start to design, we should be cautious and critical about how we can be open-minded, creative and practical. This becomes even more crucial in the context of the underappreciated villages. Actually, they are complicated and vary from each other, so I mainly focus on one type of village in southern China. The Guizhou Province has increased the urbanization rate from 14.76% according to the Fifth National Population Census in 2000 to 54.81% by the Seventh in 2020. At the same time, people advocate urban living for access to health services and education. Villages are disappearing. Artist Ou Ning's rural utopia, the Bishan Project in Anhui Province, as well as other land art festivals in villages, are not acclimatized to local farmers in Chinese rural areas. Guizhou's Village Soccer Super League indicates the success of self-motivated physical activity.

Locals' understanding of the territory is based on everyday life, while outsiders' is based on transplanting imaginative re-creation. When it comes to architecture in the long-term perspective, the spontaneous living program linked to being intimate with the land is more important. Copies of the facade of the traditional houses and the implantation of the function of café and art won't work. Architecture in villages needs to help people re-connect with the land.

At the beginning of this project, I was curious about why some people were so attached to the specific villages and thought it would be worth registering for a normal village from a decentralized perspective.

<sup>1</sup> Questioning the Future: Rem Koolhaas at the Guggenheim, <https://www.guggenheim.org/video/questioning-the-future-rem-koolhaas-at-the-guggenheim>

## 2. Villopedia

*"Utopian envisioning is necessarily provisional, reflective and dialogic...The utopian alternative is to think where we might want to get to and what routes are open to us."*  
Levitas, *Utopia as a method*, 2013<sup>2</sup>

In terms of architectural space, the village is a place where people pass on the same traditions generation by generation and settle the landscape spontaneously. General traditions are living records in the landscape which could be the techniques for farming, customs in holidays, construction of vernacular buildings and structure of people's relationships. The Guizhou Province is located in the terrain of the Yunnan-Guizhou Plateau shaped in mountains. The inaccessibility, uncertainty of weather, and enclosure of the mountains add mystery to the villages among the mountains. As depicted in two sets of long takes from Bi Gan's film, *Kaili Blues* (2015), the protagonist is traveling on a winding mountain road among the foggy, green and endless mountains to an unknown place. The village I study is my dad's hometown Tangjiangxi, which is the same as the name of the river flowing through. All Chinese characters in this name have "氵" which means quality of water. Mountains and water are crucial elements to live in the village.

Villopedia is made up of village and utopia as a concept to reconstruct utopian life in the village and to make it accessible for us. Due to the lack of recordings of the village, memory is a main tool for "looking at" connections through an everyday journey. At first, I wanted to portray the feeling of being in the village. When the different locations are linked together, a daily register of activities is created, which is recorded in the architectural and landscape space. A chair invites people to access the place and lives of the village, to perceive and reflect their own experiences. Then a table brings us to know the meaning of villopedia in the urban area.

<sup>2</sup> Nathaniel Coleman, *Lefebvre for Architects*, London: Routledge, 2015

### 3. Memory Journeys

*“Even the highest mountains  
are no nearer the sky than the deepest valleys.  
There is no more sky in one place  
than another.”*

*The Sky, Wislawa Szymborska*

The memory of going back to the village starts from traveling in the car. I questioned why we had to go to the village, suffered from carsickness and marked the road where car accidents happened frequently, where there had been a murder and where we would go through the “green tunnel”. After the car, we need to walk to the village through the mountains and along the river.

After we arrived, everyone settled and made a fire. (D1) I named the room black space because of the small wooden lattice window which is darkened by the separation with the light of the landscape but also lighted by firing the materials of it. The passage between houses was occupied by firewood and coffins which were built because the wood was good at that year. Only a line of light can get into creating a sense of earth related to death. (A3) Through the passage, we reach the mountain behind the house to scoop water from the well. (A4) It is greeting time when neighbors pass by the house to get water. Following the path up the mountain, ancestors’ graves and pomelo tree appear. (A5) Vegetables, such as potatoes, cabbage and green onion are grown in higher places. (A6) To chop firewood, graze cows and pick up tung oil seeds, we need to go farther into the mountain. (A7) When it comes to rituals, every dish should serve to ancestors’ space, which is a small space embedded in the stone wall in front of the house with a walnut tree. (A2) Paddy rice and canola are grown in the field of the valley, where the water is easily obtained from the river and mountain. (A1) When we look back at the mountain, all the traces and layers are merged. (A)

Fog being mixed with smoke, crisp cockcrowing, the voice of burning firewood and boiling food reflect the silence of the morning. (E, D2) The journey for going back follows the path along the river which connects to other villages. We go

across the river on stone steps and take a shortcut through small woods, where a tiny temple is dedicated to the god of earth. (B1) Facing fields of canola flowers, we sweep graves and worship ancestors in spring. (B2) The river rises when it is raining season. After that, it is summer time to step in the water to grab creatures. (B3) When the fields turn yellow, the mouth will be satisfied with wild fruits’ different tastes. (B4) The path is separated from the river to the town. When we are far from the river, we get further away from the village. However, the journey of villagers repeat in everyday life, accumulating vertical layers of them. (C) When black space is lighted, we are here in the village again. (D1)

### 4. Traces of Lives

*“The case for the Historical Center of Bahia is not  
the preservation of important architectures, but the  
preservation of the City’s Popular Soul.”*

*Lina Bo Bardi, 1986<sup>3</sup>*

#### A. Black Space

Darkness is the most remarkable feature of the vernacular wooden house. The first layer of darkness is painted with black oil from the local tung oil tree on the exterior facade for preservation. The tiny wooden lattice windows are plastered with current newspapers to protect the surface of the interior wood wall, making the interior dimmer. At the same time, the newspapers on the wall are media to access the outside world. The most commonly used space is the kitchen which is blackened by the smoke of the fire. Adults sit around the fire, cooking, adding firewood, talking and being silent. Writer Junichiro Tanizaki praised shadow for its mystery being superior to any ornament.<sup>4</sup> All the blackness creates the intimate and infinite darkness of the limited room.

As an immediate and strong contradiction, people encounter the upper sky, sounds and smells of all creatures, humidity, and temperature when they leave the room, the second they enter the landscape. The darkness of night in the landscape is not the same as in black space. It is a process:

<sup>3</sup> Lina Bo Bardi, Tokyo: TOTO, 2017

<sup>4</sup> Junichiro Tanizaki, In the praise of Shadow, New York: Vintage Books, 2001

you sense infinite darkness in the beginning, and dark blues and dark greens gradually appear like in Monet's paintings in the Orange Gallery. More intensely, it's a continuous space enveloping you, the houses, the sound of animals and the shadow of plants, the whole mountain, and the whole canvas is the sky.

### **B. No Interaction or Boundary**

There is no direct interactions between architecture and landscape. The house is introverted without any framed view of landscape. However, there are no boundaries between architecture and landscape either. Outdoor senses dominate the village life instead of indoor visual vision. This sensory experience is enhanced by daily indoor and outdoor mobility. It is closer to the outdoors in the black space than a glass house. Gestures of space allow for the continuation of the interior and exterior, such as stone steps, from darkness to light.

Human, crops and animals have shared the black space. Movement of human in the village is the process to exchange other creatures with materials from landscape by being intimacy with the land. All the processes are recorded in traces, referring to the position of materials, the direction of movements and material forms in different periods. All the traces interact in the architecture which is an epitome of landscape for different lives.

### **C. Limited Visibility**

Only in the valley can we have the whole view of the mountain and sky. The trees hide the view from people when we stand at the top. It is not just a mountain, but continuous ranges. This limited relationship between man and mountain subverts the modern view contained in Caspar David Friedrich's celebrated work *Wanderer above the Sea of Fog* (1818). Lives in the village never thought of conquering nature. It is also impossible to have an overview of the house. When we are in the woods, we can only see the path leading to the courtyard in front of the house. When we are on the mountain behind, only the roof can be seen and the house will disappear soon behind the canopies. The house is not the symbol of the home, but the path or the smoke of fire. In this sense, landscape defines the architecture.

### **D. Thoughts on land and dirt**

Land art reveals topography and materiality of the natural land what we always neglect. The artists let the existing things to be seen. Richard Long's simple and geometrical line on the map disappears when he walks into the landscape. He met with the all materials from the landscape to stop him from walking in the line. It reminds me of my classmate Marie's video about her line walking in Lista, Norway. It is impressive that she tried to walk in a line from her perspective, but from the audience's perspective, she walked in a twisted path to follow the available space in the wild landscape. It is also same as Christo's fabric work, *Running Fence* (1976), which lets the form of the valley come out. The important is how we follow what exists on earth.

We figure out the "form" of the land because the figure comes out from the ground. Jeanne mentions that dirt is literally the ground. She thinks that everything turns into dirt and that the "disorder" caused by the irreversible entropy was what interested Robert Smithson.<sup>5</sup> Everything in the village is dirt or made from dirt. People work with dirt to grow plants as figures out of ground. It turns into a reversible and ongoing process with repetition of making.

## **5. Villopia Experiment**

T.S.Eliot says being traditional is not only write the current generation but also with a feeling of the whole history which are "acutely conscious of their place in time".<sup>6</sup> The villopia project starts with the emotions of nostalgia, but it is meaningful to transfer the discoveries into our present.

When the traces of villopia come to the semi-urban house is to live with flora by reconnecting to work with the land. Adolf Loos claims that architecture stimulates moods in people, so the architect is to give this mood concrete expression.<sup>7</sup> The registering of plants reveals the mood of being in the place not just the functions of the building. In this experimental project, architecture is living through continuous interactions with the landscape. This is where the practical villopia starts.

<sup>5</sup> Jeanne Dunning, "Thoughts on Dirt: On Walter de Maria's New York Earth Room and Robert Smithson's Partially Buried Woodshed", *Artists on Walter De Maria*, New York: Dia Art Foundation, 2017

<sup>6</sup> T.S.Eliot, "Tradition and Individual Talent" (1920), *Selected Essays*, New York, new edition, Harcourt, Brace & World, 1964.

<sup>7</sup> Adolf Loos, "Architecture", *On Architecture*, Ariadne Press, 2002







# THE PORTRAIT OF A VILLAGE

Mood in the landscape

12 - 19

Memory Journey

20 - 73

Traces of Lives

74 - 87



**M O O D I N T H E L A N D S C A P E**



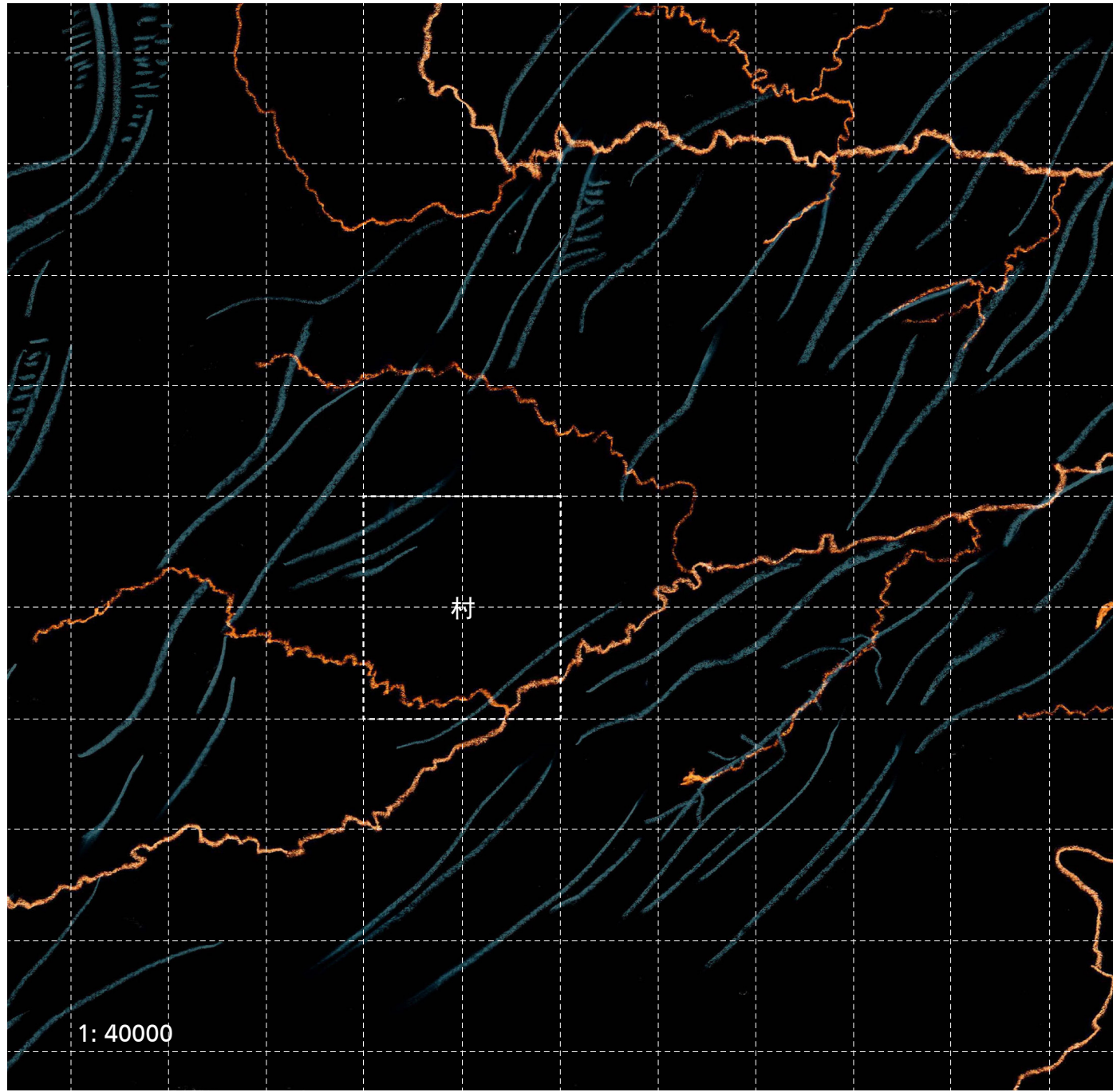



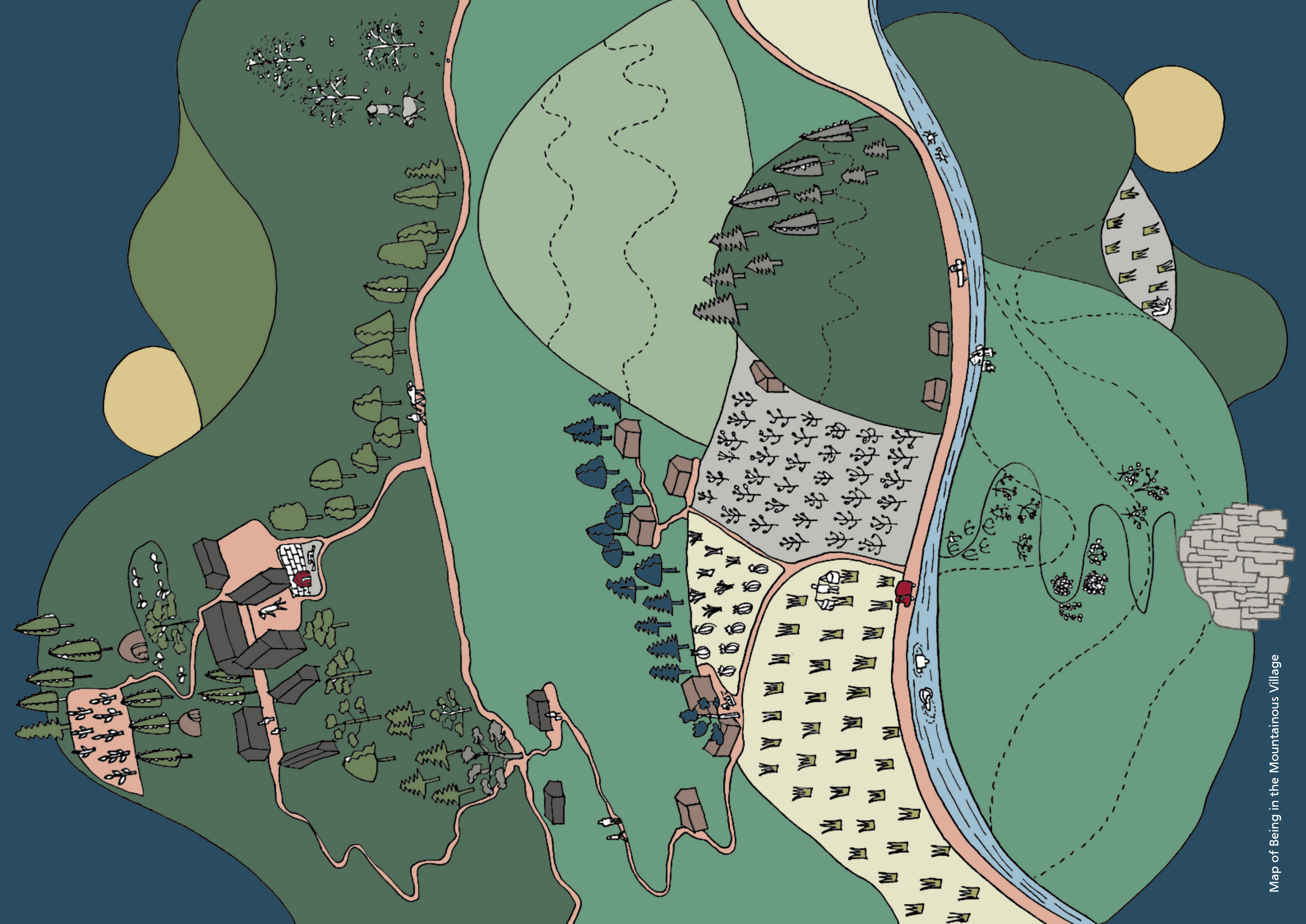

Map of Being in the Mountainous Village





**M E M O R Y J O U R N E Y S**

## Genealogy of generations' names in the village

罗 / luó (wet),  
诗 / shī (poem),  
震 / zhèn (judder),  
应 / yìng (reply),  
志 / zhì (ambition);

永 / yǒng (forever) / Ming Dynasty (1368-1644)  
远 / yuǎn (far),  
启 / qǐ (beginning),  
春 / chūn (spring),  
回 / huí (back).

斗 / dòu (fight),  
声 / shēng (sound),  
世 / shì (generation),  
泽 / zé (favor),  
忠 / zhōng (loyal);

安 / ān (steady),  
邦 / bāng (country) / The present (2023),  
定 / dìng (peace) / The present (2023),  
国 / guó (country),  
维 / wéi (maintain).

先 / xiān (former),  
德 / dé (moral),  
有 / yǒu (have),  
召 / zhào (impel),  
号 / hào (convey);

要 / yào (will),  
走 / zǒu (walk),  
胜 / shèng (win),  
汉 / hàn (ethnic group),  
涛 / tāo (weave).

一 / yī (first),  
才 / cái (talent),  
由 / yóu (reason),  
昌 / chāng (prosperity),  
秀 / xiù (elegant);

同 / tóng (same),  
振 / zhèn (vibration),  
大 / dà (big),  
舜 / shùn (mythical sage and leader),  
尧 / yáo (mythical sage and leader).



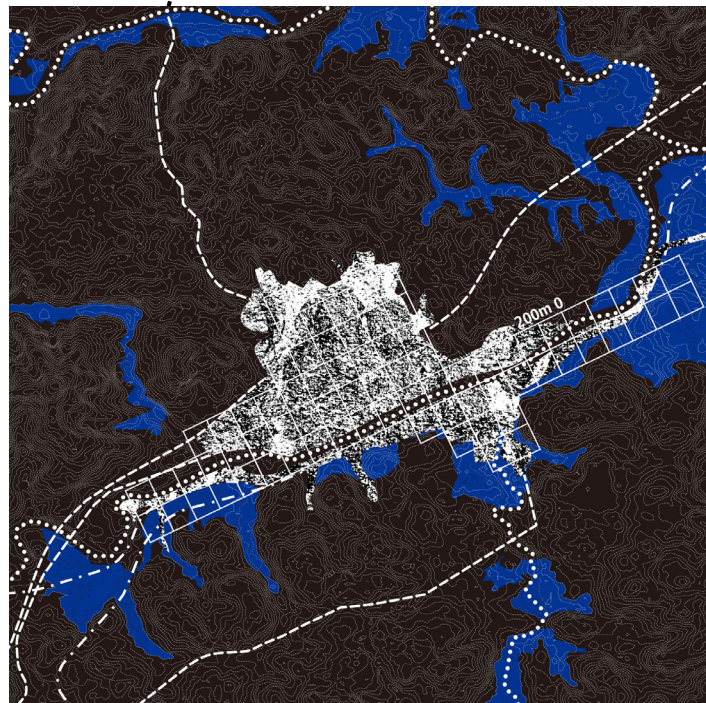

Cengong County  
1:18000

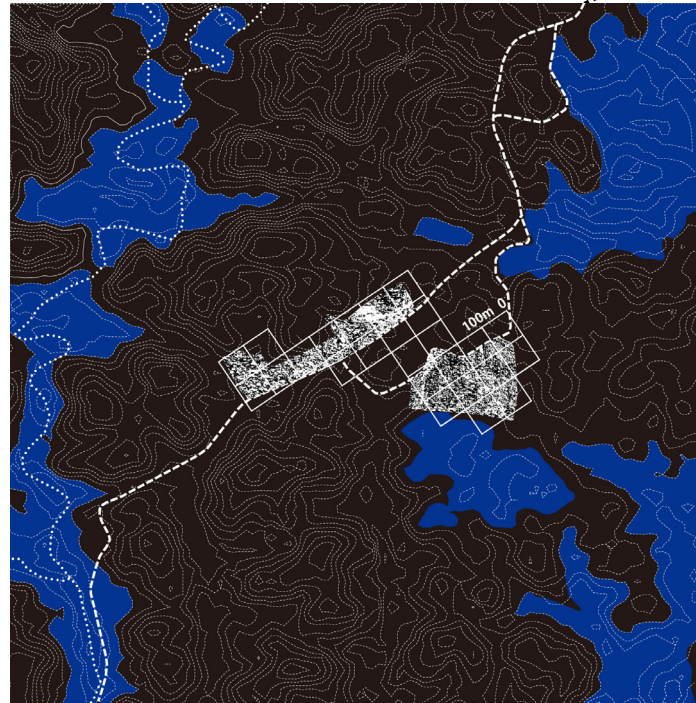

Dayou Town  
1:8000

Tangjiangxi Village  
1:4000

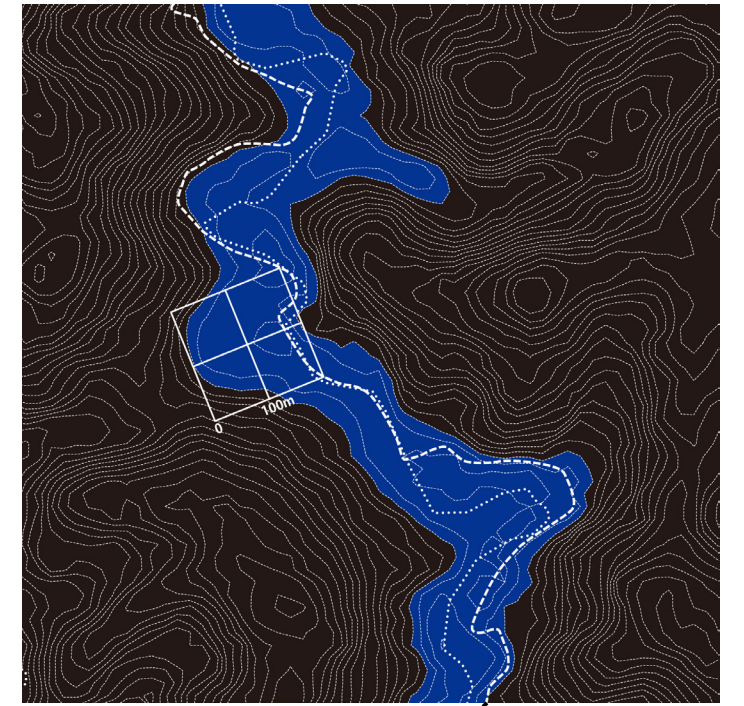

- Road
- ..... River
- Railway
- Farmland
- Urban area





*My grandma was deeply sad because of the death of the uncle. My cousin kept asking random questions when we picked vegetables to distract her attention.*

*"Grandma, what's this?"*

*Last second, she was still sobbing and mumbling. But she became confident and professional enough to answer, "This is green onion, how can you not know the basic vegetable!"*





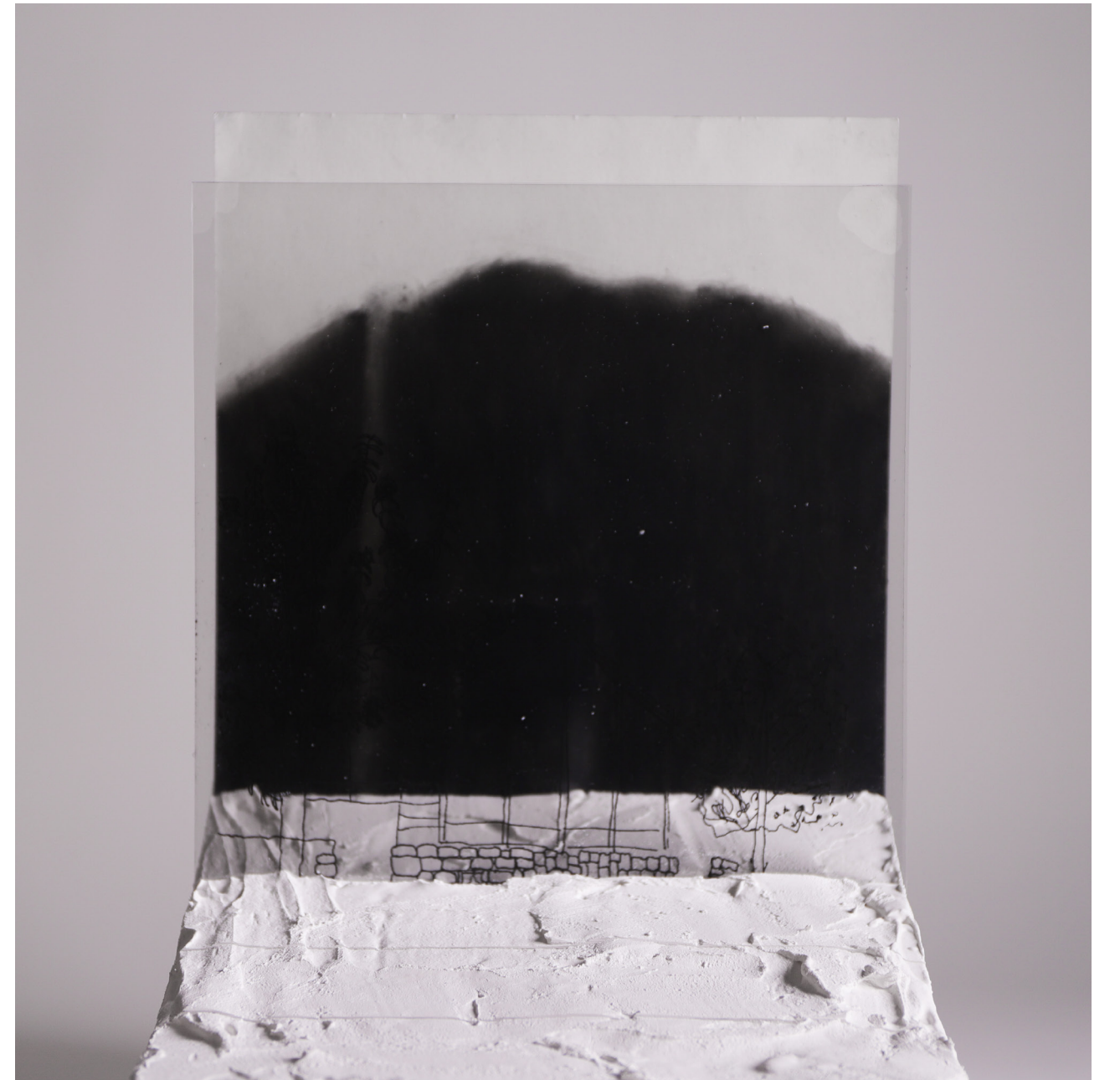

*One time, your grandpa had a meeting in the city. I was a little boy at that time. And I just learned to chop small bundles of firewood and begged my grandpa not to fire my wood. I eagerly hope your grandpa praises me when he comes back. I stood in front of the door, pretending that your grandpa was back and rehearsing our conversation:*

*"You are back!"*

*"How's your wood cutting going?"*

*Show the firewood to him.*

*"Nice cut!" He seldom did the praise.*





*As long as stay overnight, my body would be allergic. Nobody has the same situation, and nobody knows why. Conventional life experiences are no longer sufficient to explain it, so the only way is to escape.*







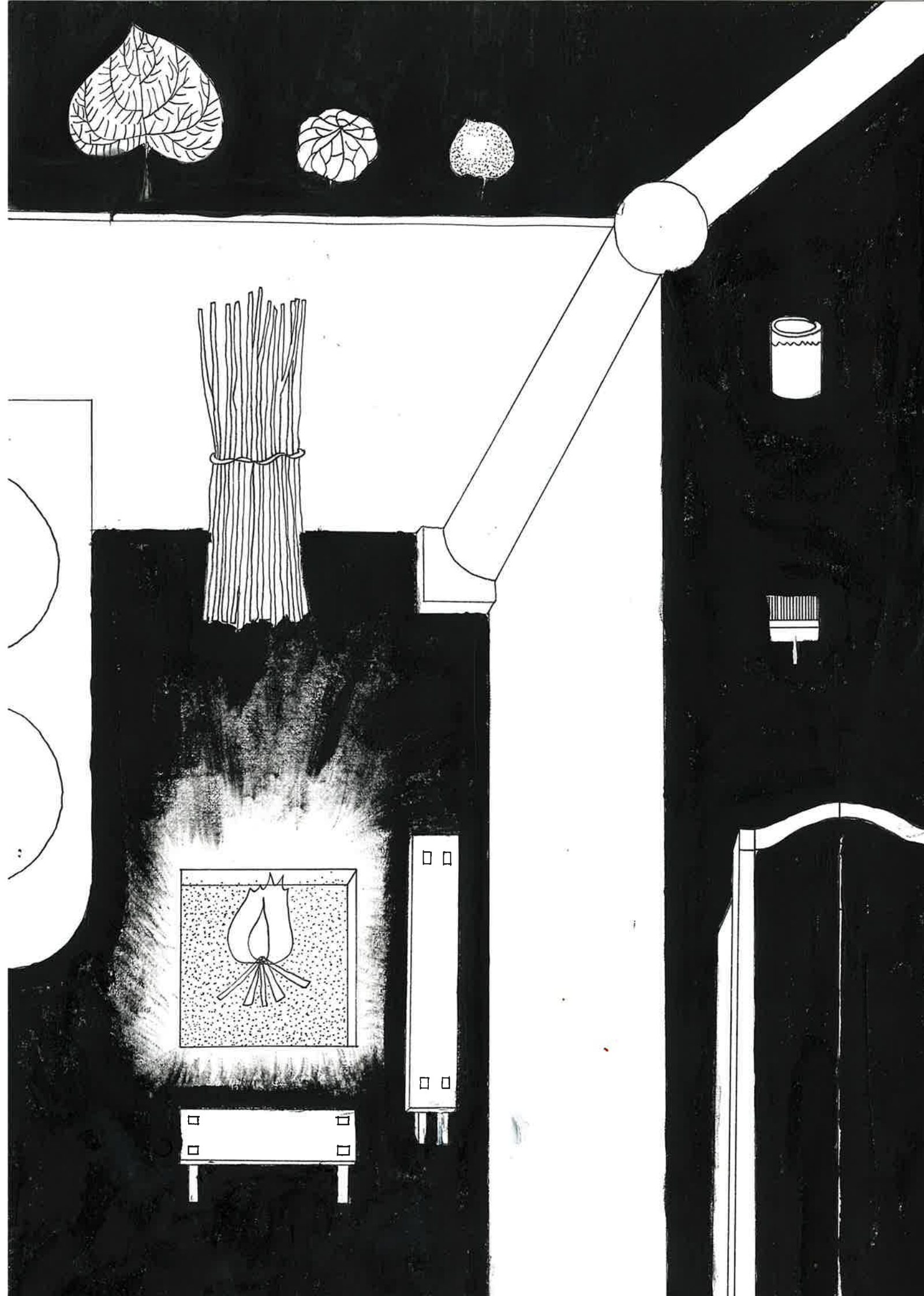





*The well is the beginning of every day's activities and the place where neighbors meet.*













How the mountain, well, firewood, people and the house meet together







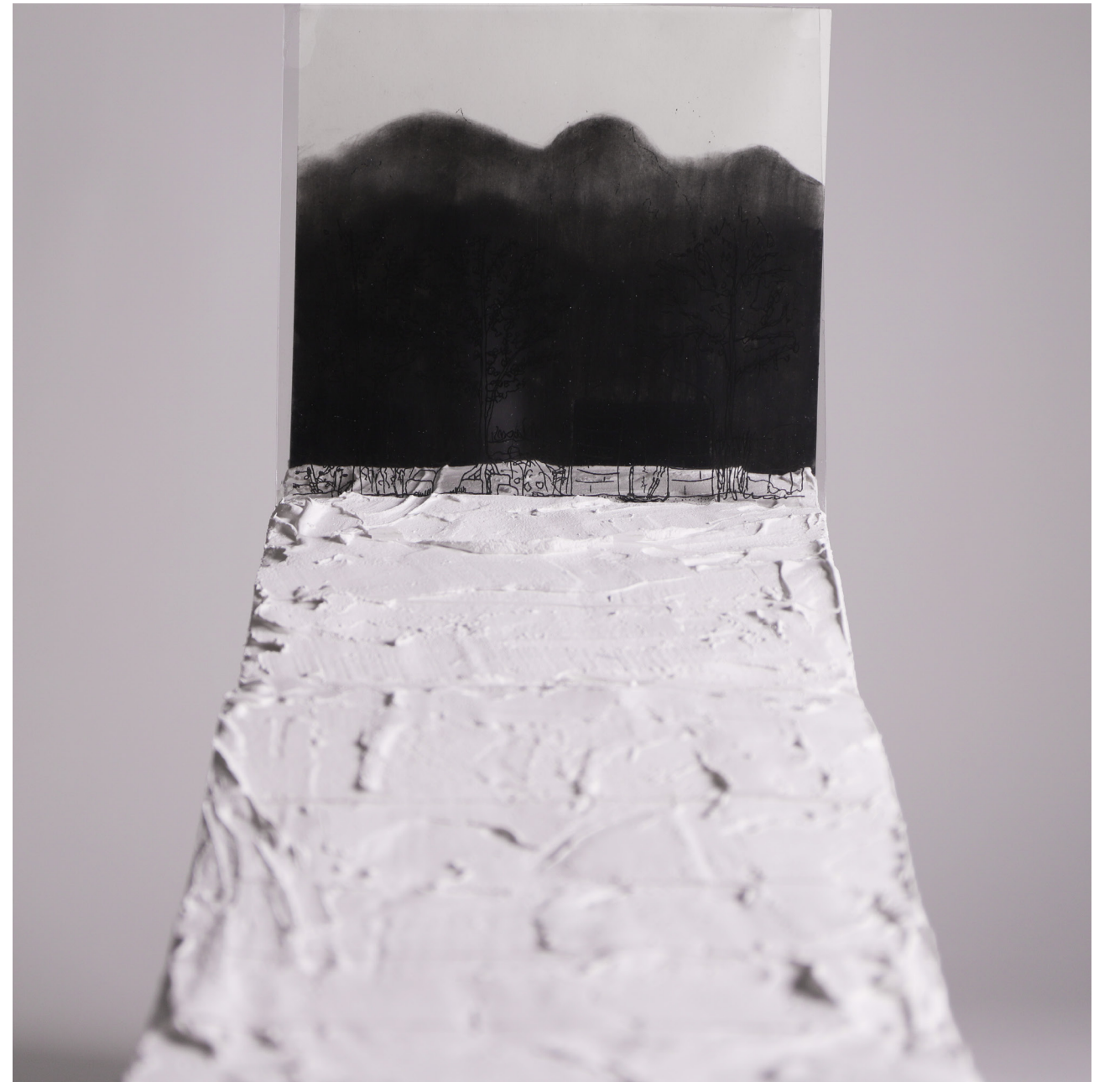

*My grandpa probably could have been cured in the hospital.  
But he didn't want to because  
he was afraid of passing away there.  
He wants to be buried here.*





*Into the winter, the morning after class, my father organized the students to go to the mountains to pick up tung oil seeds which could be sold to the production team. Then the school will use the income to buy recreational supplies for exercises, repair desks and so on.*







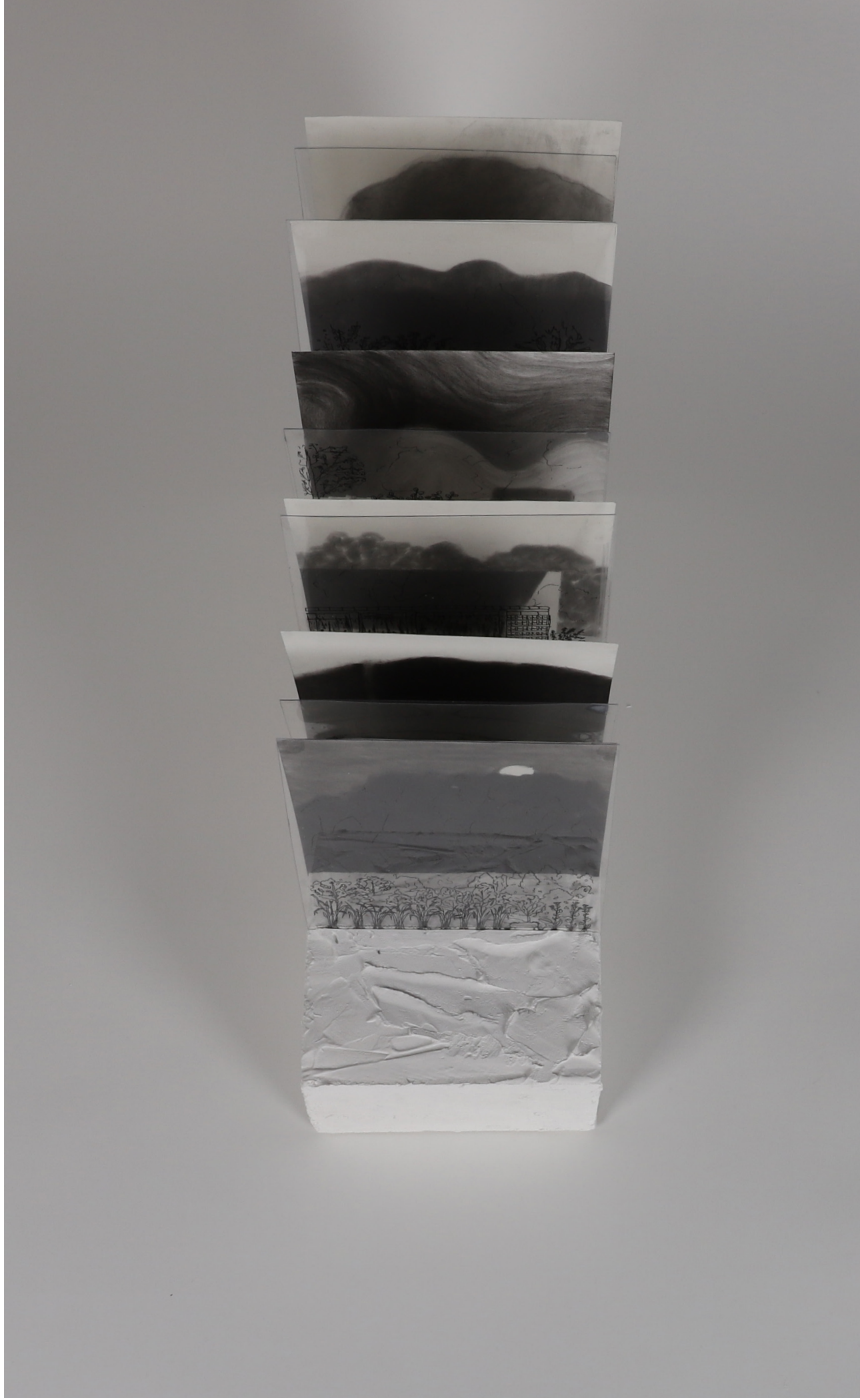

Map of Daily Journey

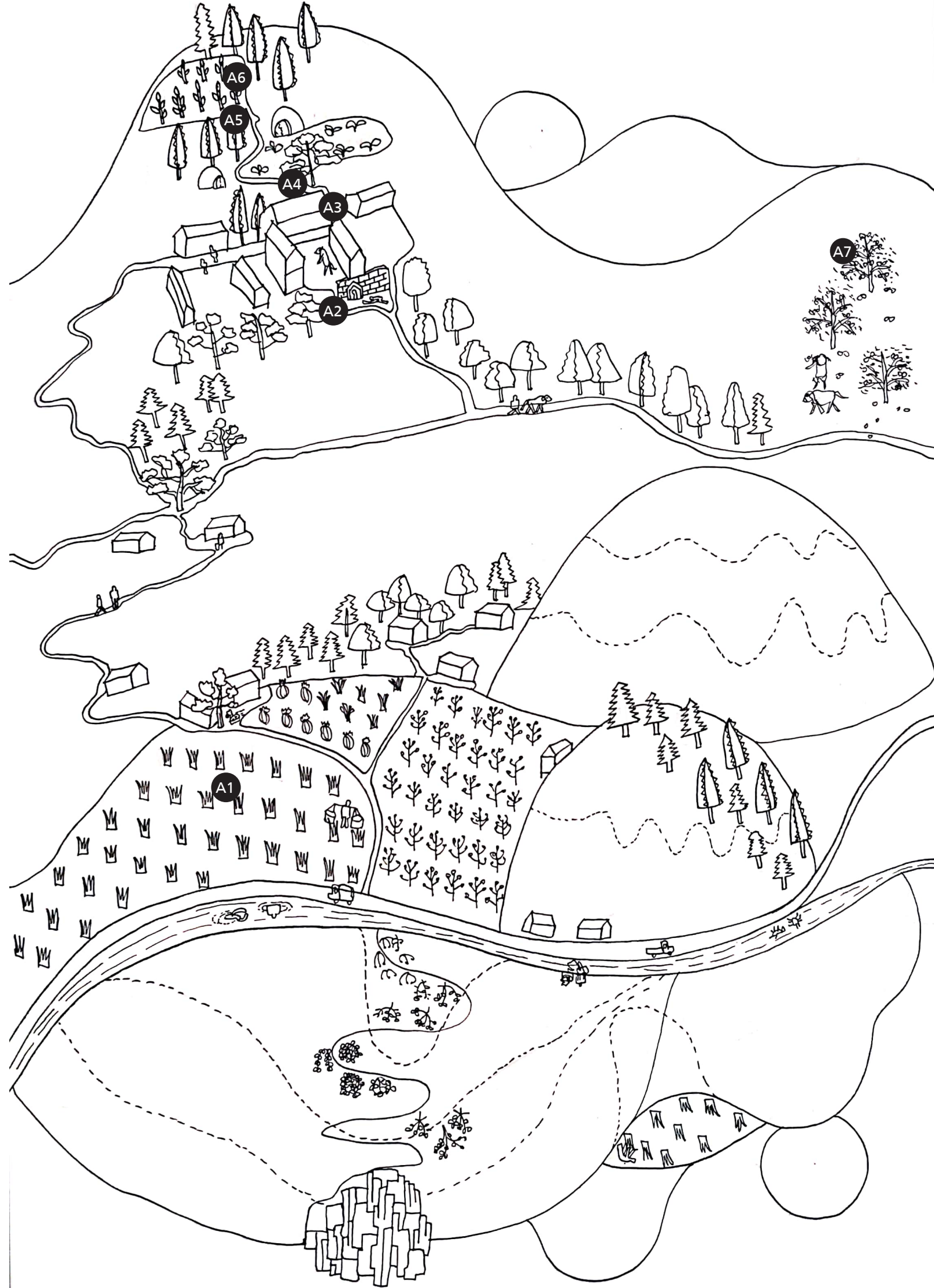









With red candles and paper,  
Into woods in a cold foggy morning,  
Leaving behind wax and dust.





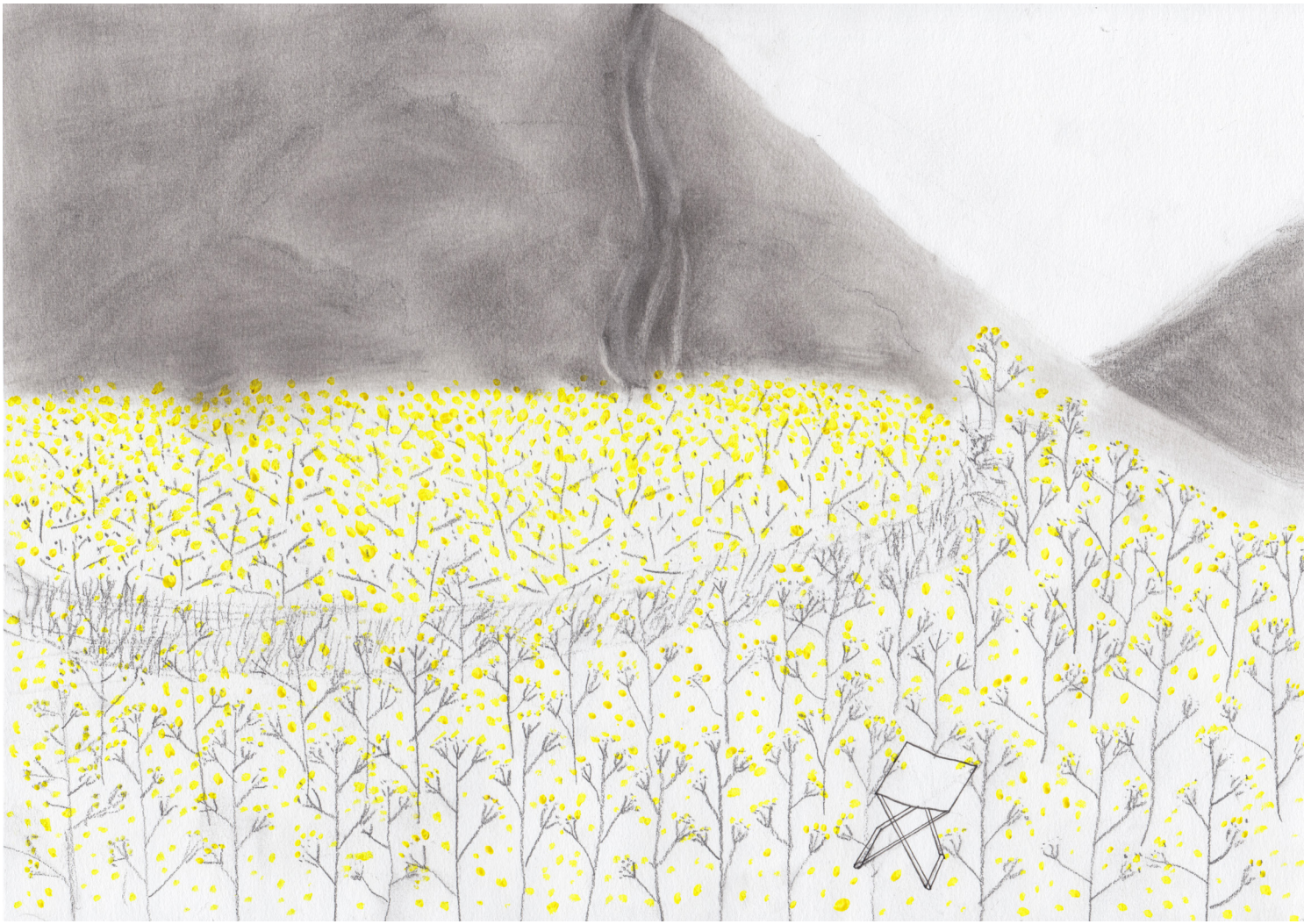

Wind flows canola field,  
Boom! A wisp of smoke above,  
Wind comes again.







The river runs over feet,  
Fish, crabs, shrimps under stone,  
Catch in the basket.







Up the twisted paths,  
Thorns down to the earth,  
Juicy, sweet, bitter and sour.













Map of Journey models

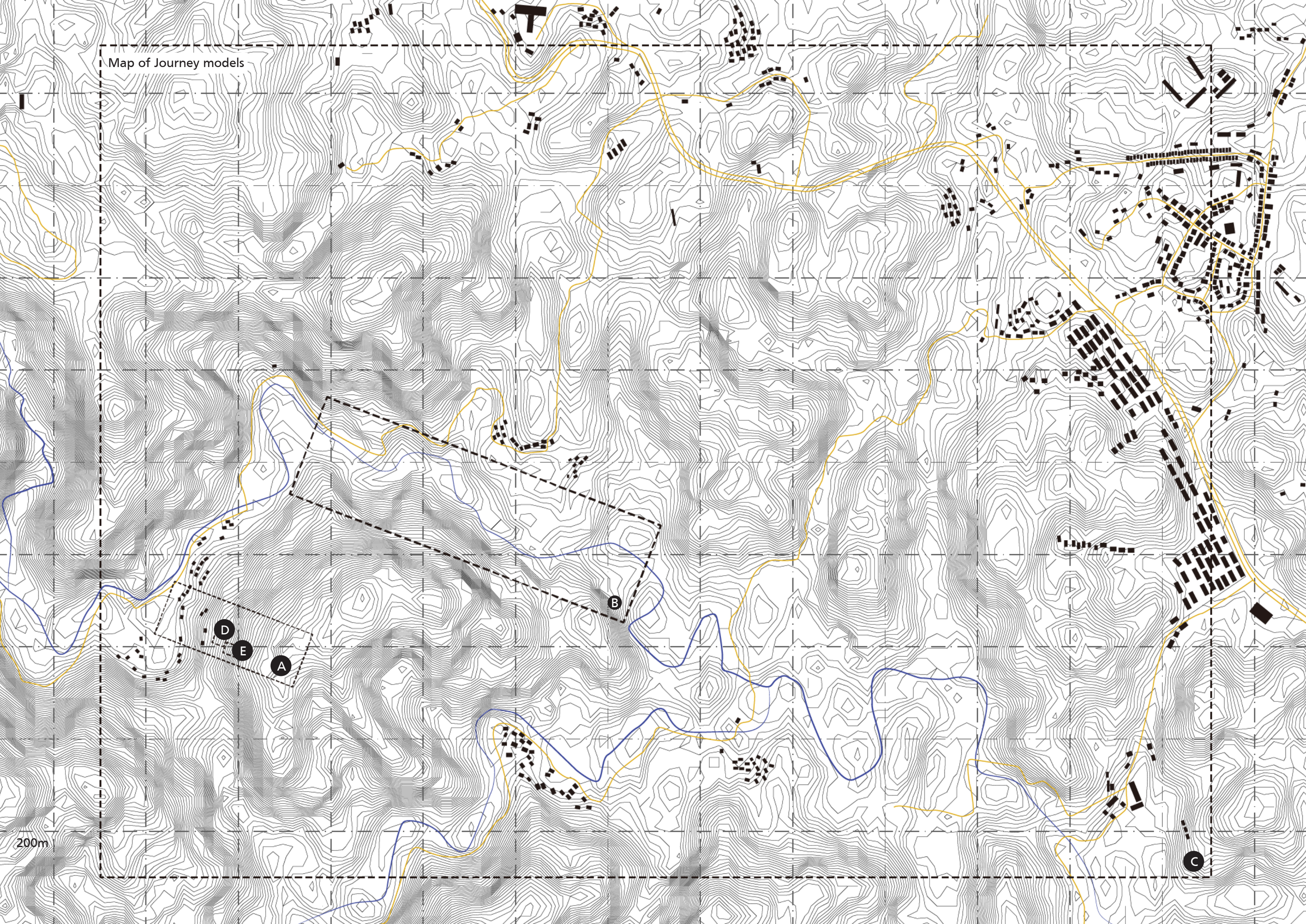









**A** Daily Journey

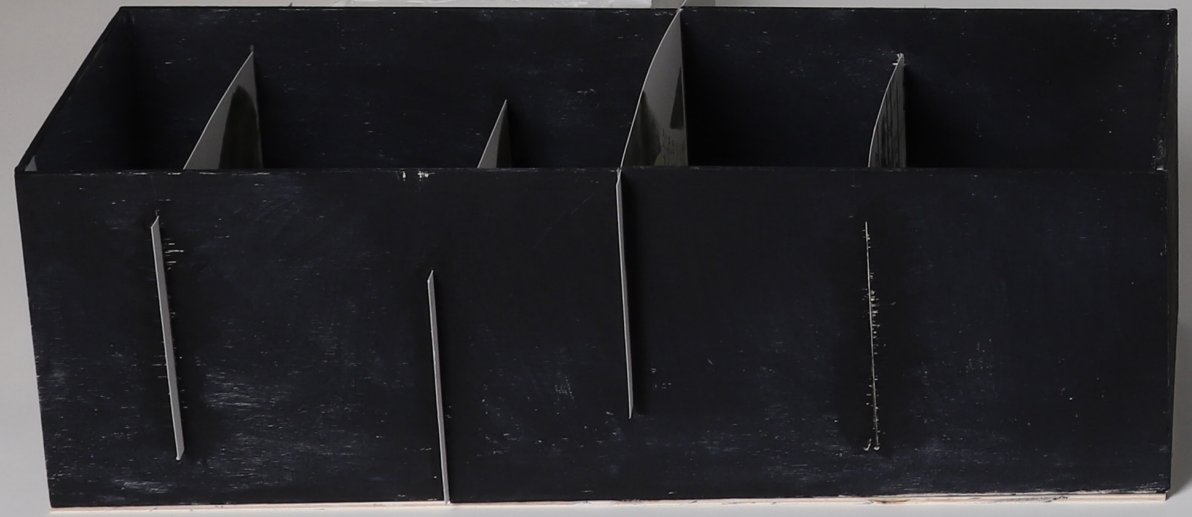

**B** Yearly Journey



**D** Black Space



**E** Black Space 2



**C** Layers of Journey



**T R A C E S O F L I V E S**



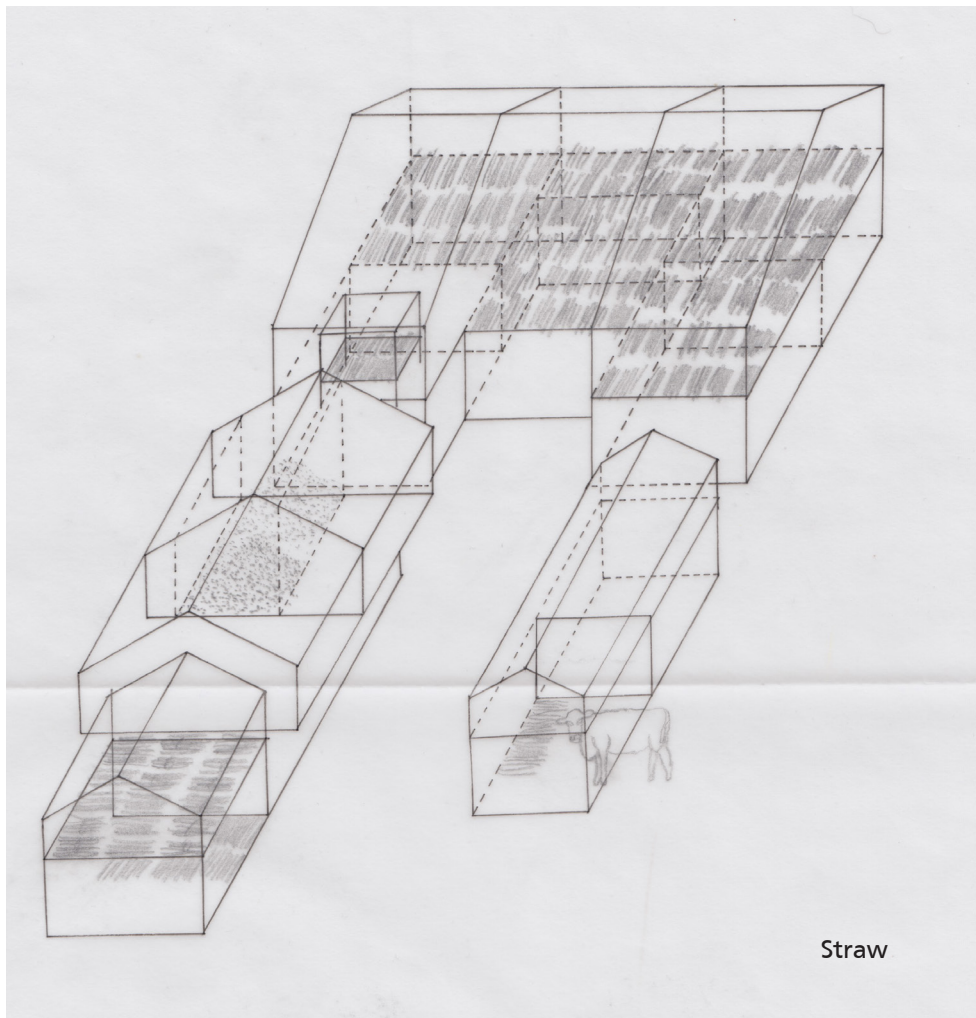

Straw

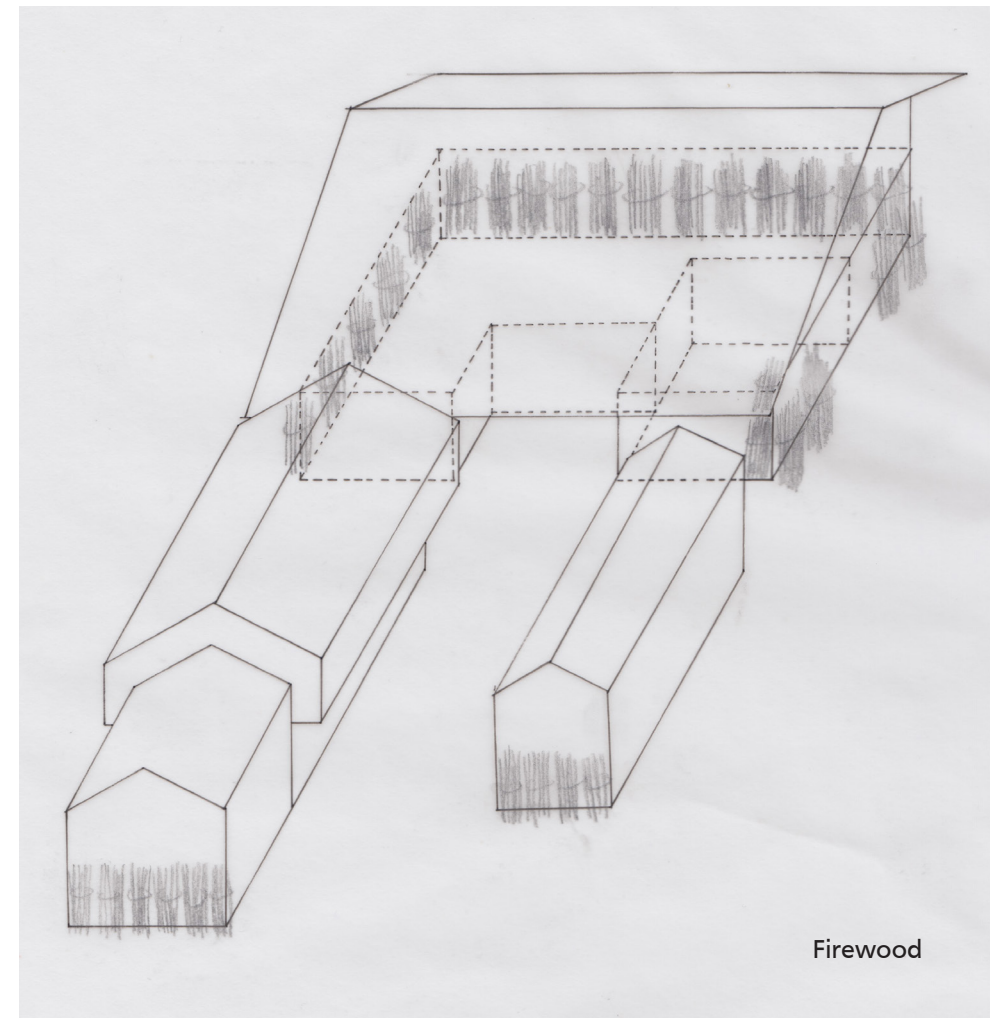

Firewood

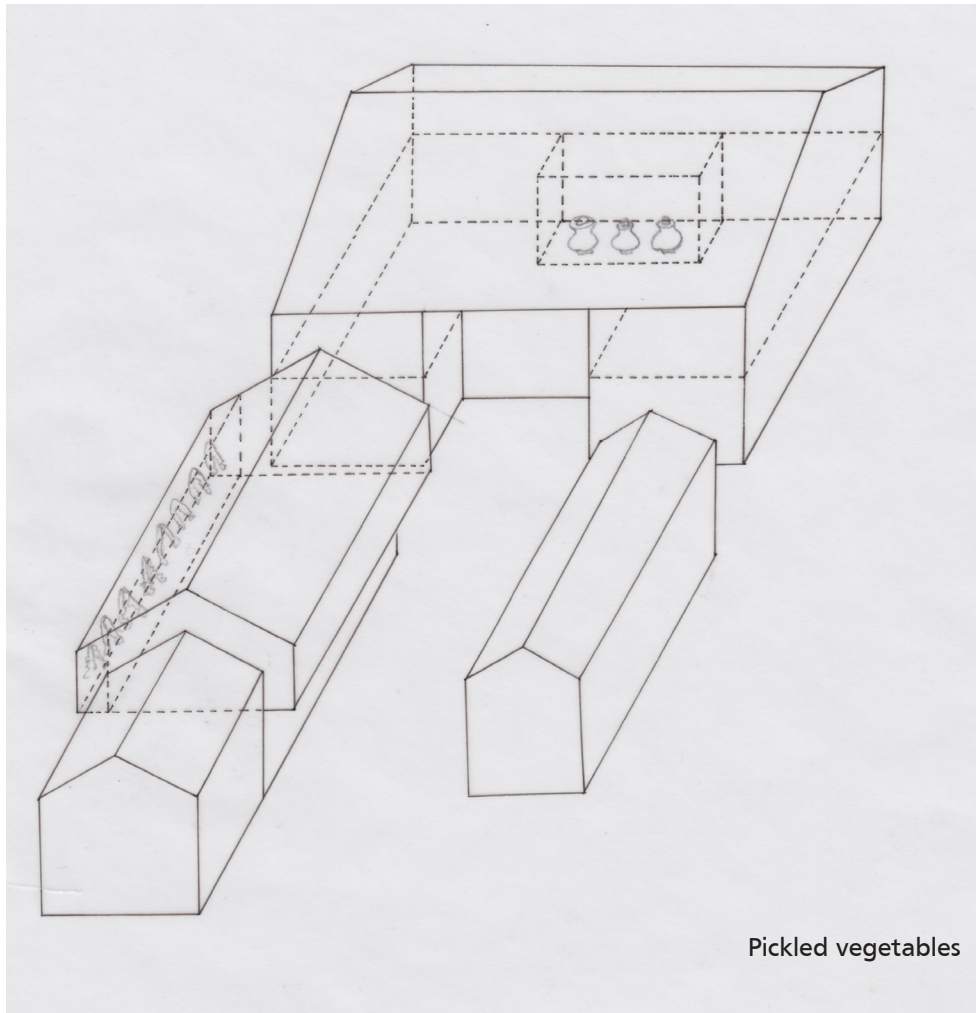

Pickled vegetables

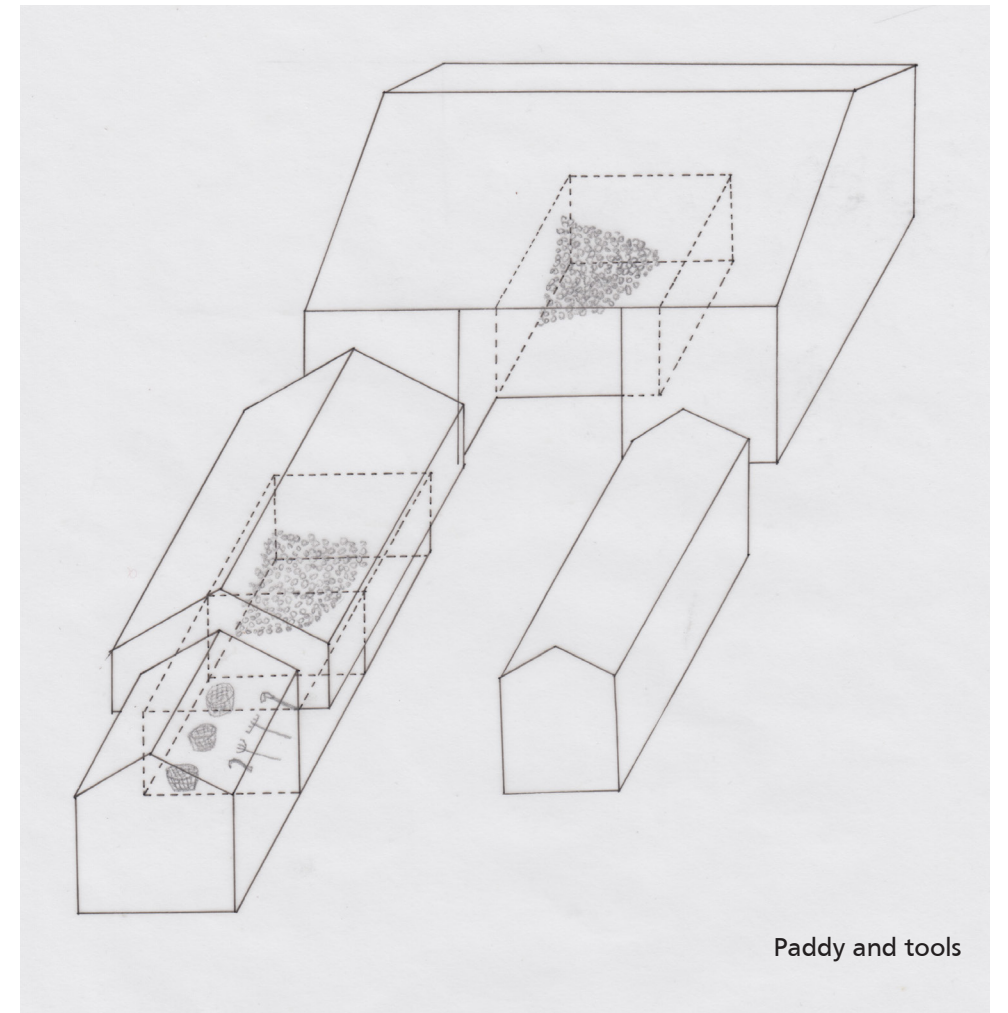

Paddy and tools



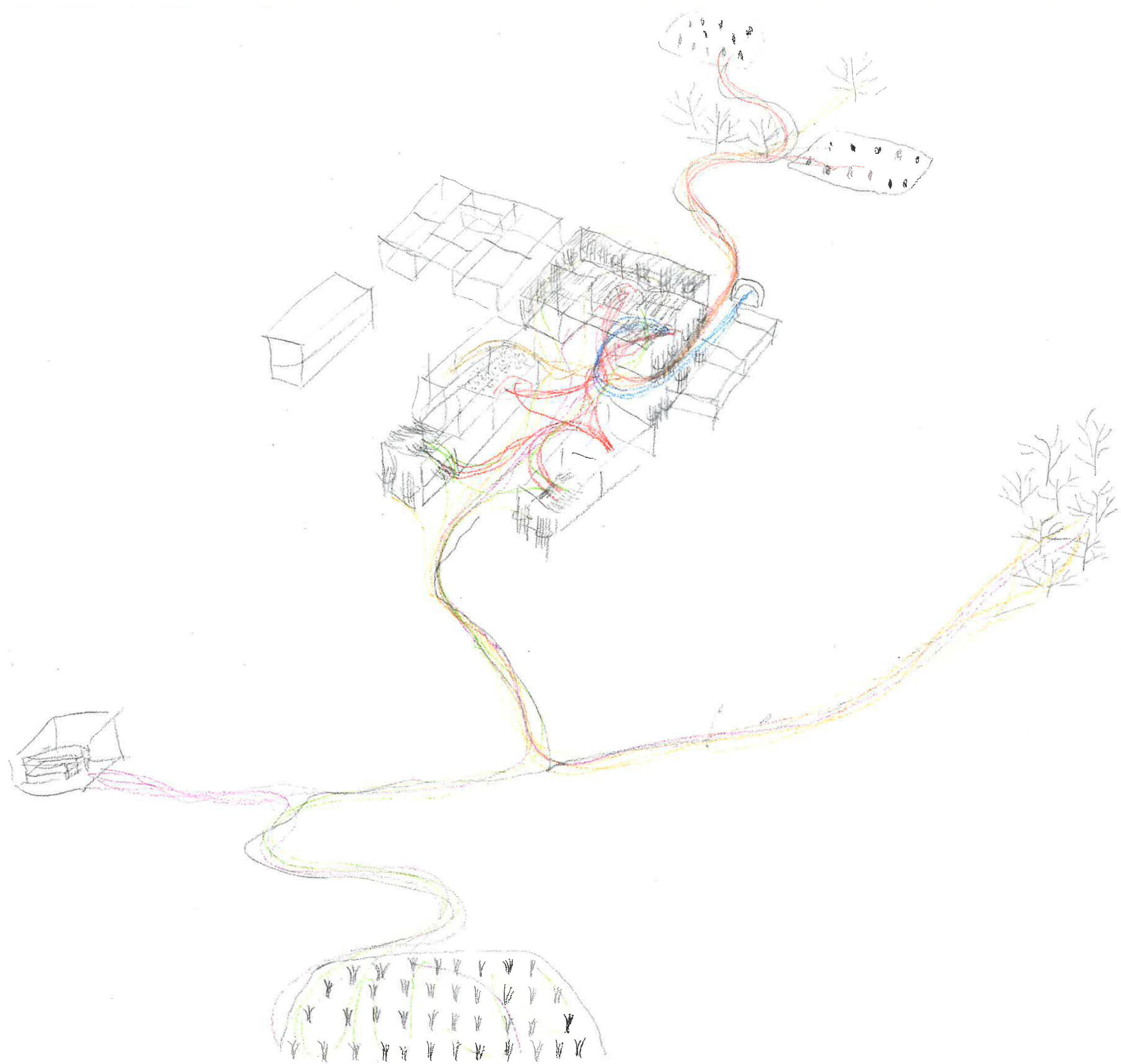

- Firewood
- Paddy rice
- Water
- Potato
- Pickled vegetables
- Tung oil plant



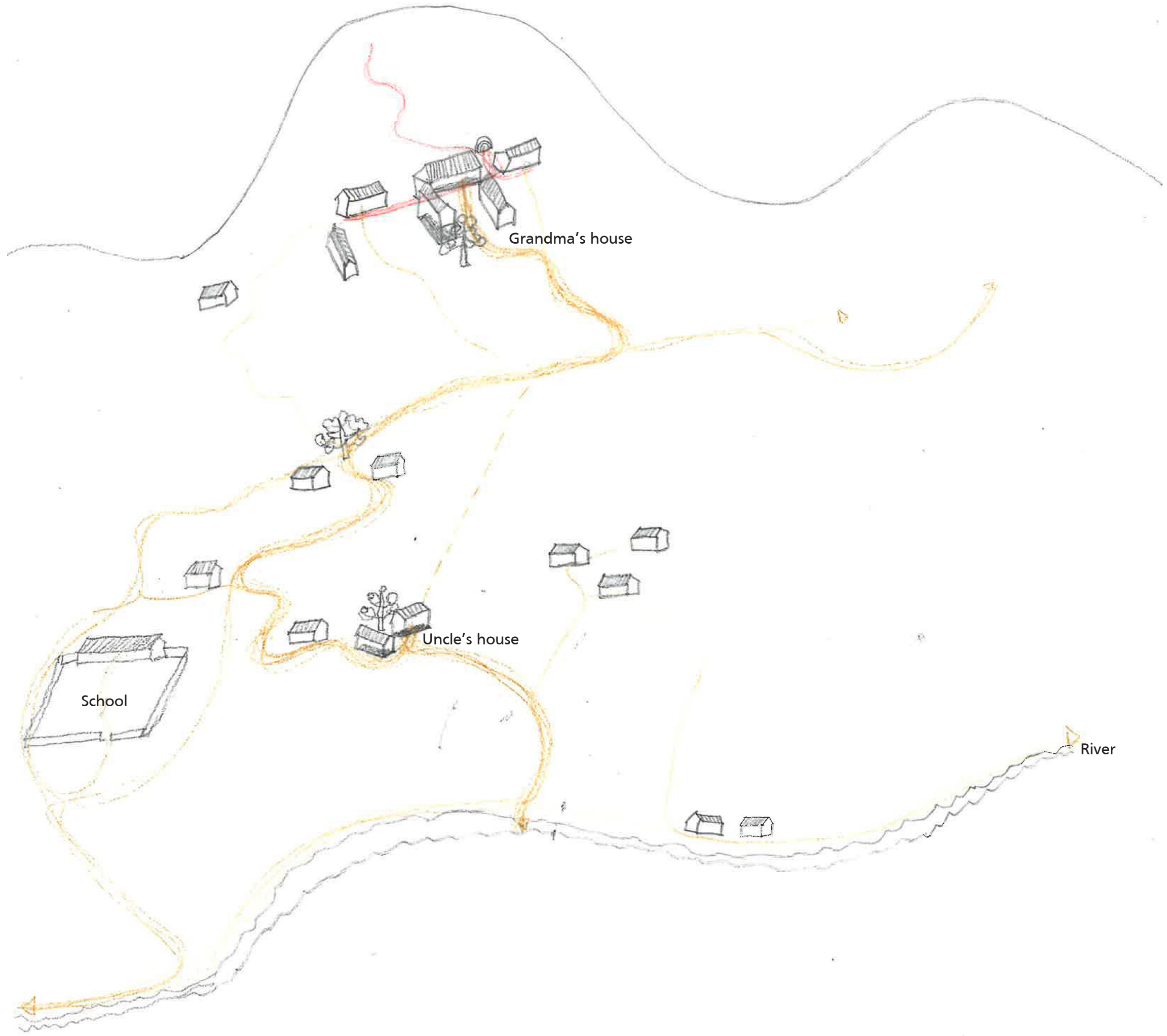

- Traces of neighbours
- Traces of villagers



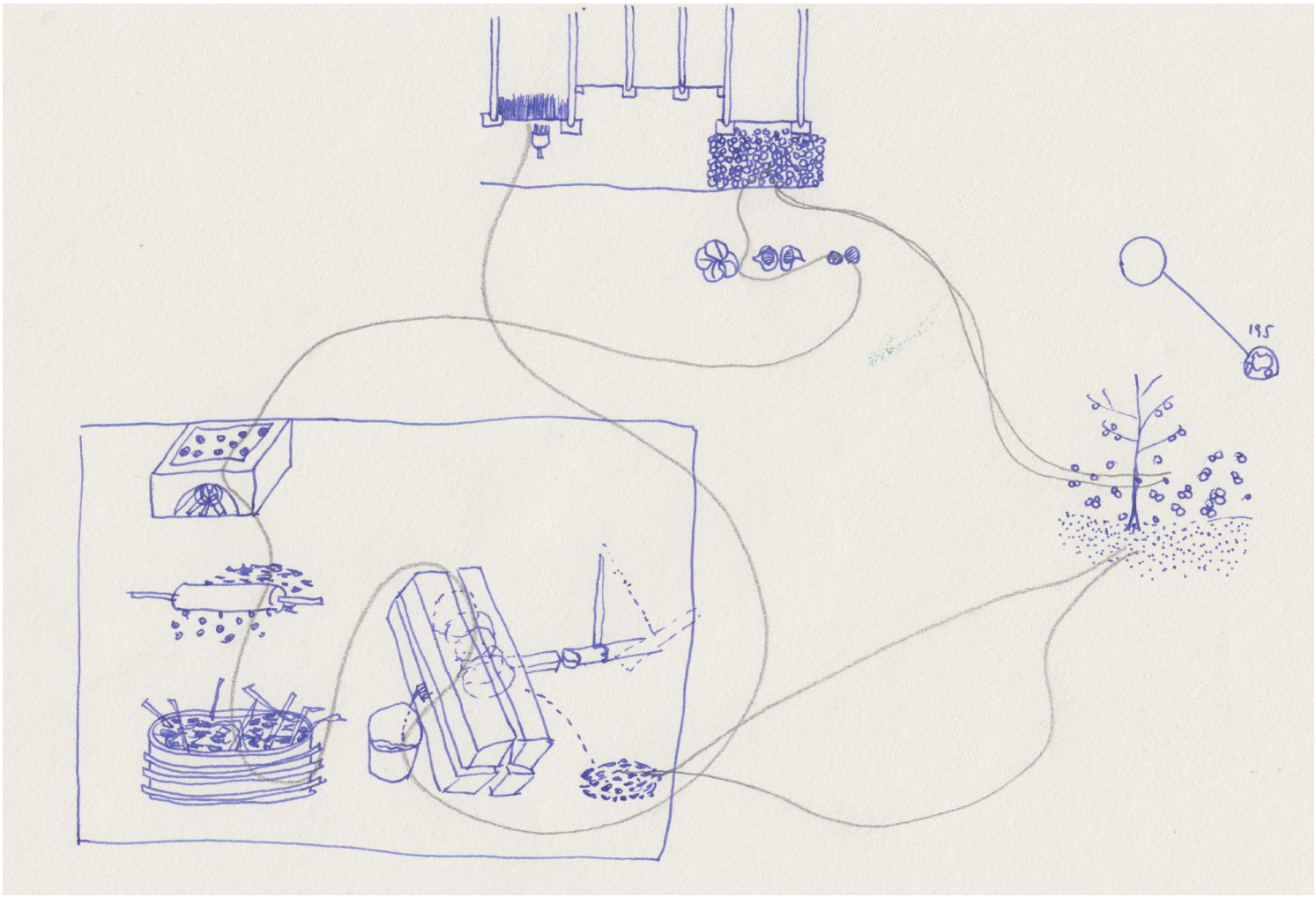

82

Life cycle of tung oil seeds

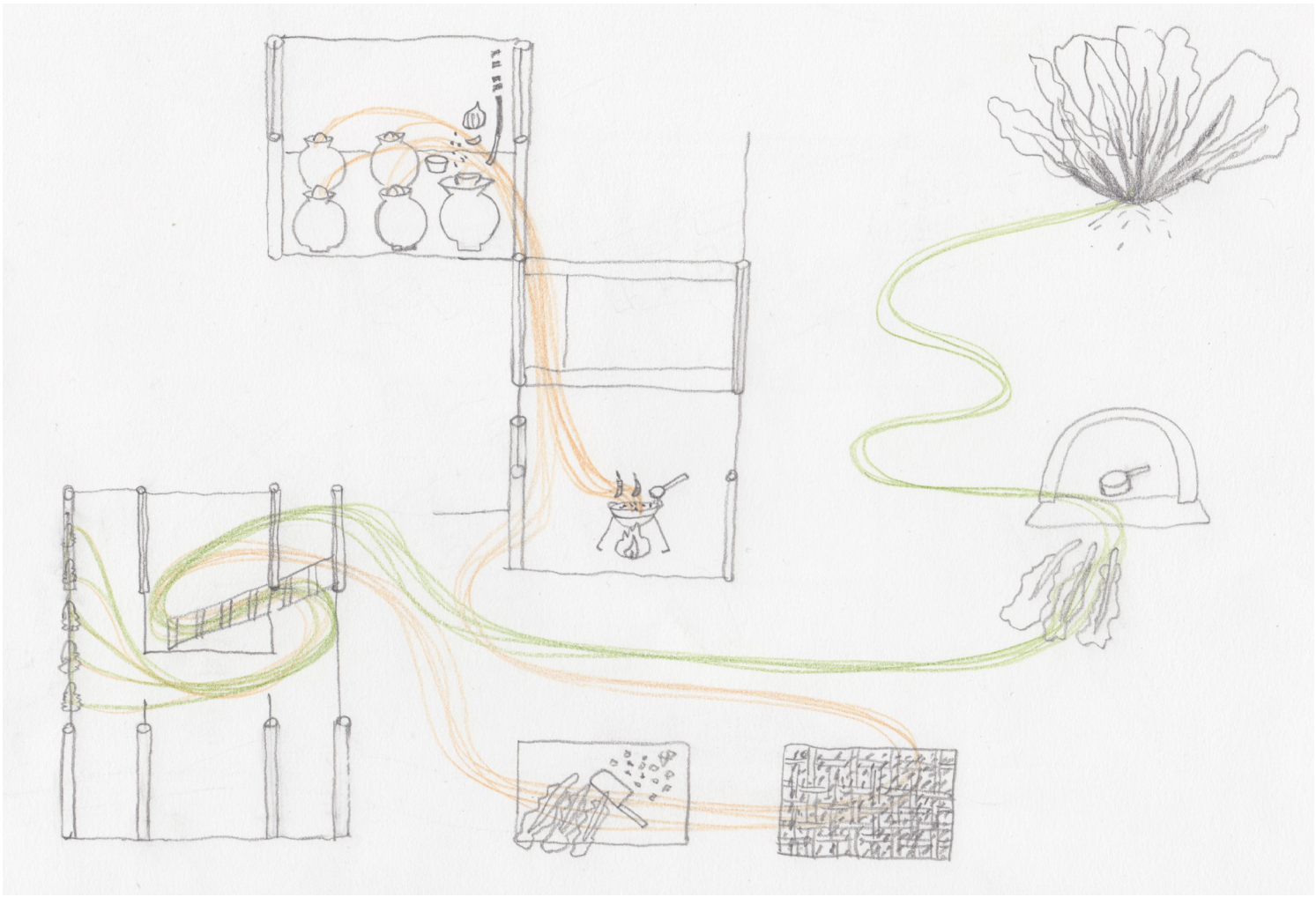

83

Life cycle of pickled vegetables



Duanwu Dragon Festival  
June

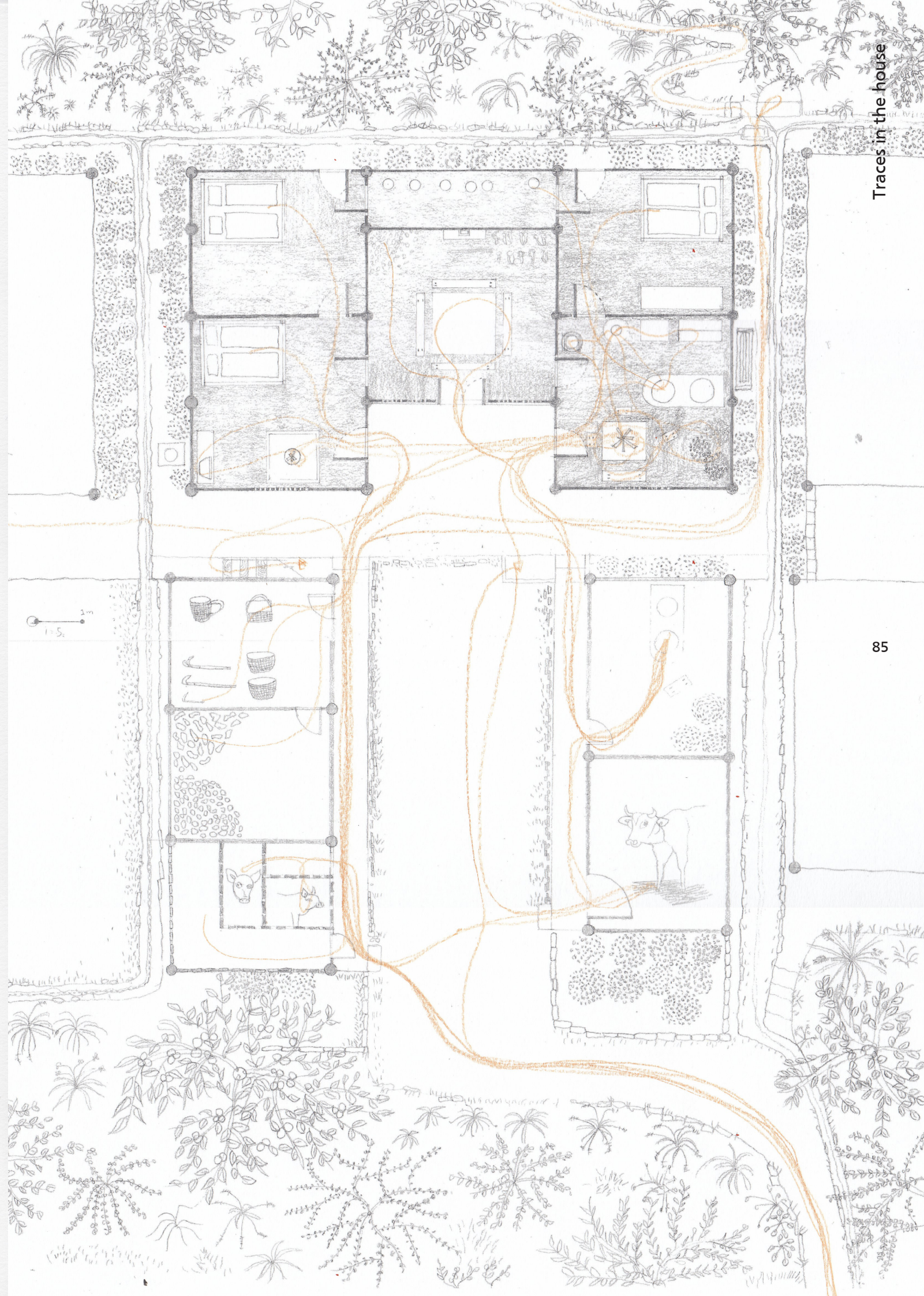
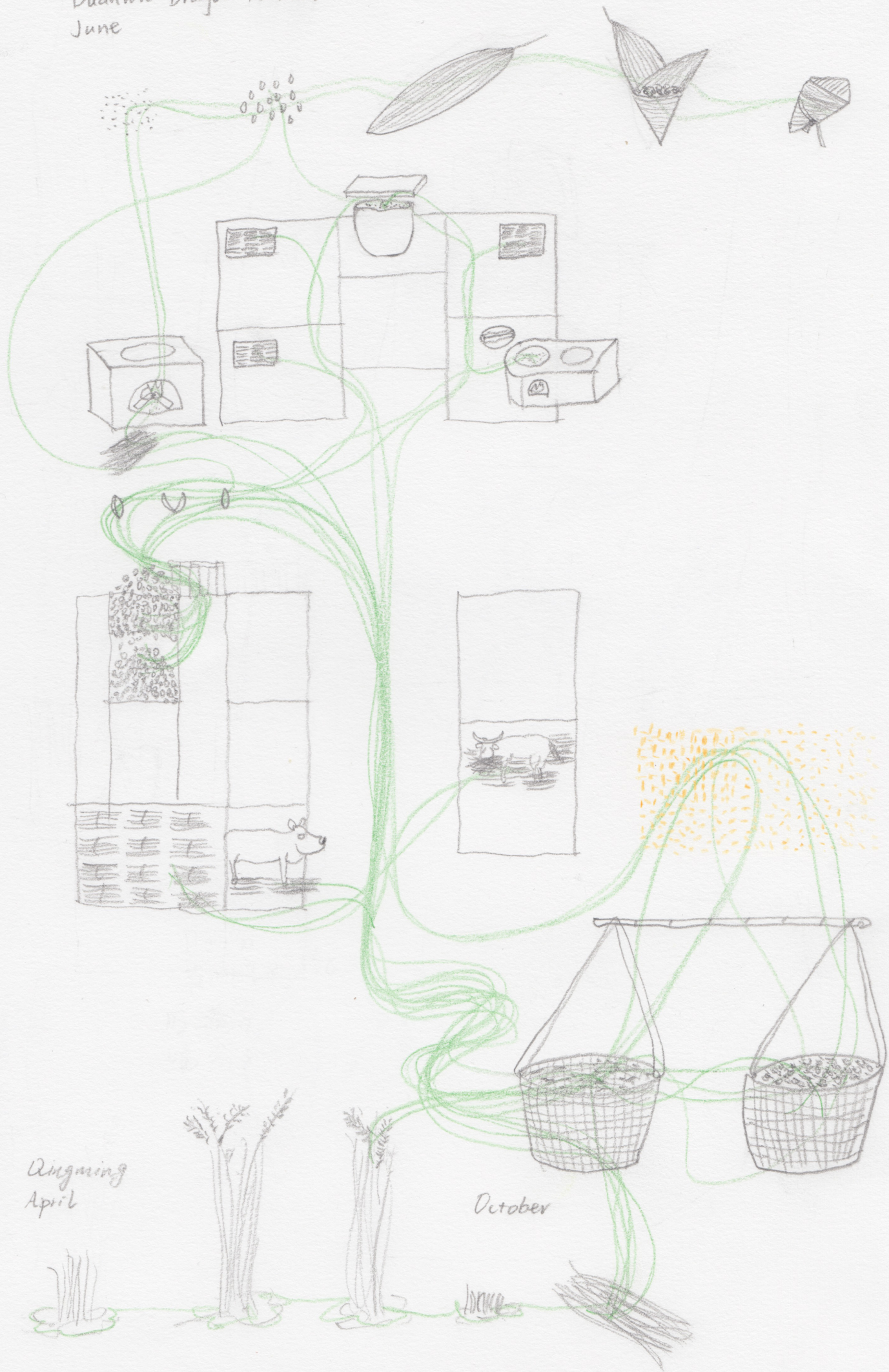







# LIVING WITH FLORA

Growing House 90 - 93

Villopedia Life 94 - 95

Scenarios + Furniture Design 96 - 105

Gardens 106 - 113

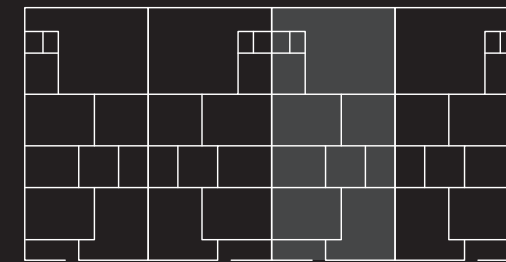



Growing House

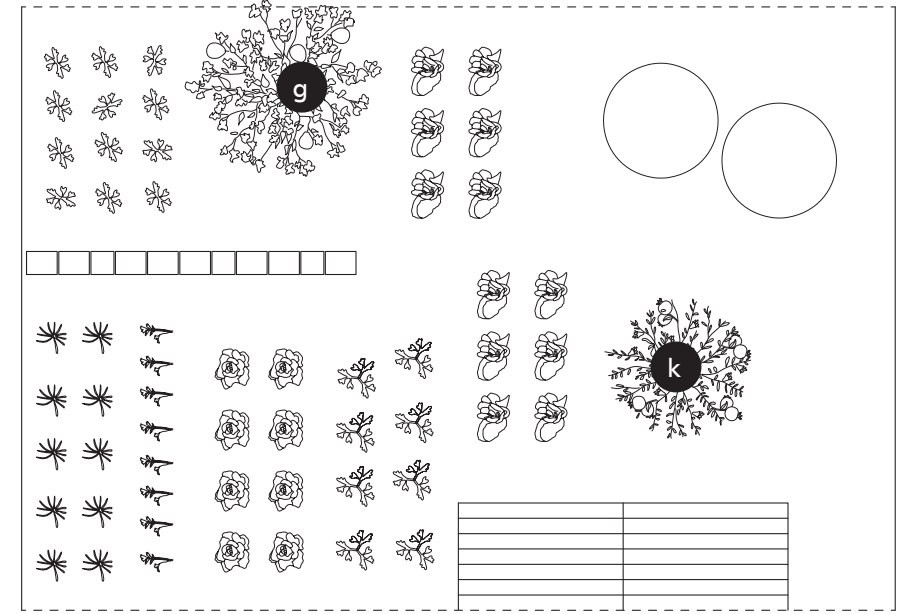
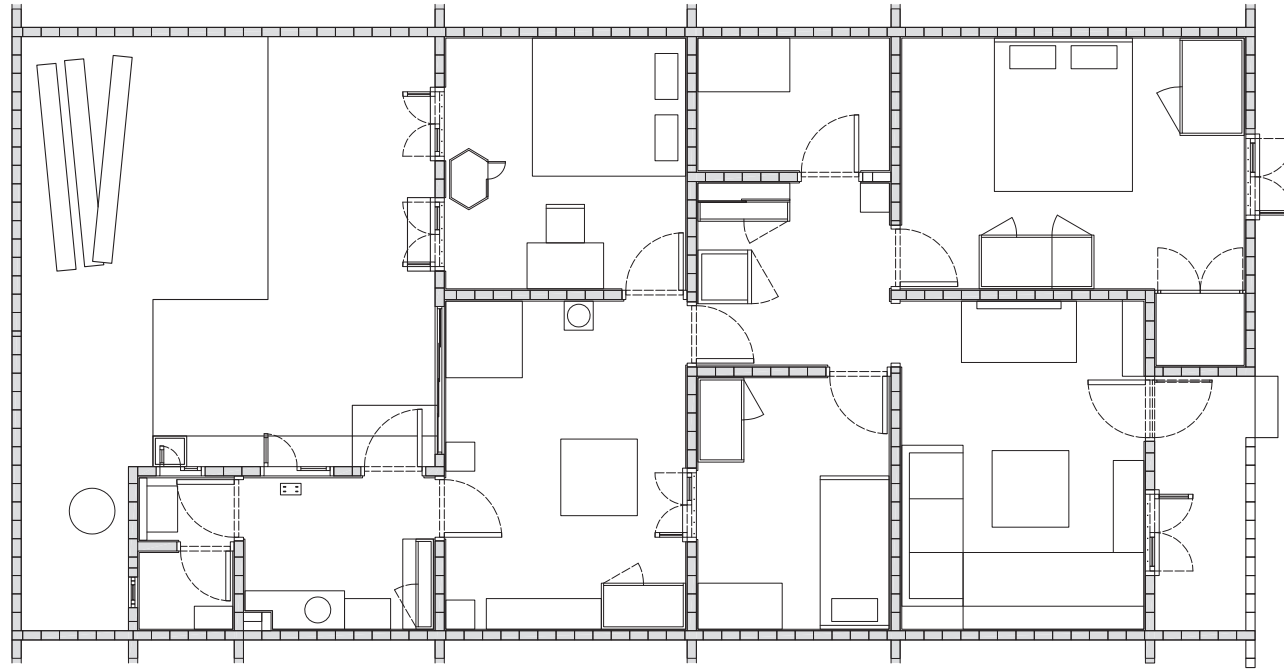

2023

90

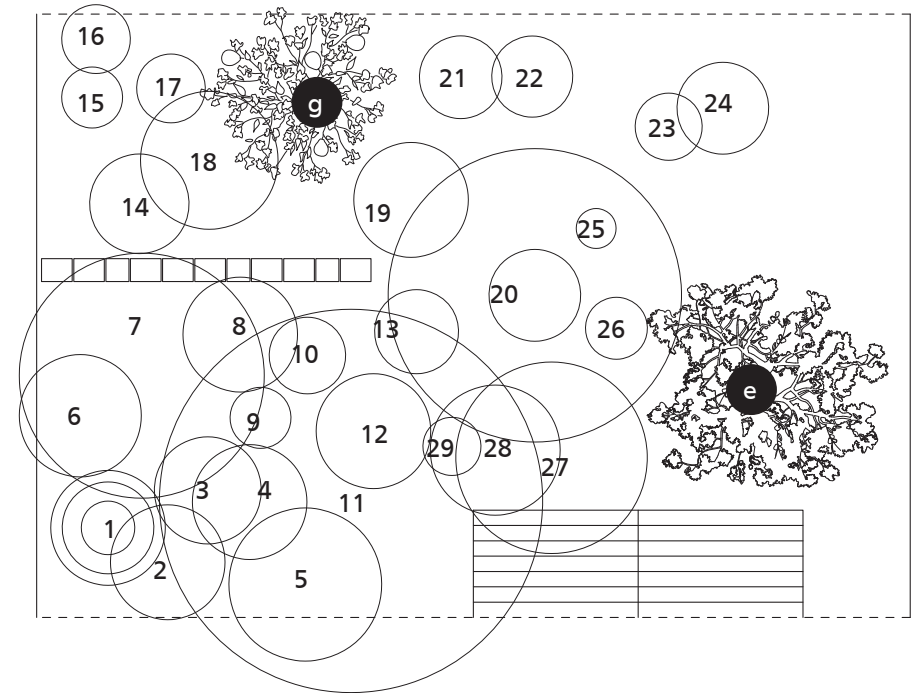

2022

91

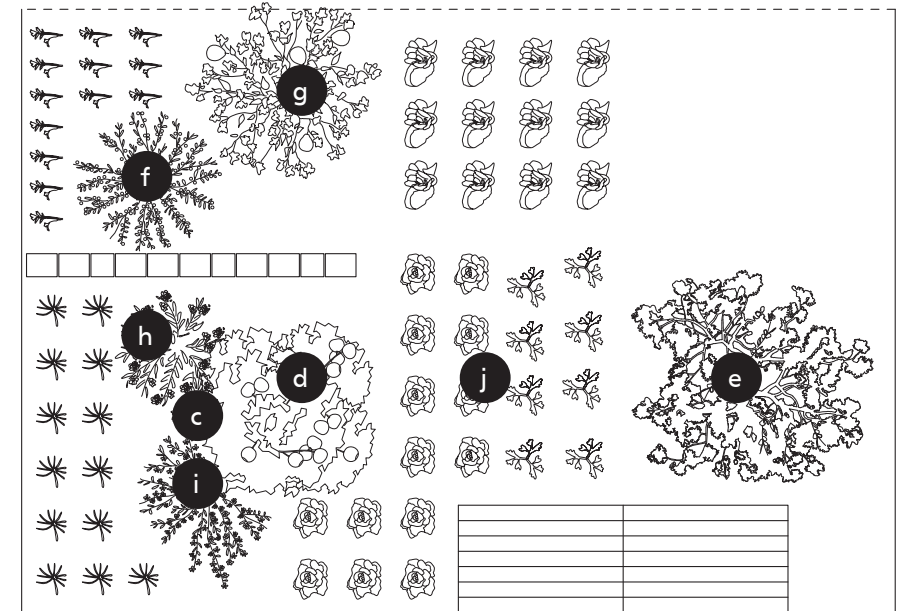
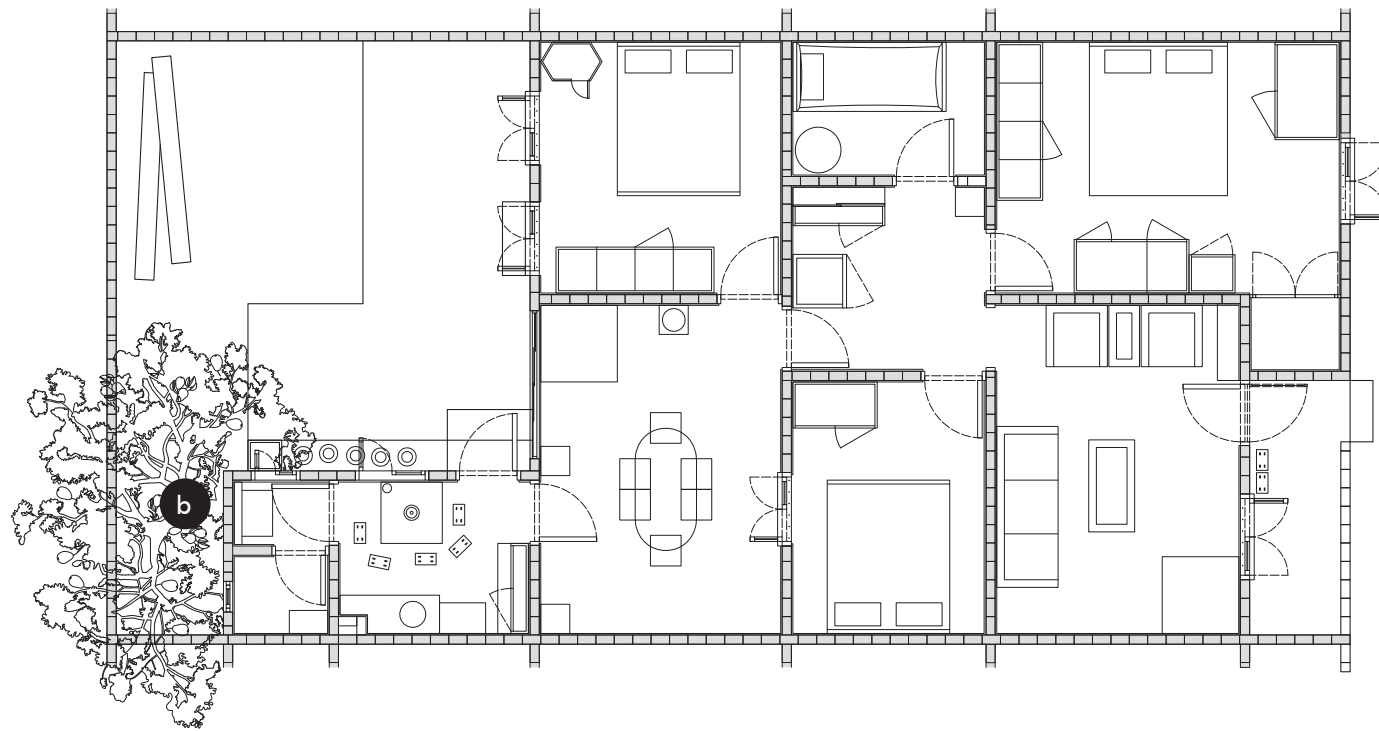

2000



### 2000 Food value

a	桂花树	Sweet Osmanthus / Osmanthus fragrans
b	梨树	Pear Tree / Pyrus pyrifolia
c	葡萄树	Grape / Chardonnay
d	橘子树	Clementine Tree
e	枣子树	Ziziphus Jujuba
f	杨梅树	Chinese Bayberry / Myrica Rubra
g	柚子树	Pomelo Tree / Citrus maxima
h	紫薇花	Common Crepe Myrtle / Lagerstroemia indica
i	迎春花	Winter Jasmine / Jasminum nudiflorum
j	蔬菜	Seasonal vegetables

### 2022 Ornamental value

1	山叶互生赤楠	Syzygium buxifolium
2	雀舌叶赤楠	Syzygium buxifolium
3	金弹子	Diospyros cathayensis
4	金弹子	Diospyros cathayensis
5	金弹子	Diospyros cathayensis
6	雀舌叶赤楠	Syzygium buxifolium
7	紫薇	Common Crepe Myrtle / Lagerstroemia indica
8	金弹子	Diospyros cathayensis
9	金弹子	Diospyros cathayensis
10	金弹子	Diospyros cathayensis
11	马里光/银薇	Lagerstroemia indica L. f. alba (Nichols.) Rehd.
12	两叶对生赤楠	Syzygium buxifolium
13	金弹子	Diospyros cathayensis
14	红豆杉	Taxus wallichiana var. chinensis (Pilger) Florin
15	黄杨	Buxus sinica
16	金弹子	Diospyros cathayensis
17	黄杨	Buxus sinica
18	金弹子	Diospyros cathayensis
19	金弹子	Diospyros cathayensis
20	紫薇	Lagerstroemia indica
21	继木	Loropetalum chinense (R. Br.) Oliv.
22	赤楠	Syzygium buxifolium
23	赤楠	Syzygium buxifolium
24	黄杨	Buxus sinica
25	赤楠	Syzygium buxifolium
26	继木	Loropetalum chinense (R. Br.) Oliv.
27	金弹子	Diospyros cathayensis
28	金弹子	Diospyros cathayensis
29	金弹子	Diospyros cathayensis

### 2023 Food value

a	桂花树	Sweet Osmanthus / Osmanthus fragrans
g	柚子树	Pomelo Tree / Citrus maxima
j	蔬菜	Seasonal vegetables
k	石榴树	Pomegranate Tree / Punica granatum



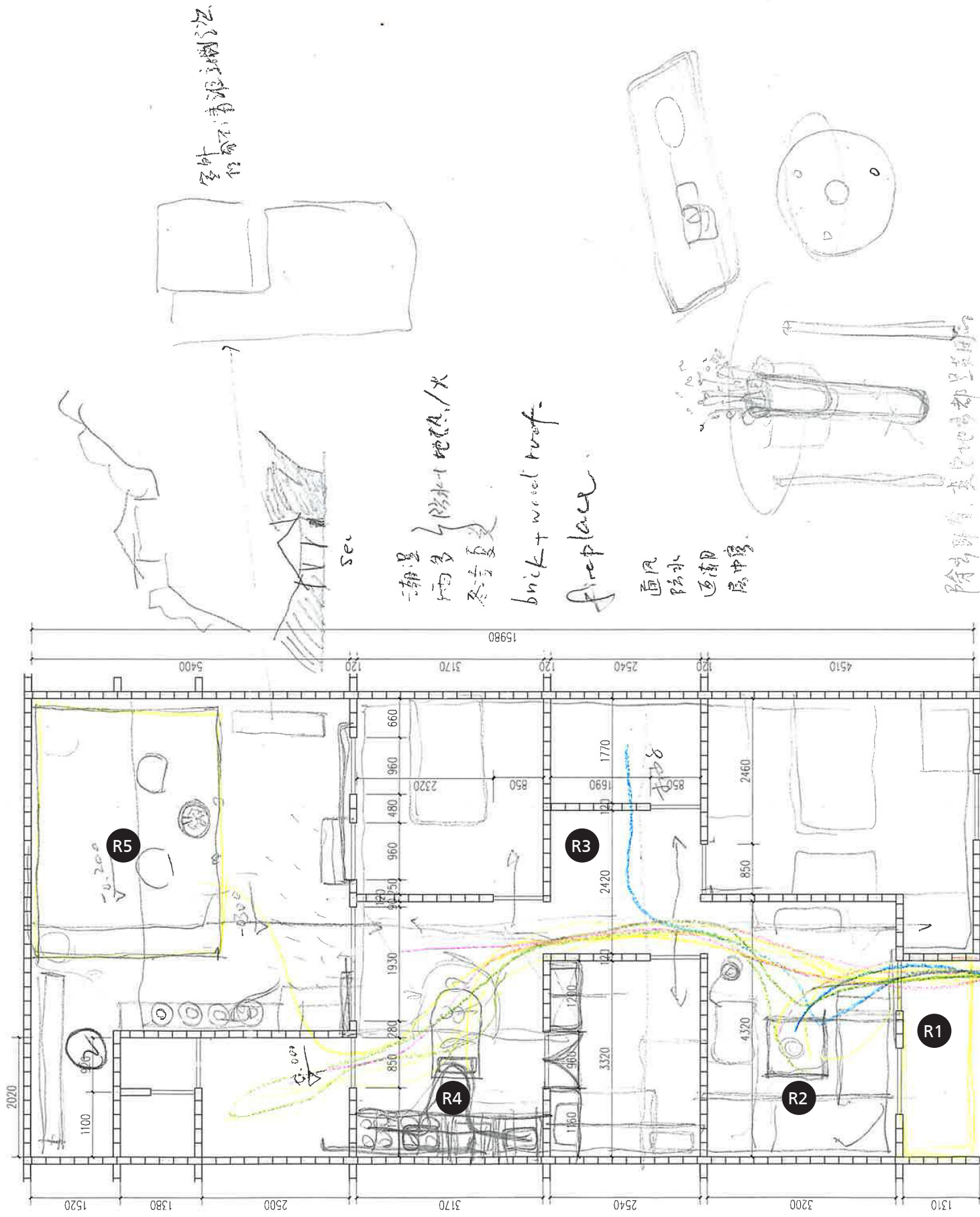

Live with Flora

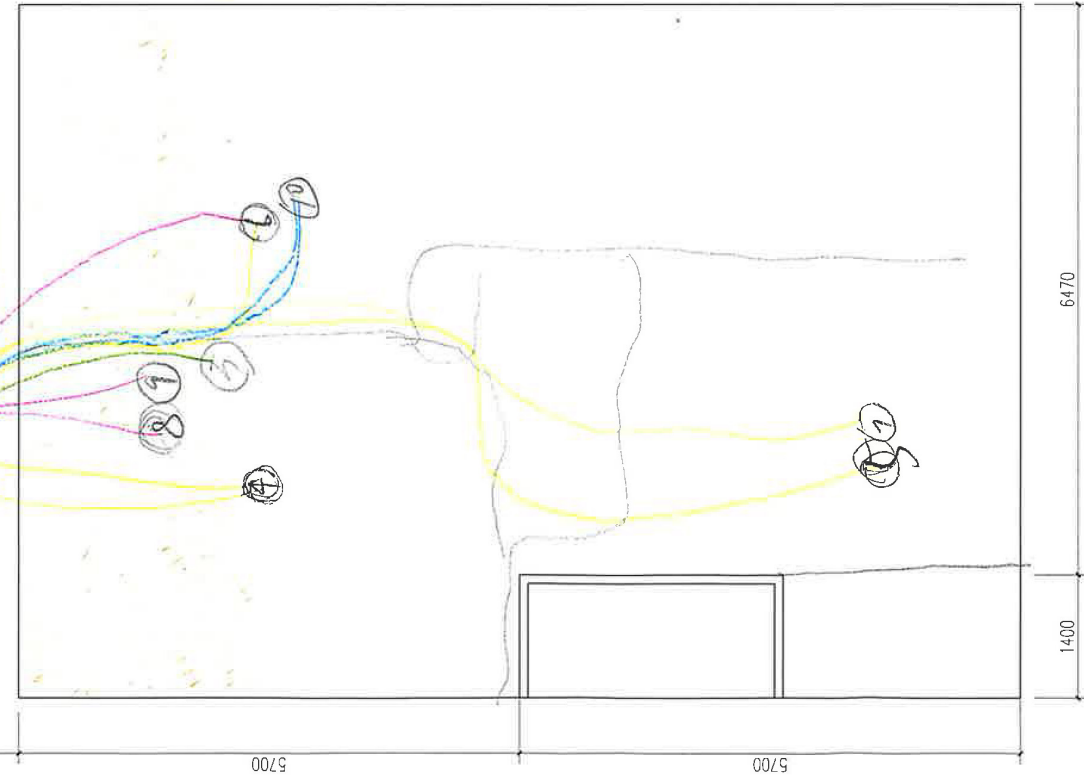

- 1 桃树 Sweet Olive / Sweet Osmanthus (E) (AU)
  - 2 梨树 Pear tree (AU)
  - 3 葡萄 grape (SU)
  - 4 橘 Mandarinian (AU)
  - 5. 枣树 Chinese jujube (AU)
  - 6. 杨梅 Chinese bayberry (SP)
  - 7. 石榴 Pomegranate tree (N) (AU)
  - 8 紫葡萄 grape myrtle (SP)
  - 9. 迎春花 winter jasmine (SP)
  - 10. 柚子 Pomelo tree (WT) (E)
  - 11. 青桔 exist. (Green Exotic WT)
- N new-plant  
 SP SU AU WT



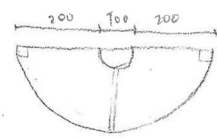
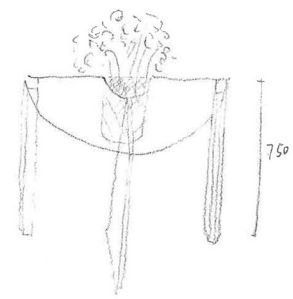

1-3 Semi-table in Semi-outdoor  
Cedar, bamboo or rattan woven  
waterproof oil

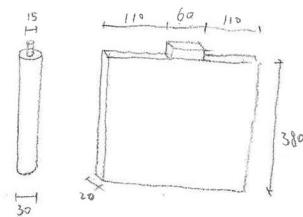
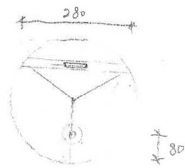
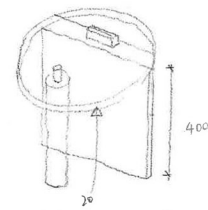

1-4 Semi-chair in Semi-outdoor  
Cedar, water proof oil

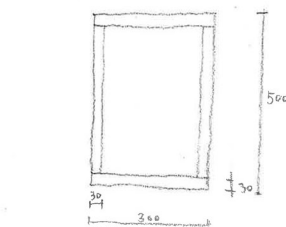
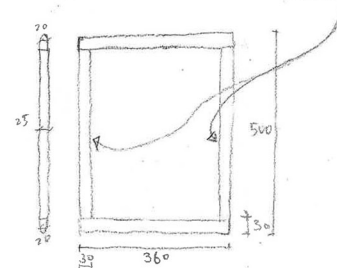
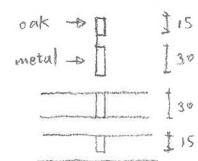
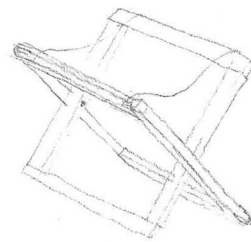

1-5 Semi-chair in Semi-outdoor  
Oak, metal, fabric

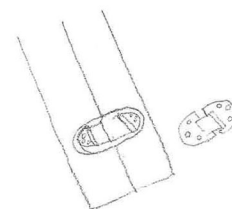
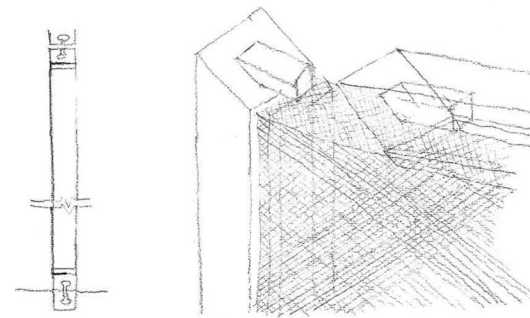
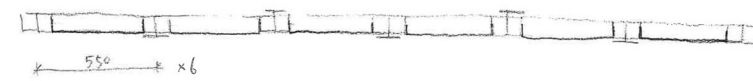
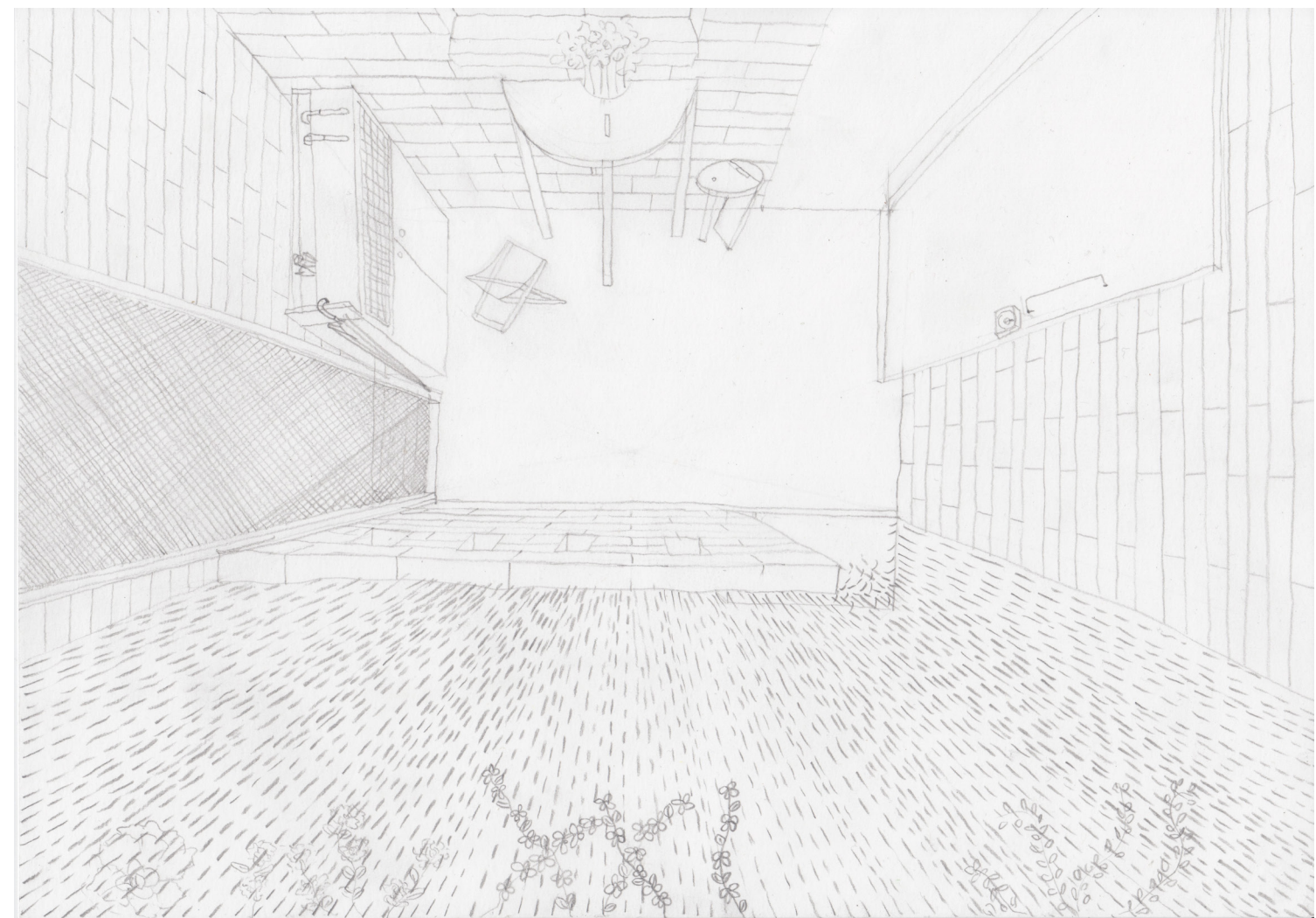

1-1 Net-Door  
cedar, net  
waterproof oil

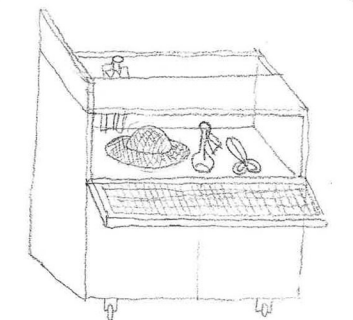
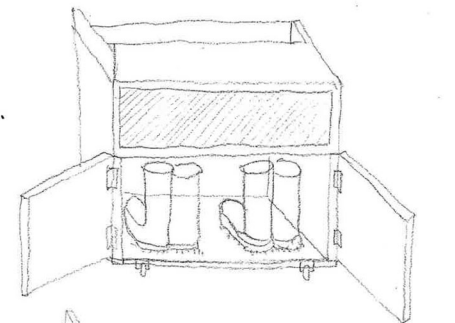
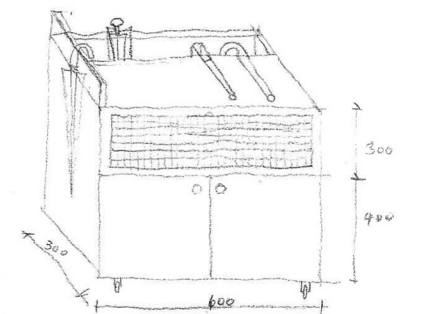

1-2 Outdoor Cabinet  
fir Plywood, bamboo,  
waterproof oil



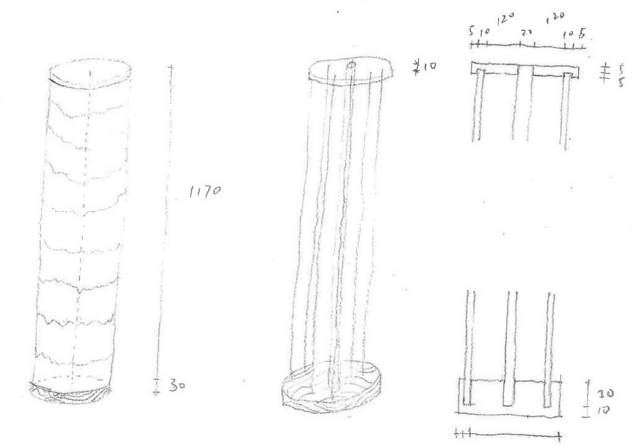
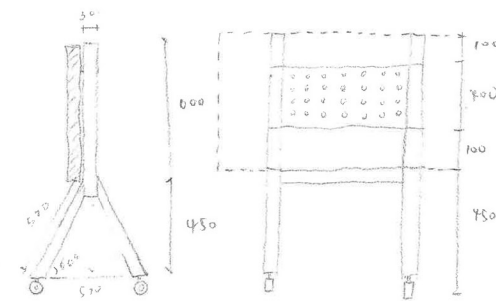
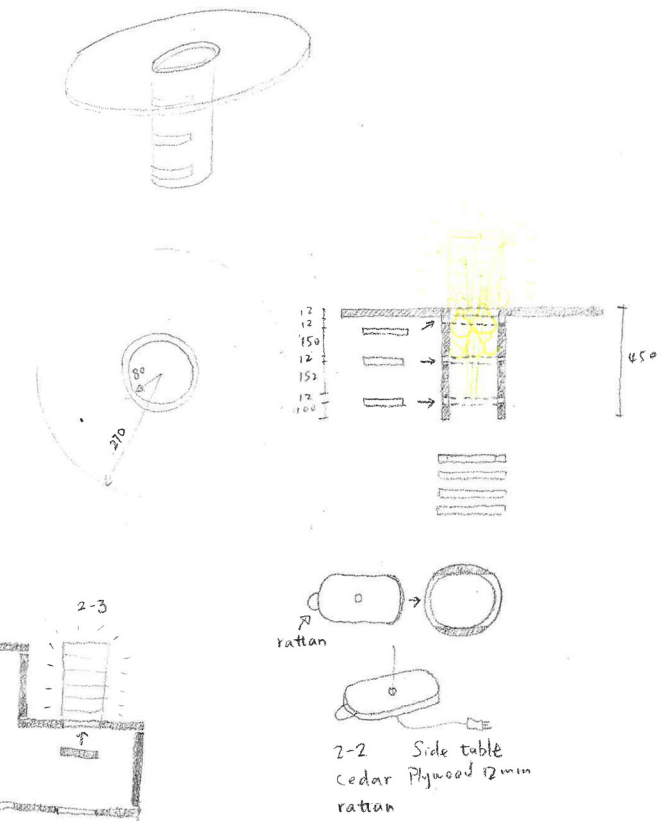
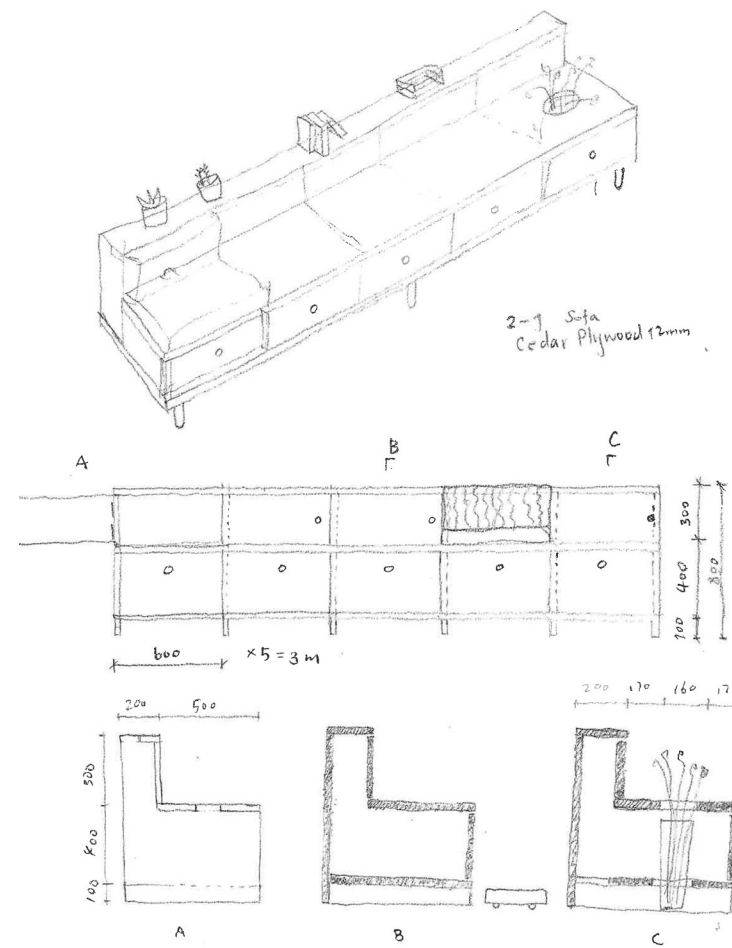
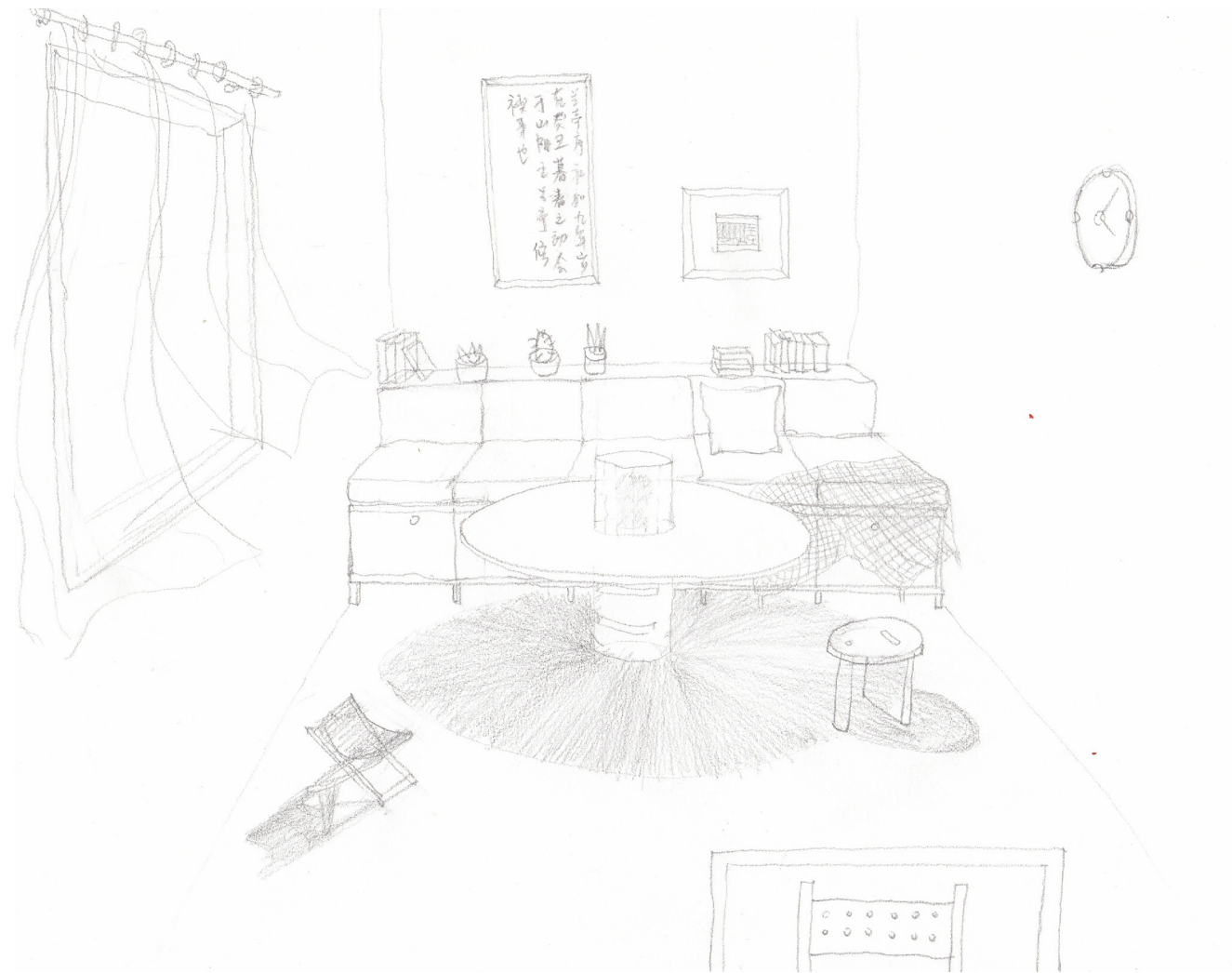

2-3 Television stand  
cedar, screw, roller, plate

2-5 Stand Lamp  
Cedar, wire, rice paper  
led neon light.

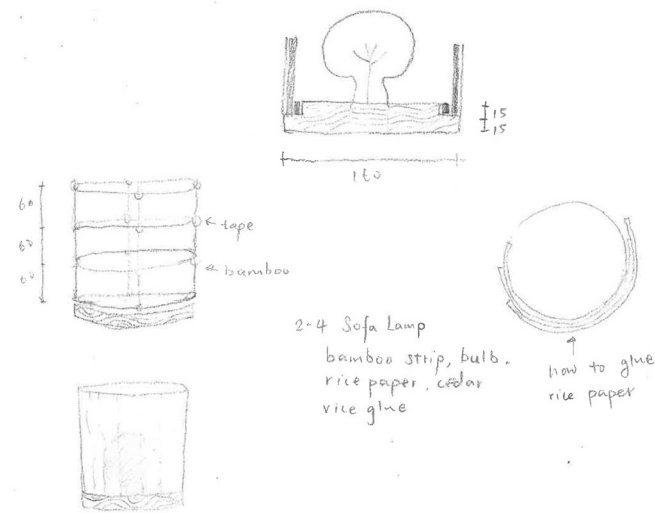

2-4 Sofa Lamp  
bamboo strip, bulb,  
rice paper, cedar,  
vice glue



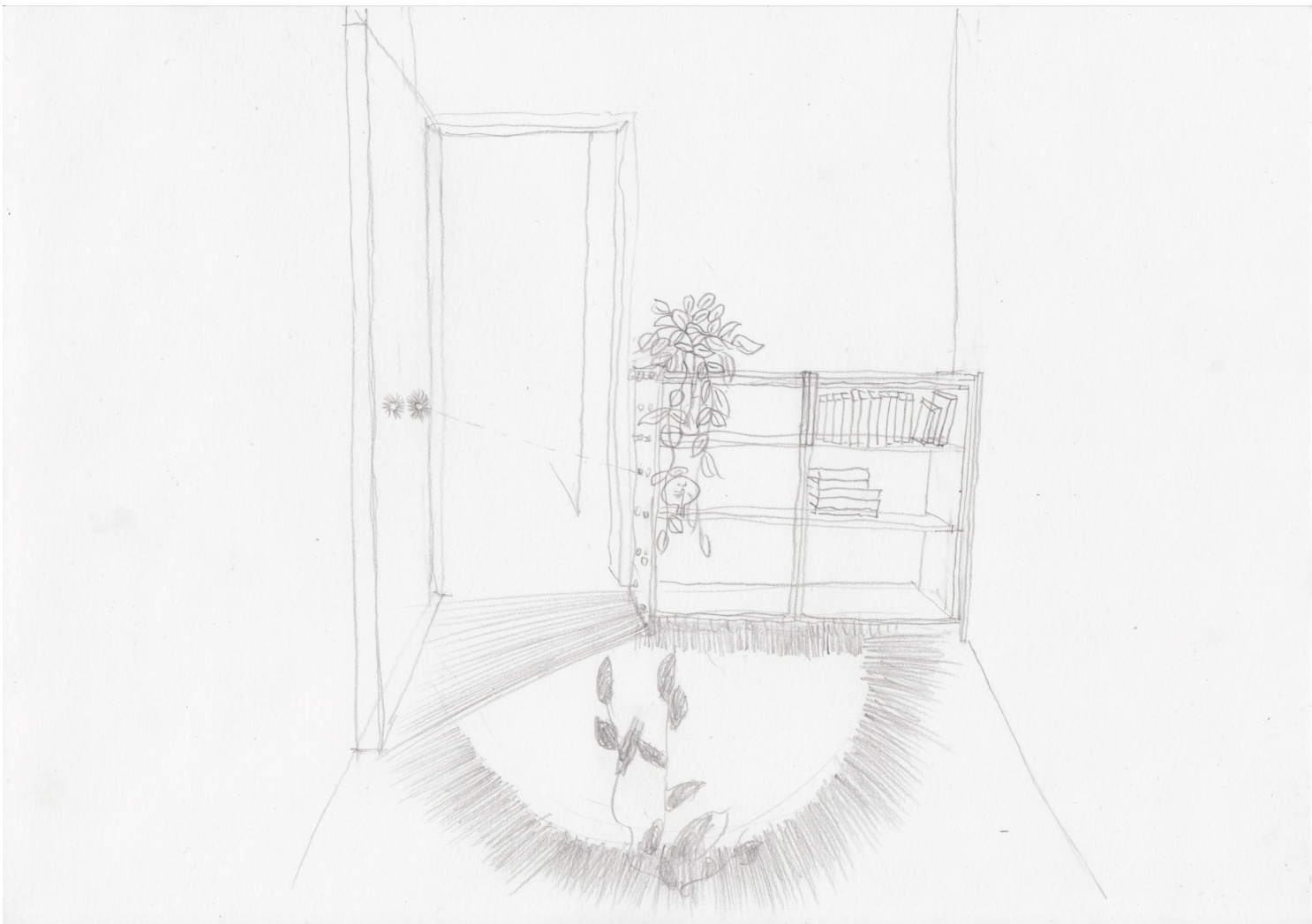

100

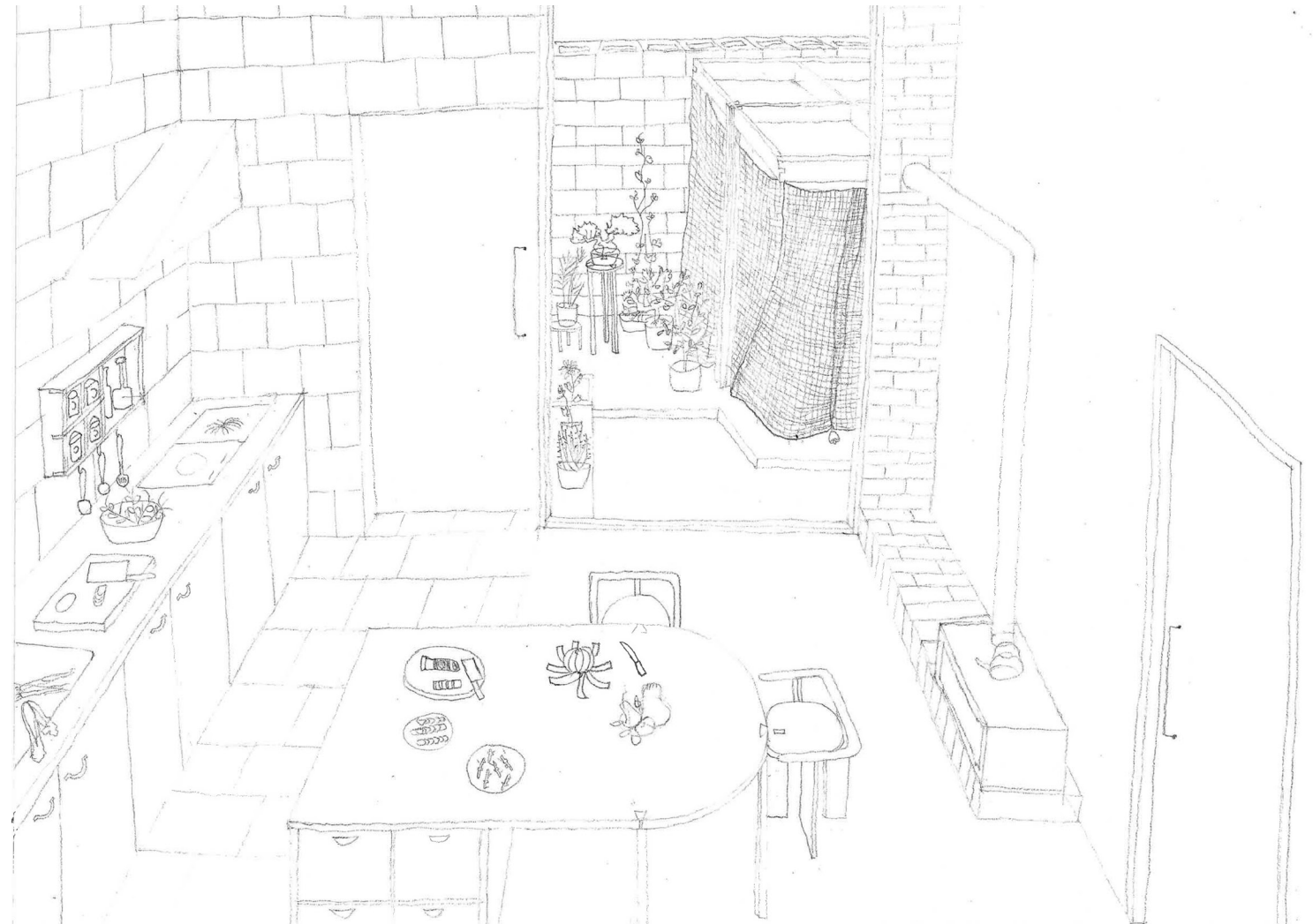

101

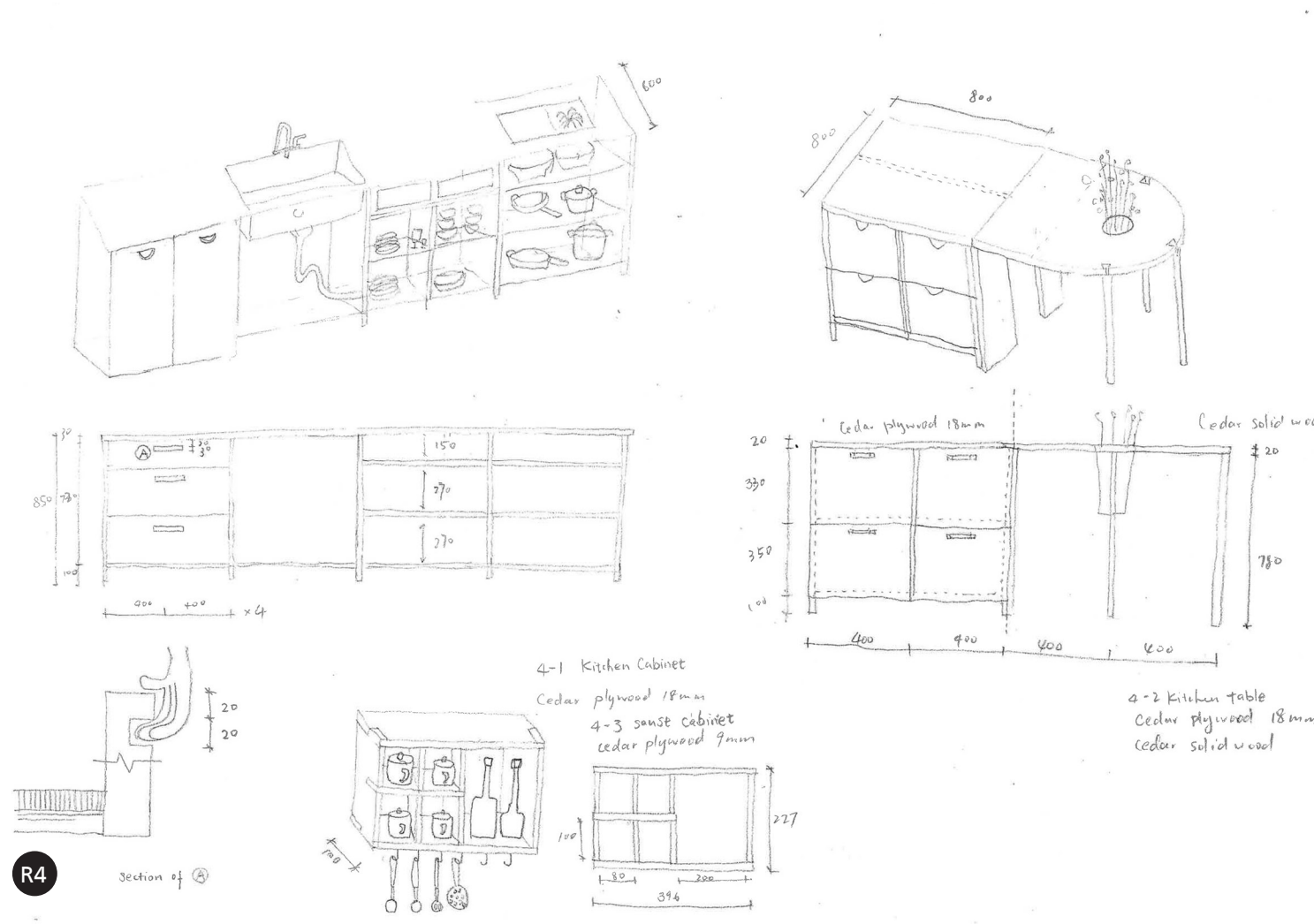
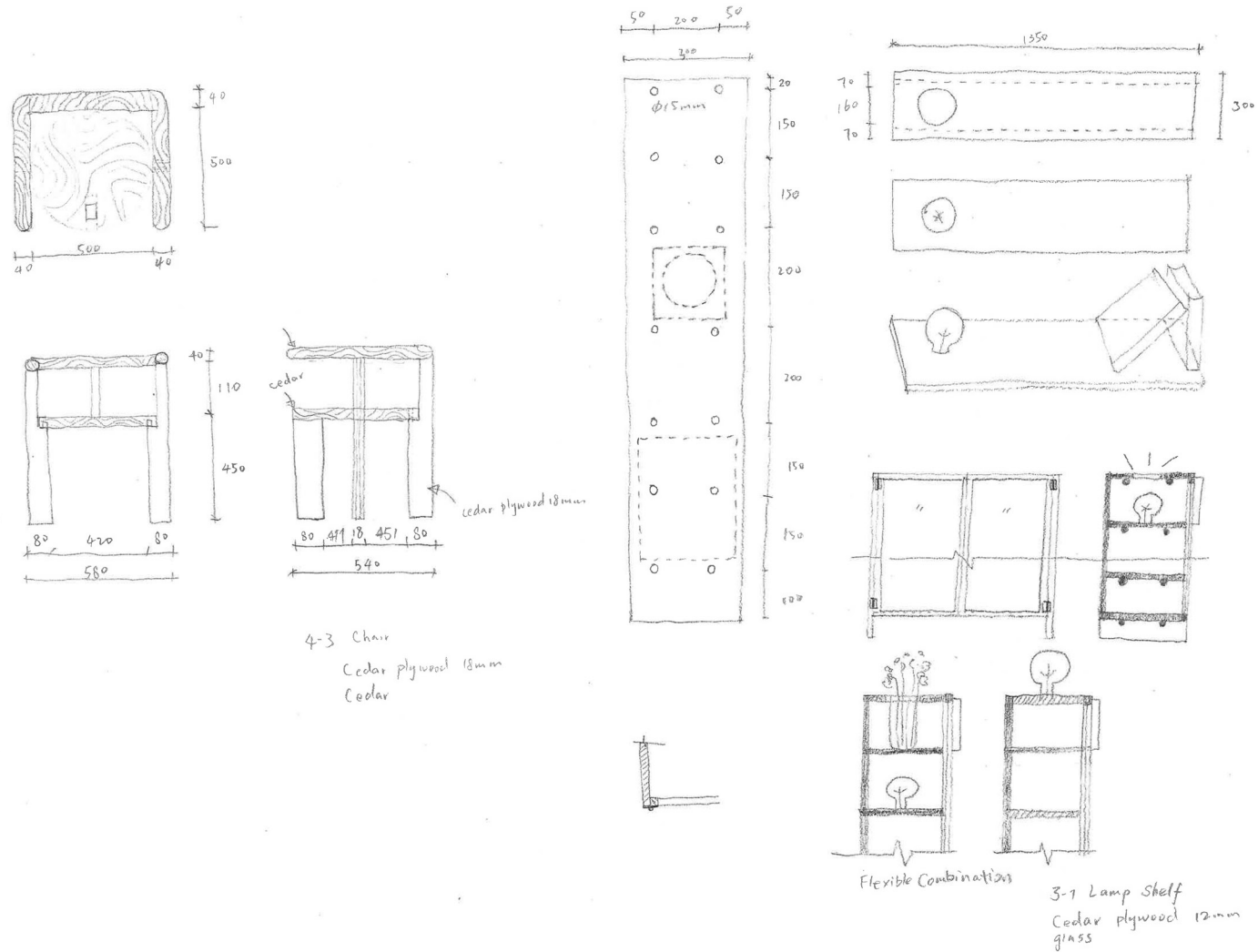

R3

R4



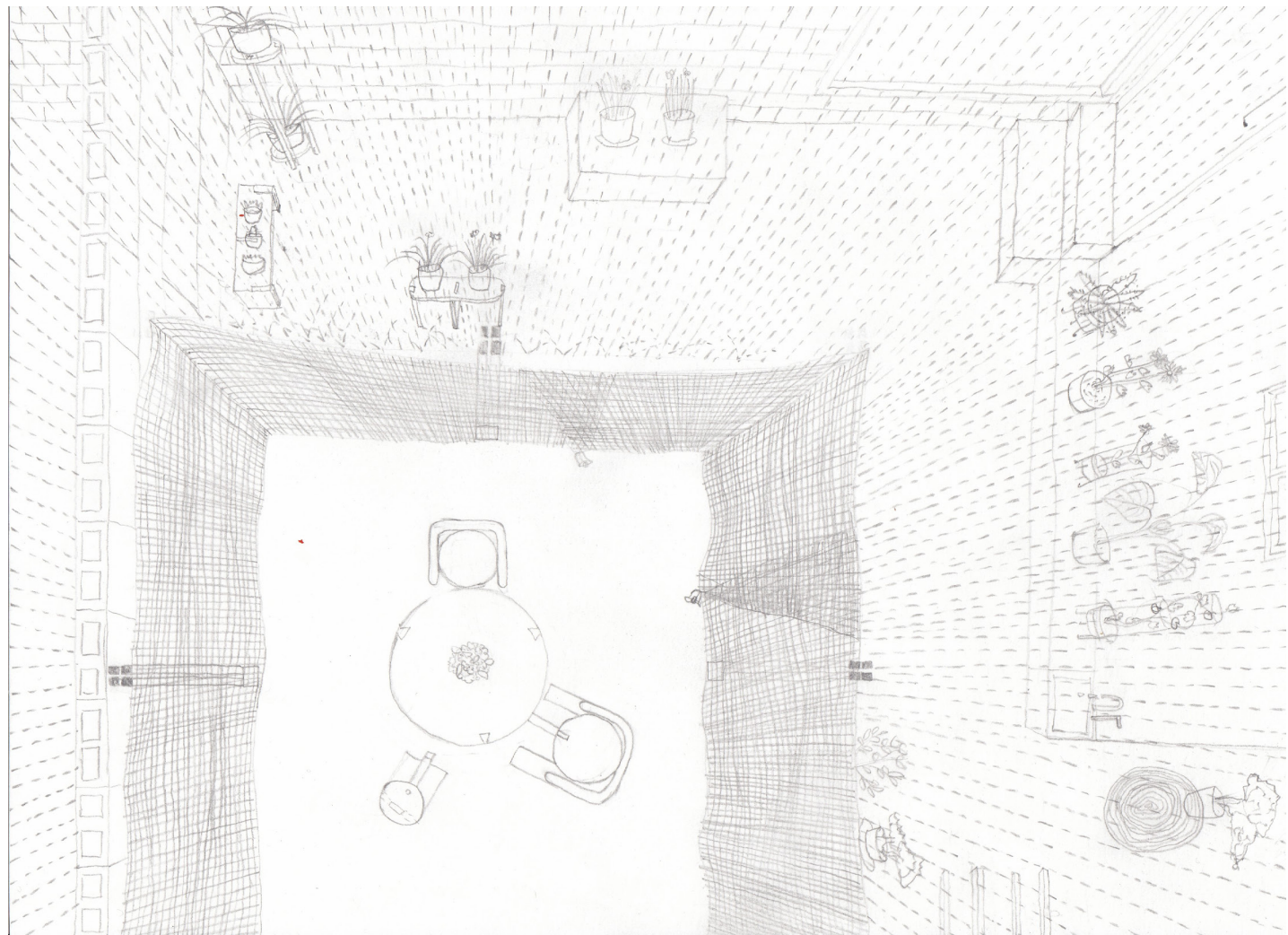

102

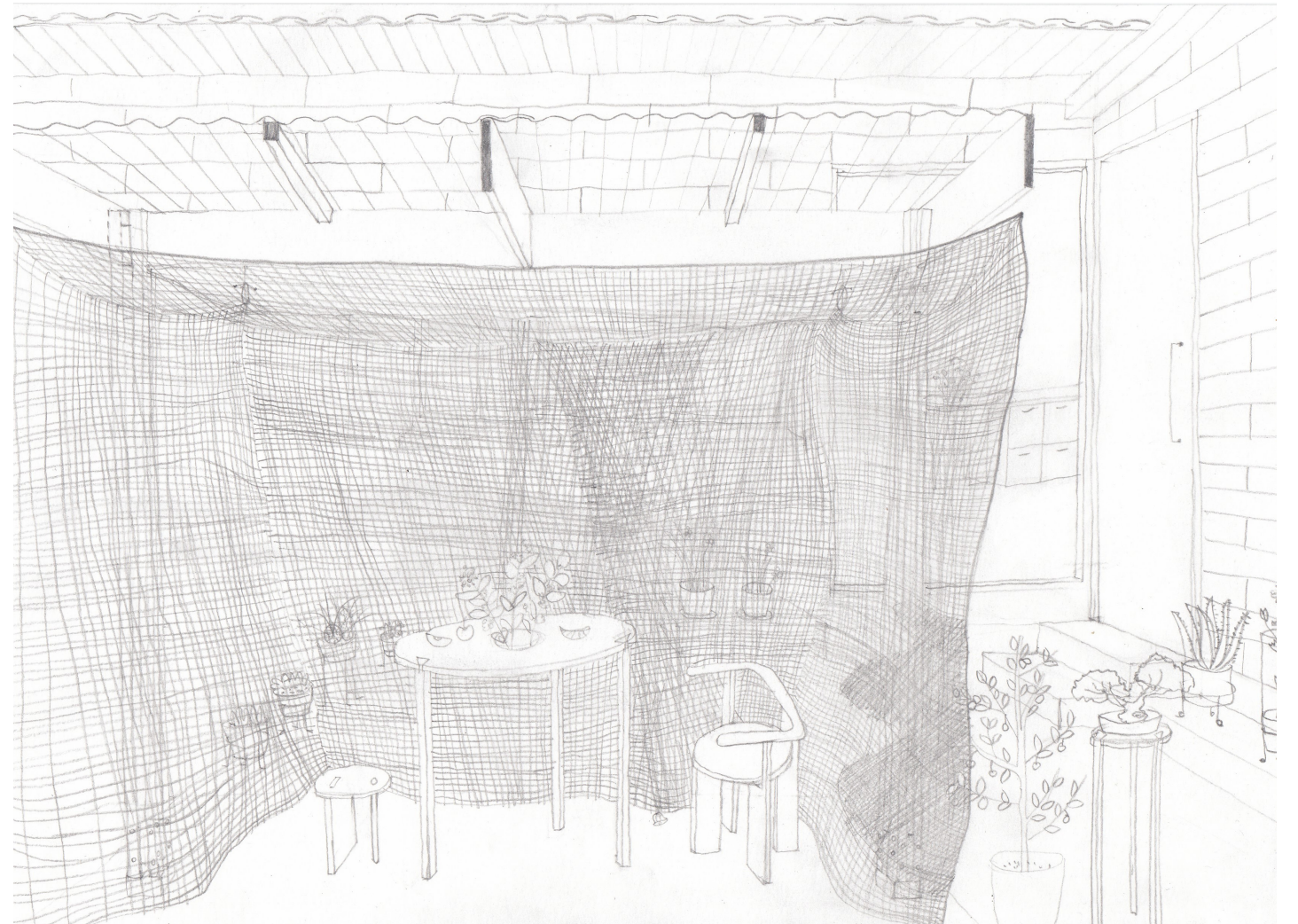

103

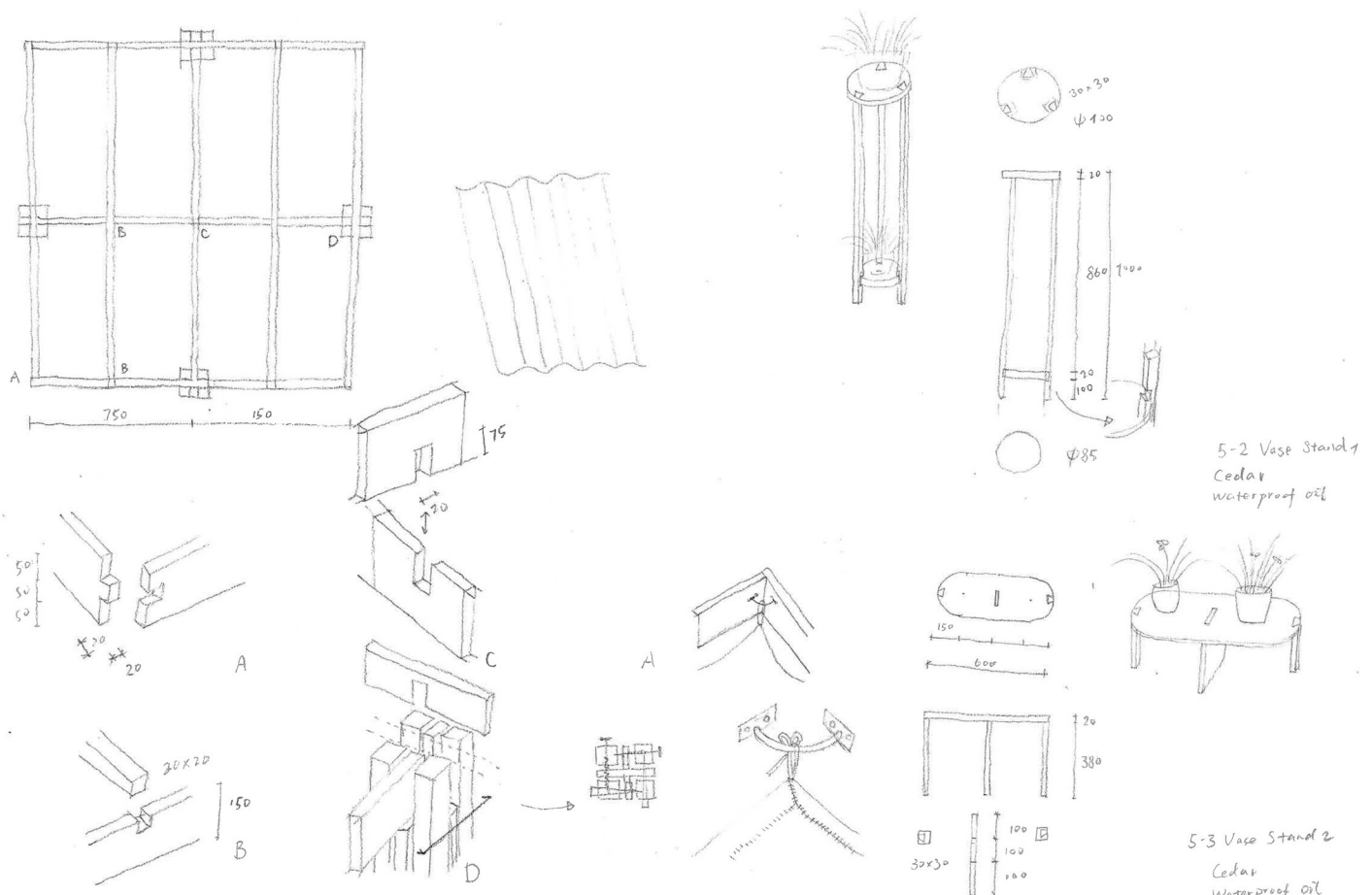

5-1 No Mosquito!  
Net Pavilions!  
Cedar 50x50x2000  
Cedar plywood 20x150  
Polycarbonate roof

5-2 Vase Stand 1  
Cedar  
waterproof oil

5-3 Vase Stand 2  
Cedar  
Waterproof oil

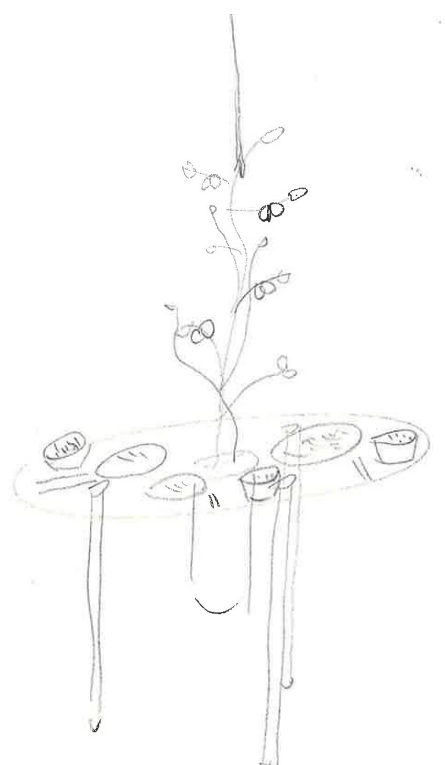
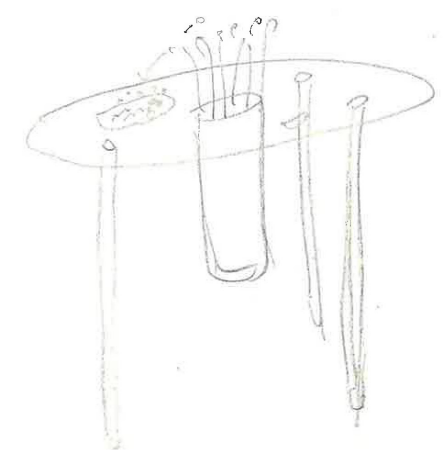

All the tables are where people  
sit together like as they did  
around fire place in the Blank Space

with plants

T-D  
19.11.03







# Gardens

- Spring
- Summer
- Autumn
- Winter

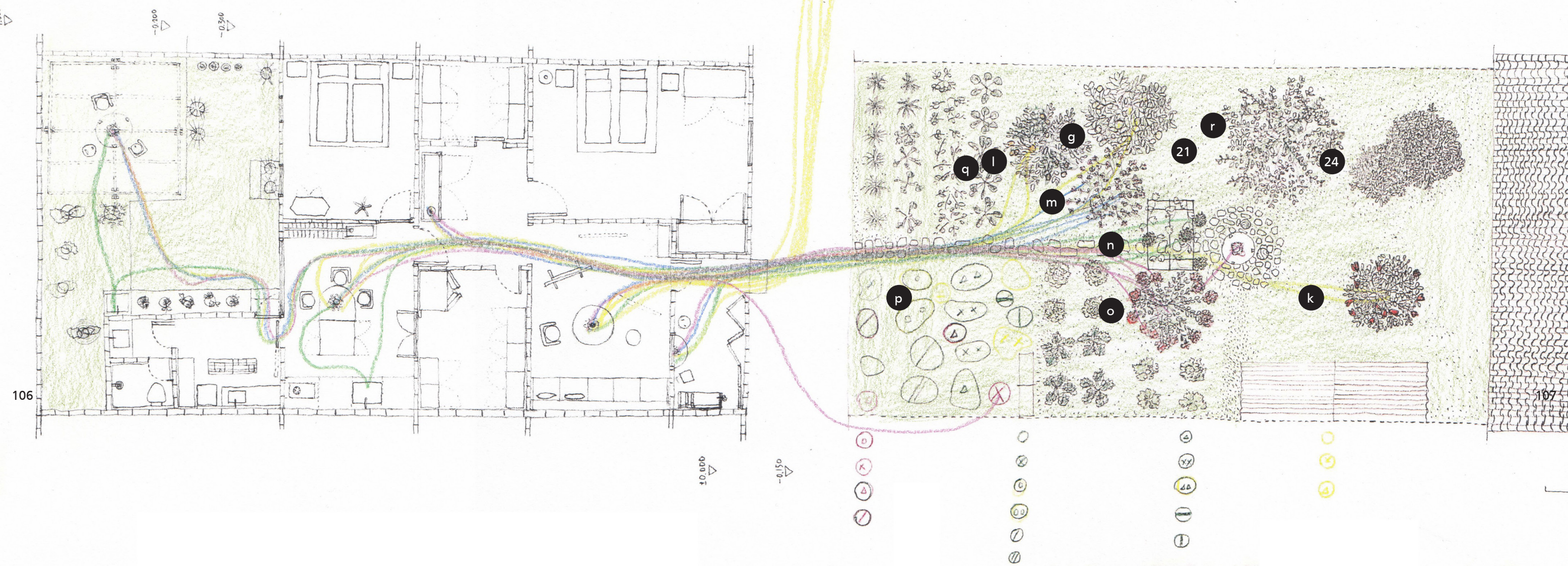



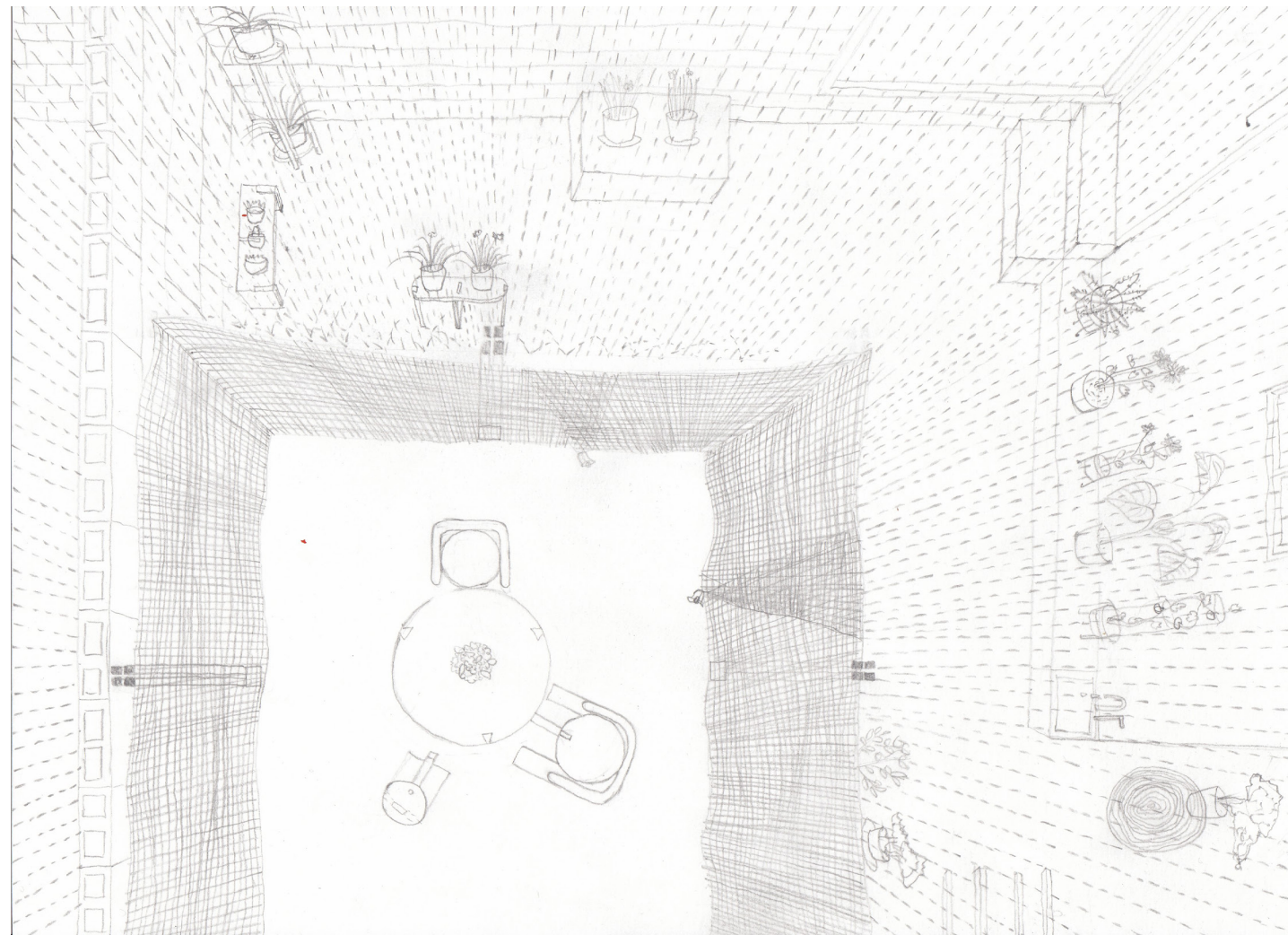

108

Gardens - The orchid room



兰花

Orchid



菊花

Chrysanthemums



松

Pine



109

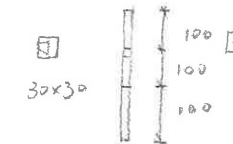
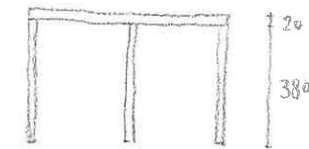
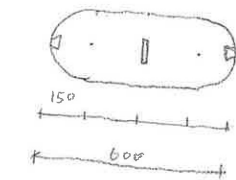
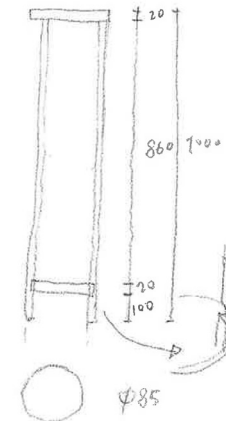
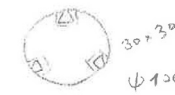
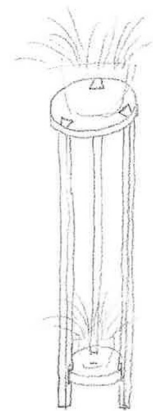

5-2 Vase Stand 1  
Cedar  
waterproof oil

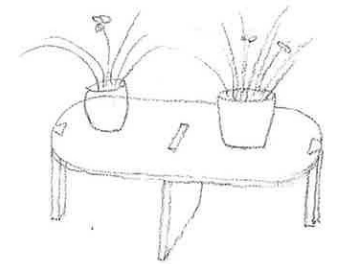

5-3 Vase Stand 2  
Cedar  
Waterproof oil



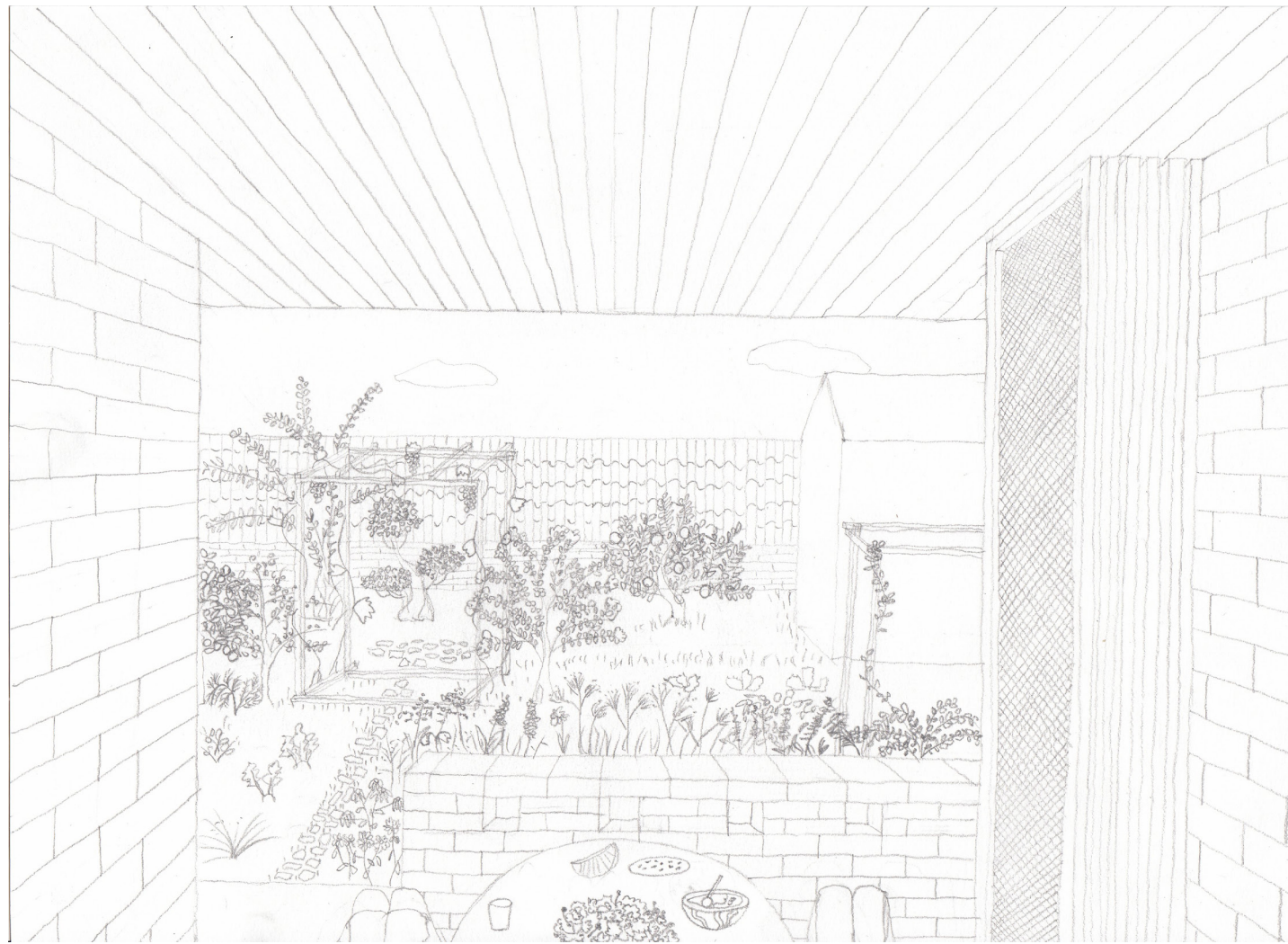

Gardens - The herbs room with theoretical planting

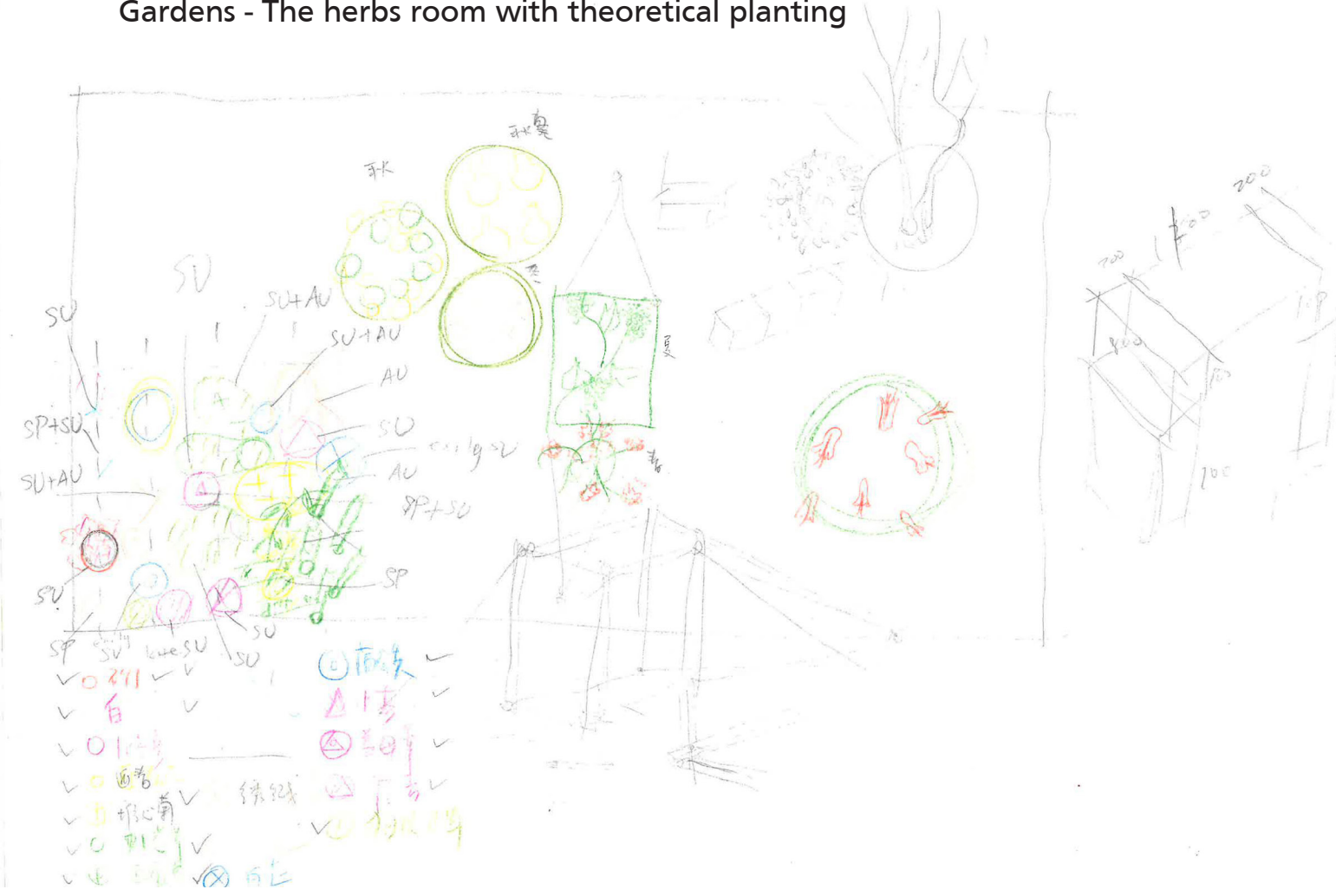



Spring Summer Autumn Winter

Food value	g	柚子树	Pomelo Tree / <i>Citrus maxima</i>	
	j	蔬菜	Seasonal vegetables	
	k	石榴树	Pomegranate Tree / <i>Punica granatum</i>	
	l	橘子树	<i>Citrus reticulata</i>	
	n	葡萄树	Grape	
	Ornamental value	a	桂花树	Sweet Osmanthus / <i>Osmanthus fragrans</i>
		m	梅树	<i>Prunus mume</i>
		o	紫薇	<i>Lagerstroemia indica</i>
		p	银杏	<i>Ginkgo biloba</i>
		q	肾蕨	<i>Nephrolepis cordifolia</i>
r	傅氏凤尾蕨	<i>Pteris guizhouensis</i> / <i>Pteris fauriei</i>		
21	继木	<i>Loropetalum chinense</i> (R. Br.) Oliv.		
24	黄杨	<i>Buxus sinica</i>		
	铃兰	Lily of the valley / <i>Convallaria keiskei</i> Miq.		

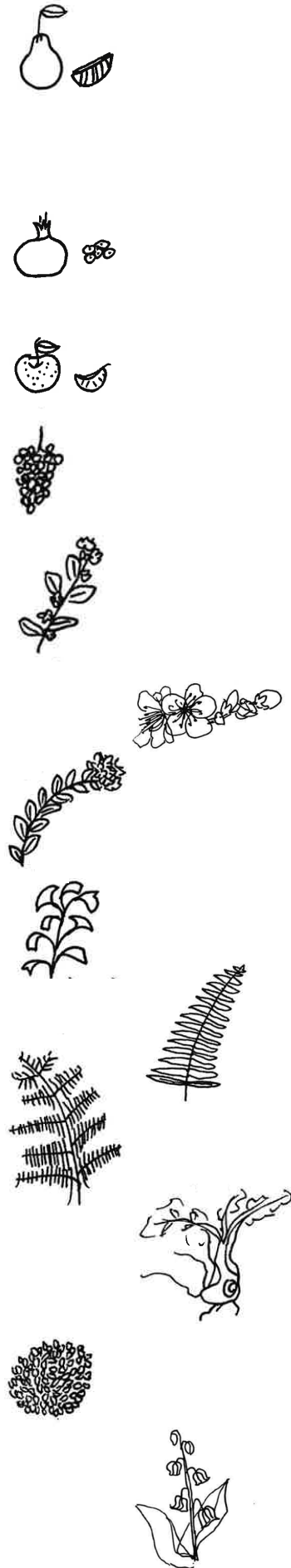

迎春花	Winter flower / <i>Jasminum nudiflorum</i>
水蓼	Water pepper / <i>Persicaria hydropiper</i>
马兰	<i>Aster indicus</i>
石竹	China pink / <i>Dianthus chinensis</i> L.
紫苑	Aster
野葵花	<i>Inula helianthus-aquatica</i> C. Y. Wu ex Ling
绣线花	<i>Spiraea blumei</i> G. Don
蒲公英	Dandelions / <i>Taraxacum</i>
狗尾巴草	<i>Setaria viridis</i>
抱茎蓼	<i>Bistorta amplexicaulis</i>
灯芯草	<i>Juncus effusus</i>
画眉草	<i>Eragrostis pilosa</i>
藿香	<i>Agastache rugosa</i>
白芷	<i>Angelica dahurica</i>
白苞蒿	<i>Artemisia lactiflora</i>
堆心菊	<i>Helenium bigelovii</i>





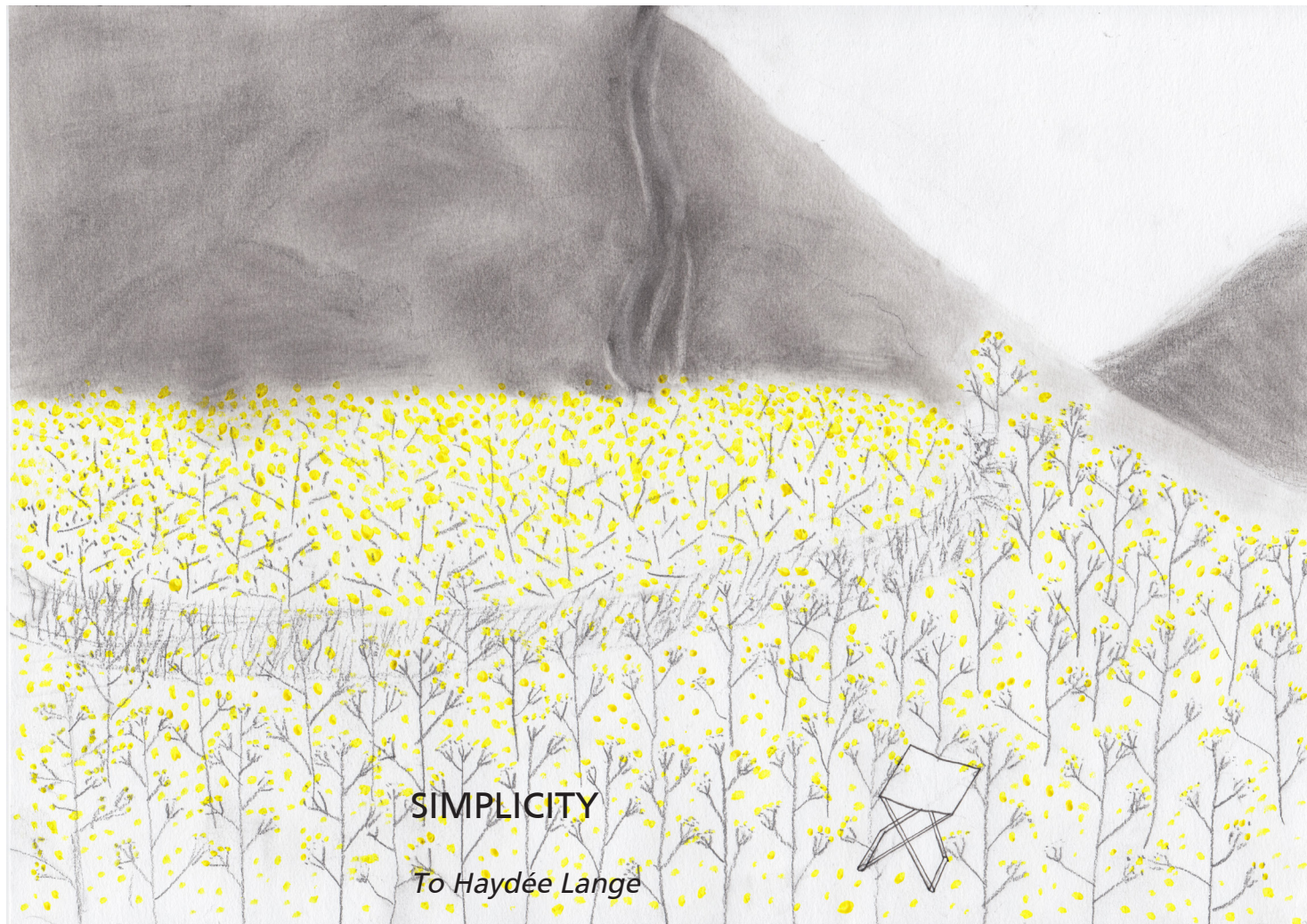

SIMPLICITY

To Haydée Lange

*Opens the garden gate  
docilely as a page  
a frequent devotion interrogates  
and inside the glance  
need not fix on objects  
now firmly in memory.  
I know each custom and soul  
and that dialect of allusions  
every human aggregation weaves.  
I need not speak  
nor lie about privileges;  
well they know me hereabouts,  
my anguish and weakness.  
This is as high as one may reach,  
what Heaven perhaps will grant us:  
**neither admiration nor victories  
but merely to be admitted  
as part of undeniable Reality  
like stones and trees.***

-- Jorge Luis Borges

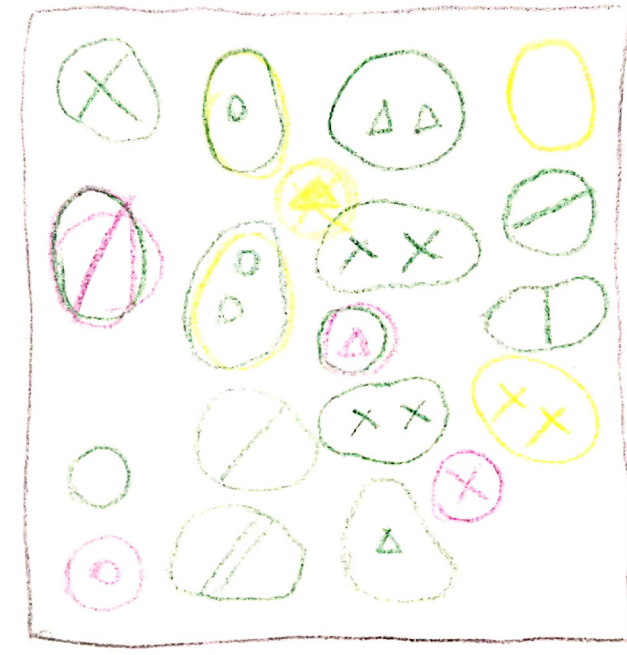

Villopia to be continued –

2024 One year initiative:  
Planting Herbs Room



VILLOPIA. THE PORTRAIT OF A VILLAGE



P R O C E S S



Sketches - Villopia

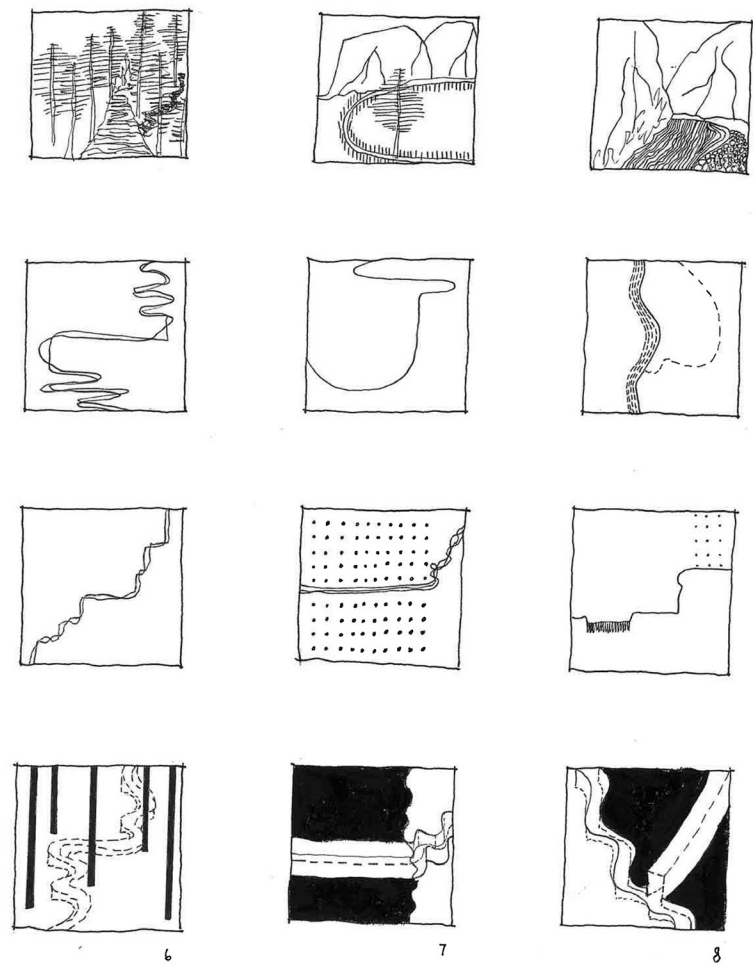
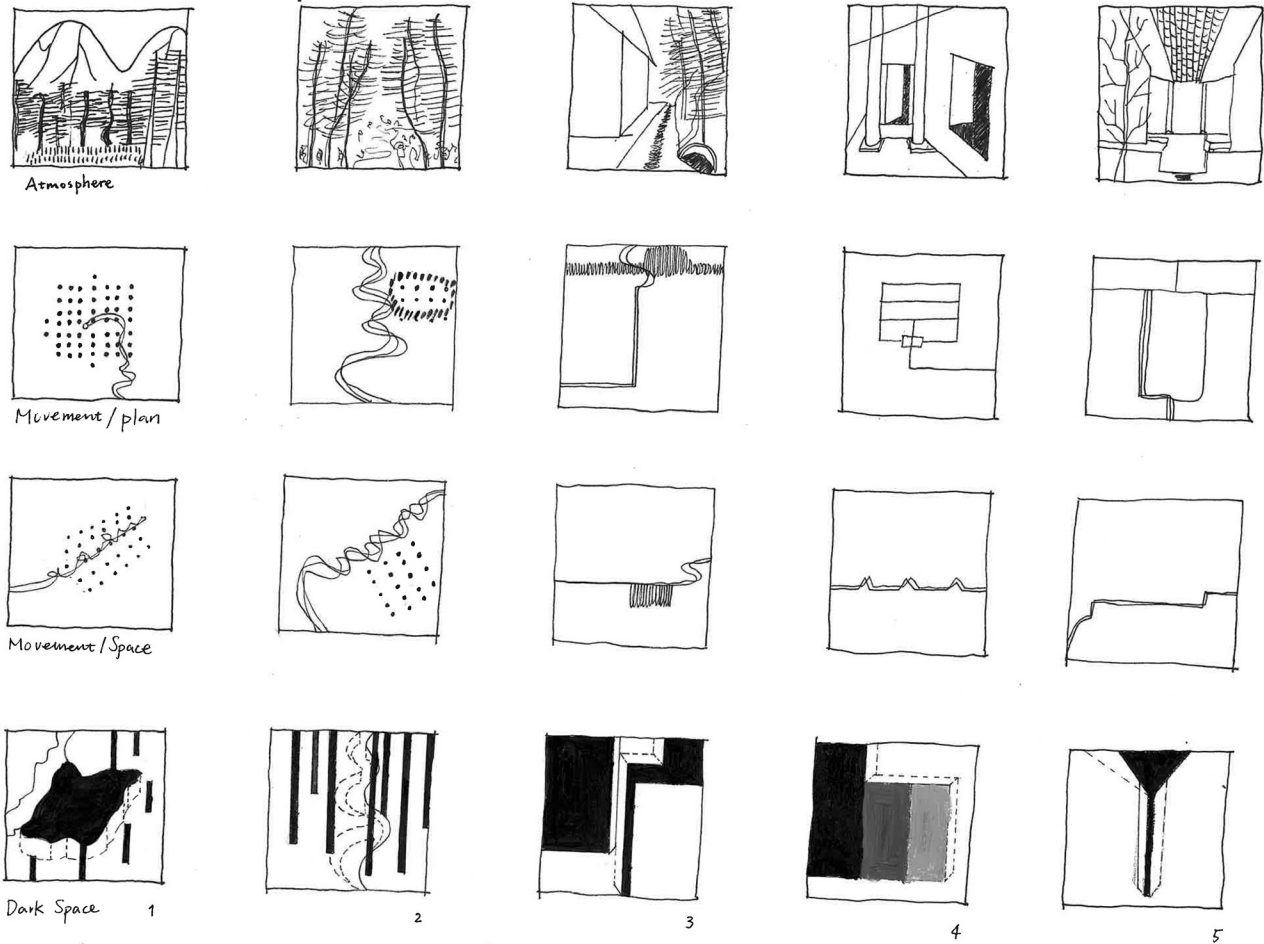

Measure  
Journey is very important

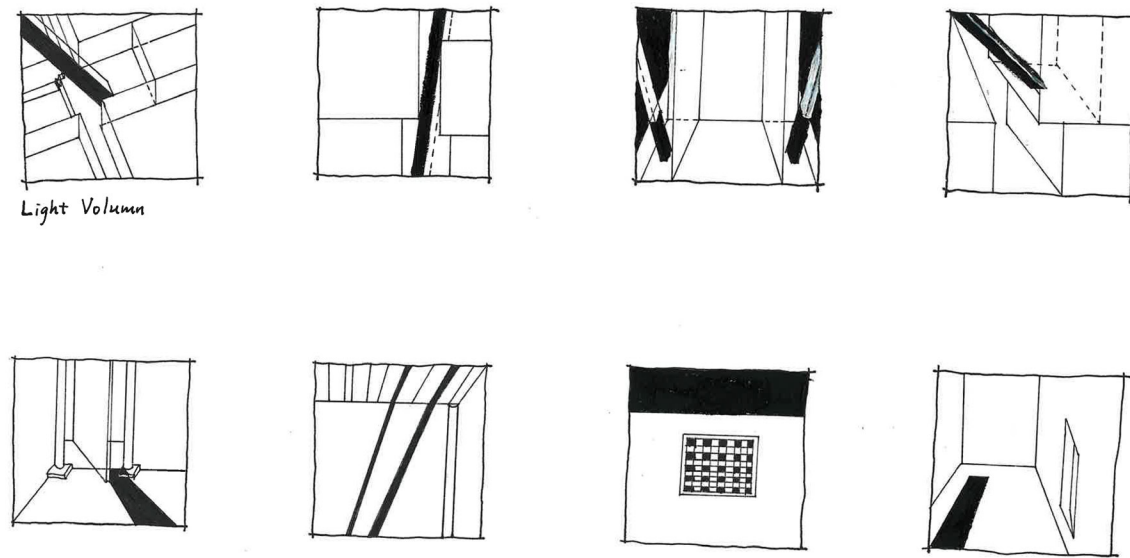

Being in the landscape

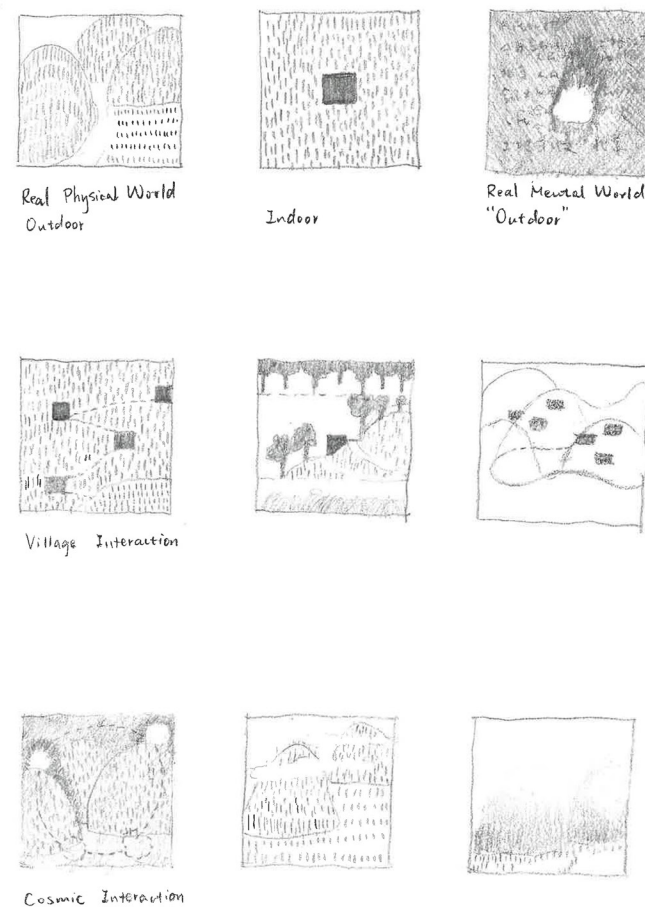



Sketches - Villopia

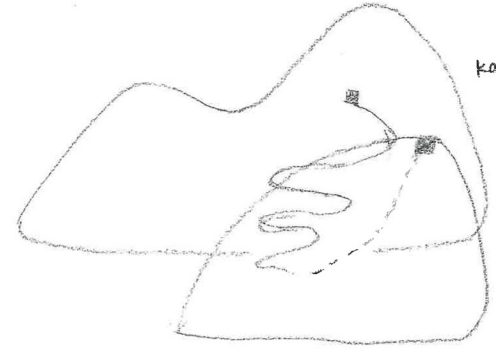
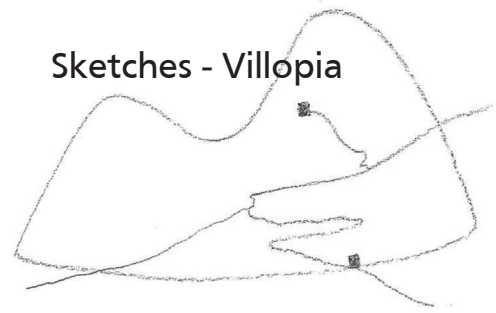

forest  
soil  
karst Rock

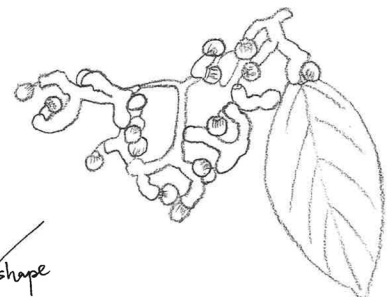
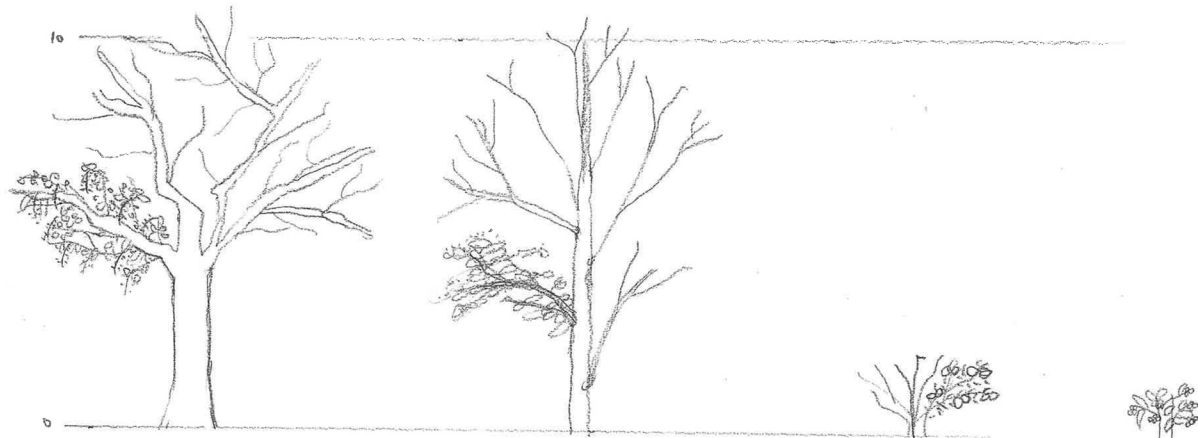
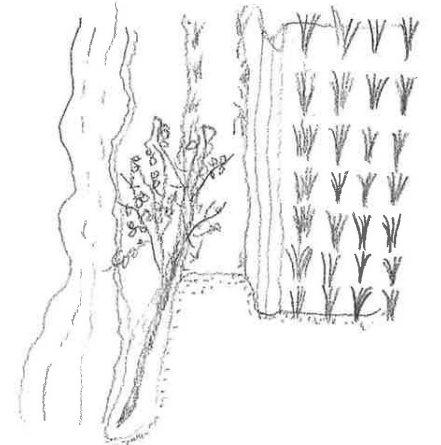
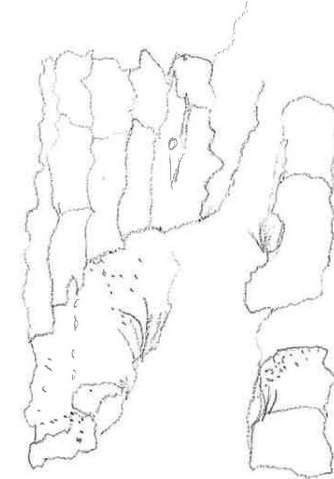
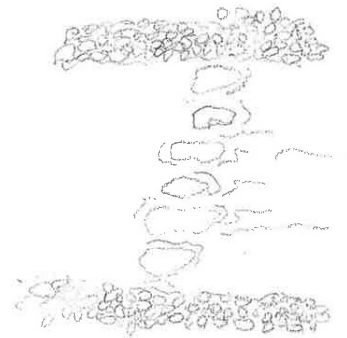
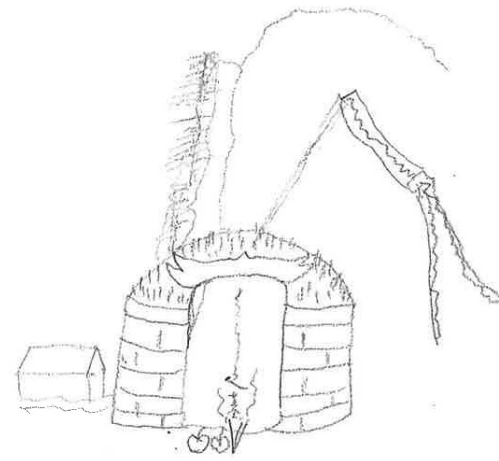
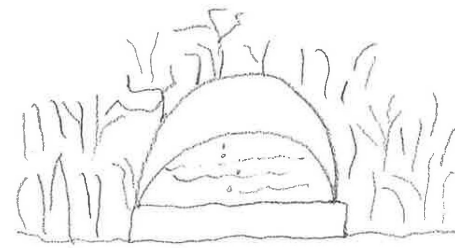
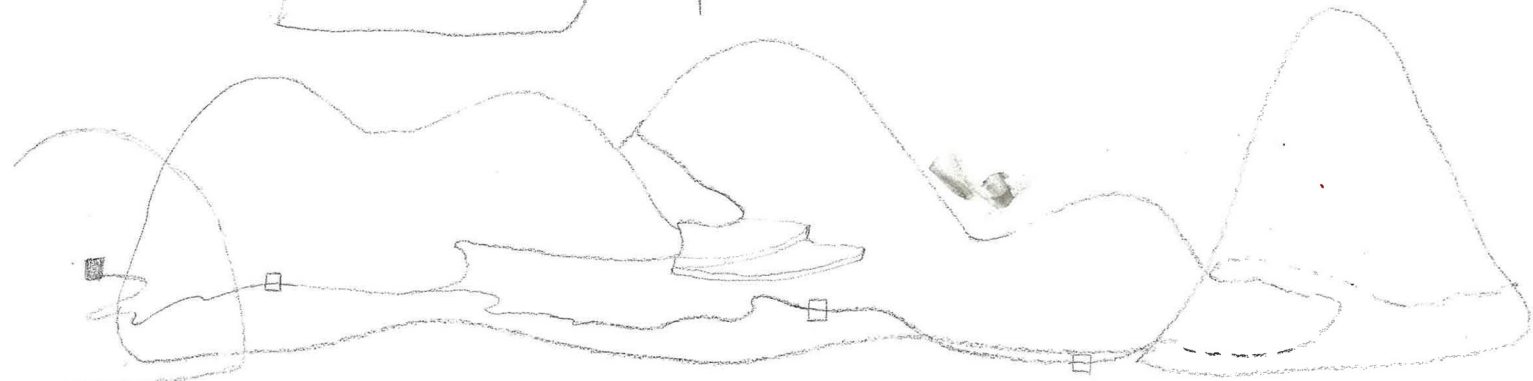
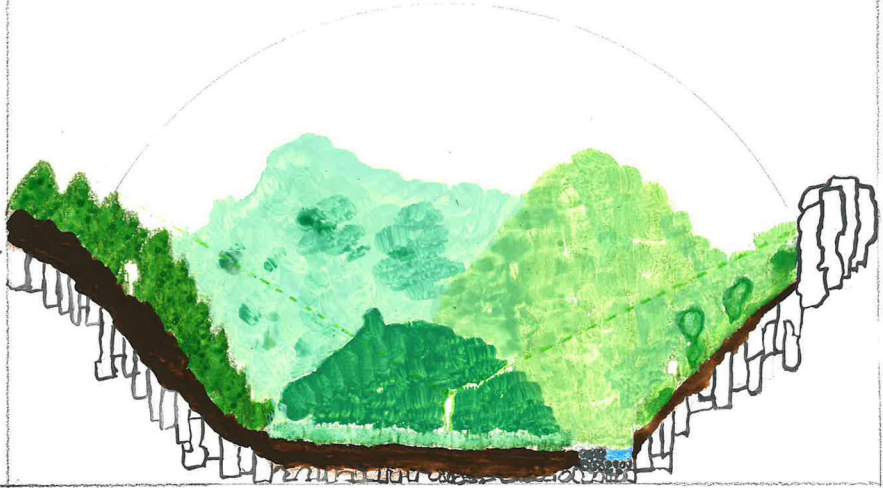

weird shape

Oct  
Hovenia Acerba  
Deciduous

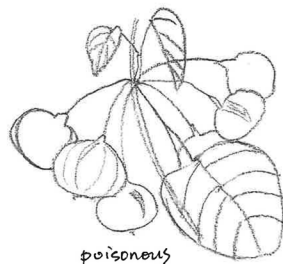

poisonous

Sep-Dec  
Tung oil Tree  
Deciduous

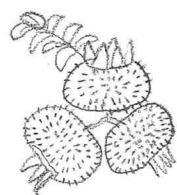

Aug-Sep  
Rosa Roxburghii  
shrub



Mar  
Rubus pentinellus  
shrub

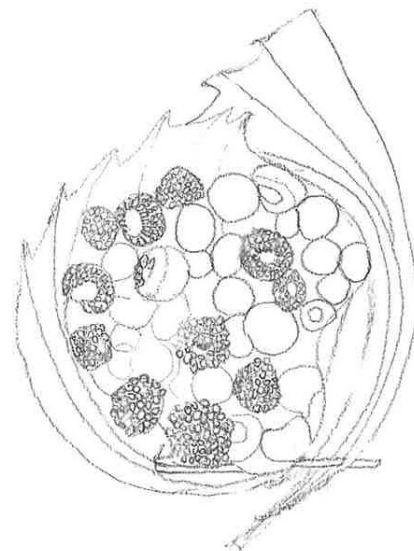

protective mode (easy to survive)





- |      |      |      |      |
|------|------|------|------|
| ① 木薯 | ② 木薯 | ③ 木薯 | ④ 木薯 |
| ⑤ 木薯 | ⑥ 木薯 | ⑦ 木薯 | ⑧ 木薯 |
| ⑨ 木薯 | ⑩ 木薯 | ⑪ 木薯 | ⑫ 木薯 |
| ⑬ 木薯 | ⑭ 木薯 | ⑮ 木薯 | ⑯ 木薯 |

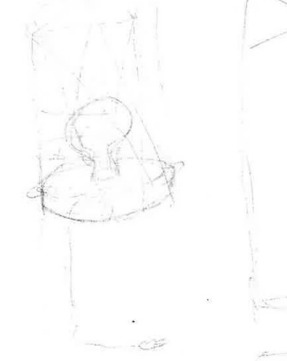
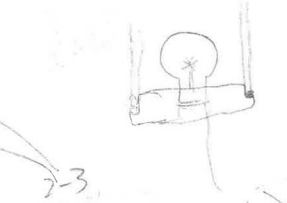
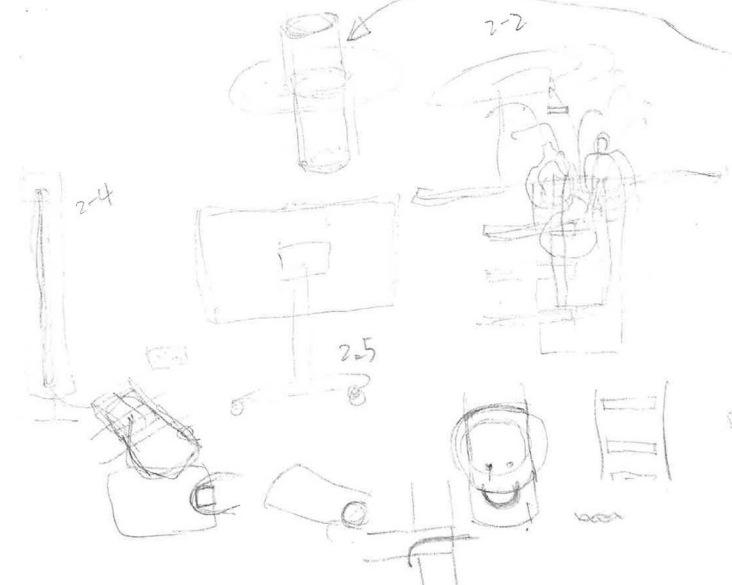
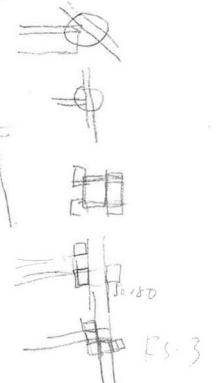
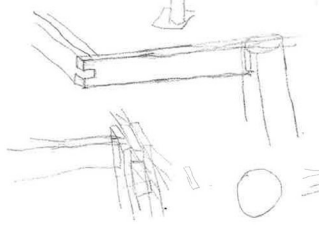
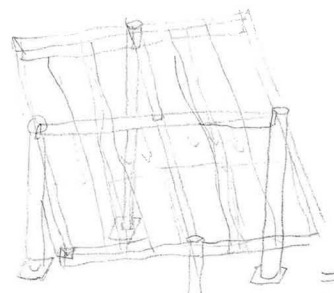
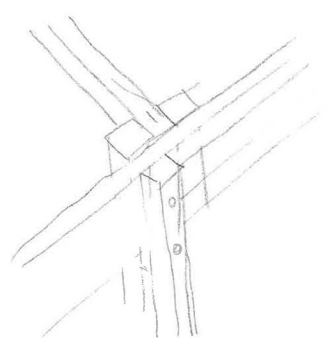
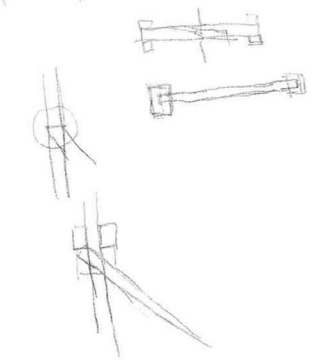
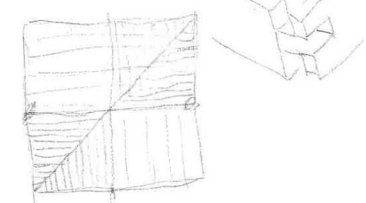
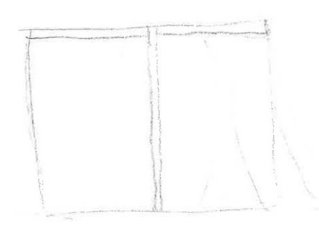
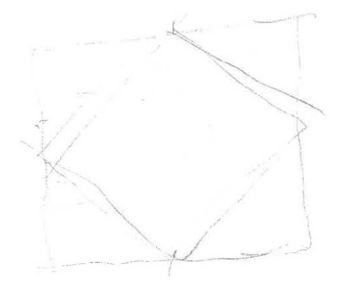
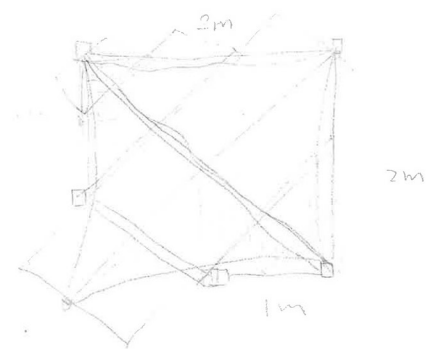
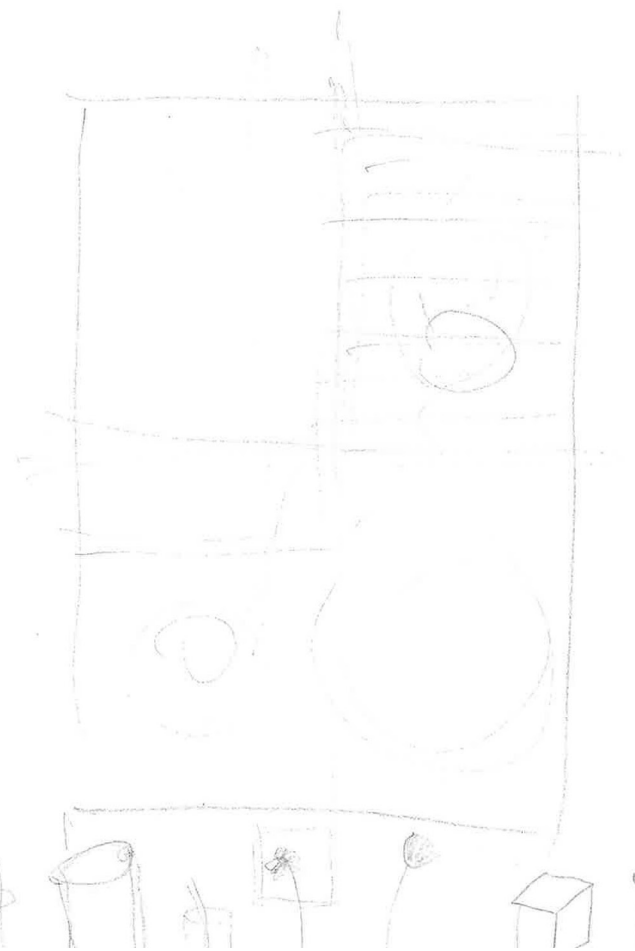
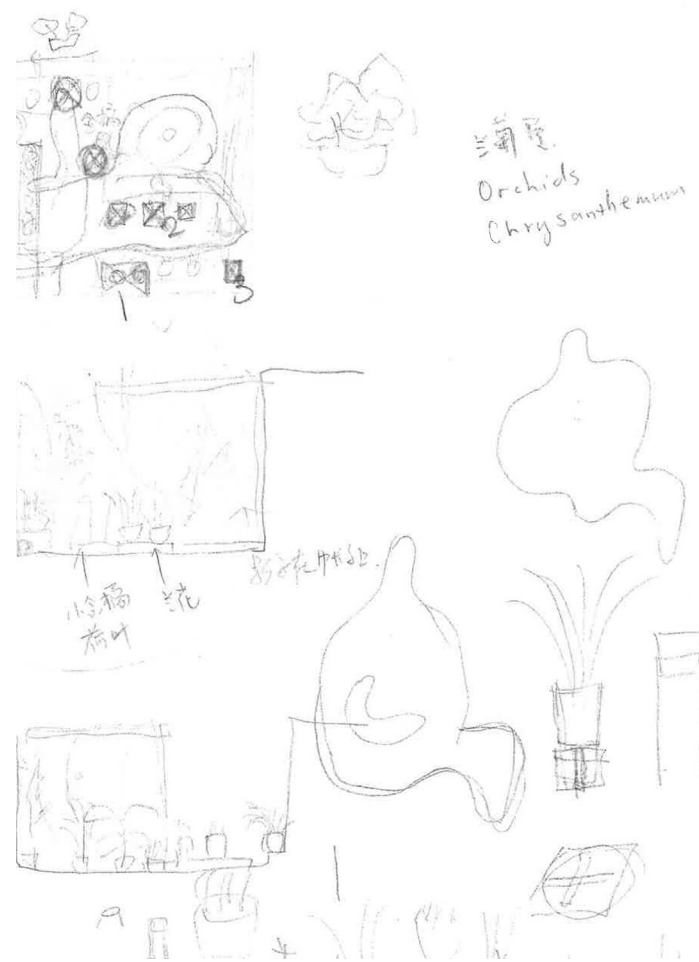



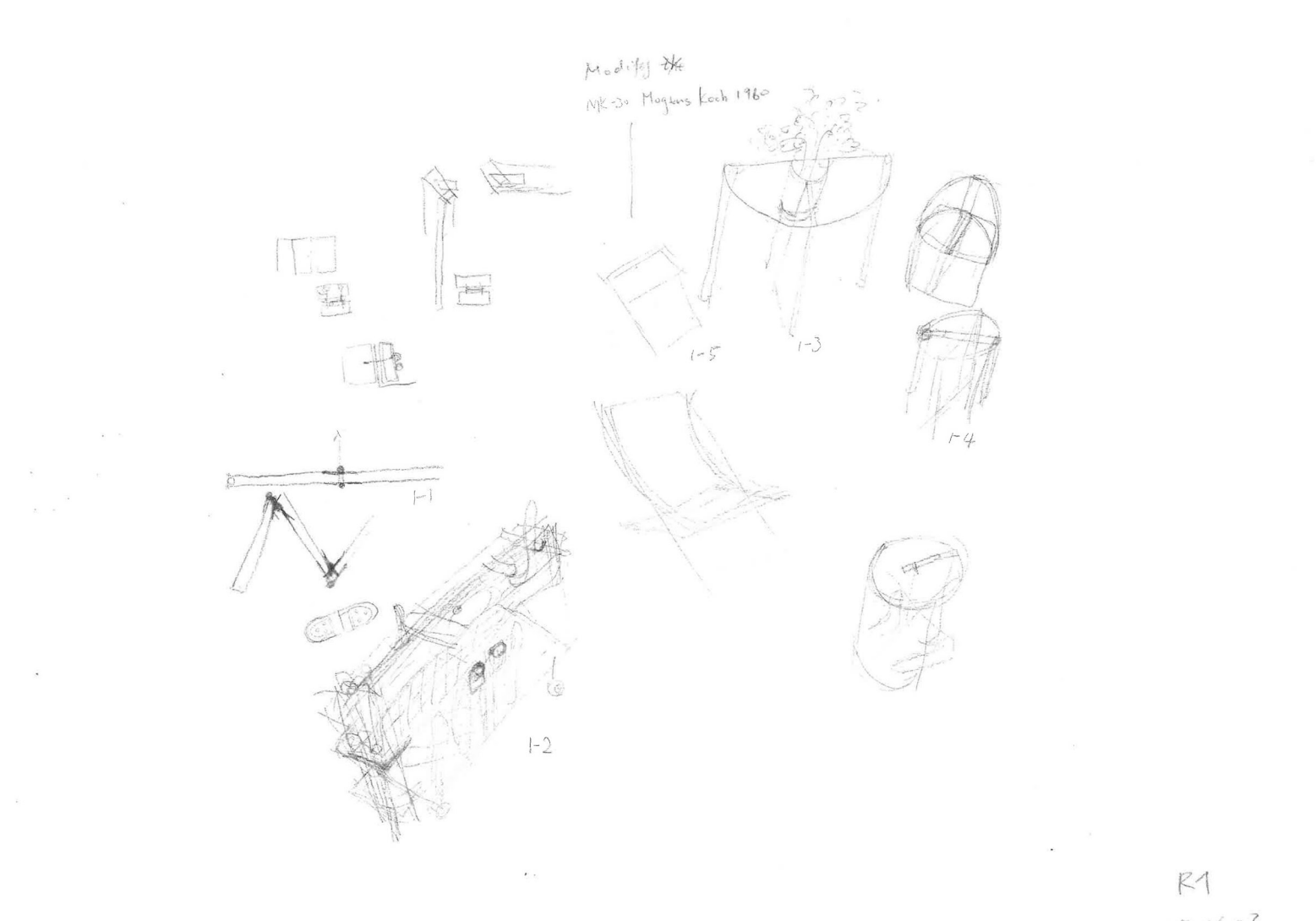
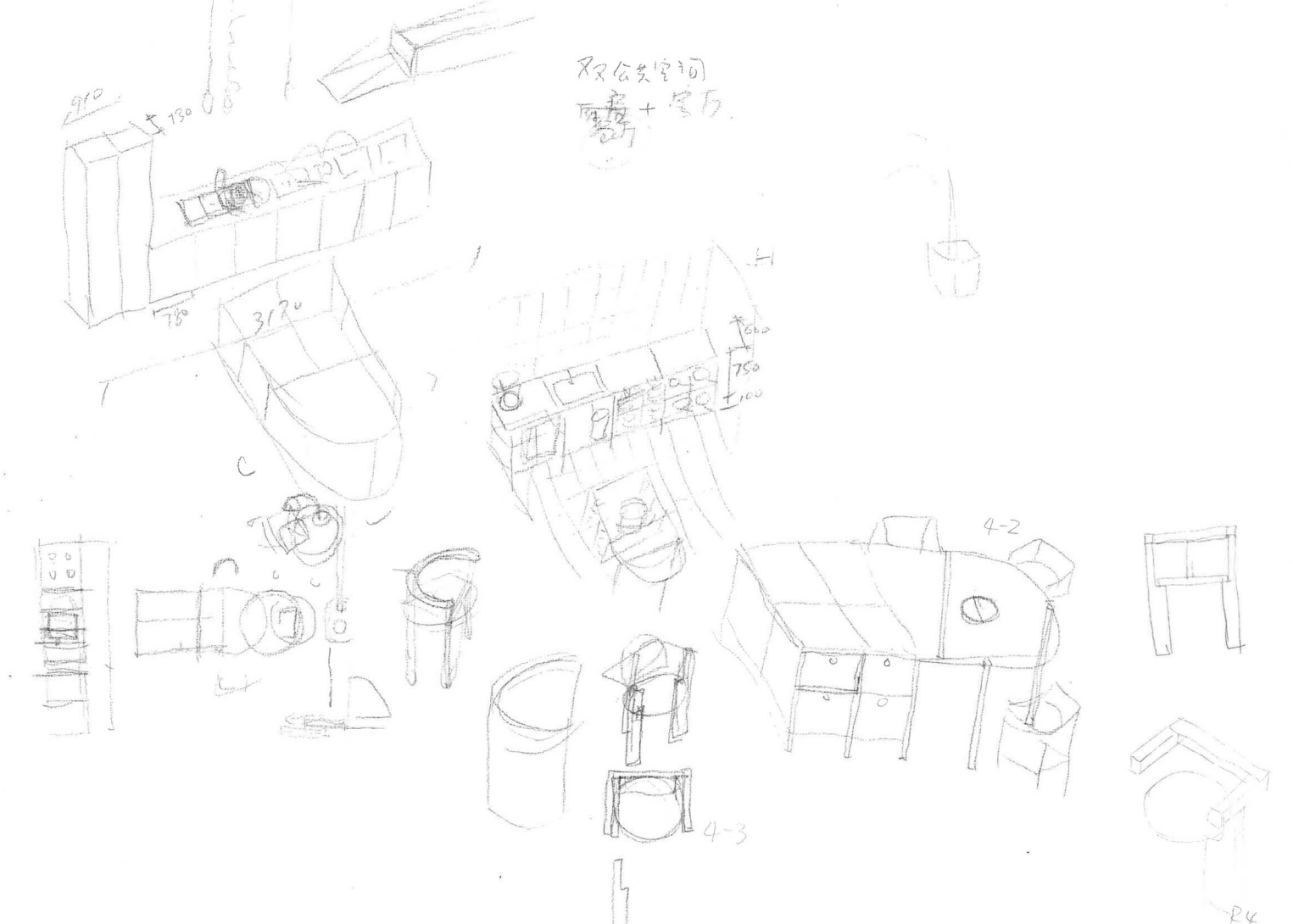
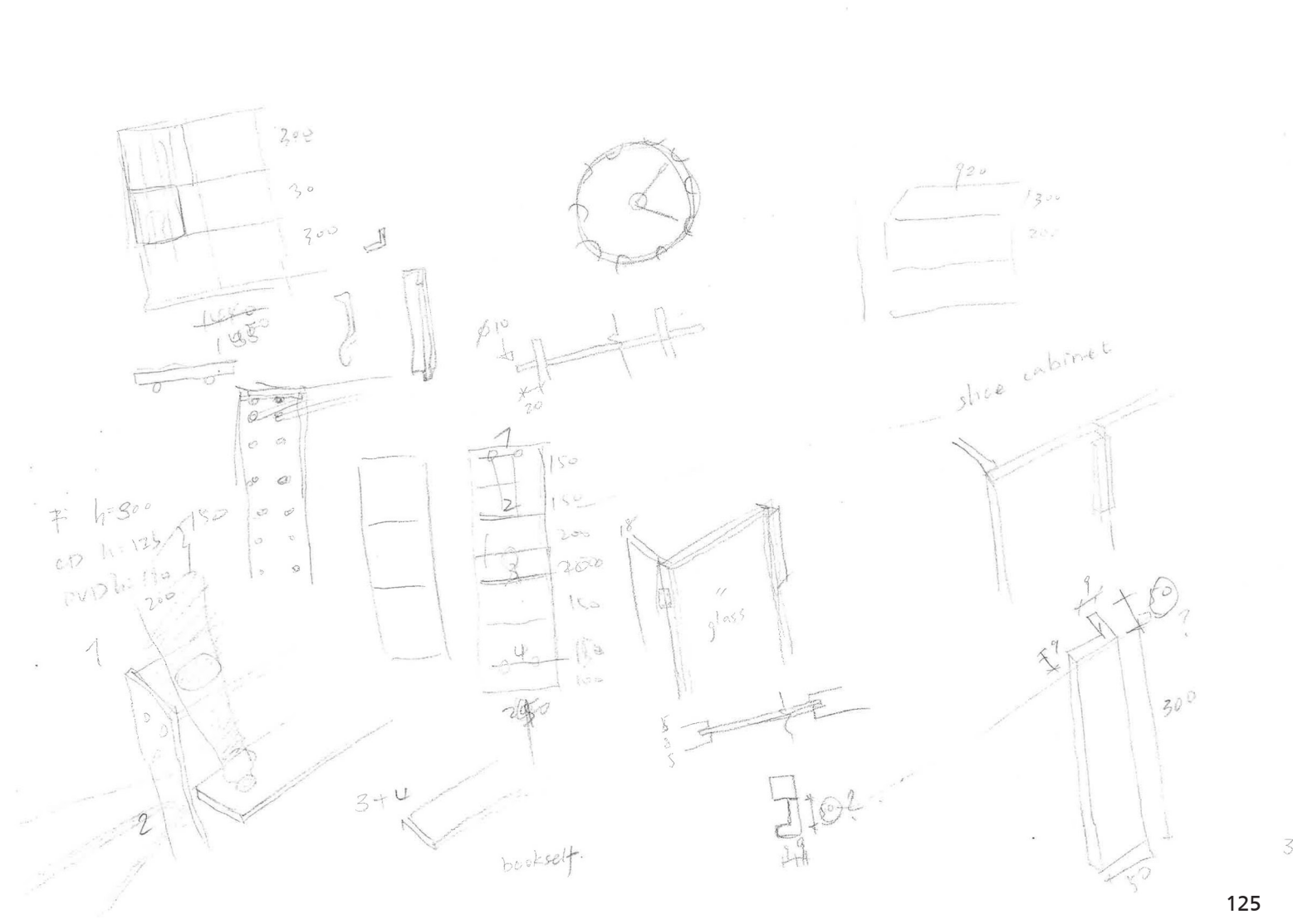
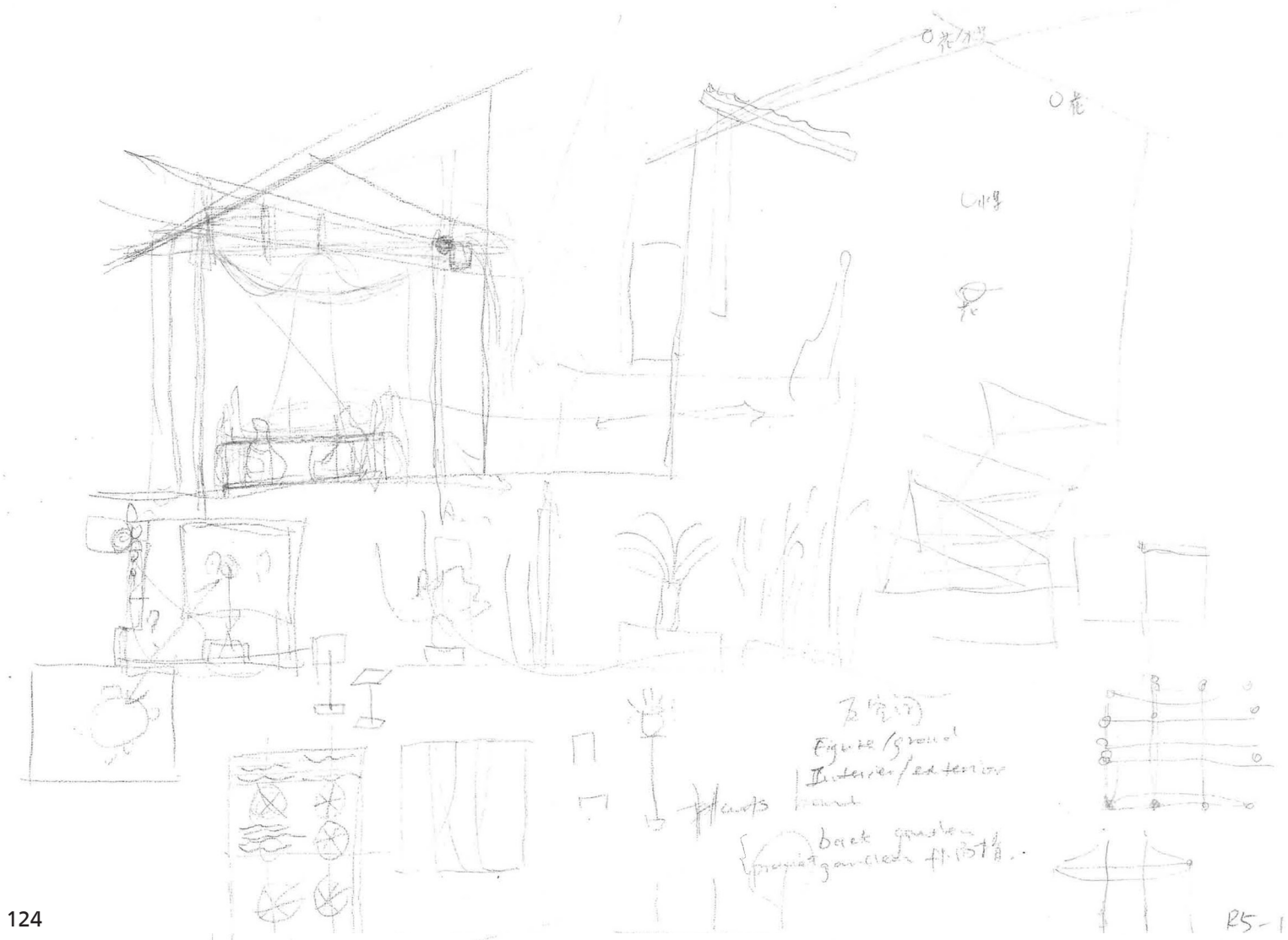







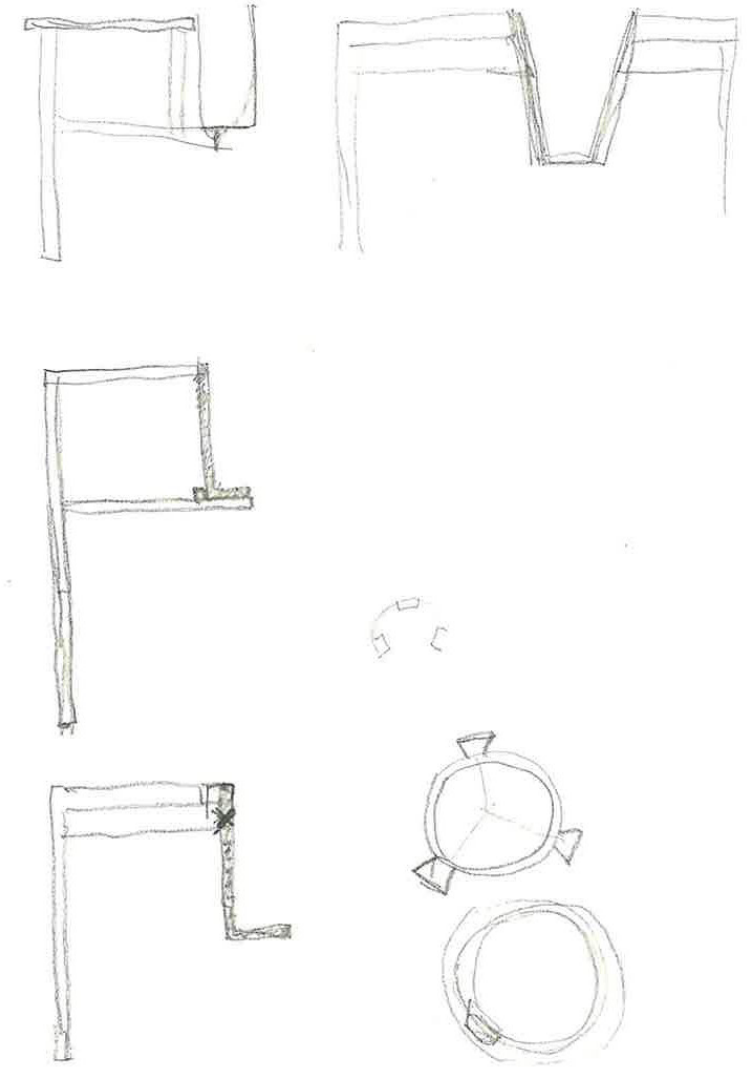
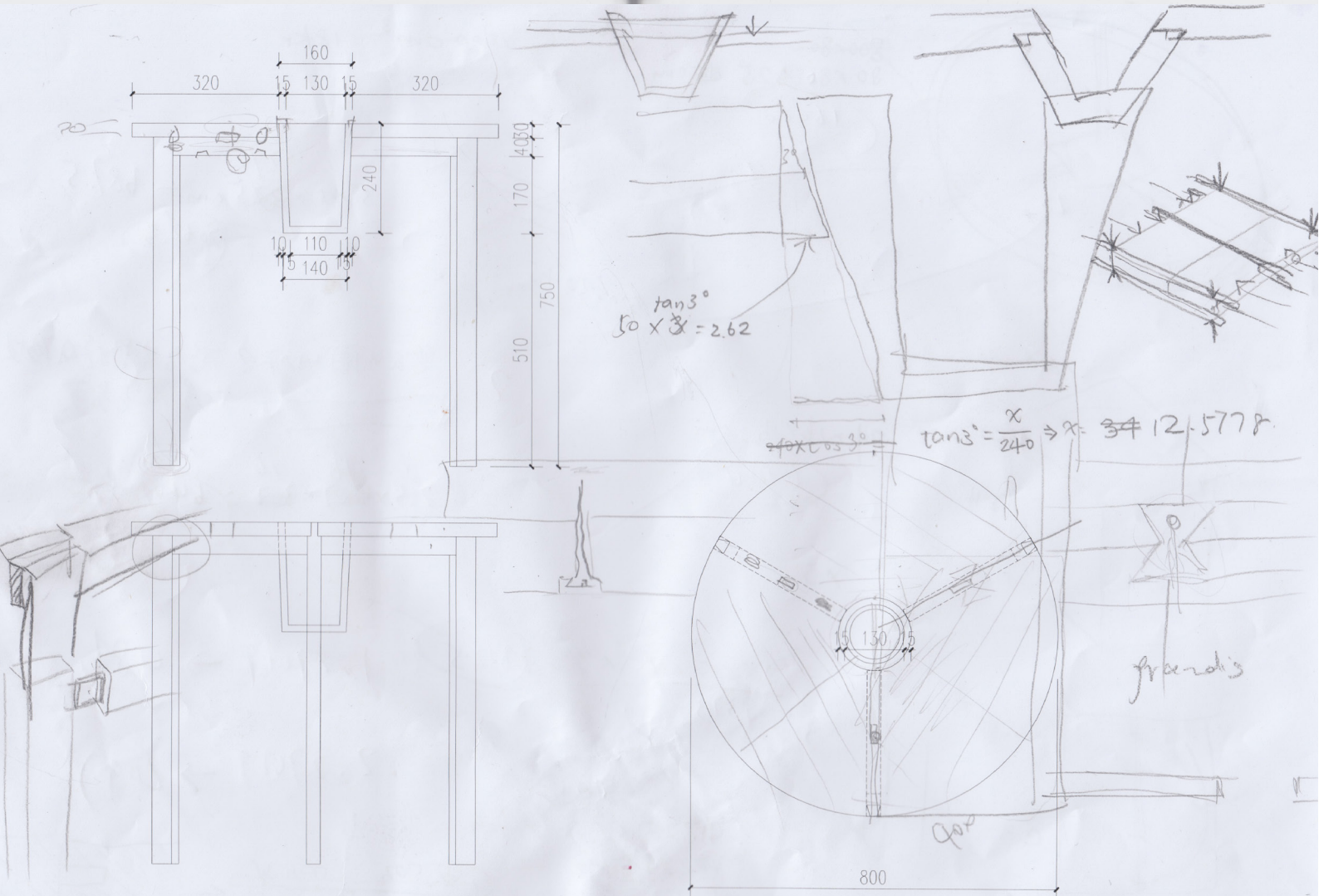
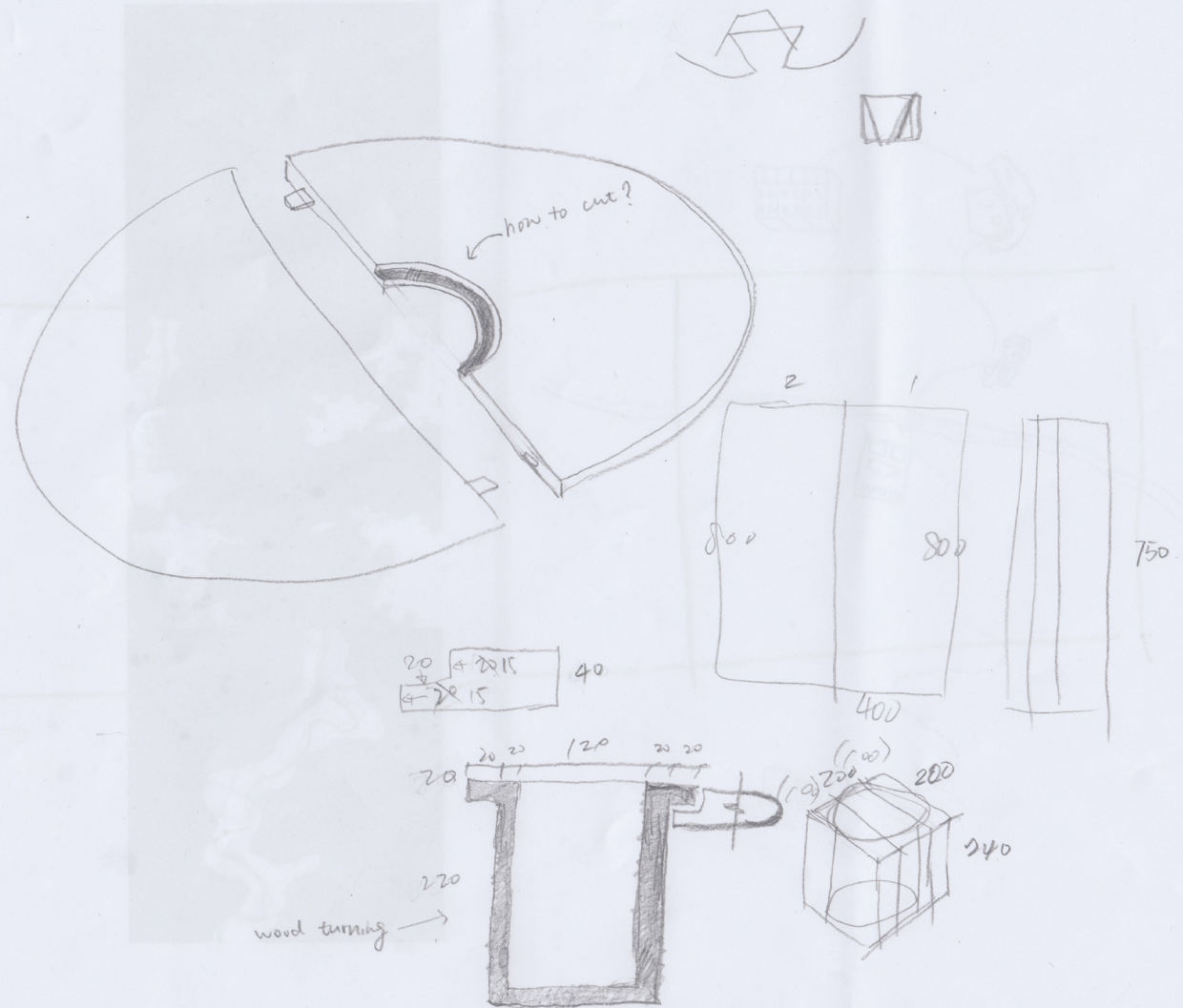

Do: 修改地图河与道路的颜色.

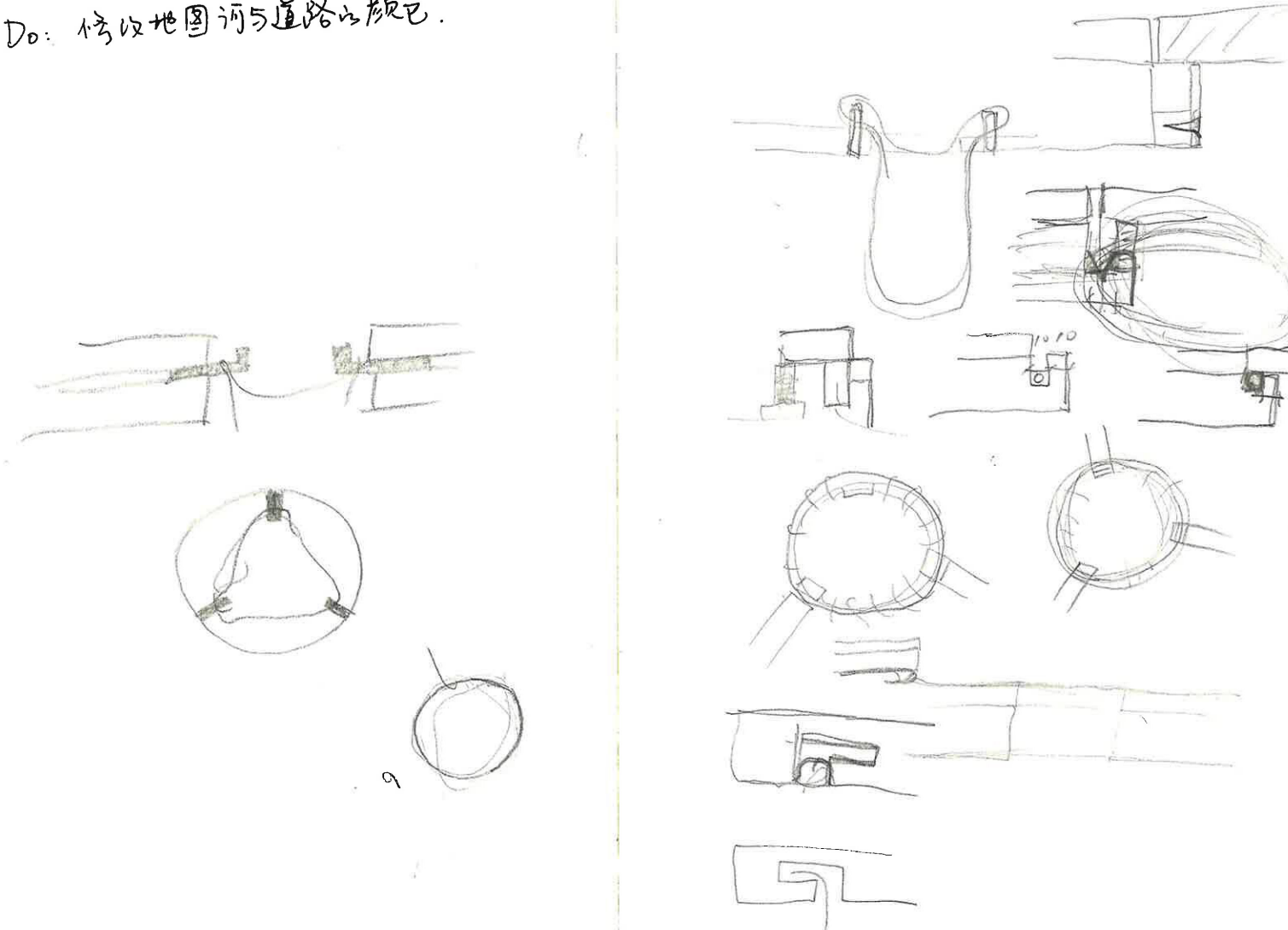





## The Black Space.

Place is made through time and space, and time cannot exist in the blackspace.

Is the blackspace (time- and) placeless?

Maybe it is placeless from the inside, the place around does not matter once you get in it (???)

1. If the content is universe, the blackspace is the black hole, then it is placeless from outside position.

Agree with this, but are there 3 situations =

1. It doesn't matter for people inside
2. What if there is another system or dimension of time, people inside find place again.
3. If they still have memory, is it form of time to make space? inside

2. If the content is facade or village, the space is human-sensed scale and time always exists in it, so there are always places.





# EXPRESSIONS AND INSPIRATIONS

Collage, 1979, Sigurdur Gudmundsson

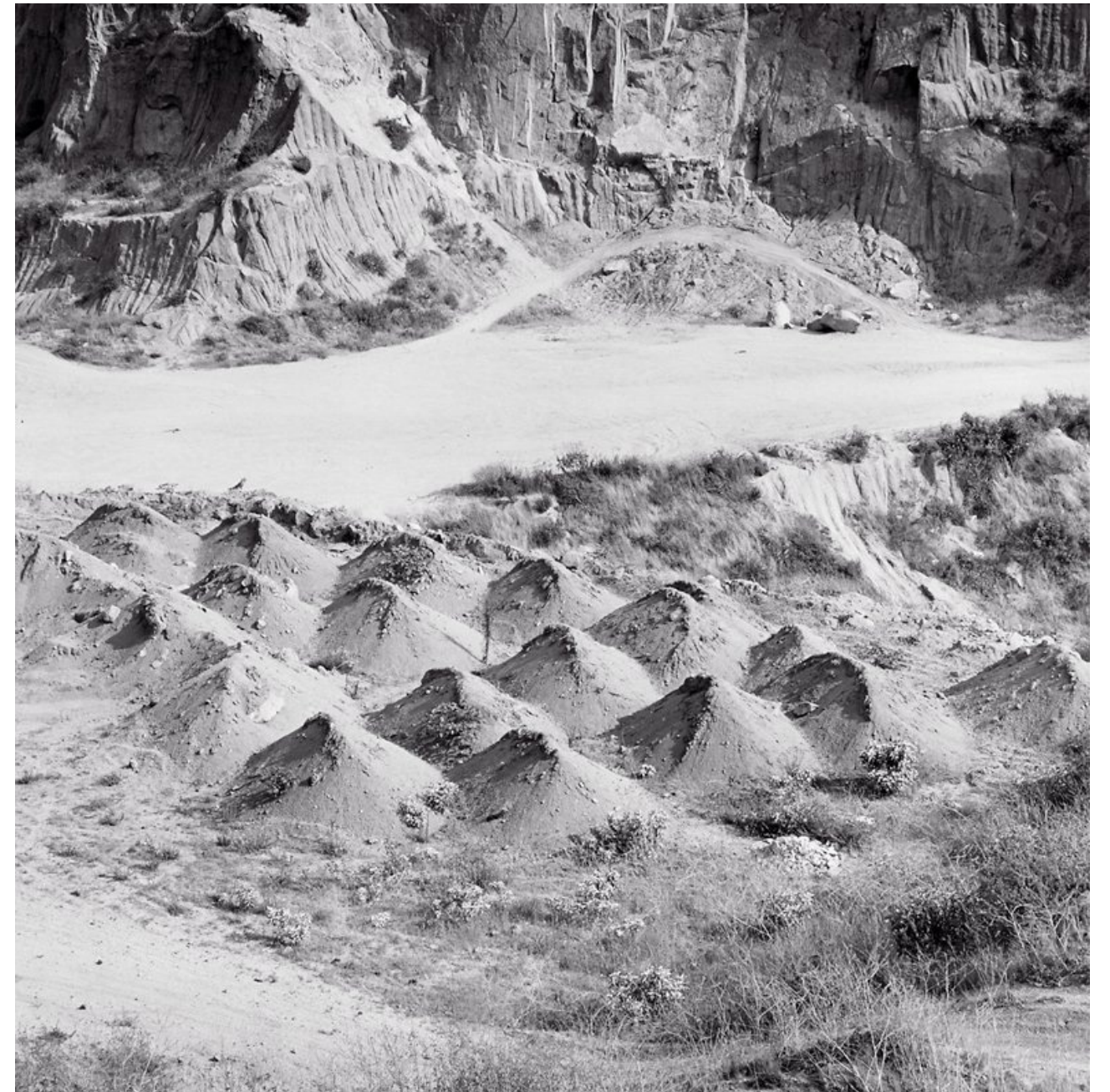





Untitled (Sulptural study, two-part construction), 1974 - 2013,  
Fred Sandback © Lisson Gallery



The yarn construction loses its egocentric perception, thus it is no longer "schematic" but "diagrammatic" as if a script for a spatial game of thought.

"The room has lost its partitions and releases an atom into the luminous void, an impersonal yet singular atom that no longer has a Self by which it might distinguish itself from or merge with others. Becoming imperceptible is Life, "without cessation or condition"... attaining to a cosmic and spiritual lapping."(The Greatest Irish Film, Gilles Deleuze)

John Rajchman, Fred Sandback's Lines of Thought









Forest, 1954, Ryūichi Yamashiro





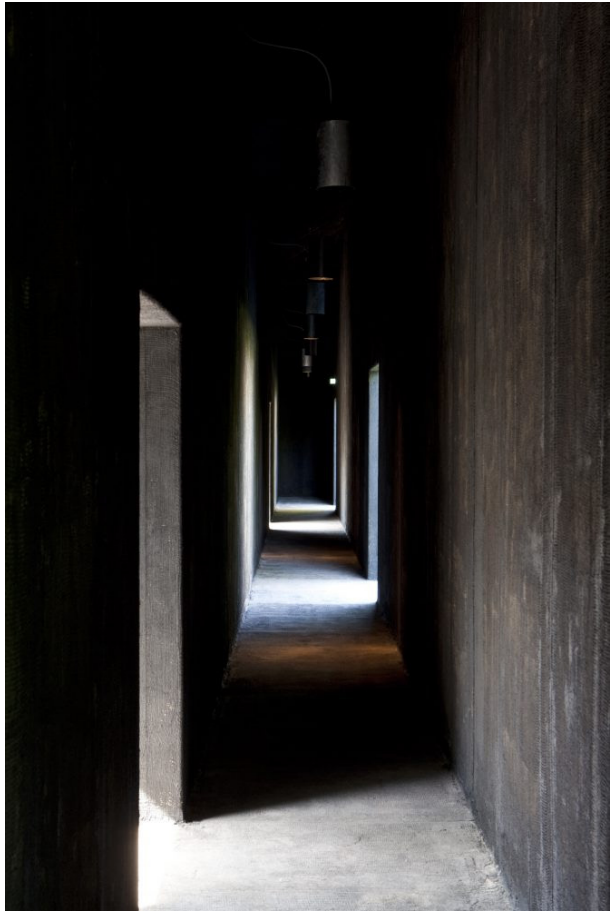

Serpentine Gallery Pavilion 2011, Peter Zumthor



Therme Vals, Peter Zumthor  
© Fernando Guerra





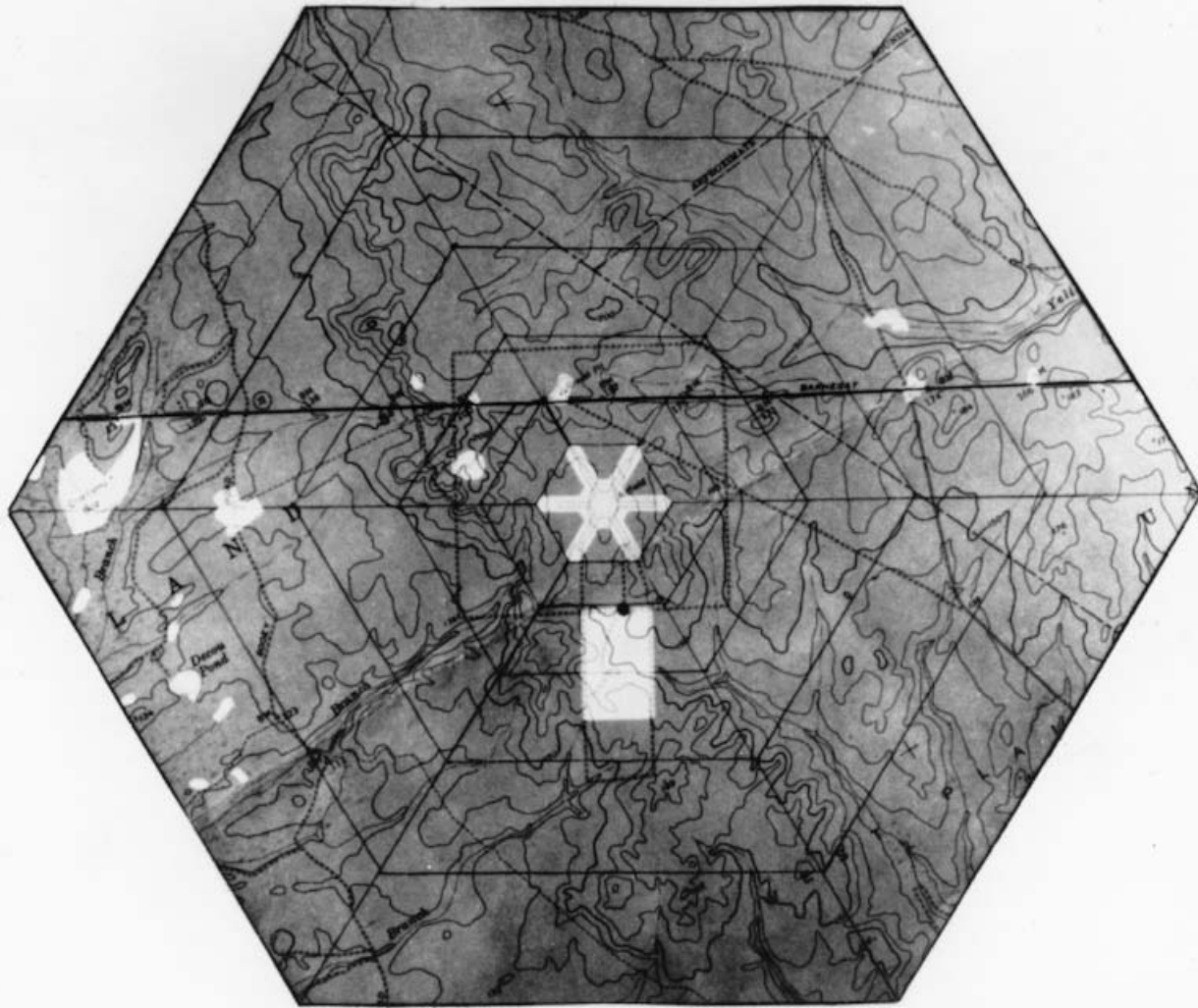

A NONSITE (an indoor earthwork)

31 sub-divisions based on a hexagonal "airfield" in the Woodmansie Quadrangle - new Jersey (Topographic) map. Each sub-division of the Nonsite contains sand from the site shown on the map. Tours between the Nonsite and the site are possible. The red dot on the map is the place where the sand was collected.

The Nonsite (an indoor earthwork) is a three dimensional logical picture that is abstract, yet it represents an actual site in N.J. (The Pine Barrens Plains)... Between the actual site in the Pine Barrens and The Nonsite itself exists a space of metaphoric significance. It could be that "travel" in this space is a vast metaphor. Everything between the two sites could become physical metaphorical material devoid of natural meanings and realistic assumptions. Let us say that one goes on a fictitious trip if one decides to go to the site of the Nonsite. The "trip" becomes invented, devised, artificial; therefore, one might call it a non- trip to a site from a Nonsite.

Smithson, Robert. "A Provisional Theory of Nonsites." In Robert Smithson: The Collected Writings, Jack Flam. University of California Press, 1996.

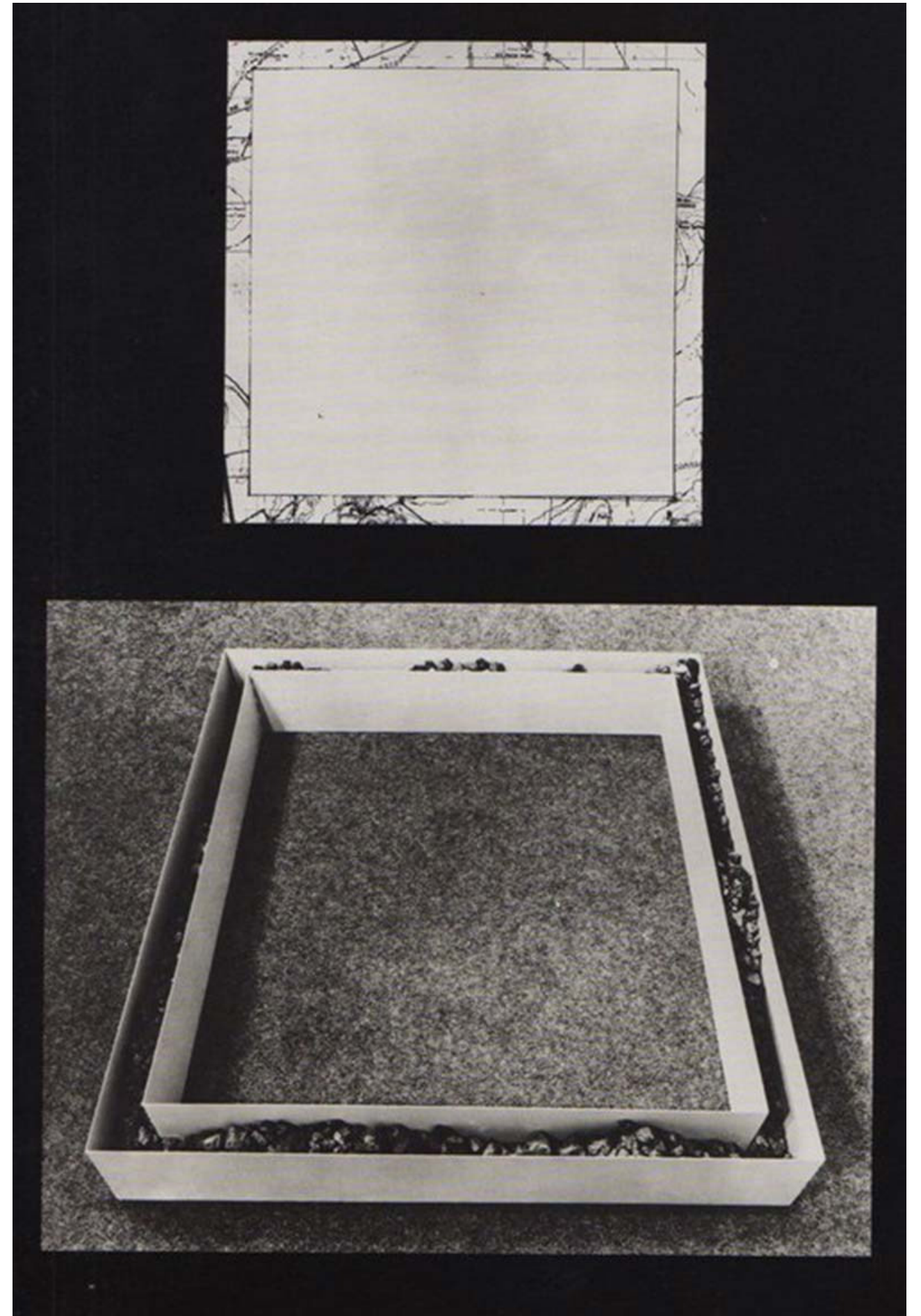





144

### Earthworks and Beyond

Revival Field collaborating with the scientist is a process that sculpts a site's ecology by using plants to absorb heavy metals from the toxic soil.

Revival Field, 1991-ongoing, Mel Chin  
© melchin.org

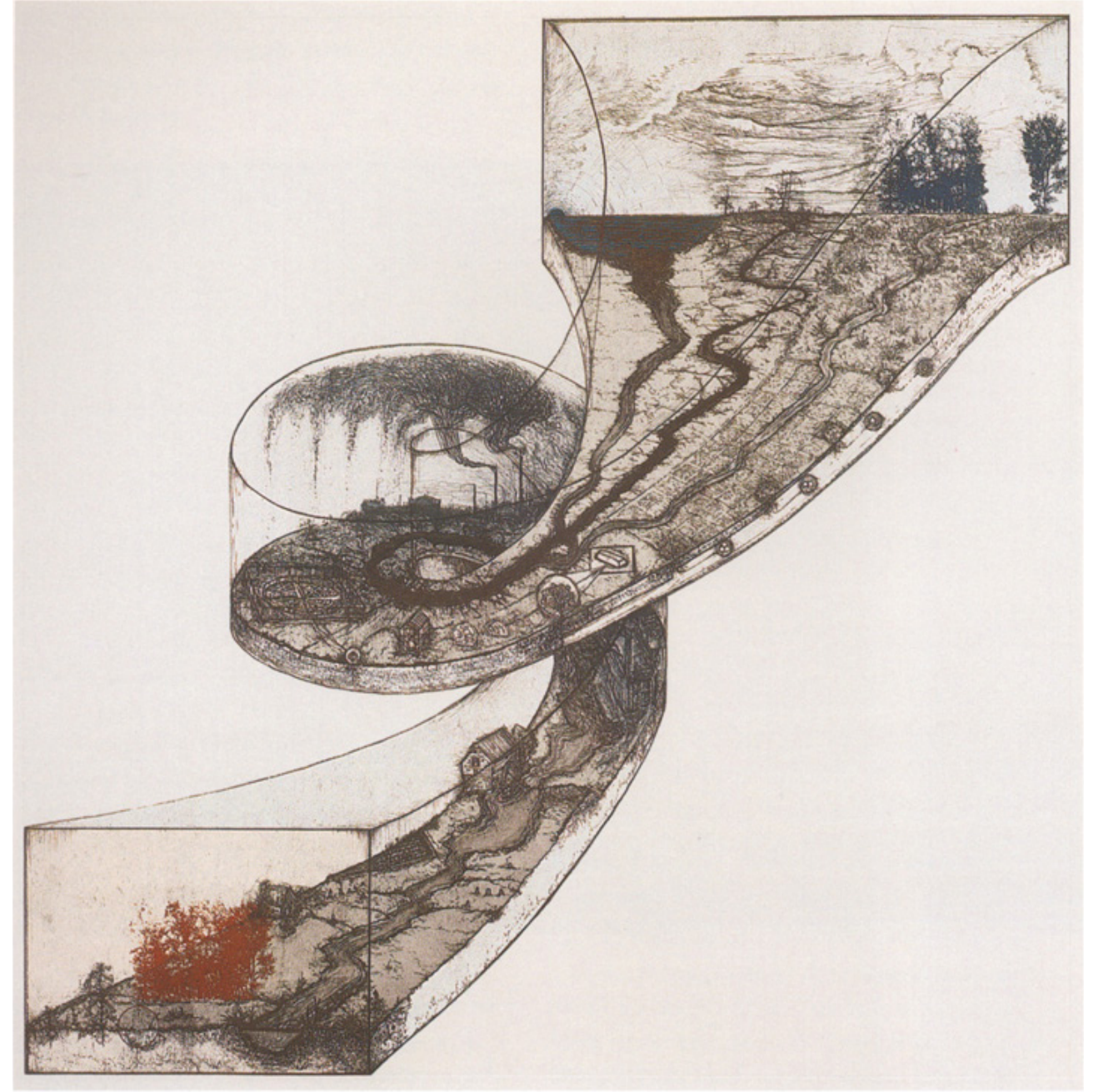

145

Revival Ramp, 1996, Mel Chin  
© melchin.org



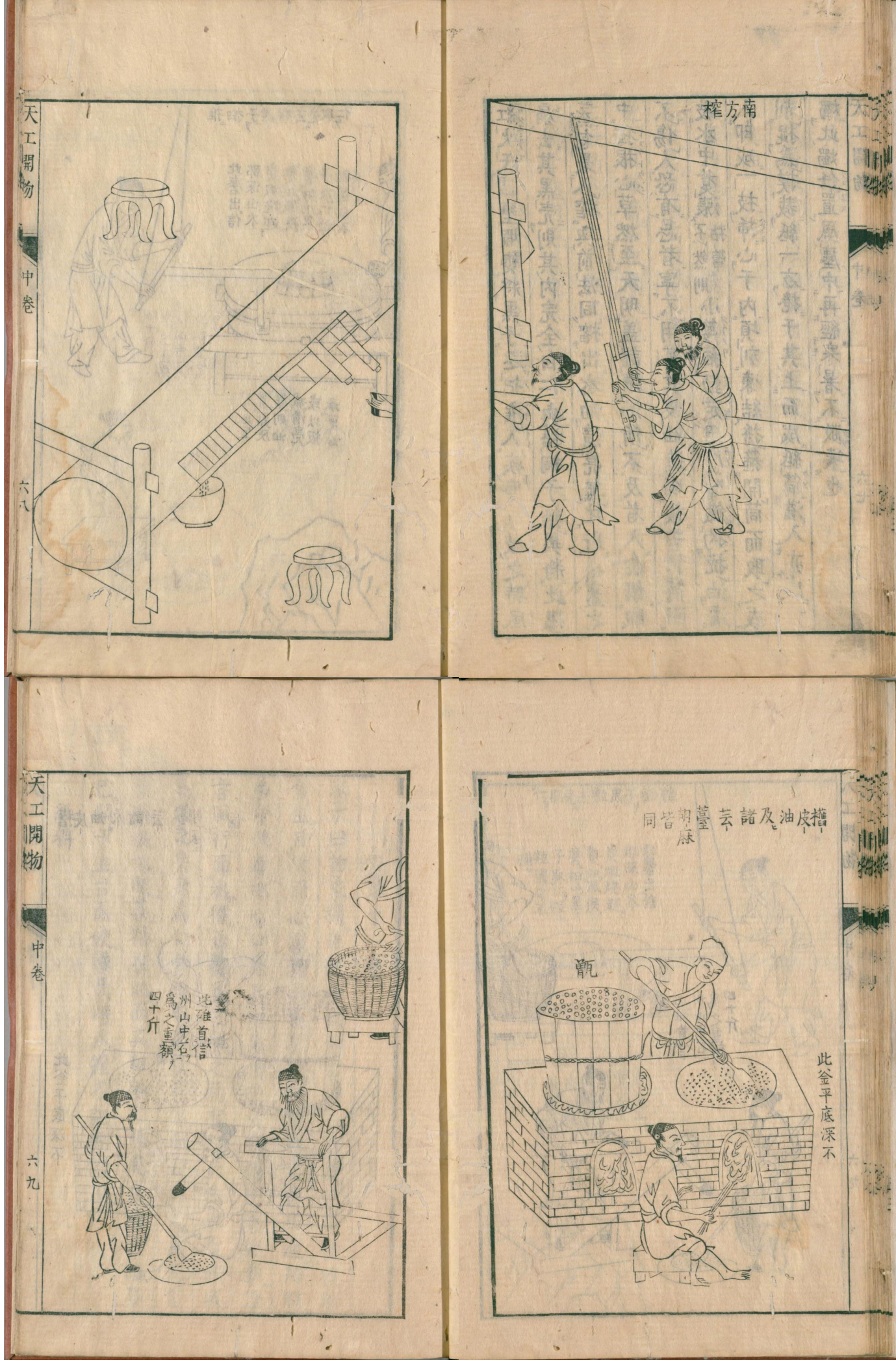













Running Fence, Sonoma and Marin Counties,  
California, 1972-76, Christo and Jeanne-Claude



Riverbed, 2014, Olafur Eliasson





Blackfield, 2022, Zadok Ben-David  
Ines Stuart-Davidson © RBG Kew



A drawing plan of the stone wall on which plants  
grow at "Valeria P. Cirell's Home." 1958  
© Instituto Lina Bo e P. M. Bardi. Image Courtesy  
of Fundació Joan Miró, Barcelona





The Penitent Magdalen, Georges de La Tour, 1640  
© The Metropolitan Museum of Art





Thanks for coming to Villopia!

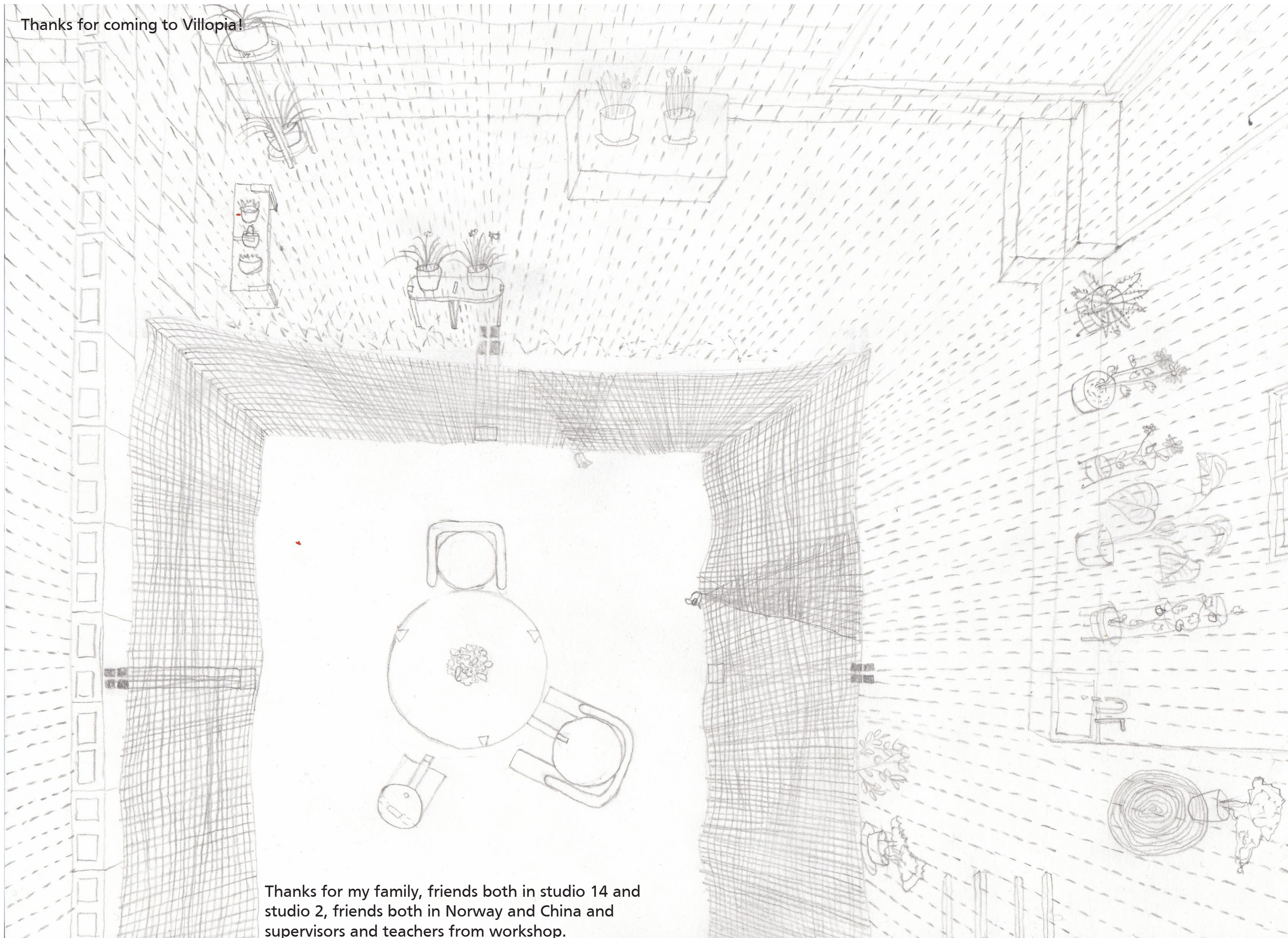

Thanks for my family, friends both in studio 14 and studio 2, friends both in Norway and China and supervisors and teachers from workshop.